

**brother**®

# BASIC USER'S GUIDE

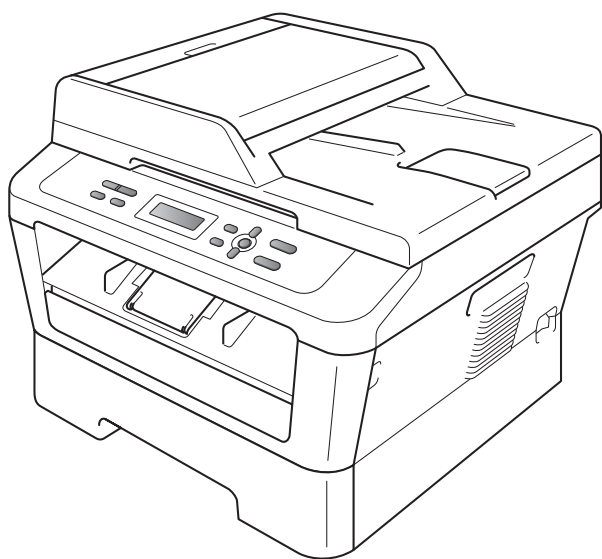

**DCP-7055**  
**DCP-7055W**  
**DCP-7057**  
**DCP-7057W**  
**DCP-7060D**  
**DCP-7065DN**  
**DCP-7070DW**

Not all models are available in all countries.

Version D

UK/IRE

## If you need to call Customer Service

Please complete the following information for future reference:

**Model Number:** DCP-7055 / DCP-7055W / DCP-7057 /  
DCP-7057W / DCP-7060D / DCP-7065DN /  
DCP-7070DW  
(Circle your model number)

**Serial Number:** <sup>1</sup> \_\_\_\_\_

**Date of Purchase:** \_\_\_\_\_

**Place of Purchase:** \_\_\_\_\_

<sup>1</sup> The serial number is on the back of the unit. Retain this User's Guide with your sales receipt as a permanent record of your purchase, in the event of theft, fire or warranty service.

Register your product on-line at

<http://www.brother.com/registration/>

# User's Guides and where do I find it?

Which manual?	What's in it?	Where is it?
<b>Safety and Legal</b>	Read this Guide first. Please read the Safety Instructions before you set up your machine. See this Guide for trademarks and legal limitations.	Printed / In the Box
<b>Quick Setup Guide</b>	Follow the instructions for setting up your machine and installing the drivers and software for the operating system and connection type you are using.	
<b>Basic User's Guide</b>	Learn the basic Copy and Scan operations and how to replace consumables. See troubleshooting tips.	PDF file / Documentation CD-ROM / In the Box
<b>Advanced User's Guide</b>	Learn more advanced operations: Copy, printing reports, and performing routine maintenance.	
<b>Software User's Guide</b>	Follow these instructions for Printing and Scanning. Instructions are included for Network Scanning (For DCP-7055W / DCP-7057W / DCP-7065DN / DCP-7070DW) and using the Brother ControlCenter utility.	
<b>Network Glossary</b> (For DCP-7055W / DCP-7057W / DCP-7065DN / DCP-7070DW)	This Guide provides basic information about advanced network features of Brother machines along with explanations about general networking and common terms.	
<b>Network User's Guide</b> (For DCP-7055W / DCP-7057W / DCP-7065DN / DCP-7070DW)	This Guide provides useful information about wired and wireless network settings and security settings using the Brother machine. You can also find supported protocol information for your machine and detailed troubleshooting tips.	

# Table of Contents

## (BASIC USER'S GUIDE)

<b>1</b>	<b>General information</b>	<b>1</b>
	Using the documentation .....	1
	Symbols and conventions used in the documentation .....	1
	Accessing the Advanced User's Guide, Software User's Guide and Network User's Guide.....	2
	Viewing Documentation.....	2
	Accessing Brother Support (Windows®) .....	4
	Accessing Brother Support (Macintosh) .....	5
	Control panel overview .....	6
	Changing LCD language .....	8
<b>2</b>	<b>Loading paper</b>	<b>9</b>
	Loading paper and print media .....	9
	Loading paper in the standard paper tray.....	9
	Loading paper in the manual feed slot .....	11
	Unscannable and unprintable areas .....	15
	Paper settings.....	16
	Paper Type .....	16
	Paper Size .....	16
	Acceptable paper and other print media .....	17
	Recommended paper and print media .....	17
	Type and size of paper .....	17
	Handling and using special paper .....	18
<b>3</b>	<b>Loading documents</b>	<b>21</b>
	How to load documents .....	21
	Using the automatic document feeder (ADF) (For DCP-7065DN).....	21
	Using the scanner glass .....	22
<b>4</b>	<b>Making copies</b>	<b>24</b>
	How to copy .....	24
	Stop copying .....	24
	Copy settings.....	24
<b>5</b>	<b>How to print from a computer</b>	<b>25</b>
	Printing a document.....	25
<b>6</b>	<b>How to scan to a computer</b>	<b>26</b>
	Scanning a document as PDF file using ControlCenter4 (Windows®) .....	26
	Changing the SCAN key settings .....	29
	Before scanning.....	29
	SCAN key settings.....	29
	Scanning using the SCAN key .....	31



<b>A</b>	<b>Routine maintenance</b>	<b>32</b>
	Replacing the consumable items.....	32
	Replacing the toner cartridge .....	33
	Replacing the drum unit.....	39
	Cleaning the machine .....	44
	Cleaning the outside of the machine .....	44
	Cleaning the scanner glass .....	45
	Cleaning the corona wire .....	46
	Cleaning the drum unit .....	48
	Cleaning the paper pick-up rollers.....	52
<b>B</b>	<b>Troubleshooting</b>	<b>54</b>
	Error and maintenance messages.....	54
	Document Jams.....	57
	Document is jammed in the top of the ADF unit (For DCP-7065DN) .....	57
	Document is jammed under the document cover (For DCP-7065DN) .....	57
	Removing small documents jammed in the ADF (For DCP-7065DN).....	58
	Document is jammed at the output tray (For DCP-7065DN) .....	58
	Paper Jams.....	59
	Paper is jammed in the standard paper tray.....	59
	Paper is jammed at the back of the machine .....	60
	Paper is jammed inside the machine.....	62
	Paper is jammed in the Duplex Tray .....	66
	If you are having difficulty with your machine .....	68
	Improving the print quality.....	73
	Machine Information .....	83
	Checking the Serial Number.....	83
	Reset functions.....	83
	How to reset the machine.....	83
<b>C</b>	<b>Menu and features</b>	<b>84</b>
	On-screen programming.....	84
	Menu table.....	84
	How to access the menu mode .....	84
	Menu keys .....	85
	Menu table .....	86

---

**D Specifications 98**

---

General .....98  
Document Size ..... 101  
Print media..... 102  
Copy ..... 103  
Scanner ..... 104  
Printer ..... 105  
Interfaces ..... 106  
Computer requirements ..... 107  
Consumable items ..... 109  
Network (DCP-7055W / DCP-7057W / DCP-7065DN / DCP-7070DW) ..... 110

**E Index 111**

---

# Table of Contents

## (ADVANCED USER'S GUIDE)

The Advanced User's Guide explains the following features and operations. You can view the Advanced User's Guide on the Documentation CD-ROM.

### **1 General Setup**

---

*Memory Storage*  
*Ecology features*  
*Toner Settings*  
*LCD Contrast*  
*User Settings Report*  
*Network Configuration Report (For*  
*DCP-7055W / DCP-7057W /*  
*DCP-7065DN / DCP-7070DW)*  
*WLAN Report (For DCP-7055W /*  
*DCP-7057W / DCP-7070DW)*  
*Scanning using a scanner driver*

### **2 Making copies**

---

*Copy settings*  
*Duplex Copying*  
*(1-sided to 2-sided) (For DCP-7060D /*  
*DCP-7065DN / DCP-7070DW)*

### **A Routine maintenance**

---

*Cleaning the machine*  
*Checking the machine*  
*Packing and shipping the machine*

### **B Glossary**

---

### **C Index**

---

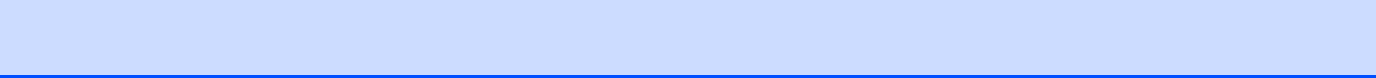

## Using the documentation

Thank you for buying a Brother machine! Reading the documentation will help you make the most of your machine.

## Symbols and conventions used in the documentation

The following symbols and conventions are used throughout the documentation.

<b>Bold</b>	Bold style identifies keys on the machine control panel or computer screen.
<i>Italics</i>	Italicized style emphasizes an important point or refers you to a related topic.
Courier New	Courier New font identifies the messages shown on the LCD of the machine.

## WARNING

WARNING indicates a potentially hazardous situation which, if not avoided, could result in death or serious injuries.

## CAUTION

CAUTION indicates a potentially hazardous situation which, if not avoided, may result in minor or moderate injuries.

## IMPORTANT

IMPORTANT indicates a potentially hazardous situation which, if not avoided, may result in damage to property or loss of product function.



Electrical Hazard icons alert you to a possible electrical shock.



Hot Surface icons warn you not to touch machine parts that are hot.



Notes tell you how you should respond to a situation that may arise or give tips about how the current operation works with other features.

# Accessing the Advanced User's Guide, Software User's Guide and Network User's Guide

This Basic User's Guide does not contain all the information about the machine such as how to use the advanced features Copy, Printer, Scanner and Network (for DCP-7055W / DCP-7057W / DCP-7065DN / DCP-7070DW). When you are ready to learn detailed information about these operations, read the **Advanced User's Guide**, **Software User's Guide**, **Network Glossary**, and **Network User's Guide** (for DCP-7055W / DCP-7057W / DCP-7065DN / DCP-7070DW) that are on the Documentation CD-ROM.

## Viewing Documentation

- 1 Turn on your computer. Insert the Documentation CD-ROM into your CD-ROM drive.



**Note**  
(Windows® users) If the screen does not appear automatically, go to **My Computer (Computer)**, double-click the CD-ROM icon, and then double-click **index.html**.

- 2 (Macintosh users) Double-click the Documentation CD-ROM icon, and then double-click **index.html**.

- 3 Click your country.

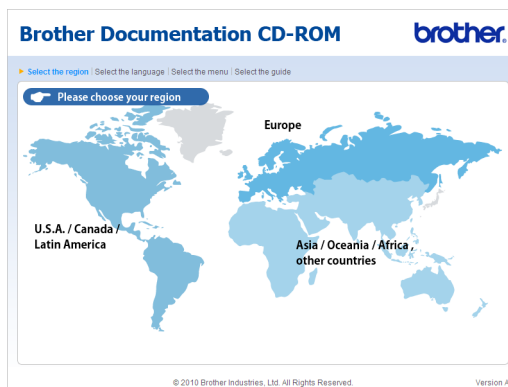

- 4 Point to your language, point to **View Guide**, and then click the guide you want to read.

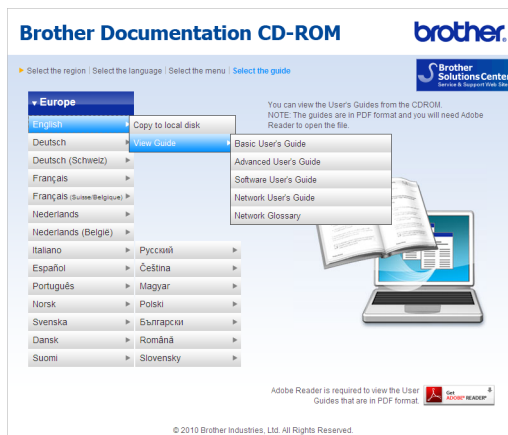
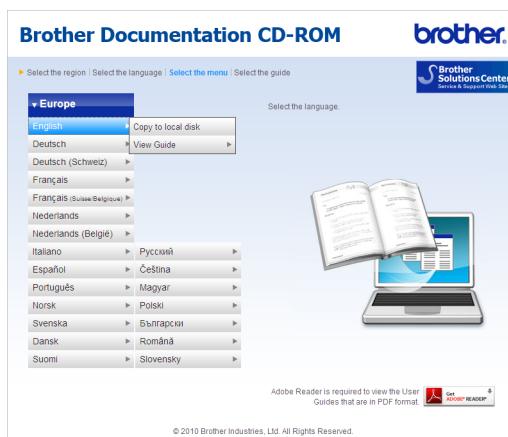

**Note**

- (Windows® users only) Your web browser may display a yellow bar at the top of the page that contains a security warning about Active X controls. For the page to display correctly you must click on **Allow Blocked Content**, then click **Yes** in the Security Warning dialog box.
- (Windows® users only) <sup>1</sup> For faster access, you can copy all user documentation in PDF format to a local folder on your computer. Point to your language, then click **Copy to local disk**.

<sup>1</sup> Microsoft® Internet Explorer® 6.0 or greater.

**How to find Scanning instructions**

There are several ways you can scan documents. You can find the instructions as follows:

**Software User's Guide**

- *Scanning*
- *ControlCenter*
- *Network Scanning*  
(For DCP-7055W / DCP-7057W /  
DCP-7065DN / DCP-7070DW)

**ScanSoft™ PaperPort™ 12SE with OCR How-to-Guides****(Windows®)**

- The complete ScanSoft™ PaperPort™ 12SE with OCR How-to-Guides can be viewed from the Help section in the ScanSoft™ PaperPort™ 12SE application.

**Presto! PageManager User's Guide****(Macintosh)****Note**

Presto! PageManager must be downloaded and installed before use. See *Accessing Brother Support (Macintosh)* on page 5 for further instructions.

- The complete Presto! PageManager User's Guide can be viewed from the Help section in the Presto! PageManager application.

**How to find Network setup instructions**

(For DCP-7055W / DCP-7057W /  
DCP-7065DN / DCP-7070DW)

Your machine can be connected to a wireless or wired network. You can find basic setup instructions in the *Quick Setup Guide*. If your wireless access point or router supports Wi-Fi Protected Setup or AOSS™, you can also follow the steps in the *Quick Setup Guide*. For more information about network setup please see the *Network User's Guide*.

# Accessing Brother Support (Windows®)

You can find all the contacts you will need, such as Web support (Brother Solutions Center) on the Installation CD-ROM.

- Click **Brother Support** on the main menu. The following screen will appear:

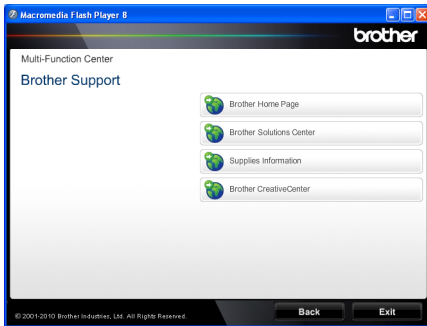

- To access our website (<http://www.brother.com/>), click **Brother Home Page**.
- For the latest news and product support information (<http://solutions.brother.com/>), click **Brother Solutions Center**.
- To visit our website for original Brother Supplies (<http://www.brother.com/original/>), click **Supplies Information**.
- To access the Brother CreativeCenter (<http://www.brother.com/creativecenter/>) for FREE photo projects and printable downloads, click **Brother CreativeCenter**.
- To return to the main page, click **Back** or if you have finished, click **Exit**.



# Accessing Brother Support (Macintosh)

You can find all the contacts you will need, such as Web support (Brother Solutions Center) on the Installation CD-ROM.

- Double-click the **Brother Support** icon. The following screen will appear:

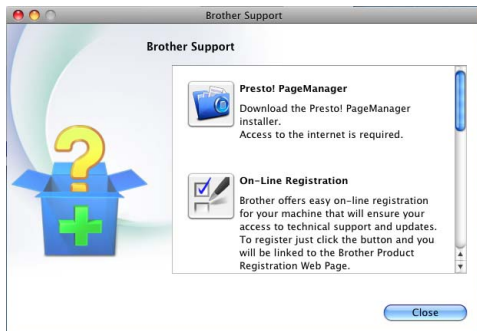

- To download and install Presto! PageManager, click **Presto! PageManager**.
- To register your machine from the Brother Product Register Page (<http://www.brother.com/registration/>), click **On-Line Registration**.
- For the latest news and product support information (<http://solutions.brother.com/>), click **Brother Solutions Center**.
- To visit our website for original Brother Supplies (<http://www.brother.com/original/>), click **Supplies Information**.

## Control panel overview

DCP-7055 / DCP-7055W / DCP-7057 / DCP-7057W have the same keys and DCP-7060D / DCP-7065DN / DCP-7070DW have the same keys.

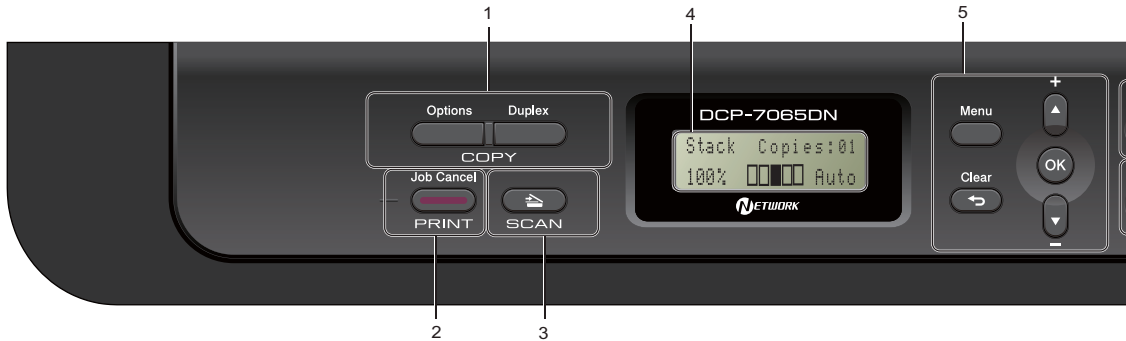

### 1 COPY keys:

#### Options

You can quickly and easily choose temporary settings for copying. These settings include:

Quality

Stack (choose number of copies)

Sort (For DCP-7065DN when using the ADF)

Brightness

Contrast

Enlarge/Reduce

Page Layout

#### Number of Copies

(For DCP-7055 / DCP-7055W / DCP-7057 / DCP-7057W)

Use this key to make multiple copies.

#### Duplex

(For DCP-7060D / DCP-7065DN / DCP-7070DW)

You can choose Duplex to copy on both sides of the paper.

### 2 PRINT key:

#### Job Cancel

Cancels a print job and clears it from the machine's memory. To cancel multiple print jobs, hold down this key until the LCD shows Job Cancel (All).

### 3 SCAN key

Puts the machine in Scan mode.



#### 4 LCD

Displays messages to help you set up and use your machine.

(For DCP-7055W / DCP-7057W / DCP-7070DW) A four level indicator shows the current wireless signal strength if you are using a wireless connection.



#### 5 Menu keys:

##### Menu

Lets you access the Menu to program your settings in this machine.

##### Clear

Deletes entered data or lets you cancel the current setting.

▲ + or ▼ -

Press to scroll through the menus and options.

##### OK

Lets you store your settings in the machine.

#### 6 Stop/Exit

Stops an operation or exits from a menu.

#### 7 Start

Lets you start making copies or scanning.

## Changing LCD language

You can change the LCD language.

- 1 Press **Menu**.
- 2 Press **▲** or **▼** to choose 1.General Setup.  
Press **OK**.
- 3 Press **▲** or **▼** to choose 0.Local Language.  
Press **OK**.
- 4 Press **▲** or **▼** to choose your language.  
Press **OK**.
- 5 Press **Stop/Exit**.

# 2

## Loading paper

### Loading paper and print media

The machine can feed paper from the standard paper tray or manual feed slot.

When you put paper into the paper tray, note the following:

- If your application software supports paper size selection on the print menu, you can select it through the software. If your application software does not support it, you can set the paper size in the printer driver or by using the control panel buttons.

### Loading paper in the standard paper tray

You can load up to 250 sheets. Paper can be loaded up to the maximum paper mark (▼▼▼) on the sliding paper width guide. (For recommended paper to use, see *Paper capacity of the paper trays* on page 17.)

### Printing on plain paper, thin paper or recycled paper from the standard paper tray

- 1 Pull the paper tray completely out of the machine.

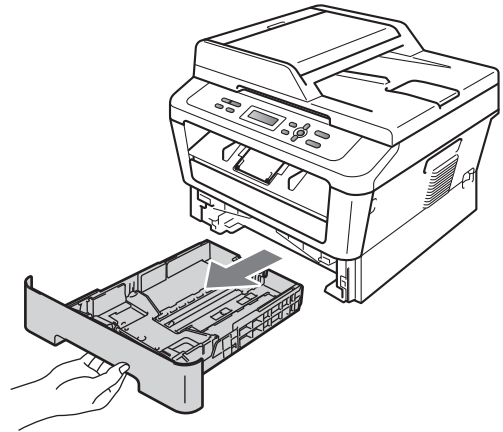

- 2 While pressing the green paper-guide release lever (1), slide the paper guides to fit the paper size you are loading in the tray. Make sure that the guides are firmly in the slots.

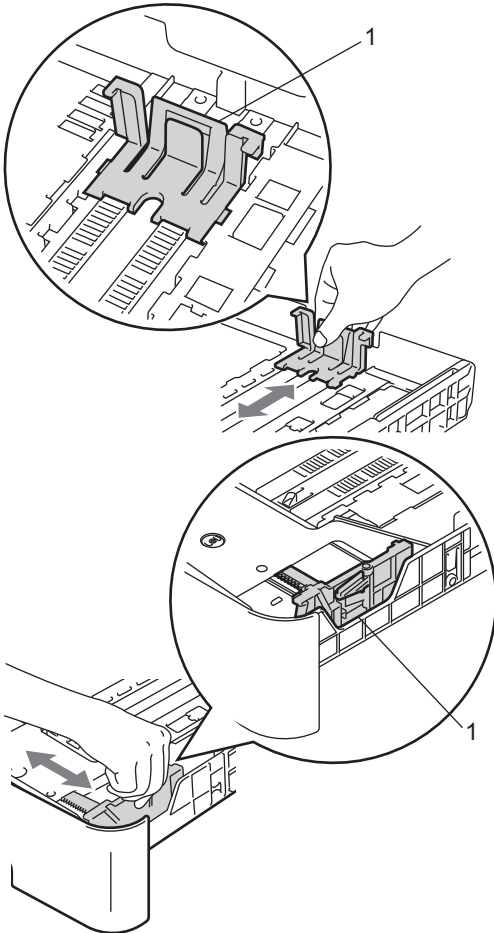

- 3 Fan the stack of paper well to avoid paper jams and misfeeds.

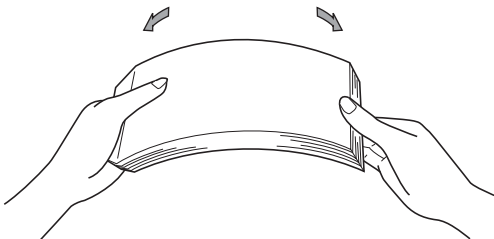

- 4 Put paper in the tray and make sure:

- The paper is below the maximum paper mark (▼▼▼) (1).

Overfilling the paper tray will cause paper jams.

- The side to be printed on must be *face down*.

- The paper guides touch the sides of the paper so it will feed correctly.

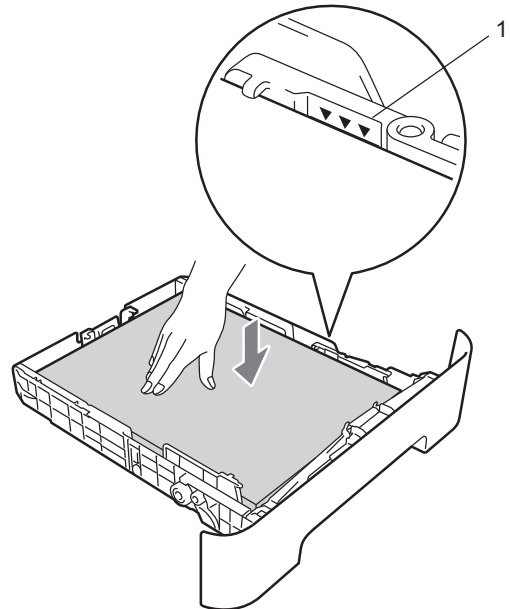

- 5 Put the paper tray firmly back in the machine. Make sure that it is completely inserted into the machine.

- 6 Unfold the support flap (1) to prevent paper from sliding off the face-down output tray.

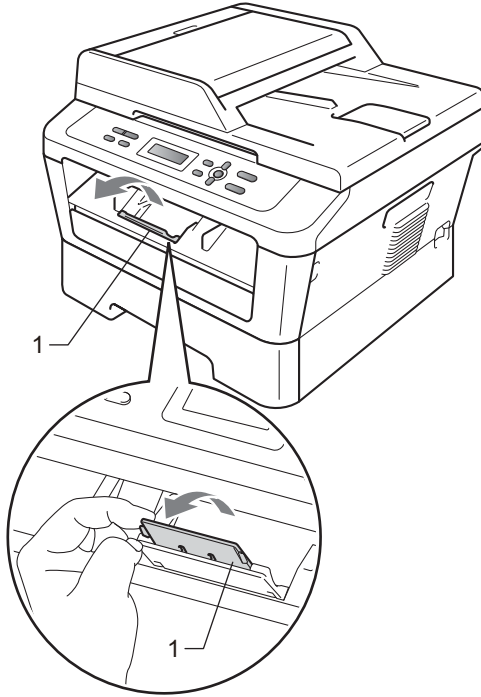

## Loading paper in the manual feed slot

You can load envelopes and special print media one at a time into this slot. Use the manual feed slot to print or copy on labels, envelopes or thicker paper.



### Note

The machine automatically turns on the Manual Feed mode when you put paper in the manual feed slot.

## Printing on plain paper or recycled paper from the manual feed slot

- 1 Unfold the support flap (1) to prevent paper from sliding off the face-down output tray, or remove each page as soon as it comes out of the machine.

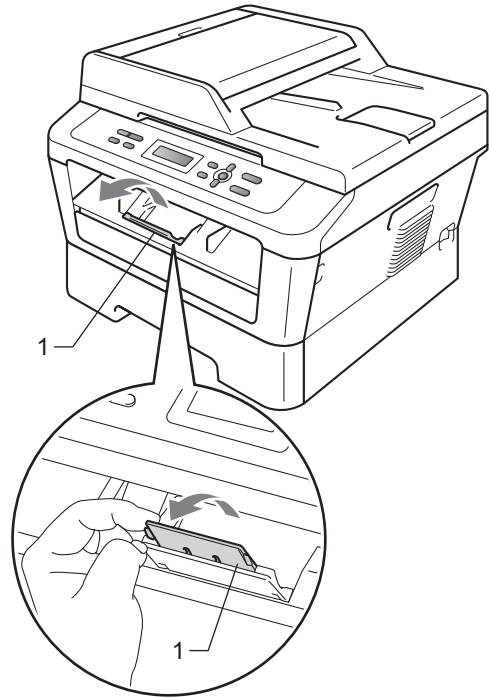

- 2 (For DCP-7060D / DCP-7065DN / DCP-7070DW)  
Open the manual feed slot cover.

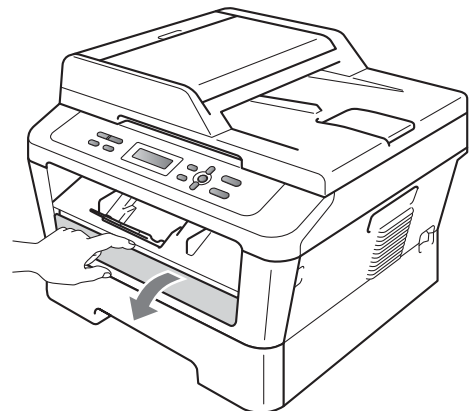

- Using both hands, slide the manual feed slot paper guides to the width of the paper that you are going to use.

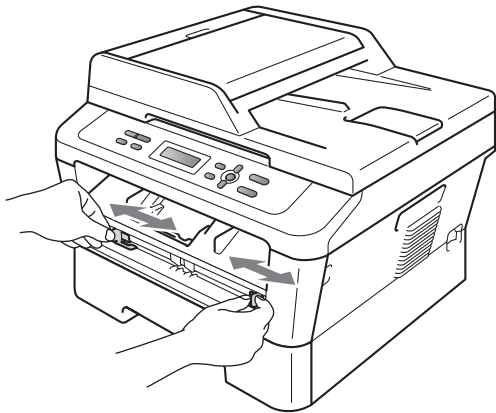

- Using both hands, put one sheet of paper in the manual feed slot until the front edge of the paper or transparency touches the paper feed roller. When you feel the machine pull in the paper, let go.

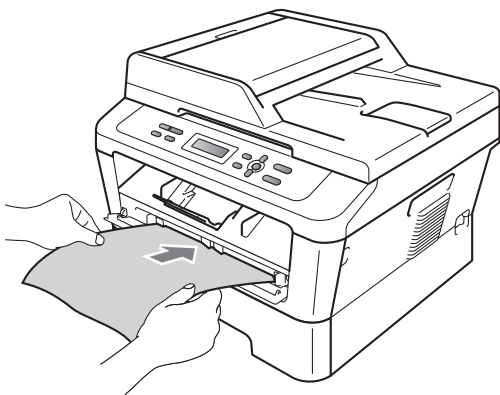

### Printing on thick paper, bond paper, labels, and envelopes

When the back output tray is pulled down, the machine has a straight paper path from the manual feed slot through to the back of the machine. Use this paper feed and output method when you want to print on thick paper, labels or envelopes.



### Note

Remove each printed sheet or envelope immediately to prevent a paper jam.

- Open the back cover (back output tray).

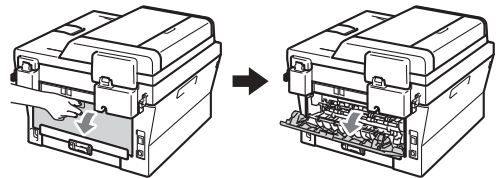

- (For printing envelopes)  
Pull down the two green levers, one on the left-hand side and one on the right-hand side, as shown in the illustration below.

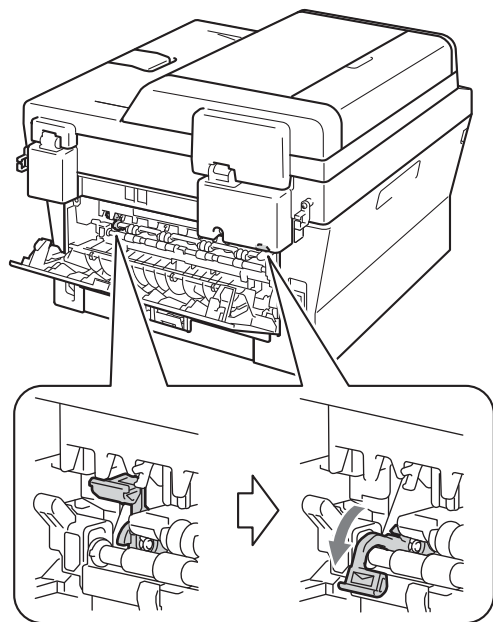



- 3 (For DCP-7060D / DCP-7065DN / DCP-7070DW)  
Open the manual feed slot cover.

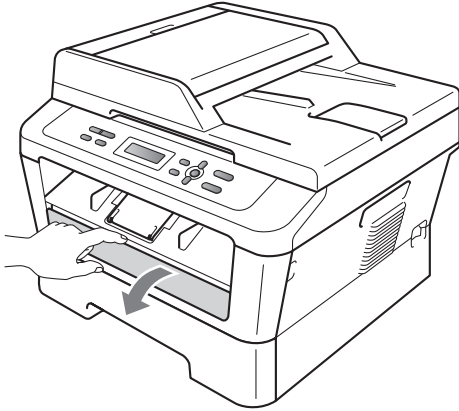

- 4 Using both hands, slide the manual feed slot paper guides to the width of the paper that you are going to use.

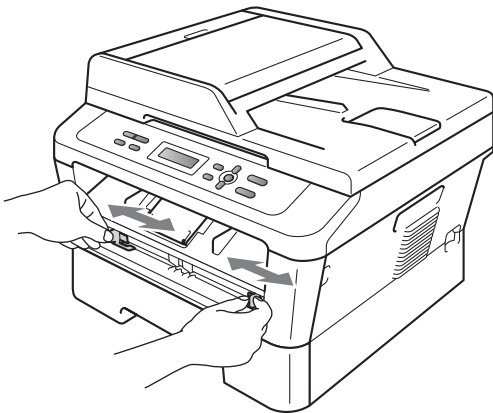

- 5 Using both hands, put one sheet of paper or one envelope in the manual feed slot until the front edge of the paper or envelope touches the paper feed roller. When you feel the machine pull in the paper, let go.

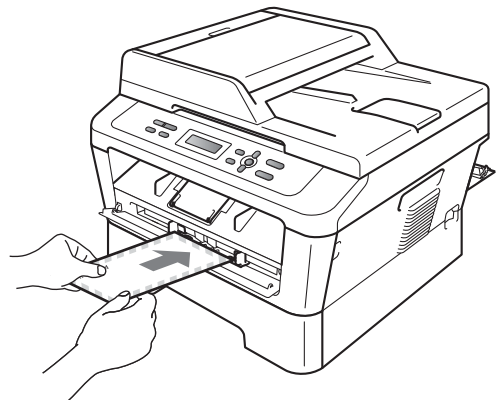
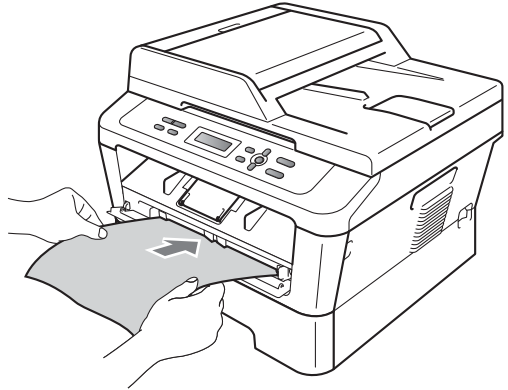

 **Note**

- Put the paper into the manual feed slot with the side to be printed face up.
- Make sure that the print media is straight and in the correct position on the manual feed slot. If it is not, the paper may not be fed correctly, resulting in a skewed printout or a paper jam.
- Do not put more than one sheet of paper in the manual feed slot at any one time, as it may cause a jam.

- If you put any print media in the manual feed slot before the machine is in Ready mode, the print media may be ejected without being printed on.
- To easily remove a small printout from the output tray, lift up the scanner cover by using both hands as shown in the illustration.

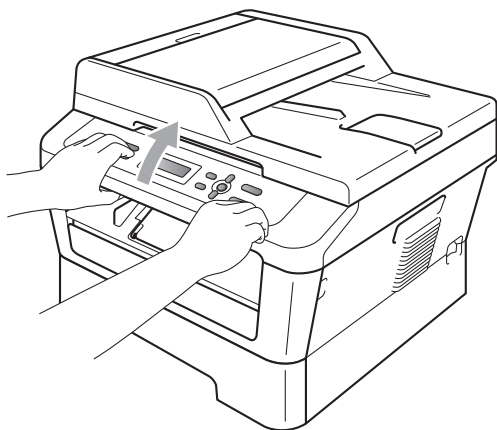

- You can still use the machine while the scanner cover is up. To close the scanner cover, push it down with both hands.

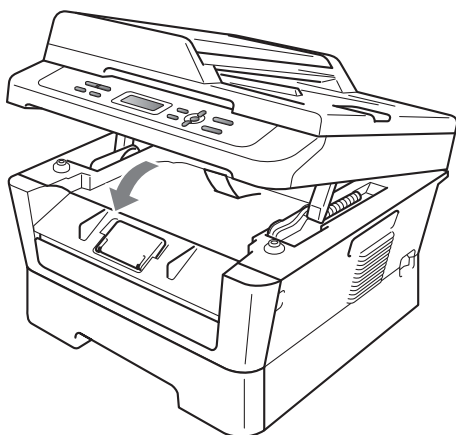

## Unscannable and unprintable areas

The figures below show maximum unscannable and unprintable areas. The unscannable and unprintable areas may vary depending on the paper size or settings in the application you are using.

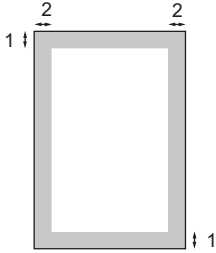

Usage	Document Size	Top (1) Bottom (1)	Left (2) Right (2)
Copy *a single copy or a 1 in 1 copy	Letter	3 mm	4 mm
	A4	3 mm	3 mm
Scan	Letter	3 mm	3 mm
	A4	3 mm	3 mm
Print	Letter	4 mm	6.35 mm
	A4	4 mm	6.35 mm

# Paper settings

## Paper Type

---

Set up the machine for the type of paper you are using. This will give you the best print quality.

- 1 Press **Menu**.
- 2 Press **▲** or **▼** to choose 1.General Setup.  
Press **OK**.
- 3 Press **▲** or **▼** to choose 1.Paper.  
Press **OK**.
- 4 Press **▲** or **▼** to choose 1.Paper Type.  
Press **OK**.
- 5 Press **▲** or **▼** to choose Thin, Plain, Thick, Thicker, Recycled Paper or Label.  
Press **OK**.
- 6 Press **Stop/Exit**.

- 5 Press **▲** or **▼** to choose A4, Letter, Executive, A5, A5 L, A6, B5 or B6.  
Press **OK**.

- 6 Press **Stop/Exit**.

## Paper Size

---

You can use several different sizes of paper for printing copies: A4, Letter, Executive, A5, A5 L, A6, B5 or B6.

When you change the size of paper in the tray, you will also need to change the setting for paper size at the same time so your machine can fit the document on the page.

- 1 Press **Menu**.
- 2 Press **▲** or **▼** to choose 1.General Setup.  
Press **OK**.
- 3 Press **▲** or **▼** to choose 1.Paper.  
Press **OK**.
- 4 Press **▲** or **▼** to choose 2.Paper Size.  
Press **OK**.

## Acceptable paper and other print media

Print quality may vary according to the type of paper you are using.

You can use the following types of print media: thin paper, plain paper, thick paper, bond paper, recycled paper, labels or envelopes.

For best results, follow the instructions below:

- DO NOT put different types of paper in the paper tray at the same time because it may cause paper jams or misfeeds.
- For correct printing, you must choose the same paper size from your software application as the paper in the tray.
- Avoid touching the printed surface of the paper immediately after printing.
- Before you buy a lot of paper, test a small quantity to make sure the paper is suitable.

## Recommended paper and print media

Paper Type	Item
Plain paper	Xerox Premier TCF 80 g/m <sup>2</sup>
	Xerox Business 80 g/m <sup>2</sup>
Recycled Paper	Xerox Recycled Supreme 80 g/m <sup>2</sup>
Labels	Avery laser label L7163
Envelope	Antalis River series (DL)

## Type and size of paper

The machine loads paper from the installed standard paper tray or manual feed slot.

**The name for the paper trays in the printer driver and this Guide are as follows:**

Tray and optional unit	Name
Standard paper tray	Tray 1
Manual feed slot	Manual

## Paper capacity of the paper trays

	Paper size	Paper type	No. of sheets
Paper Tray (Tray 1)	A4, Letter, B5, Executive, A5, A5 (Long Edge), A6, B6	Plain paper, Thin paper and Recycled paper	up to 250 [80 g/m <sup>2</sup> ]
Manual feed slot (Manual)	Width: 76.2 to 216 mm Length: 116 to 406.4 mm	Plain paper, Thin paper, Thick paper, Thicker paper, Bond paper, Recycled paper, Envelopes and Labels	Single sheet [80 g/m <sup>2</sup> ]

## Recommended paper specifications

The following paper specifications are suitable for this machine.

Basis weight	75-90 g/m <sup>2</sup>
Thickness	80-110 µm
Roughness	Higher than 20 sec.
Stiffness	90-150 cm <sup>3</sup> /100
Grain direction	Long grain
Volume resistivity	10e <sup>9</sup> -10e <sup>11</sup> ohm
Surface resistivity	10e <sup>9</sup> -10e <sup>12</sup> ohm-cm
Filler	CaCO <sub>3</sub> (Neutral)
Ash content	Below 23 wt%
Brightness	Higher than 80%
Opacity	Higher than 85%

- Use paper made for plain paper copying.
- Use paper that is 75 to 90 g/m<sup>2</sup>.
- Use long grain paper with a neutral Ph value, and a moisture content of approx. 5%.
- This machine can use recycled paper that meets DIN 19309 specifications.

## Handling and using special paper

The machine is designed to work well with most types of xerographic and bond paper. However, some paper variables may have an effect on print quality or handling reliability. Always test samples of paper before purchasing to ensure desirable performance. Store paper in its original packaging and keep it sealed. Keep the paper flat and away from moisture, direct sunlight and heat.

Some important guidelines when selecting paper are:

- DO NOT use inkjet paper because it may cause a paper jam or damage your machine.
- Preprinted paper must use ink that can withstand the temperature of the machine's fusing process 392 degrees Fahrenheit (200 degrees centigrade).

- If you use bond paper, paper that has a rough surface or paper that is wrinkled or creased, the paper may exhibit degraded performance.

### Types of paper to avoid

#### ! IMPORTANT

Some types of paper may not perform well or may cause damage to your machine.

DO NOT use paper:

- that is highly textured
- that is extremely smooth or shiny

- that is curled or warped

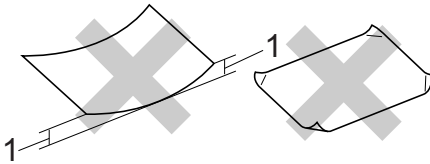

**1 A curl of 2 mm or greater may cause jams to occur.**

- that is coated or has a chemical finish
- that is damaged, creased or folded
- that exceeds the recommended weight specification in this guide
- with tabs and staples
- with letterheads using low temperature dyes or thermography
- that is multipart or carbonless
- that is designed for inkjet printing

If you use any of the types of paper listed, they may damage your machine. This damage is not covered under any Brother warranty or service agreement.

## Envelopes

Most envelopes designed for laser printers will be suitable for your machine. However, some envelopes may have feed and print-quality problems because of the way they have been made. A suitable envelope should have edges with straight, well-creased folds and the leading edge should not be thicker than two sheets of paper. The envelope should lie flat and not be of baggy or flimsy construction. You should buy quality envelopes from a supplier who understands that you will be using the envelopes in a laser machine.

Envelopes can be fed from manual feed slot one at a time. We recommend that you print a test envelope to make sure the print results are what you want before you print or purchase a large quantity of envelopes.

## Types of envelopes to avoid

### ! IMPORTANT

DO NOT use envelopes:

- that are damaged, curled, wrinkled or an unusual shape
- that are extremely shiny or textured
- with clasps, staples, snaps or tie strings
- with self-adhesive closures
- that are of a baggy construction
- that are not sharply creased
- that are embossed (have raised writing on them)
- that were previously printed by a laser machine
- that are pre-printed on the inside
- that cannot be arranged neatly when stacked
- that are made of paper that weighs more than the paper weight specifications for the machine
- with edges that are not straight or consistently square
- with windows, holes, cut-outs or perforations
- with glue on surface as shown in figure below

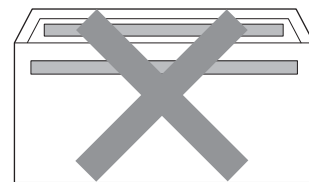

- with double flaps as shown in figure below

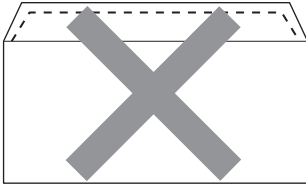

- with sealing flaps that are not folded down when purchased
- with sealing flaps as shown in figure below

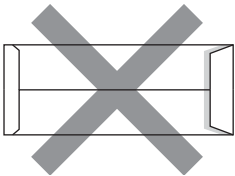

- with each side folded as shown in figure below

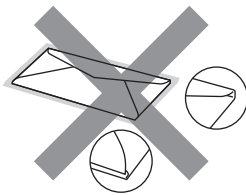

If you use any of the types of envelopes listed above, they may damage your machine. This damage may not be covered under any Brother warranty or service agreement.

## Labels

The machine will print on most types of labels designed for use with a laser machine. Labels should have an adhesive that is acrylic-based since this material is more stable at the high temperatures in the fuser unit. Adhesives should not come in contact with any part of the machine, because the label stock may stick to the drum unit or rollers and cause jams and print quality problems. No adhesive should be exposed between the labels. Labels should be arranged so that they cover the entire length and width of the sheet. Using labels with spaces may result in labels peeling off and causing serious jams or print problems.

All labels used in this machine must be able to withstand a temperature of 392 degrees Fahrenheit (200 degrees centigrade) for a period of 0.1 seconds.

Do not feed a label sheet through the machine more than one time.

## Types of labels to avoid

Do not use labels that are damaged, curled, wrinkled or an unusual shape.

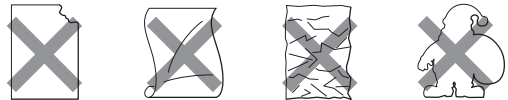

## ! IMPORTANT

- DO NOT feed part used label sheets. The exposed carrier sheet will damage your machine.
- Label sheets should not exceed the paper weight specifications described in this User's Guide. Labels exceeding this specification may not feed or print correctly and may cause damage to your machine.
- DO NOT insert labels that have previously been used, or have any labels missing from the sheet.



## How to load documents

You can make copies and scan from the ADF\* (Automatic Document Feeder) (\*For DCP-7065DN) and the scanner glass.

### Using the automatic document feeder (ADF) (For DCP-7065DN)

The ADF can hold up to 35 pages and feeds each sheet individually. Use standard 80 g/m<sup>2</sup> paper and always fan the pages before putting them in the ADF.

#### Document Sizes Supported

Length:	147.3 to 355.6 mm
Width:	147.3 to 215.9 mm
Weight:	64 to 90 g/m <sup>2</sup>

#### How to load documents

### ! IMPORTANT

- DO NOT leave thick documents on the scanner glass. If you do this, the ADF may jam.
- DO NOT use paper that is curled, wrinkled, folded, ripped, stapled, paper-clipped, pasted or taped.
- DO NOT use cardboard, newspaper or fabric.
- To avoid damaging your machine while using the ADF, DO NOT pull on the document while it is feeding.



#### Note

- To scan documents that are not suitable for the ADF, see *Using the scanner glass* on page 22.
- It is easier to use the ADF if you are loading a multiple page document.
- Make sure documents with correction fluid or written with ink are completely dry.

- 1 Lift up and unfold the ADF document output support flap (1).  
Unfold the ADF document support (2).

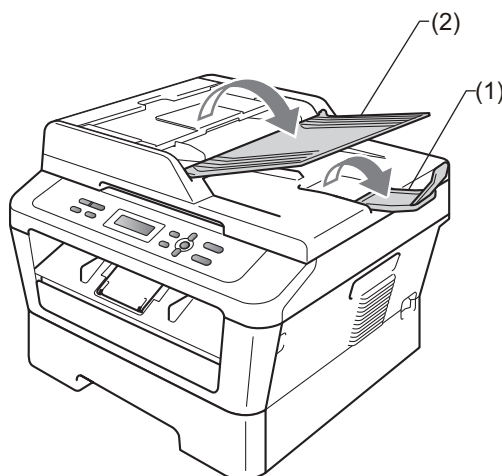

- 2 Fan the pages well.
- 3 Place your document *face up top edge first*, in the ADF until the LCD display message changes and you feel it touch the feed rollers.

- Adjust the paper guides (1) to fit the width of your document.

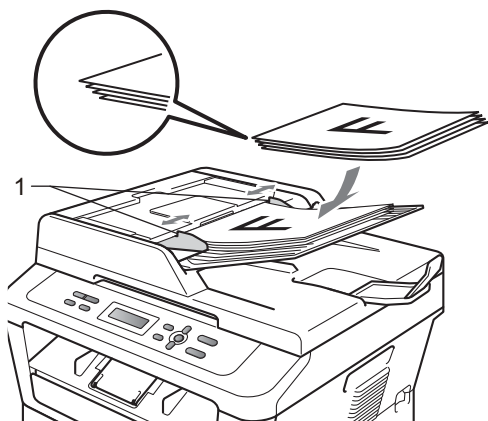

- Using the document guidelines on the left and top, place the document *face down* in the upper left corner of the scanner glass.

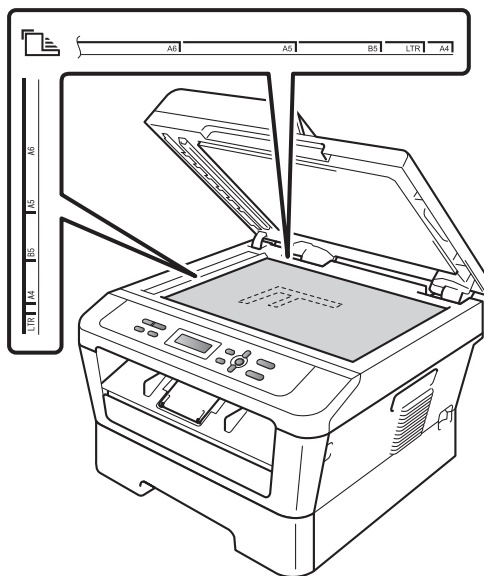

### ! IMPORTANT

- To avoid damaging your machine while using the ADF, **DO NOT** pull on the document while it is feeding.
- To scan non-standard documents, see *Using the scanner glass* on page 22.

## Using the scanner glass

You can use the scanner glass to copy or scan pages of a book one page at a time.

### Document Sizes Supported

Length:	Up to 297.0 mm
Width:	Up to 215.9 mm
Weight:	Up to 2.0 kg

### How to load documents



#### Note

To use the scanner glass, the ADF must be empty.

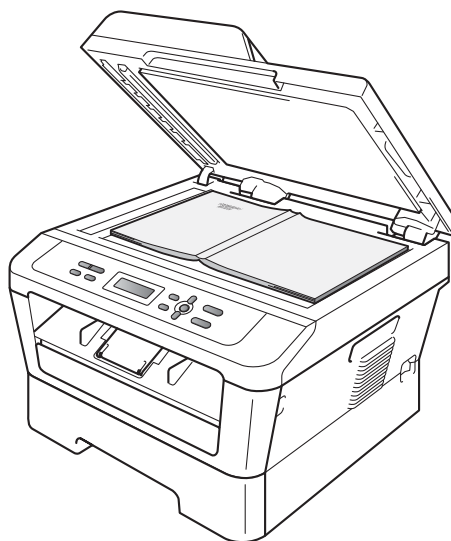

- Lift the document cover.

- 3 Close the document cover.

**! IMPORTANT**

If the document is a book or is thick, do not slam or press on the cover.

# 4

## Making copies

### How to copy

The following steps show the basic copy operation. For details about each option, see the *Advanced User's Guide* on the CD-ROM.



```
Stack   Copies:01
100%   □□■□□ Auto
```

- 1 Do one of the following to load your document:
  - (For DCP-7065DN) Place the document *face up* in the ADF. (See *Using the automatic document feeder (ADF) (For DCP-7065DN)* on page 21.)
  - Load your document *face down* on the scanner glass. (See *Using the scanner glass* on page 22.)
- 2 If you make a single copy, press **Start**. If you make multiple copies, do one of the following:
  - (For DCP-7055 / DCP-7055W / DCP-7057 / DCP-7057W) Press **Number of Copies** to enter the number of copies (up to 99) and press **Start**.
  - Press or hold ▲ or ▼ to increase or decrease the number of copies and press **Start**.

### Stop copying

To stop copying, press **Stop/Exit**.

### Copy settings

You can change the following copy settings:

Press **Menu**, **Options** or **Duplex** and then press ▲ or ▼ to scroll through the copy settings. When the setting you want is displayed, press **OK**.

For details about changing the copy settings, see *Copy settings* in *Chapter 2* of the *Advanced User's Guide*.

You can change the following copy settings:

- Enlarge/Reduce
- Quality
- Stack (up to 99 copies)
- Sort <sup>1</sup>
- Brightness
- Contrast
- Page Layout
- Duplex <sup>2</sup>

<sup>1</sup> For DCP-7065DN

<sup>2</sup> For DCP-7060D, DCP-7065DN and DCP-7070DW

## Printing a document

The machine can receive data from your computer and print it. To print from a computer, install the printer driver. (See *Printing for Windows*<sup>®</sup> or *Printing and Faxing* for Macintosh in the *Software User's Guide* for the details about the print settings.)

- 1 Install the Brother printer driver on the Installation CD-ROM. (See the *Quick Setup Guide*.)
- 2 From your application, choose the Print command.
- 3 Choose the name of your machine in the **Print** dialog box and click **Properties**.
- 4 Choose the settings you want in the **Properties** dialog box.
  - Paper Size
  - Orientation
  - Copies
  - Media Type
  - Resolution
  - Print Settings
  - Multiple Page
  - Duplex / Booklet<sup>1</sup>
  - Paper Source
- 5 Click **OK** to begin printing.

<sup>1</sup> For DCP-7060D / DCP-7065DN / DCP-7070DW

# 6

## How to scan to a computer

### Scanning a document as PDF file using ControlCenter4 (Windows®)

(For Macintosh users) See *Scanning* in the *Software User's Guide*.



#### Note

The screens on your PC may vary depending on your model.

ControlCenter4 is a software utility that lets you quickly and easily access the applications you use most often. Using ControlCenter4 eliminates the need to manually launch specific applications. You can use ControlCenter4 on your computer.

- 1 Load your document. (See *How to load documents* on page 21.)
- 2 Open ControlCenter4 by clicking **start/All Programs/Brother/XXX-XXXX** (where XXX-XXXX is your model name)/**ControlCenter4**. The ControlCenter4 application will open.
- 3 Choose **Home Mode** or **Advanced Mode** before you use ControlCenter4.

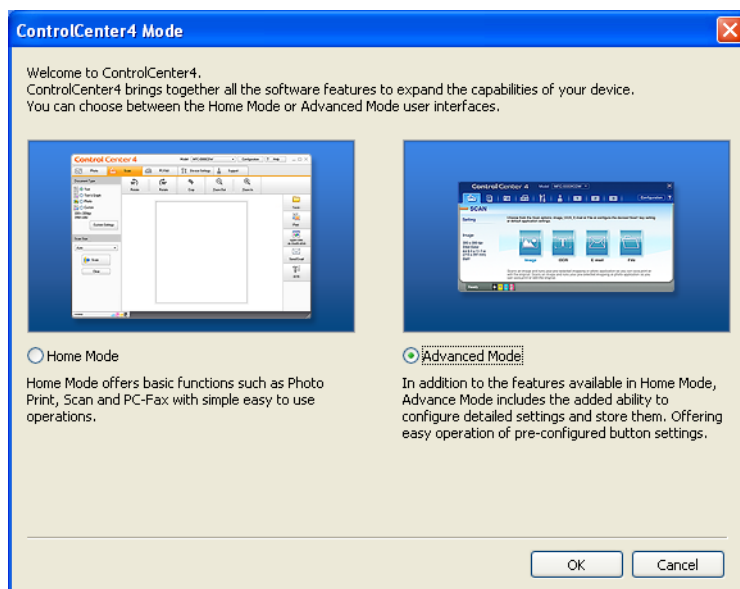

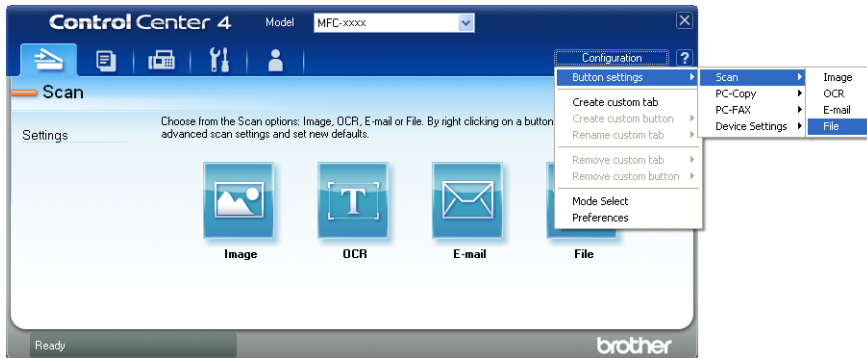

- 4 Make sure the machine you want to use is selected from the **Model** pull-down list.

- 5 Set the file type for saving to a folder.  
Click **Configuration**, and then select **Button settings, Scan and File**.

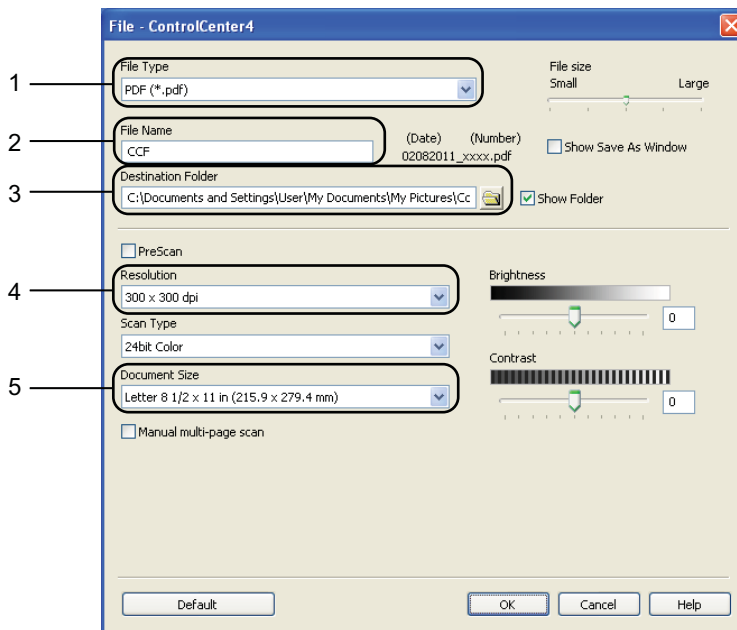

The configuration dialog box appears. You can change the default settings.



- 1 Choose **PDF (\*.pdf)** from the **File Type** pull-down list.
- 2 You can enter the file name you want to use for the document.
- 3 You can save the file to the default folder, or choose your preferred folder by clicking the  **Browse** button.
- 4 You can choose a scanning resolution from the **Resolution** pull-down list.
- 5 You can choose the document size from the pull-down list.

- 6 Click **OK**.

- 7 Click **File**.  
The machine starts the scanning process. The folder where the scanned data is saved will open automatically.

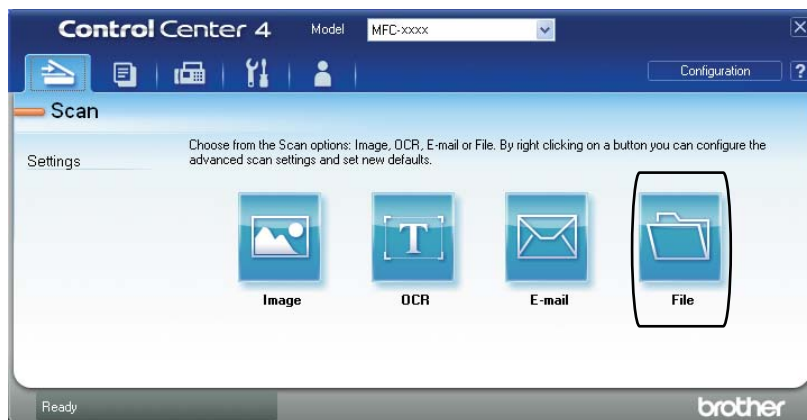



# Changing the SCAN key settings

## Before scanning

To use the machine as a scanner, install a scanner driver. If the machine is on a network, configure it with a TCP/IP address.

- Install the scanner drivers on the Installation CD-ROM. (See the *Quick Setup Guide*.)
- Configure the machine with a TCP/IP address if network scanning does not work. (See *Configuring Network Scanning* in the *Software User's Guide*.)

## SCAN key settings

You can change your machine's **SCAN** key settings using ControlCenter4.

- 1 Open ControlCenter4 by clicking **start/All Programs/Brother/XXX-XXXX** (where XXX-XXXX is your model name)/**ControlCenter4**. The ControlCenter4 application will open.
- 2 Make sure the machine you want to use is selected from the **Model** pull-down list.
- 3 Click the **Device Settings** tab.
- 4 Click **Device Scan Settings**.

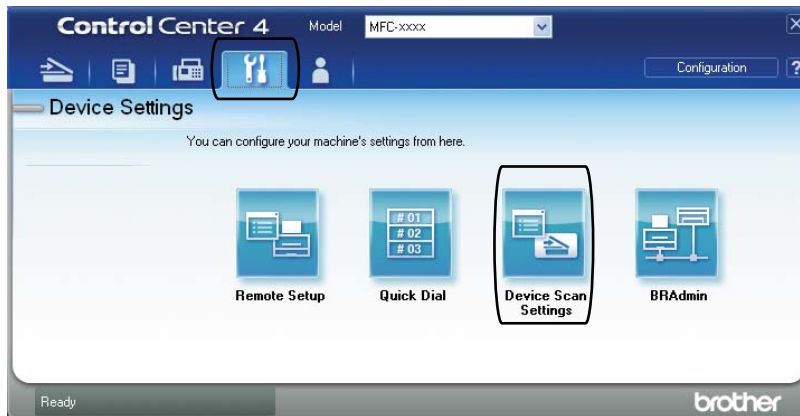

- 5 Choose the **File** tab. You can change the default settings.

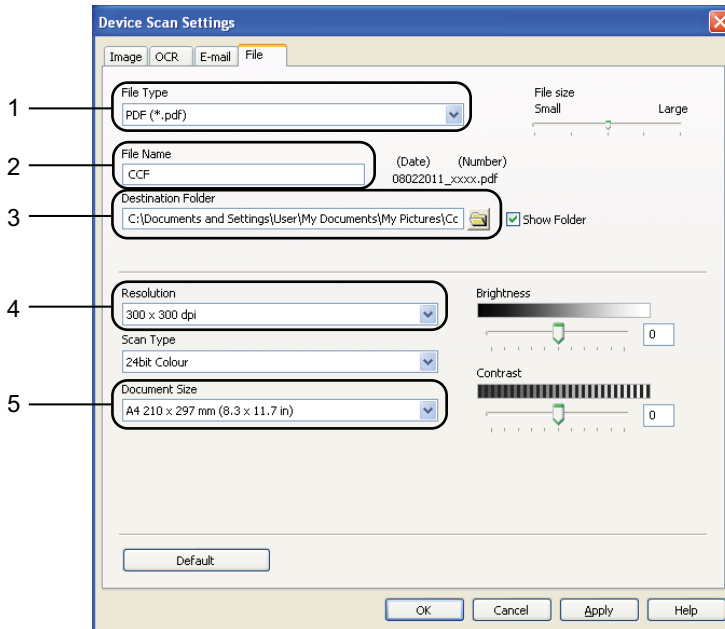

- 1 You can choose the file type from the pull-down list.
- 2 You can enter the file name you want to use for the document.
- 3 You can save the file to the default folder, or choose your preferred folder by clicking the  **Browse** button.
- 4 You can choose a scanning resolution from the **Resolution** pull-down list.
- 5 You can choose the document size from the pull-down list.

- 6 Click **OK**.

## Scanning using the SCAN key

---

- 1 Load your document. (See *How to load documents* on page 21.)
- 2 Press  (**SCAN**).
- 3 Press ▲ or ▼ to choose **Scan to PC**.  
Press **OK**.
- 4 Press ▲ or ▼ to choose **File**.  
Press **OK**.
- 5 (For Network users)  
Press ▲ or ▼ to choose the destination computer you want to send to.  
Press **OK**.  
If the LCD prompts you to enter a PIN number, enter the 4-digit PIN number for the destination computer using the dial pad on the control panel.  
Press **OK**.
- 6 Press **Start**.  
The machine starts the scanning process.



### Note

---

Choose the scan mode you want.

Scan to:

- E-mail (Scan to PC)
  - Image (Scan to PC)
  - OCR (Scan to PC)
  - File (Scan to PC)
-

# A

## Routine maintenance

### Replacing the consumable items

The machine will indicate when it is time to replace the consumable items. (See *Replacing the toner cartridge* on page 33 and *Replacing the drum unit* on page 39.) To avoid any inconvenience, you may want to buy spare consumable items before the machine stops printing.

Russian customers: Please refer to the Russian guide for information on your consumable items.

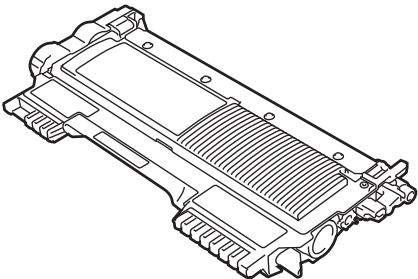
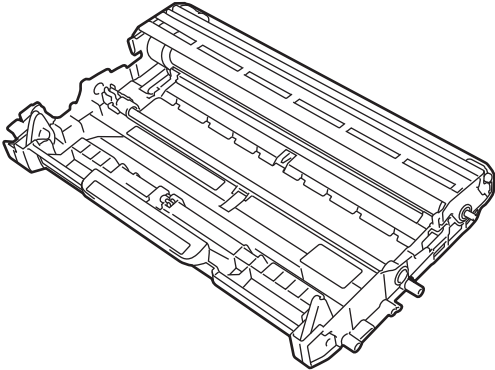
Toner cartridge	Drum unit
<p>See <i>Replacing the toner cartridge</i> on page 33.</p> <p>Model Name: (For DCP-7055 / DCP-7055W / DCP-7057) TN-2010, (For DCP-7060D / DCP-7065DN / DCP-7070DW) TN-2210, TN-2220</p>	<p>See <i>Replacing the drum unit</i> on page 39.</p> <p>Model Name: DR-2200</p>
	

#### Note

- If you choose not to return your used consumable, please discard the used consumable according to local regulations, keeping it separate from domestic waste. If you have questions, call your local waste disposal office. (See *EU Directive 2002/96/EC and EN 50419* in the *Safety and Legal booklet*.)
- We recommend placing used consumable items on a piece of paper to prevent accidentally spilling or scattering the material inside.
- If you use paper that is not a direct equivalent for the recommended paper, the life of consumable items and machine parts may be reduced.
- The projected life of the toner cartridges is based on ISO/IEC 19752. Frequency of replacement will vary depending on the complexity of printed pages, percentage of coverage and type of media used.

## Replacing the toner cartridge

Model Name: For the model name of toner cartridges, see *Replacing the consumable items* on page 32.

The Standard toner cartridge can print approximately 1,000 pages (TN-2010) or 1,200 pages (TN-2210)<sup>1</sup>. The High Yield toner cartridge (For DCP-7060D / DCP-7065DN / DCP-7070DW) can print approximately 2,600 pages<sup>1</sup>. Actual page count will vary depending on your average type of document. When a toner cartridge is running low, the LCD shows **Toner Low**.

(For DCP-7065DN and DCP-7070DW)

The toner cartridge that comes supplied with the machine is a Standard toner cartridge.

(For DCP-7055 / DCP-7055W / DCP-7057 / DCP-7060D)

The toner cartridge that comes supplied with the machine is a Starter toner cartridge that will need to be replaced after approximately 700 pages<sup>1</sup>.

<sup>1</sup> Approx. cartridge yield is declared in accordance with ISO/IEC 19752.

## ! IMPORTANT

Brother machines are designed to work with toner of a particular specification and will work to a level of optimum performance when used with genuine Brother Original toner cartridges. Brother cannot guarantee this optimum performance if toner or toner cartridges of other specifications are used. Brother does not therefore recommend the use of cartridges other than genuine Brother Original cartridges with this machine, or the refilling of empty cartridges with toner from other sources. If damage is caused to the drum unit or other part of this machine as a result of the use of toner or toner cartridges other than genuine Brother Original products due to the incompatibility or lack of suitability of those products with this machine, any repairs required as a result may not be covered by the warranty.



### Note

- It is a good idea to keep a new toner cartridge ready for use when you see the **Toner Low** warning.
- To ensure high quality printing, we recommend that you use only Brother Original toner cartridges. When you want to buy toner cartridges, please call your Brother dealer.
- We recommend that you clean the machine when you replace the toner cartridge. See *Cleaning the machine* on page 44.
- If you change the print density setting for lighter or darker printing, the amount of toner used will change.
- Wait to unpack the toner cartridge until immediately before you put it into the machine.

## Toner Low

Toner Low

If the LCD shows **Toner Low**, buy a new toner cartridge and have it ready before you get a **Replace Toner** message.

## Replace Toner

When the following message appears on the LCD, you need to replace the toner cartridge:

Replace Toner

The machine will stop printing until you replace the toner cartridge. A new and unused original Brother toner cartridge will reset the **Replace Toner** mode.



### Note

To force the machine to continue printing after the LCD shows **Replace Toner**, set the machine to **Continue** mode (Press **Menu**, press **▲** or **▼** to choose **1.General Setup** and press **OK**, press **▲** or **▼** to choose **4.Replace Toner**, and press **OK**, press **▲** or **▼** to choose **Continue** and press **OK**. The machine will continue printing until the LCD shows **Toner Ended**. (For details about the Toner settings, see *Toner Settings* in *Chapter 1 of the Advanced User's Guide*.)

## Toner Ended

Toner Ended

The machine stops printing until you replace the toner cartridge with a new one. (See *Replacing the toner cartridge* on page 34.)

## Replacing the toner cartridge

- 1 Make sure that the machine is turned on.
- 2 Open the front cover and leave the machine turned on for 10 minutes to cool down.

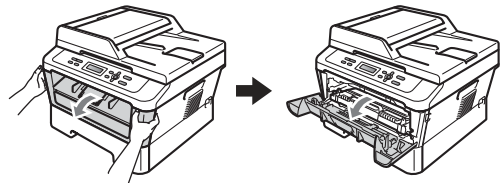

**⚠ WARNING**

**🔥 HOT SURFACE**

After you have just used the machine, some internal parts of the machine will be extremely hot. When you open the front or back cover (back output tray) of the machine, DO NOT touch the shaded parts shown in the illustration. If you do this, you may burn yourself.

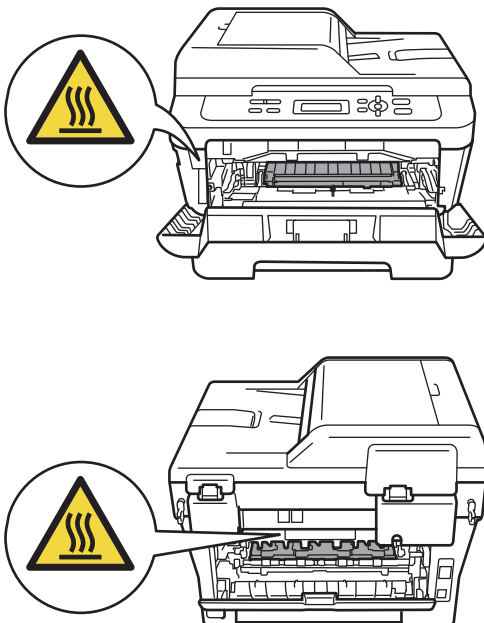

- 3 Take out the drum unit and toner cartridge assembly.

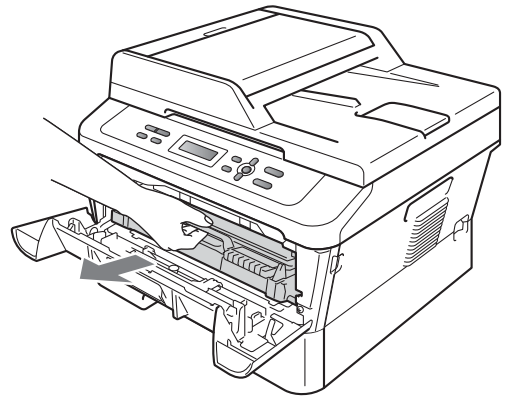

- 4 Push down the green lock lever and take the toner cartridge out of the drum unit.

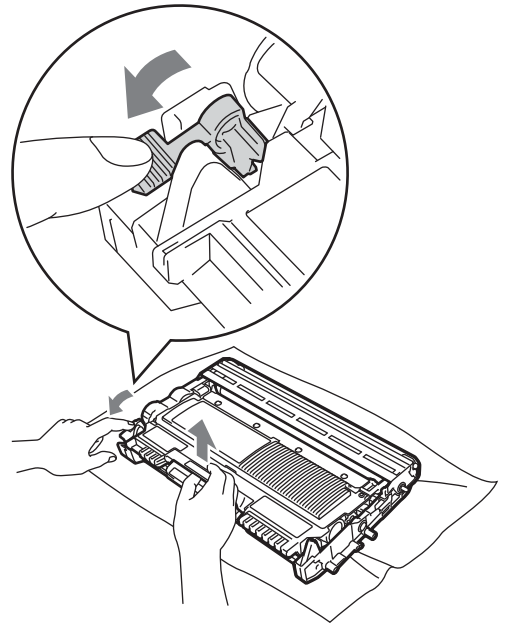

A

## ⚠ WARNING

DO NOT put a toner cartridge into a fire. It could explode, resulting in injuries.

DO NOT use cleaning materials that contain ammonia, alcohol, any type of spray or any type of flammable substance to clean the inside or outside of the machine. Doing this may cause a fire or electrical shock.

See *To use the product safely* in the *Safety and Legal booklet* for how to clean the machine.



Be careful not to inhale toner.

## ! IMPORTANT

- We recommend that you place the drum unit and/or the toner cartridge on a clean, flat, level, stable surface with a sheet of disposable paper or cloth underneath it in case you accidentally spill or scatter toner.
- Handle the toner cartridge carefully. If toner scatters on your hands or clothes, immediately wipe or wash it off with cold water.
- To avoid print quality problems, DO NOT touch the shaded parts shown in the illustration.

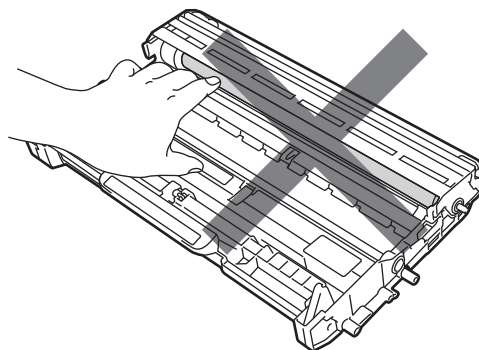
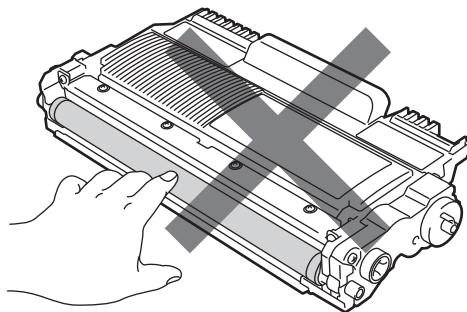



 **Note**

- Be sure to seal up the toner cartridge tightly in a suitable bag so that toner powder does not spill out of the cartridge.
- If you choose not to return your used consumable, please discard the used consumable according to local regulations, keeping it separate from domestic waste. If you have questions, call your local waste disposal office. (See *EU Directive 2002/96/EC and EN 50419* in the *Safety and Legal booklet*.)

- 5 Unpack the new toner cartridge. Hold the cartridge level with both hands and gently shake it from side to side several times to spread the toner evenly inside the cartridge.

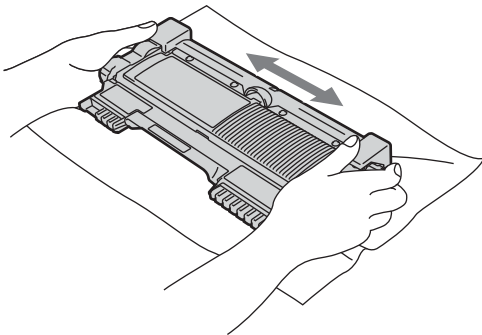

 **IMPORTANT**

Unpack the toner cartridge just before you put it in the machine. If a toner cartridge is left unpacked for a long time, the toner life will be shortened.

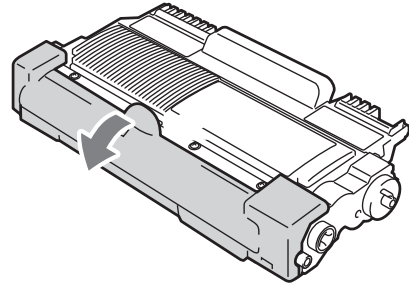
- 6 Pull off the protective cover.

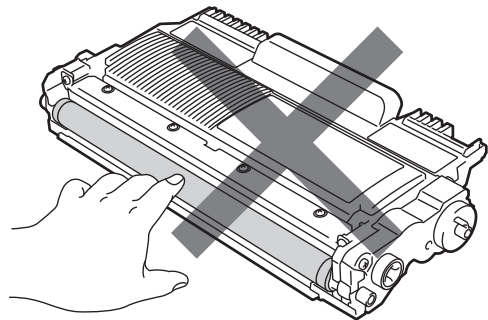

 **IMPORTANT**

Put the toner cartridge in the drum unit immediately after you have removed the protective cover. To prevent any degradation to the print quality, **DO NOT** touch the shaded parts shown in the illustrations.

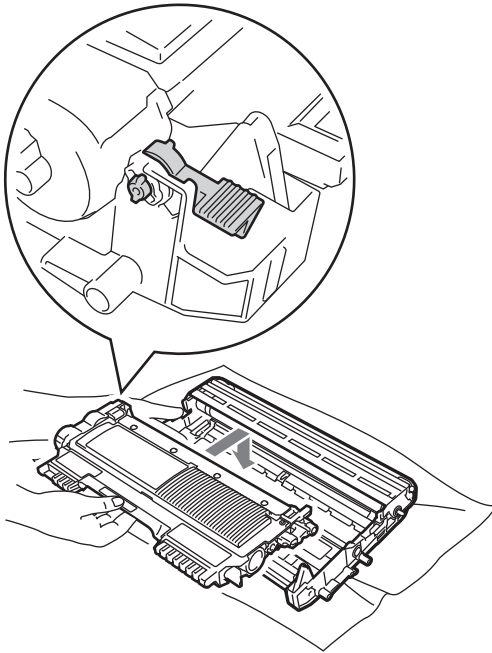
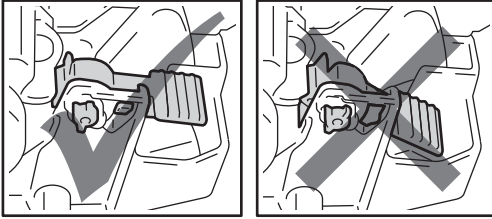

A

- 7 Put the new toner cartridge firmly into the drum unit so that it locks into place. If you put it in correctly, the green lock lever will lift automatically.



- 8 Clean the primary corona wire inside the drum unit by gently sliding the green tab from left to right and right to left several times.

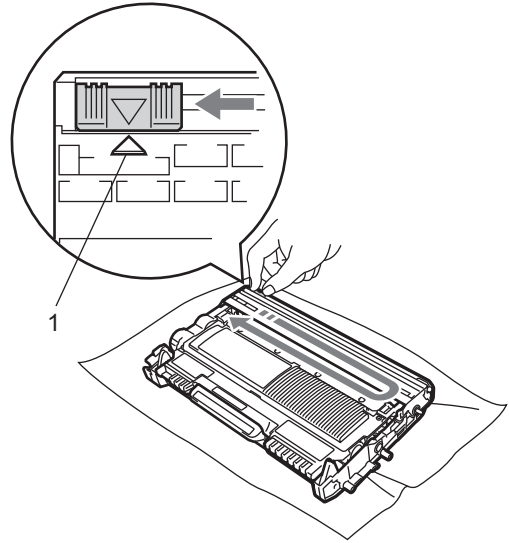

 **Note**

Be sure to return the tab to the home position (▲) (1). If you do not, printed pages may have a vertical stripe.

- 9 Put the drum unit and toner cartridge assembly back into the machine. Close the front cover.

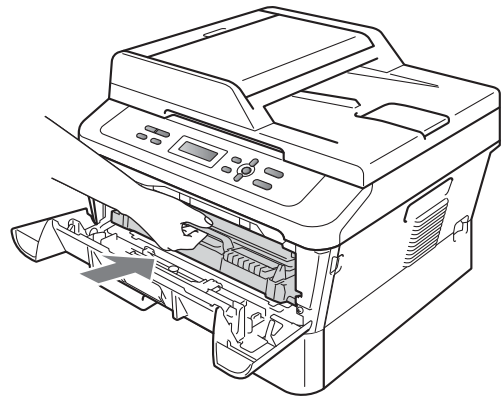

**Note**

After replacing the toner cartridge, DO NOT turn off the machine's power switch or open the front cover until the LCD returns to Ready mode.

## Replacing the drum unit

Model name: DR-2200

A new drum unit can print approximately 12,000 A4 or Letter size single-sided pages.

### ! IMPORTANT

For best performance, use only genuine Brother Original drum unit and genuine Brother Original toner cartridges. Printing with a third-party drum unit or toner cartridge may reduce not only the print quality but also the quality and life of the machine itself. Warranty coverage may not apply to problems caused by the use of a third-party drum or toner cartridge.

### Drum Error

Drum Error

The corona wire has become dirty. Clean the corona wire in the drum unit. (See *Cleaning the corona wire* on page 46.)

If you cleaned the corona wire and Drum Error was not cleared, replace the drum unit with a new one.

### Replace Drum

Replace Drum

Please replace the drum unit with a new one. We recommend a genuine Brother Original drum unit be installed at this time.

After replacement, reset the drum counter by following the instructions included with the new drum unit.

### Drum Stop

Drum Stop

We cannot guarantee the print quality. Please replace the drum unit with a new one. We recommend a genuine Brother Original drum unit be installed at this time.

After replacement, reset the drum counter by following the instructions included with the new drum unit.

### Replacing the drum unit

### ! IMPORTANT

- While removing the drum unit, handle it carefully because it may contain toner. If toner scatters on your hands or clothes, immediately wipe or wash it off with cold water.
- Every time you replace the drum unit, clean the inside of the machine. (See *Cleaning the machine* on page 44.)

- 1 Make sure that the machine is turned on.
- 2 Open the front cover and leave the machine turned on for 10 minutes to cool down.

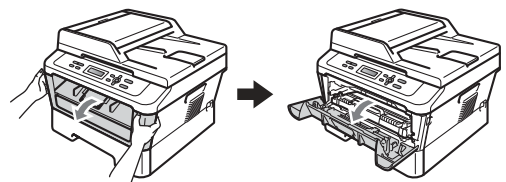

## WARNING

### HOT SURFACE

After you have just used the machine, some internal parts of the machine will be extremely hot. When you open the front or back cover (back output tray) of the machine, DO NOT touch the shaded parts shown in the illustration. If you do this, you may burn yourself.

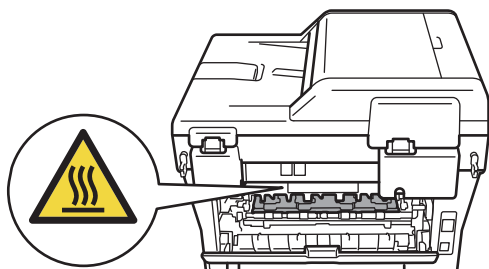
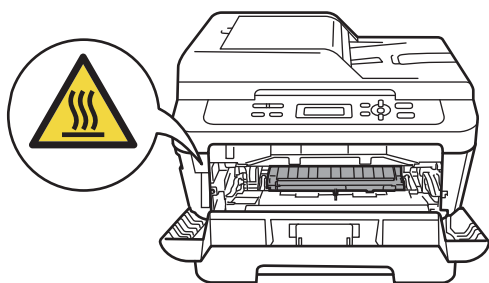

- 3 Take out the drum unit and toner cartridge assembly.

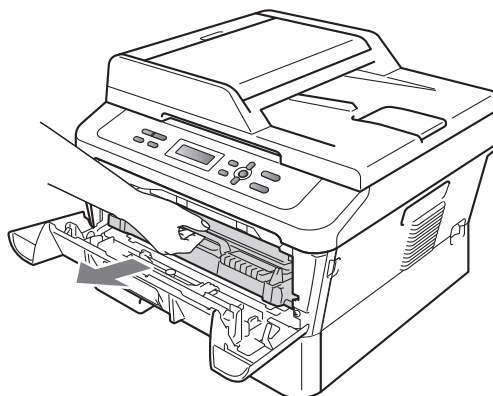

- 4 Push down the green lock lever and take the toner cartridge out of the drum unit.

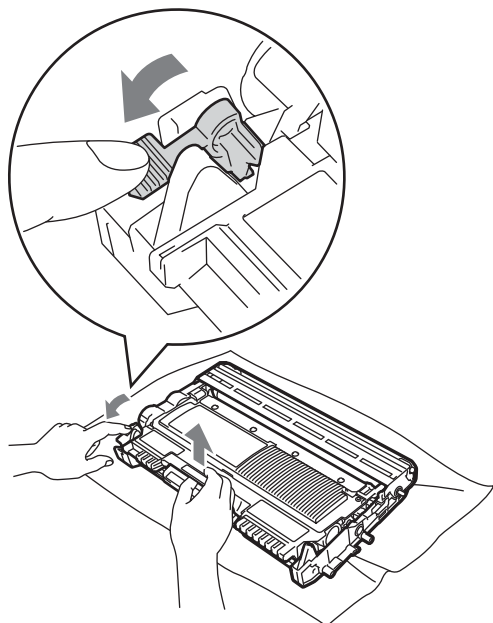

## ⚠ WARNING

DO NOT put a toner cartridge into a fire. It could explode, resulting in injuries.

DO NOT use cleaning materials that contain ammonia, alcohol, any type of spray, or any type of flammable substance to clean the outside or inside of the machine. Doing this may cause a fire or electrical shock.

See *To use the product safely* in the *Safety and Legal booklet* for how to clean the machine.



Be careful not to inhale toner.

## ! IMPORTANT

- To prevent damage to the machine from static electricity, DO NOT touch the electrodes shown in the illustration.

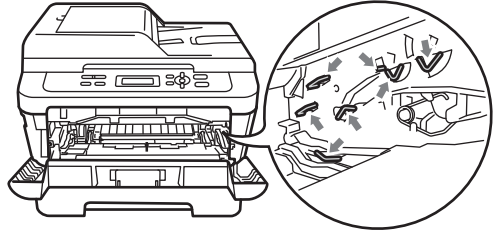

- Handle the toner cartridge carefully. If toner scatters on your hands or clothes, immediately wipe or wash it off with cold water.
- We recommend that you place the drum unit and/or the toner cartridge on a clean, flat surface with a sheet of disposable paper or cloth underneath it in case you accidentally spill or scatter toner.
- To avoid print quality problems, DO NOT touch the shaded parts shown in the illustrations.

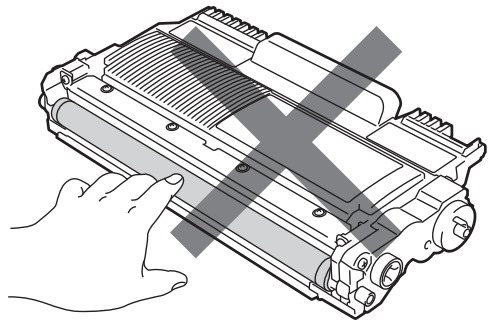

 **Note**

If you choose not to return your used consumable, please discard the used consumable according to local regulations, keeping it separate from domestic waste. If you have questions, call your local waste disposal office. (See *EU Directive 2002/96/EC and EN 50419* in the *Safety and Legal booklet*.)

**5** Unpack the new drum unit.

**! IMPORTANT**

- To avoid print quality problems, **DO NOT** touch the shaded parts shown in the illustrations.

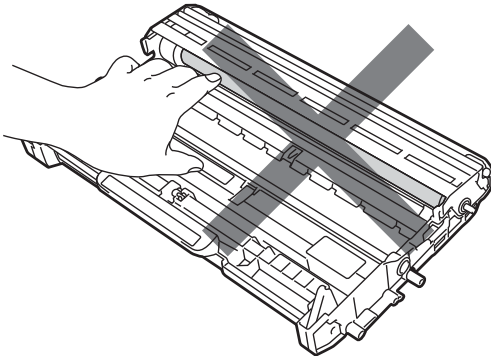

- Unpack the drum unit just before you put it in the machine. Exposure to direct sunlight or room light may damage the drum unit.

**6** Put the toner cartridge firmly into the new drum unit until you hear it lock into place. If you put the cartridge in correctly, the green lock lever will lift automatically.

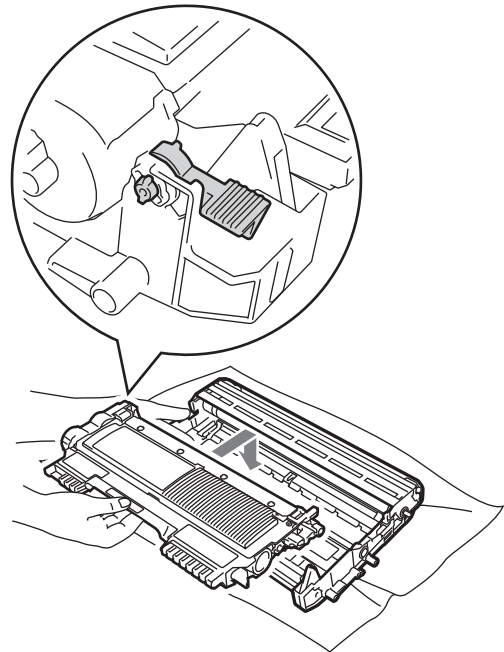
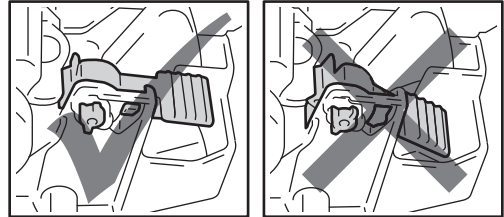

 **Note**

Make sure that you put in the toner cartridge correctly or it may separate from the drum unit.

- 7 Clean the corona wire of the drum unit by gently sliding the green tab from left to right and right to left several times.

### ! IMPORTANT

Be sure to return the green tab to the home position (▲) (1). If you do not, printed pages may have a vertical stripe.

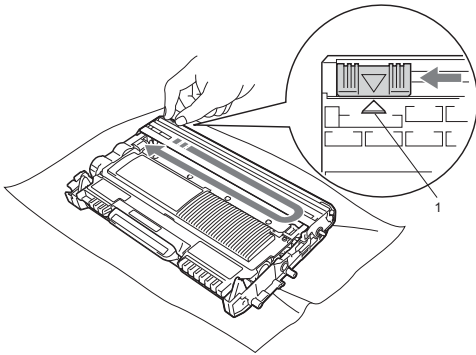

A

- 8 Put the new drum unit and toner cartridge assembly in the machine.

### Resetting the drum counter

When you replace the drum unit with a new one, you need to reset the drum counter by completing the following steps:

- 1 Open the front cover and press **Clear**. To confirm you are installing a new drum, press ▲.
- 2 When the LCD shows *Accepted*, close the front cover.

## Cleaning the machine

Clean the outside and inside of the machine regularly with a dry, lint-free soft cloth. When you replace the toner cartridge or the drum unit, make sure that you clean the inside of the machine.

### WARNING

DO NOT use any flammable substances, spray or organic solvent/liquids containing alcohol/ammonia to clean the outside or inside of the machine. Doing this may cause a fire or electrical shock.

See *To use the product safely* in the *Safety and Legal booklet* for how to clean the machine.



Be careful not to inhale toner.

### IMPORTANT

Use neutral detergents. Cleaning with volatile liquids such as thinner or benzine will damage the surface of the machine.

## Cleaning the outside of the machine

- 1 Turn off the machine. Disconnect all cables, and then unplug the power cord from the electrical socket.
- 2 Pull the paper tray completely out of the machine.

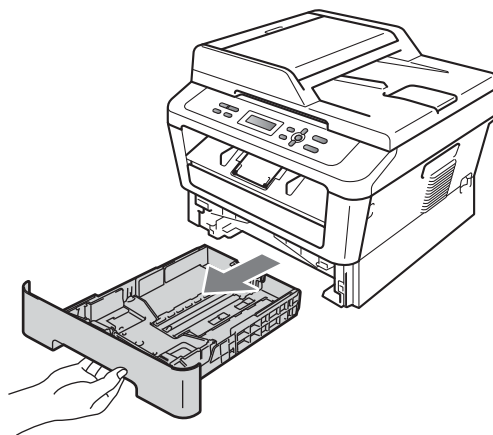

- 3 Wipe the outside of the machine with a dry, lint-free soft cloth to remove dust.

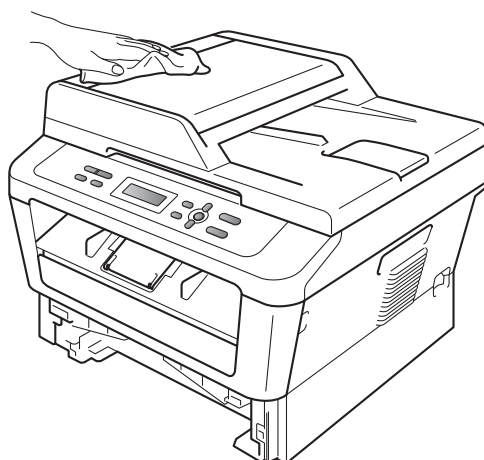

- 4 Remove any paper that is in the paper tray.



- 5 Wipe the inside and the outside of the paper tray with a dry, lint-free soft cloth to remove dust.

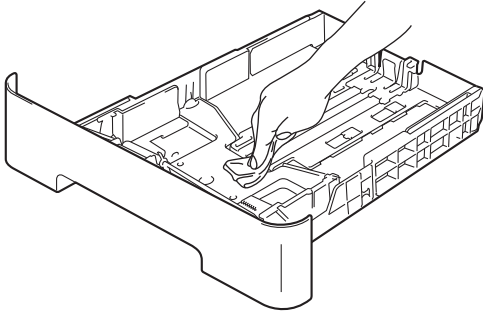

- 6 Re-load the paper and put the paper tray firmly back in the machine.
- 7 Plug the machine's power cord back into the electrical socket first, connect all cables. Turn on the machine.

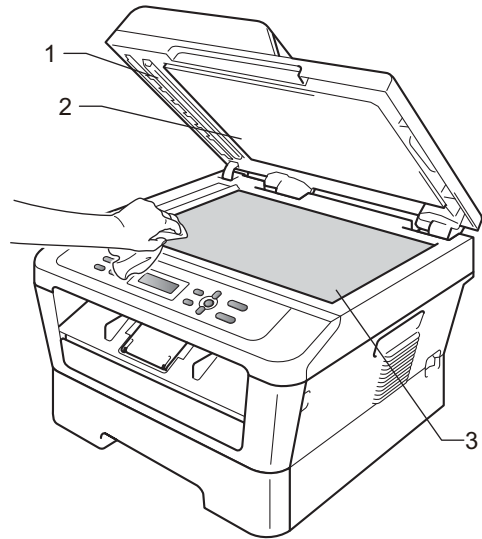

- 3 (For DCP-7065DN) In the ADF unit, clean the white bar (1) and the scanner glass strip (2) underneath it with a soft lint-free cloth moistened with water.

A

## Cleaning the scanner glass

- 1 Turn off the machine. Disconnect all cables, and then unplug the power cord from the electrical socket.
- 2 Lift the document cover (1). Clean the white plastic surface (2) and scanner glass (3) underneath it with a soft lint-free cloth moistened with water.

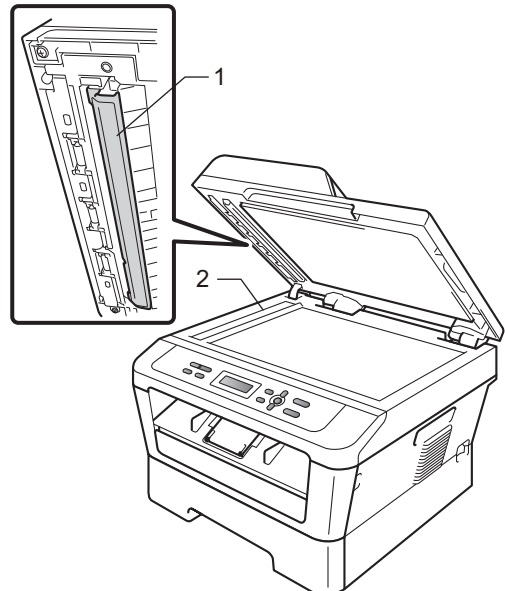

## Note

In addition to cleaning the scanner glass and glass strip with a soft lint-free cloth moistened with water, run your finger tip over the glass to see if you can feel anything on it. If you feel dirt or debris, clean the glass again concentrating on that area. You may need to repeat the cleaning process three or four times. To test, make a copy after each cleaning.

- 4 Plug the machine's power cord back into the electrical socket first, connect all cables. Turn on the machine.

## Cleaning the corona wire

If you have print quality problems, clean the corona wire as follows:

- 1 Open the front cover and leave the machine turned on for 10 minutes to cool down.

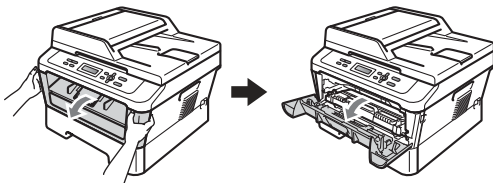

## WARNING

### HOT SURFACE

After you have just used the machine, some internal parts of the machine will be extremely hot. Wait for the machine to cool down before you touch the internal parts of the machine.

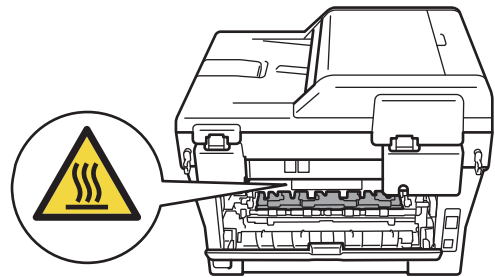
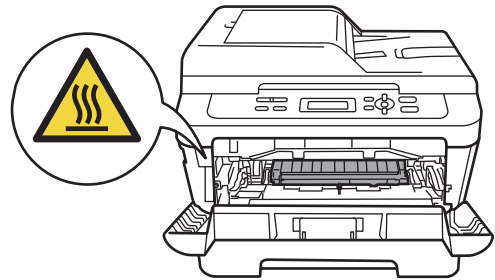

- 2 Slowly take out the drum unit and toner cartridge assembly.

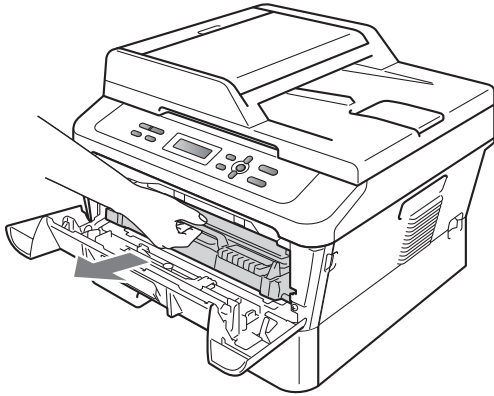

### ! IMPORTANT

- We recommend that you place the drum unit and toner cartridge assembly on a clean, flat surface with a sheet of disposable paper or cloth underneath it in case you accidentally spill or scatter toner.
- Handle the toner cartridge carefully. If toner scatters on your hands or clothes, wipe or wash it off with cold water at once.
- To prevent damage to the machine caused by static electricity, DO NOT touch the electrodes shown in the illustration.

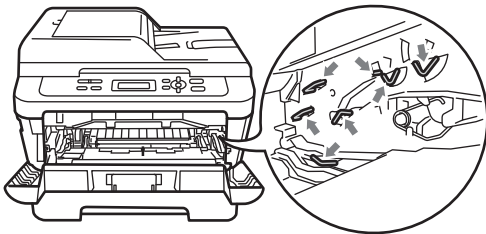

- 3 Clean the corona wire inside the drum unit by gently sliding the green tab from right to left and left to right several times.

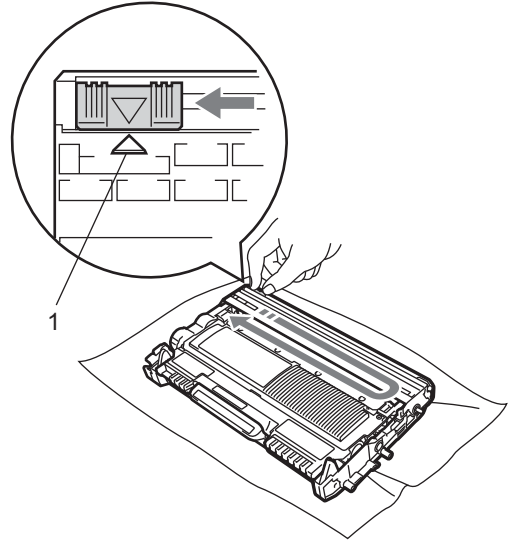

### Note

Be sure to return the tab to the home position (▲) (1). If you do not, printed pages may have a vertical stripe.

- 4 Put the drum unit and toner cartridge assembly back into the machine. Close the front cover.

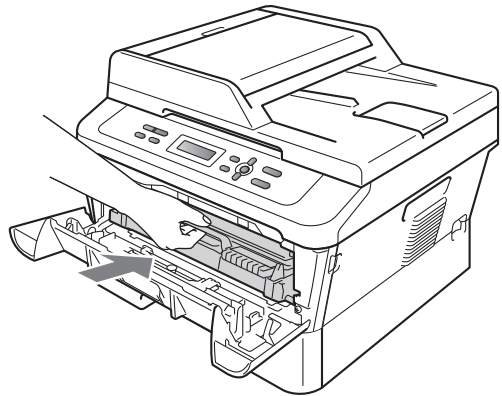

## Cleaning the drum unit

If you have print quality problems, the drum may have foreign material, such as glue from a label stuck on the drum surface. Follow the steps below to solve the problem.

- 1 Prepare blank A4 or Letter size paper.
- 2 Make sure the machine is in Ready mode.
- 3 Open the back cover (face-up output tray).

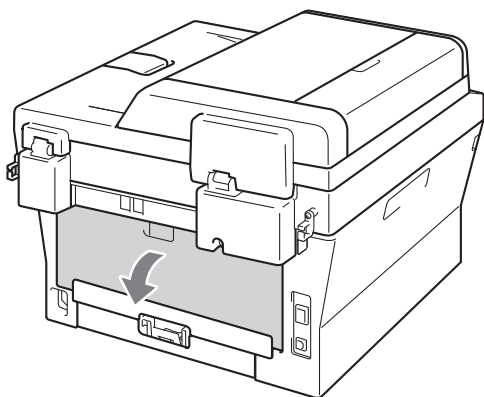

- 4 (For DCP-7060D / DCP-7065DN / DCP-7070DW)  
Open the manual feed slot cover.

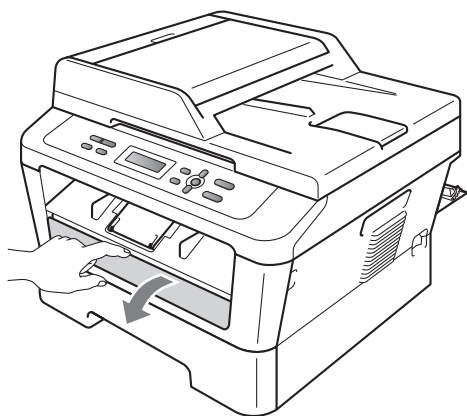

- 5 Press **Clear** and **Menu** at the same time. The **Drum Cleaning** message will appear on the LCD.
- 6 Using both hands, slide the manual feed paper guides to the width of the paper that you are going to use.

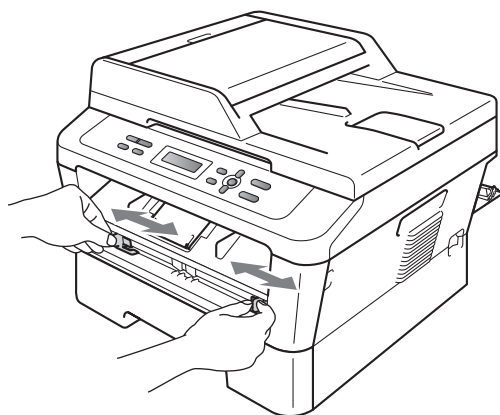

- 7 Using both hands, put one piece of A4 or Letter size paper in the manual feed slot until the top edge of the paper touches the paper feed roller. When you feel the machine pull in the paper, let go. The machine will start the Drum Cleaning process.

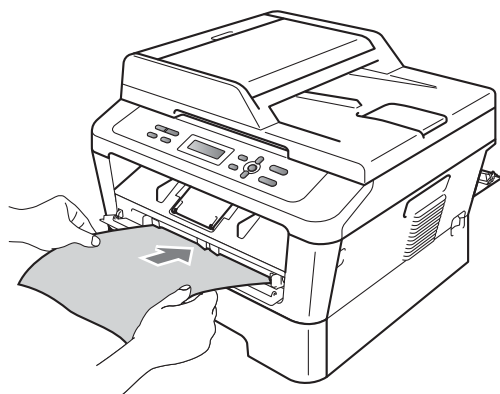

 **Note**

- The machine makes a mechanical noise during the Drum Cleaning process because the machine rotates the OPC drum in reverse. This noise is not due to a malfunction of the machine.
- DO NOT put more than one sheet of paper in the manual feed slot at any one time, as it may cause a jam.
- If the paper in the manual feed slot is other than A4 or Letter size, the machine will stop the Drum Cleaning process and eject the paper.
- Make sure that the paper is straight and in the correct position in the manual feed slot. If it is not, it may not be fed correctly, resulting in a paper jam.
- DO NOT close the back cover (face-up output tray) during the Drum Cleaning process. The machine will stop the Drum Cleaning process and eject the paper. It may cause a jam.
- If the machine receives a print job before you put one piece of paper in the manual feed slot, the machine stops the Drum Cleaning process and print the print job.

- 8 When the machine has finished cleaning, the machine returns to the Ready mode.
- 9 Repeat steps 5 to 8 two more times using a new blank sheet of paper each time. Upon completion please discard the used paper.

If the problem is not solved yet, follow the steps below.

- 1 Open the front cover and leave the machine turned on for 10 minutes to cool down.

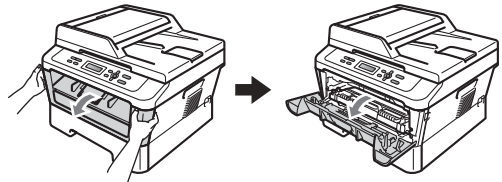
 **WARNING**
 **HOT SURFACE**

After you have just used the machine, some internal parts of the machine will be extremely hot. Wait for the machine to cool down before you touch the internal parts of the machine.

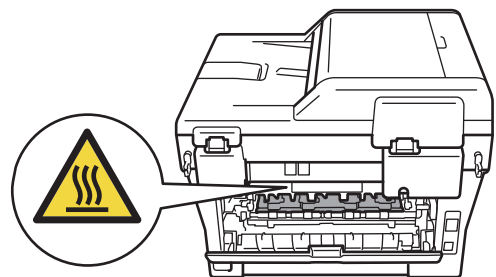
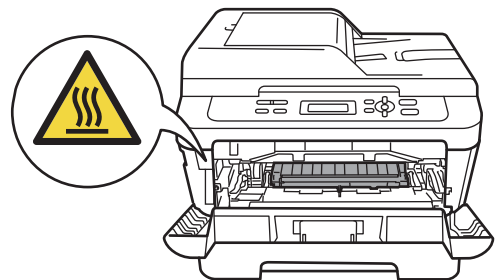

- 2 Slowly take out the drum unit and toner cartridge assembly.

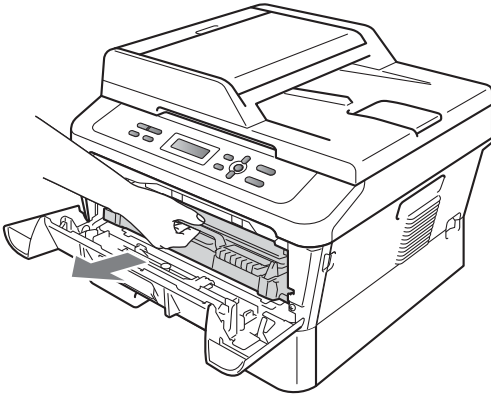

### ! IMPORTANT

- We recommend that you put the drum unit and toner cartridge assembly on a clean, flat surface with a sheet of disposable paper or cloth underneath it in case you accidentally spill or scatter toner.
- Handle the toner cartridge carefully. If toner scatters on your hands or clothes, wipe or wash it off with cold water at once.
- To prevent damage to the machine caused by static electricity, DO NOT touch the electrodes shown in the illustration.

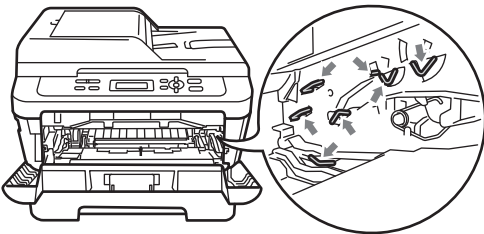

- 3 Push down the green lock lever and take the toner cartridge out of the drum unit.

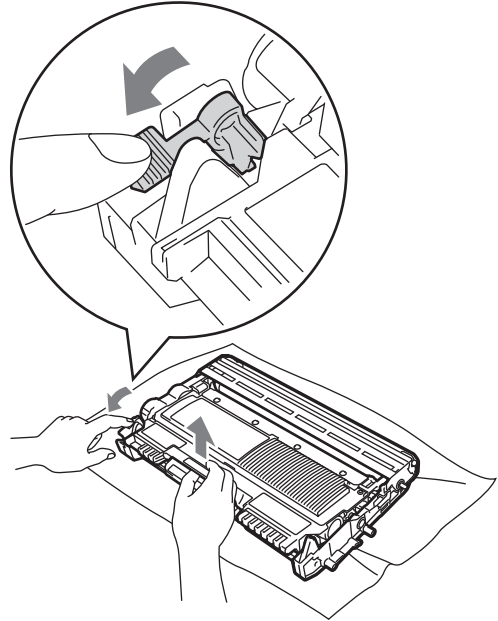

### ! IMPORTANT

- To avoid print quality problems, DO NOT touch the shaded parts shown in the illustrations below.

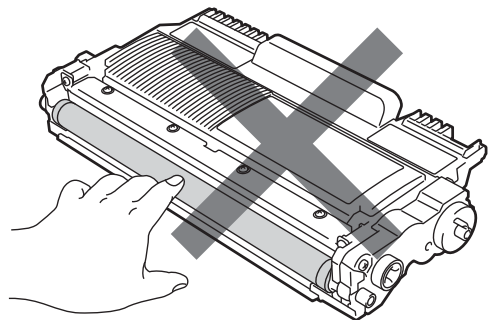

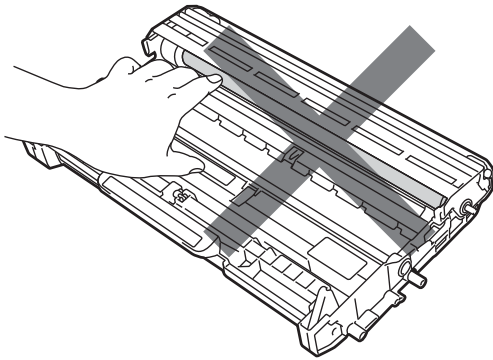

- To prevent damage to the machine from static electricity, **DO NOT** touch the electrodes shown in the illustration.

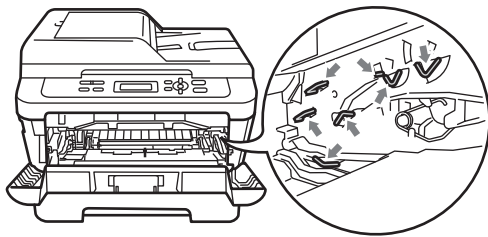

- 4** Put the print sample in front of the drum unit, and find the exact position of the poor print.

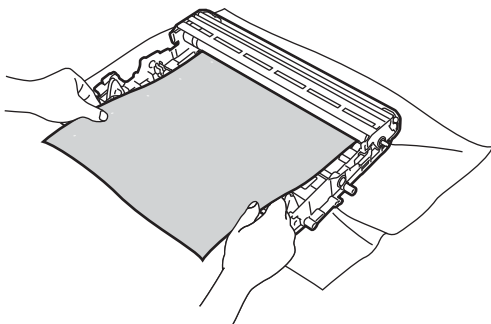

- 5** Turn the drum unit gear by hand while looking at the surface of the OPC drum (1).

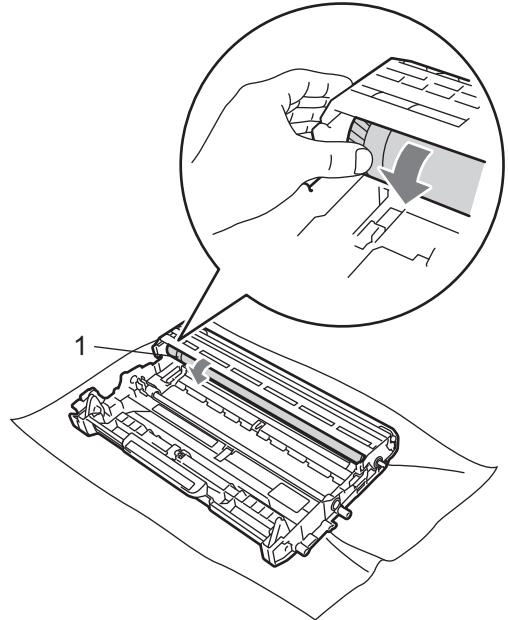

- 6** When you have found the mark on the drum that matches the print sample, wipe the surface of the OPC drum with a dry cotton swab until the dust or glue on the surface comes off.

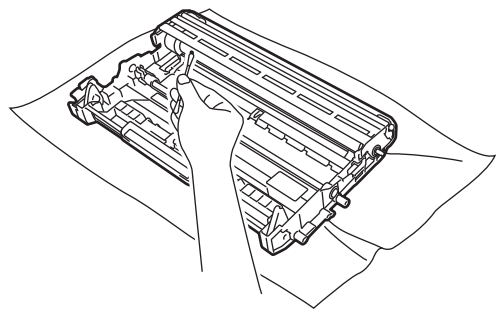

**! IMPORTANT**

**DO NOT** clean the surface of the photosensitive drum with a sharp object or any liquids.



- 7 Put the toner cartridge back into the drum unit until you hear it lock into place. If you put the cartridge in correctly, the green lock lever will lift automatically.

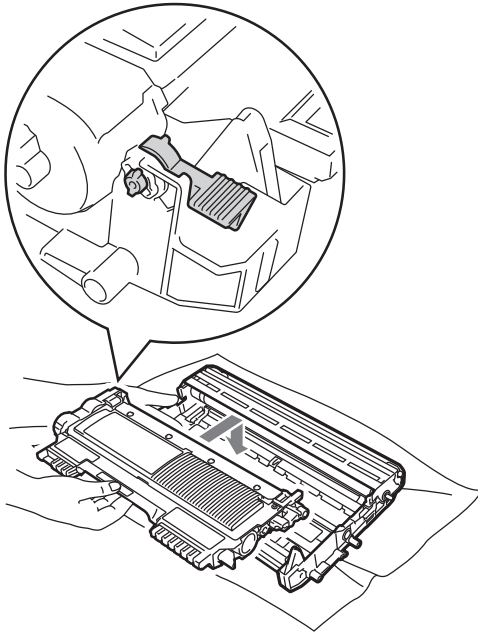
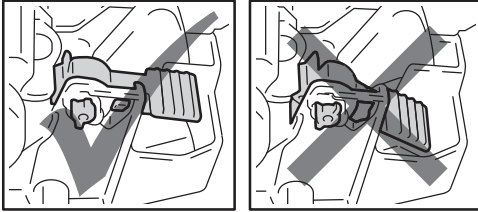

- 8 Put the drum unit and toner cartridge assembly back in the machine.

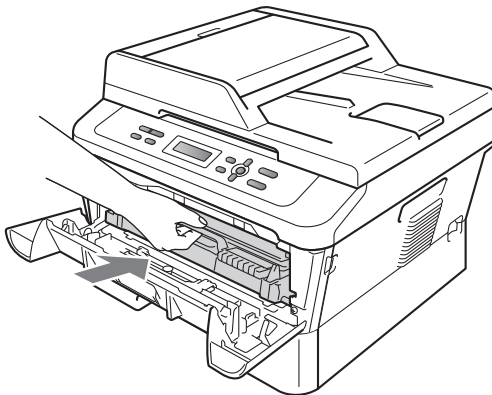

- 9 Close the front cover.

## Cleaning the paper pick-up rollers

If you have paper feed problems, clean the pick-up rollers as follows:

- 1 Turn off the machine. Unplug the power cord from the electrical socket.
- 2 Pull the paper tray completely out of the machine.

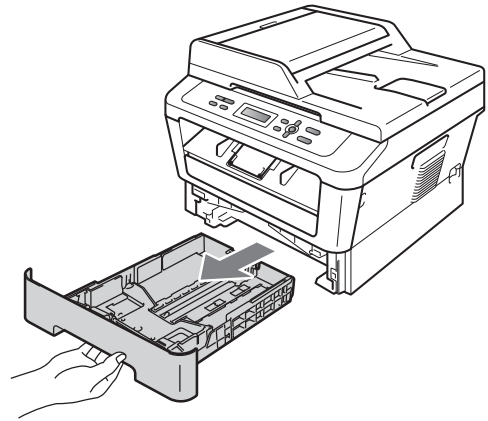

- 3 Tightly wring out a lint-free cloth soaked in lukewarm water, and then wipe the separator pad (1) of the paper tray with it to remove dust.

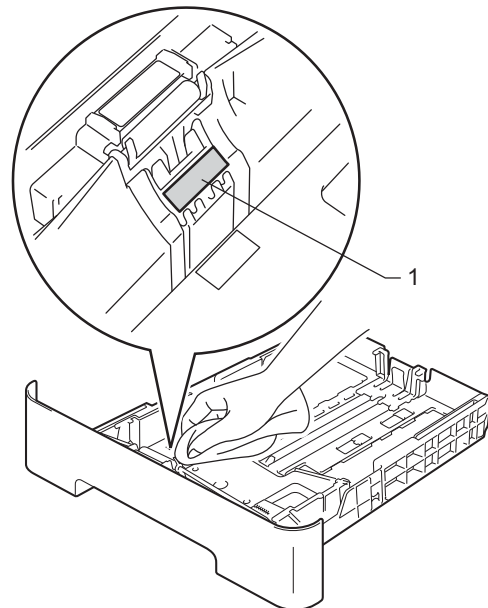



- 4 Wipe the two pick-up rollers (1) inside of the machine to remove dust.

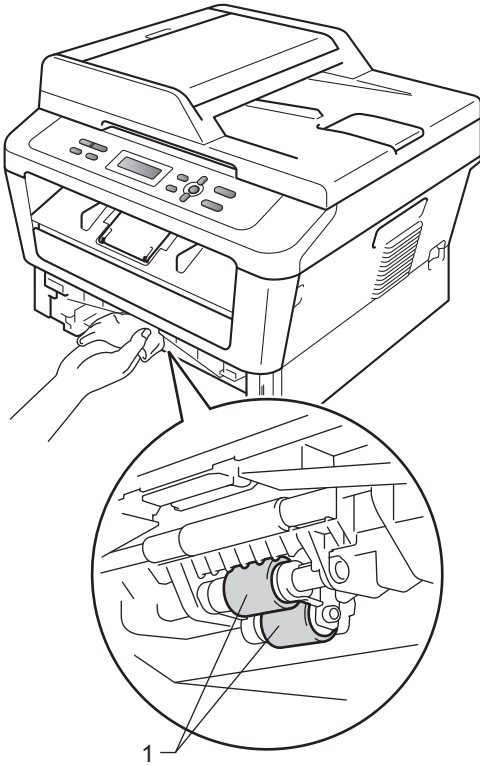

- 5 Put the paper tray back in the machine.
- 6 Plug the machine's power cord back into the electrical socket. Turn on the machine.

# B

# Troubleshooting

## Error and maintenance messages

As with any sophisticated office product, errors may occur and consumable items may need to be replaced. If this happens, your machine identifies the error or required routine maintenance and shows the appropriate message. The most common error and maintenance messages are shown below.

You can clear most errors and perform routine maintenance messages by yourself. If you need more help, the Brother Solutions Center offers the latest FAQs and troubleshooting tips:

Visit us at <http://solutions.brother.com/>.

Error Message	Cause	Action
Cartridge Error	The toner cartridge is not installed correctly.	Pull out the drum unit and remove the toner cartridge, then re-install the toner cartridge in the drum unit.
Cooling Down Wait for a while	The temperature of the drum unit or toner cartridge is too hot. The machine will pause its current print job and go into cooling down mode. During the cooling down mode, you will hear the cooling fan running while the LCD shows <i>Cooling Down, and Wait for a while</i> .	Make sure that you can hear the fan in the machine spinning and that the exhaust outlet is not blocked by something.  If the fan is spinning, remove any obstacles that surround the exhaust outlet, and then leave the machine turned on but do not use it for several minutes.  If the fan is not spinning, disconnect the machine from the power for several minutes then reconnect it.
Cover is Open	The front cover is not completely closed.	Close the front cover of the machine.
Cover is Open (For DCP-7065DN)	The ADF cover is not completely closed.	Close the ADF cover of the machine.
	The ADF is open while loading a document.	Close the ADF cover of the machine, then press <b>Stop/Exit</b> .
Cover is Open	The fuser cover is not completely closed or paper was jammed in the back of the machine when you turned on the power.	<ul style="list-style-type: none"> <li>■ Close the fuser cover of the machine.</li> <li>■ Make sure paper is not jammed inside the back of the machine, and then close the fuser cover and press <b>Start</b>.</li> </ul>
Document Jam (For DCP-7065DN)	The document was not inserted or fed correctly, or the document scanned from the ADF was too long.	See <i>Document is jammed in the top of the ADF unit (For DCP-7065DN)</i> on page 57 or <i>Using the automatic document feeder (ADF) (For DCP-7065DN)</i> on page 21.
Drum Error	The corona wire on the drum unit needs to be cleaned.	Clean the corona wire on the drum unit. (See <i>Cleaning the corona wire</i> on page 46.)
Drum Stop	It is time to replace the drum unit.	Replace the drum unit. (See <i>Replacing the drum unit</i> on page 39.)

Error Message	Cause	Action
Duplex Disabled	The duplex tray is removed or is not correctly installed.	Carefully put the duplex tray into the machine until it clicks into place.
	The back of the machine is not closed completely.	Close the back cover of the machine.
EL Error	The machine has a mechanical problem.	Open the front cover and close it again.
Fuser Error	The temperature of the fuser unit does not rise to a specified temperature within the specified time.	Turn the power switch off, wait a few seconds, and then turn it on again. Leave the machine for 15 minutes with the power turned on.
	The fuser unit is too hot.	
Init Unable XX	The machine has a mechanical problem.	<ul style="list-style-type: none"> <li>■ Disconnect the machine from the power for several minutes and then reconnect it.</li> <li>■ If the problem continues, call your Brother dealer.</li> </ul>
Jam Duplex	The paper is jammed in the duplex tray at the back of the machine.	(See <i>Paper is jammed in the Duplex Tray</i> on page 66.)
Jam Inside	The paper is jammed inside the machine.	(See <i>Paper is jammed inside the machine</i> on page 62.)
Jam Rear	The paper is jammed in the back of the machine.	(See <i>Paper is jammed at the back of the machine</i> on page 60.)
Jam Tray	The paper is jammed in the paper tray of the machine.	(See <i>Paper is jammed in the standard paper tray</i> on page 59.)
No Paper	The machine is out of paper or paper is not correctly loaded in the paper tray.	<p>Do one of the following:</p> <ul style="list-style-type: none"> <li>■ Refill the paper in the paper tray and press <b>Start</b>.</li> <li>■ Remove the paper and load it again. Then press <b>Start</b>.</li> <li>■ If the problem is not resolved, the paper pick-up roller may need to be cleaned. Clean the paper pick-up roller. (See <i>Cleaning the paper pick-up rollers</i> on page 52.)</li> </ul>
Manual Feed	Manual feed was selected as the paper source when there was no paper in the manual feed slot.	Place a sheet of paper in the manual feed slot. (See <i>Loading paper in the manual feed slot</i> on page 11.)
No Toner	The toner cartridge is not installed correctly.	Pull out the drum unit. Take out the toner cartridge and then put it back into the drum unit.



Error Message	Cause	Action
Out of Memory	The machine's memory is full.	<p><b>Do one of the following:</b></p> <ul style="list-style-type: none"> <li>■ Press <b>Start</b> to copy the scanned pages. (Copy operation in progress)</li> <li>■ Press <b>Stop/Exit</b> and wait until the other operations in progress finish, and then try again.</li> <li>■ Reduce print resolution. (See the <i>Basic tab in the Software User's Guide.</i>)</li> </ul>
Print Unable XX	The machine has a mechanical problem.	<p>Do one of the following:</p> <ul style="list-style-type: none"> <li>■ Disconnect the machine from the AC power outlet for several minutes, then reconnect it.</li> <li>■ If the problem continues, call your Brother dealer.</li> </ul>
Replace Drum	It is time to replace the drum unit.	<p>Replace the drum unit. (See <i>Replacing the drum unit</i> on page 39.)</p>
	The drum unit counter was not reset when a new drum was installed.	<p>Reset the drum unit counter. (See <i>Resetting the drum counter</i> on page 43.)</p>
Replace Toner	The machine will stop printing until you replace the toner cartridge.	<p>If you have set the Toner setting to <b>Stop</b>, replace the toner cartridge with a new and unused original Brother toner cartridge. This will reset the Replace Toner mode. (See <i>Replacing the toner cartridge</i> on page 33.)</p> <p>If you have set the Toner setting to <b>Continue</b>, the machine will continue to print data until the LCD shows <b>Toner Ended</b>. For how to operate the machine in Continue mode, see <i>Toner Settings</i> in <i>Chapter 1 of the Advanced User's Guide</i>.</p>
Size Error DX	The paper in the tray is not a suitable size for automatic duplex printing.	<p>Load A4 paper for automatic duplex printing, and then press <b>Start</b>. (See <i>Print media</i> on page 102.)</p>
Toner Ended	It is time to replace the toner cartridge.	<p>Replace the toner cartridge with a new one. (See <i>Replacing the toner cartridge</i> on page 33.)</p>
Toner Low	You will need to replace the toner cartridge soon.	<p>Buy a new toner cartridge before you get a <b>Replace Toner</b> message.</p>

## Document Jams

### Document is jammed in the top of the ADF unit (For DCP-7065DN)

- 1 Take out any paper from the ADF that is not jammed.
- 2 Open the ADF cover.
- 3 Pull the jammed document out to the left.

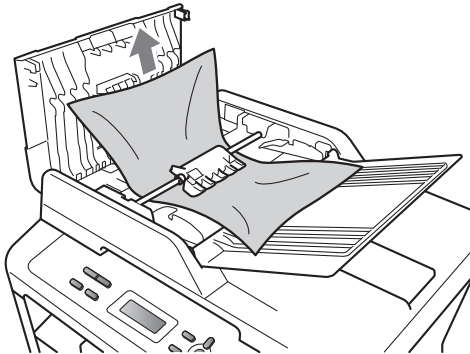

- 4 Close the ADF cover.
- 5 Press **Stop/Exit**.

### Document is jammed under the document cover (For DCP-7065DN)

- 1 Take out any paper from the ADF that is not jammed.
- 2 Lift the document cover.
- 3 Pull the jammed document out to the right.

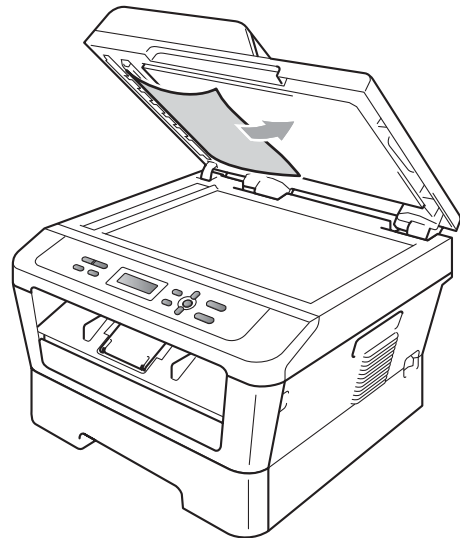

- 4 Close the document cover.
- 5 Press **Stop/Exit**.

## Removing small documents jammed in the ADF (For DCP-7065DN)

- 1 Lift the document cover.
- 2 Insert a piece of stiff paper, such as cardstock, into the ADF to push any small paper scraps through.

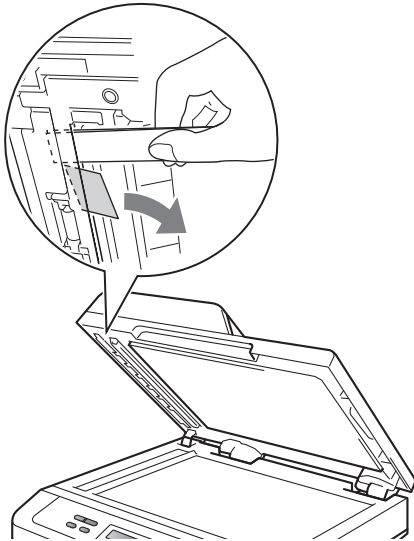

- 3 Close the document cover.
- 4 Press **Stop/Exit**.

## Document is jammed at the output tray (For DCP-7065DN)

- 1 Take out any paper from the ADF that is not jammed.
- 2 Pull the jammed document out to the right.

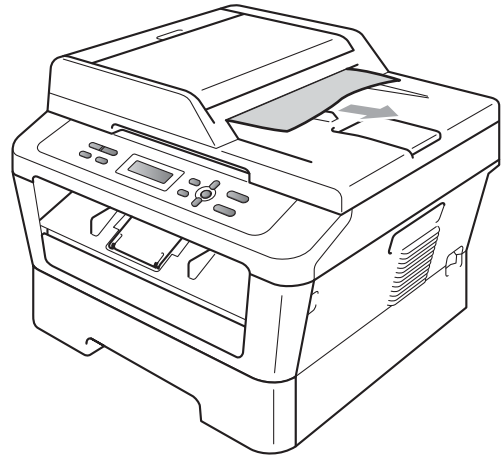

- 3 Press **Stop/Exit**.

# Paper Jams

## Paper is jammed in the standard paper tray

If the LCD shows Jam Tray, follow these steps:

- 1 Pull the paper tray completely out of the machine.

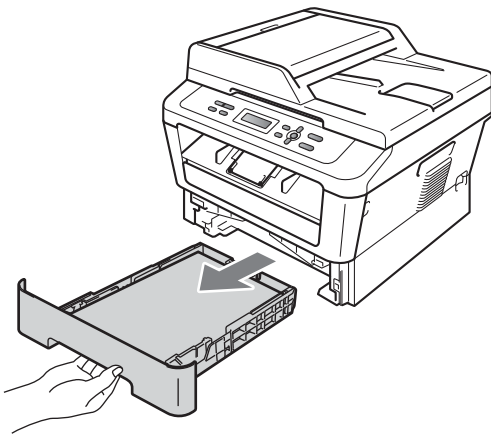

- 2 Use both hands to slowly pull out the jammed paper.

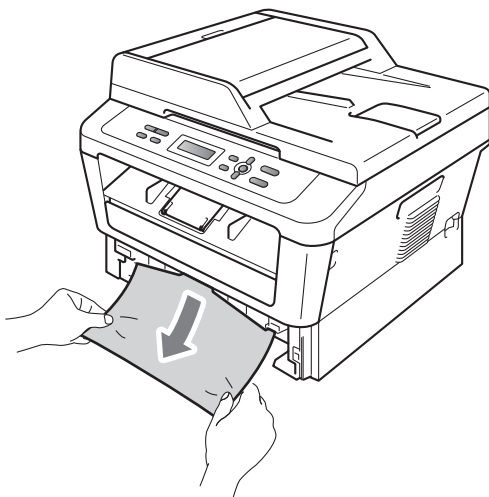

### ! IMPORTANT

If the paper cannot easily be removed in this direction, stop and follow the instructions for *Paper is jammed inside the machine* on page 62.

### Note

Pulling out the jammed paper downwards allows you to remove the paper more easily.

- 3 Make sure the paper is below the maximum paper mark (▼▼▼) (1) of the paper tray. While pressing the green paper-guide release lever, slide the paper guides to fit the paper size. Make sure that the guides are firmly in the slots. (See *Loading paper in the standard paper tray* on page 9.)

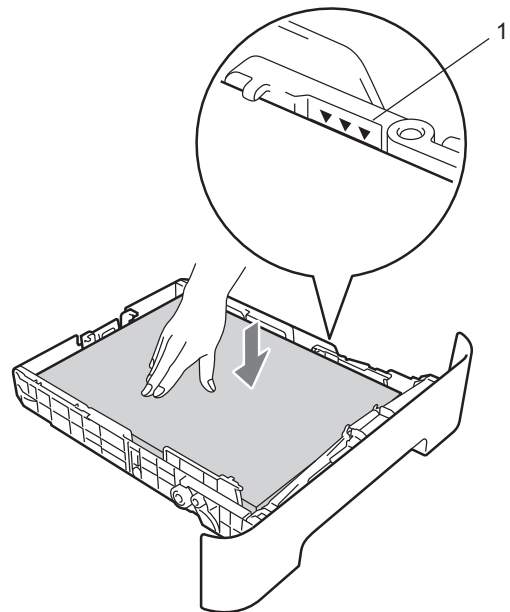

- 4 Put the paper tray firmly back in the machine.

B

## Paper is jammed at the back of the machine

If the LCD shows **Jam Rear**, a paper jam occurred behind the back cover. Follow these steps:

- 1 Open the front cover. Leave the machine turned on for 10 minutes to cool down.

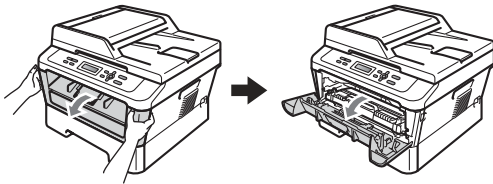

### WARNING

#### HOT SURFACE

After you have just used the machine, some internal parts of the machine will be extremely hot. When you open the front or back cover (back output tray) of the machine, **DO NOT** touch the shaded parts shown in the illustration. If you do this, you may burn yourself.

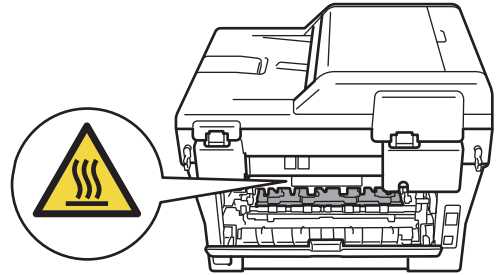
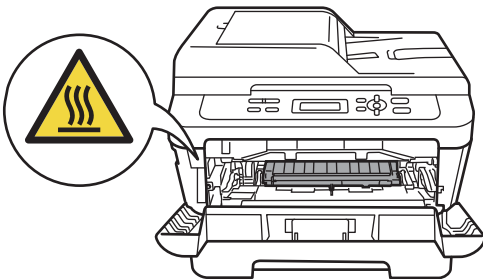

- 2 Slowly take out the drum unit and toner cartridge assembly.

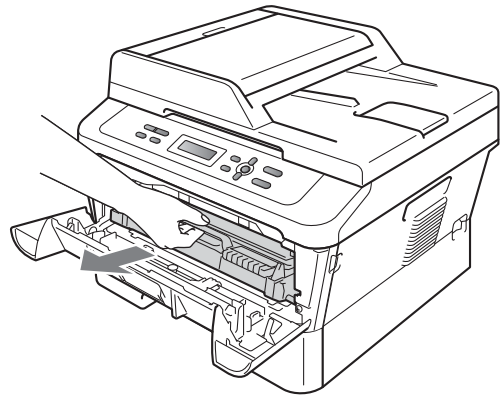



**! IMPORTANT**

- We recommend that you place the drum unit and the toner cartridges on a clean, flat surface with a sheet of disposable paper or cloth underneath it in case you accidentally spill or scatter toner.
- To prevent damage to the machine caused by static electricity, **DO NOT** touch the electrodes shown in the illustration.

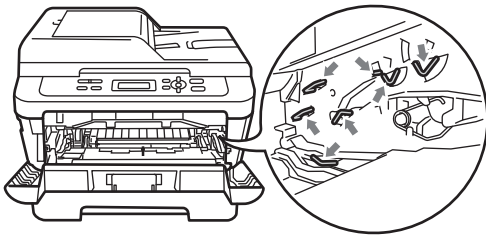

- 3** Open the back cover (face-up output tray).

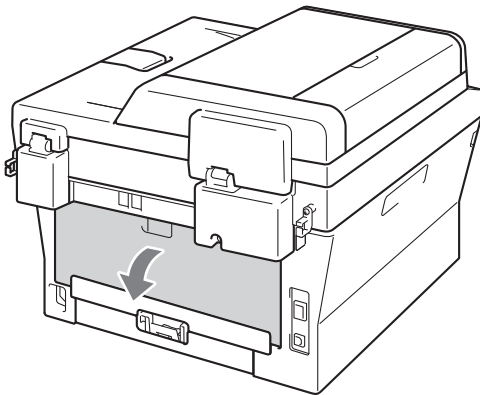

- 4** Pull down the tabs at the left and right hand sides to open the fuser cover (1).

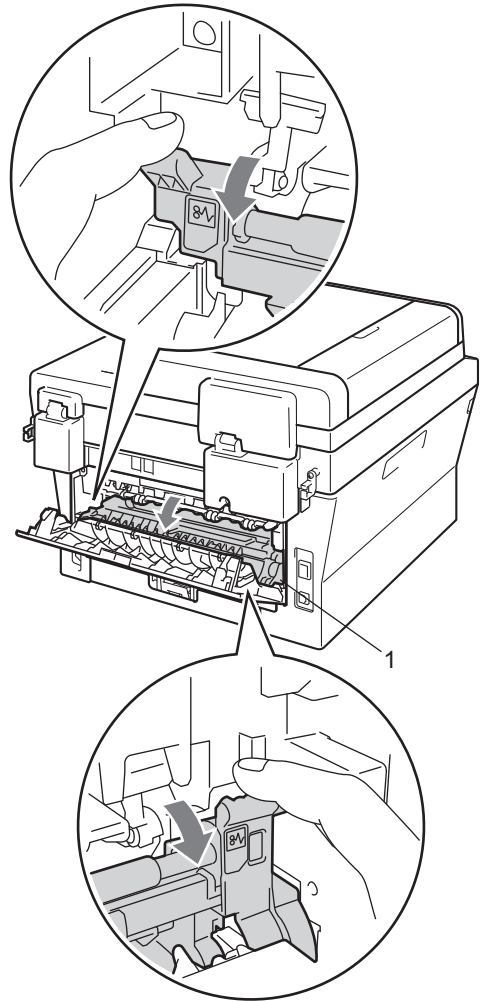

- 5 Using both hands, gently pull the jammed paper out of the fuser unit.

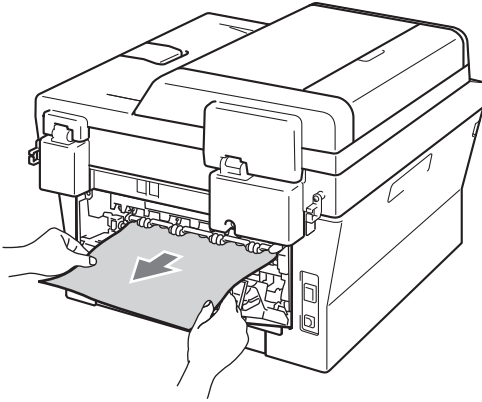

- 6 Close the fuser cover and the back cover (face-up output tray).

- 7 Put the drum unit and toner cartridge assembly back into the machine.

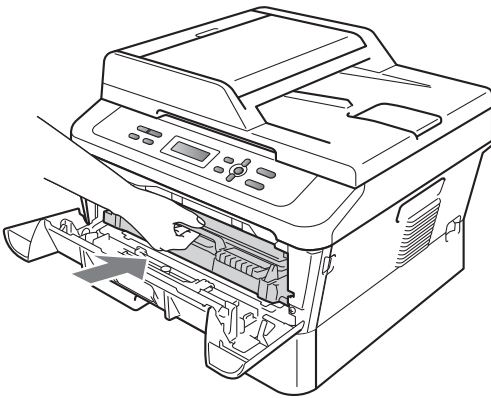

- 8 Close the front cover. If the machine does not start printing automatically, press **Start**.

## Paper is jammed inside the machine

If the LCD shows *Jam Inside*, follow these steps:

- 1 Leave the machine turned on for 10 minutes to cool down.
- 2 Open the front cover.

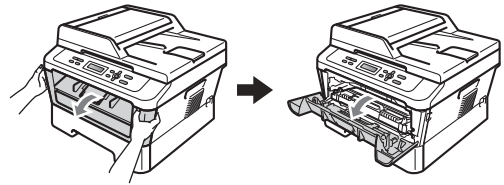

### ⚠ WARNING

#### 🔥 HOT SURFACE

After you have just used the machine, some internal parts of the machine will be extremely hot. When you open the front or back cover (back output tray) of the machine, **DO NOT** touch the shaded parts shown in the illustration. If you do this, you may burn yourself.

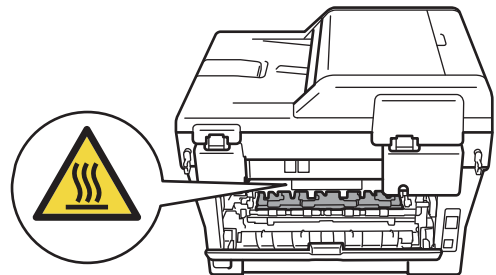
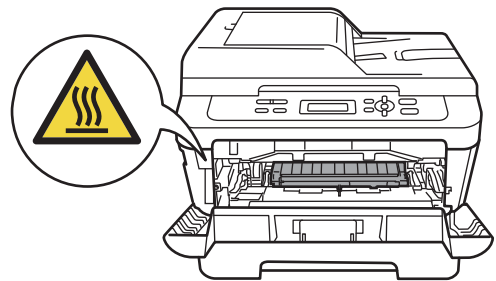

- 3 Slowly take out the drum unit and toner cartridge assembly. The jammed paper may be pulled out with the drum unit and toner cartridge assembly, or this may release the paper so you can pull it out of the inside of the machine.

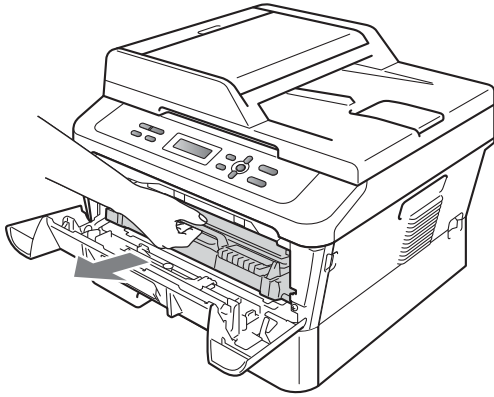

If you cannot remove the drum unit and toner cartridge assembly easily, do not use extra force. Instead, go to step 7.

### ! IMPORTANT

- We recommend that you put the drum unit and toner cartridge assembly on a piece of disposable paper or cloth in case you accidentally spill or scatter toner.
- To prevent damage to the machine from static electricity, DO NOT touch the electrodes shown in the illustration.

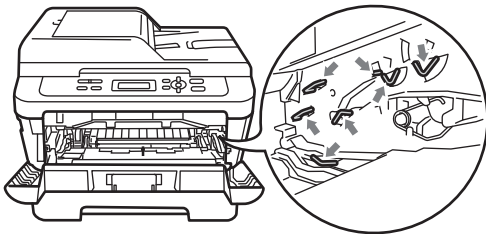

- 4 Push down the green lock lever and take the toner cartridge out of the drum unit. Clear the jammed paper if there is any inside the drum unit.

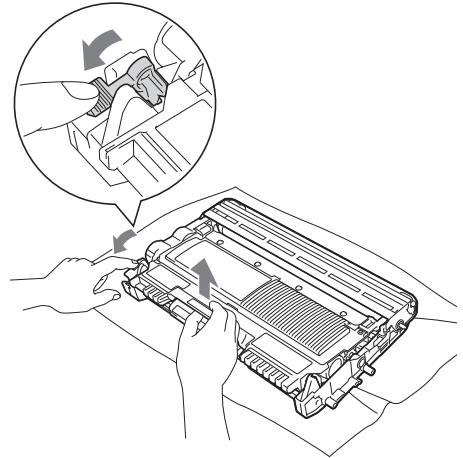

### ! IMPORTANT

- Handle the toner cartridge carefully. If toner scatters on your hands or clothes, immediately wipe or wash it off with cold water.
- To avoid print quality problems, DO NOT touch the shaded parts shown in the illustrations.

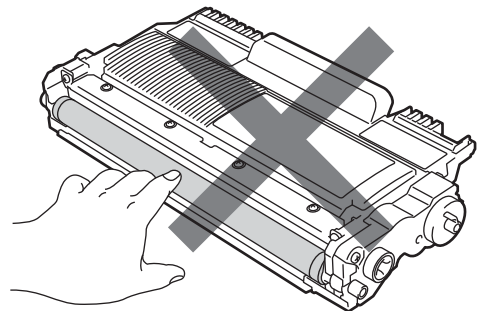

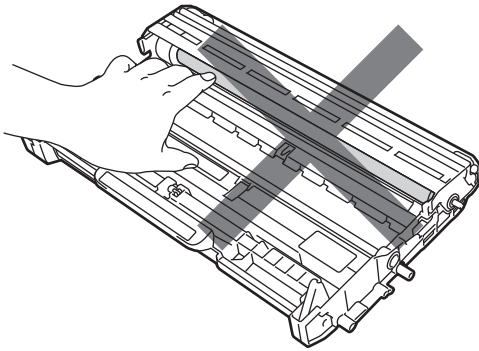

- 5 Put the toner cartridge back into the drum unit until you hear it lock into place. If you put the cartridge in correctly, the green lock lever will lift automatically.

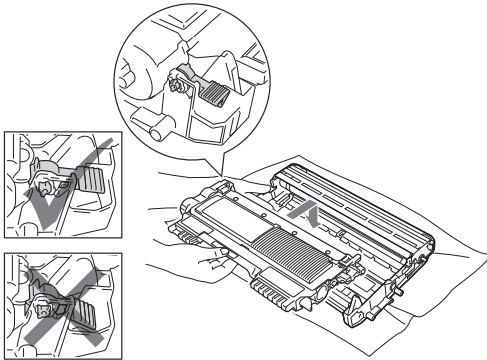

- 6 If you were able to remove the drum unit and toner cartridge assembly and the jammed paper, you have cleared the paper jam. Put the drum unit and toner cartridge assembly back into the machine and close the front cover. If the machine does not start printing automatically, press **Start**.

- 7 Lift the scanner cover.

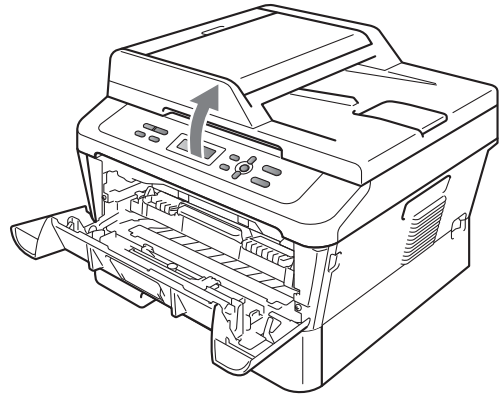

Use both hands to carefully pull the jammed paper up and out of the output tray opening.

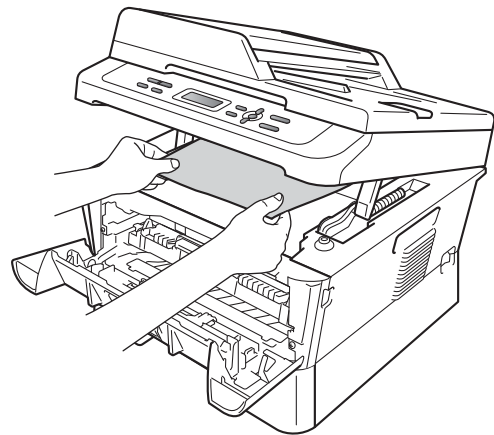

- 8 Close the scanner cover.

- 9 If you could not pull the jammed paper out of the output tray opening as shown in step 7, take the paper tray completely out of the machine.

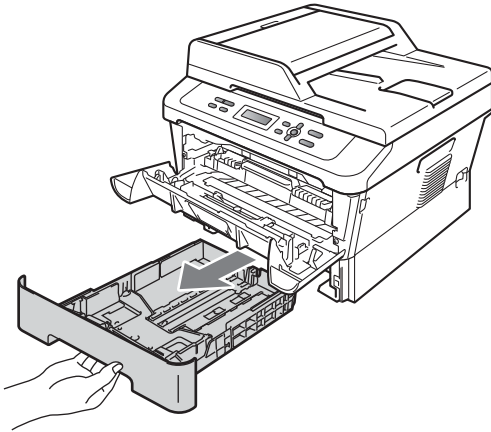

- 10 Pull the jammed paper out of the paper tray opening.

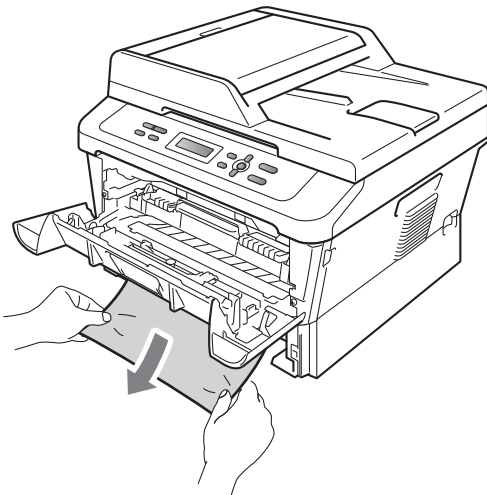

- 11 Put the paper tray back into the machine. If you have removed the jammed paper, you have cleared the paper jam.



**Note**

- If the LCD shows a `Jam Inside` message, check if there is a torn piece of paper inside the machine and drum unit by following the instructions in steps 3 to 6.
- If you turn off the machine while the LCD shows a `Jam Inside` message, the machine will print incomplete data from your computer.

## Paper is jammed in the Duplex Tray

If the LCD shows `Jam Duplex`, follow these steps:

- 1 Leave the machine turned on for 10 minutes to cool down.

### WARNING

#### HOT SURFACE

After you have just used the machine, some internal parts of the machine will be extremely hot. When you open the front or back cover (back output tray) of the machine, DO NOT touch the shaded parts shown in the illustration. If you do this, you may burn yourself.

- 2 Pull the duplex tray completely out of the machine.

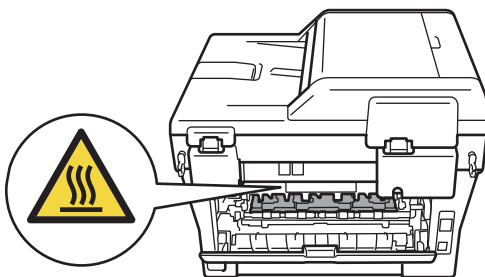
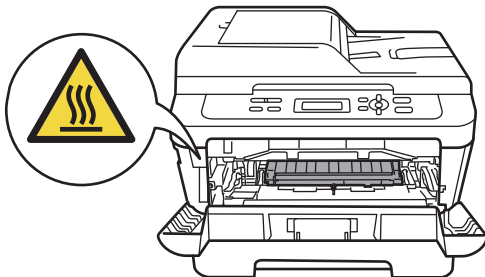
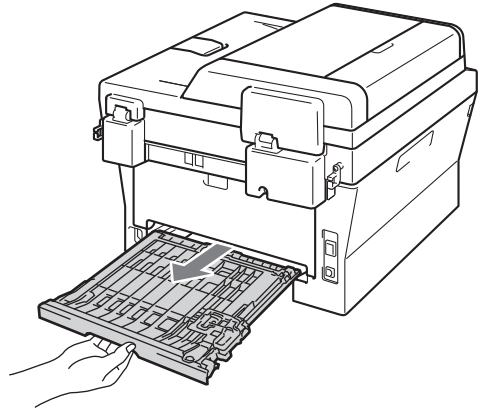

- 3 Pull the jammed paper out of the machine or the duplex tray.

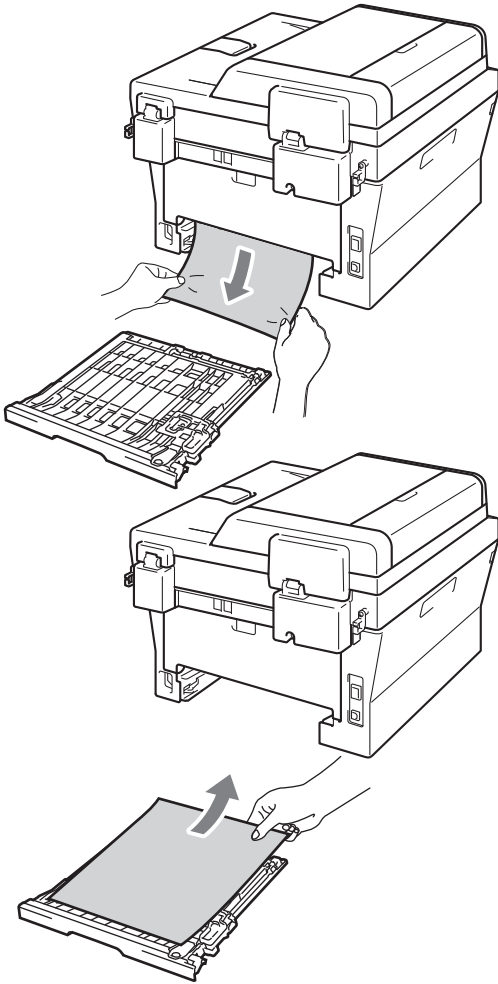

- 4 Make sure that no paper remains under the machine.

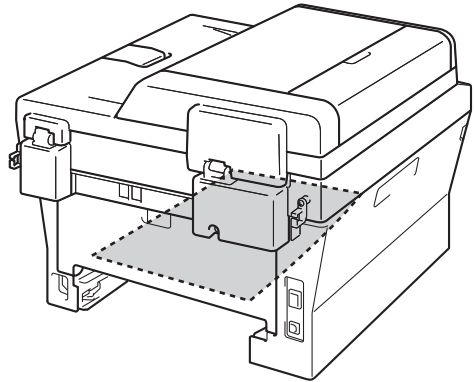

- 5 Put the duplex tray back in the machine.

# If you are having difficulty with your machine

If you think there is a problem with your machine, check the chart below and follow the troubleshooting tips.

Most problems can be easily resolved by yourself. If you need additional help, the Brother Solutions Center offers the latest FAQs and troubleshooting tips.

Visit us at <http://solutions.brother.com/>.

Check the chart below and follow the troubleshooting tips.

## Copy difficulties

Difficulties	Suggestions
Vertical black line appears in copies.	Black vertical lines on copies are typically caused by dirt or correction fluid on the glass strip, or the corona wire is dirty. (See <i>Cleaning the scanner glass</i> on page 45 and <i>Cleaning the corona wire</i> on page 46.)
Copies are blank.	Make sure you are loading the document correctly. (See <i>Using the automatic document feeder (ADF) (For DCP-7065DN)</i> on page 21 or <i>Using the scanner glass</i> on page 22.)

## Printing difficulties

Difficulties	Suggestions
Poor print quality	See <i>Improving the print quality</i> on page 73.
No printout.	<ul style="list-style-type: none"><li>■ Check that the machine is plugged in and the power switch is turned on.</li><li>■ Check that the toner cartridge and drum unit are installed correctly. (See <i>Replacing the drum unit</i> on page 39.)</li><li>■ Check the interface cable connection on both the machine and your computer. (See the <i>Quick Setup Guide</i>.)</li><li>■ Check that the correct printer driver has been installed and chosen.</li><li>■ Check to see if the LCD is showing an error message. (See <i>Error and maintenance messages</i> on page 54.)</li><li>■ Check the machine is online: (Windows® 7 and Windows Server® 2008 R2) Click the <b>Start</b> button and <b>Devices and Printers</b>. Right-click <b>Brother DCP-XXXX Printer</b>. Make sure that <b>Use Printer Offline</b> is unchecked. (Windows Vista®) Click the <b>Start</b> button, <b>Control Panel</b>, <b>Hardware and Sound</b>, and then <b>Printers</b>. Right-click <b>Brother DCP-XXXX Printer</b>. Make sure that <b>Use Printer Offline</b> is unchecked. (Windows® XP and Windows Server® 2003/2008) Click the <b>Start</b> button and choose <b>Printers and Faxes</b>. Right-click <b>Brother DCP-XXXX Printer</b>. Make sure that <b>Use Printer Offline</b> is unchecked. (Windows® 2000) Click the <b>Start</b> button and choose <b>Settings</b> and then <b>Printers</b>. Right-click <b>Brother DCP-XXXX Printer</b>. Make sure that <b>Use Printer Offline</b> is unchecked.</li></ul>



## Printing difficulties (continued)

Difficulties	Suggestions
The machine prints unexpectedly or it prints garbage.	<ul style="list-style-type: none"> <li>■ Press <b>Job Cancel</b> to cancel print jobs.</li> <li>■ Check the settings in your application to make sure it is set up to work with your machine.</li> <li>■ Pull out the paper tray and wait until the machine stops printing. Then turn off the machine's power switch and disconnect from the power for several minutes.</li> </ul>
The machine prints the first couple of pages correctly, then some pages have text missing.	<ul style="list-style-type: none"> <li>■ Check the settings in your application to make sure that it is set up to work with your machine.</li> <li>■ Your computer is not recognising the machine's input buffer's full signal. Make sure that you connected the interface cable correctly. (See the <i>Quick Setup Guide</i>.)</li> </ul>
The headers or footers appear when the document displays on the screen but they do not show up when it is printed.	There is an unprintable area on the top and bottom of the page. Adjust the top and bottom margins in your document to allow for this. (See <i>Unscannable and unprintable areas</i> on page 15.)
The machine does not print on both sides of the paper even though the printer driver setting is Duplex.	Check the paper size setting in the printer driver. You need to choose A4 [60 to 105 g/m <sup>2</sup> ].
The machine is not printing or has stopped printing.	<p>Press <b>Job Cancel</b>.</p> <p>As the machine cancels the job and clears it from the memory it may produce an incomplete printout.</p>

## Scanning difficulties

Difficulties	Suggestions
TWAIN errors appear while scanning.	Make sure that the Brother TWAIN driver is chosen as the primary source. In PaperPort™ 12SE, click <b>File, Scan or Get Photo</b> and choose the Brother TWAIN driver.
OCR does not work.	<p>Try increasing the scanning resolution.</p> <p>(Macintosh users)            Presto! PageManager must be downloaded and installed before use. See <i>Accessing Brother Support (Macintosh)</i> on page 5 for further instructions.</p>
(For DCP-7055W / DCP-7057W / DCP-7065DN / DCP-7070DW) Network scanning does not work.	See <i>Network difficulties (For DCP-7055W / DCP-7057W / DCP-7065DN / DCP-7070DW)</i> on page 71.

## Software difficulties

Difficulties	Suggestions
Cannot install software or print.	Run the <b>Repair MFL-Pro Suite</b> program on the CD-ROM. This program will repair and reinstall the software.
Cannot perform '2 in 1' or '4 in 1' printing.	Check that the paper size setting in the application and in the printer driver are the same.
The machine does not print from Adobe® Illustrator®.	Try to reduce the print resolution. (See <i>Advanced tab</i> in the <i>Software User's Guide</i> .)



## Paper handling difficulties

Difficulties	Suggestions
The machine does not feed paper. The LCD shows <i>No Paper</i> or a <i>Paper Jam</i> message.	<ul style="list-style-type: none"> <li>■ If there is no paper, load a new stack of paper into the paper tray.</li> <li>■ If there is paper in the paper tray, make sure it is straight. If the paper is curled, you should straighten it. Sometimes it is helpful to remove the paper, turn the stack over and put it back into the paper tray.</li> <li>■ Reduce the amount of paper in the paper tray, and then try again.</li> <li>■ Make sure that manual feed mode is not chosen in the printer driver.</li> <li>■ Clean the paper pick-up roller. See <i>Cleaning the paper pick-up rollers</i> on page 52.</li> <li>■ If the LCD shows the <i>Paper Jam</i> message and you still have a problem, see <i>Error and maintenance messages</i> on page 54.</li> </ul>
How do I print on envelopes?	You can load envelopes from the manual feed slot. Your application must be set up to print the envelope size you are using. This is usually done in the <i>Page Setup</i> or <i>Document Setup</i> menu of your application.
What paper can I use?	You can use thin paper, plain paper, thick paper, bond paper, recycled paper, envelopes and labels that are made for laser machines. (For details, see <i>Acceptable paper and other print media</i> on page 17.) <ul style="list-style-type: none"> <li>■ You can load envelopes from the manual feed slot.</li> </ul>
There is a paper jam.	Clear the jammed paper. (See <i>Document Jams</i> on page 57.)

## Print quality difficulties

Difficulties	Suggestions
Printed pages are curled.	<ul style="list-style-type: none"> <li>■ Low quality thin or thick paper or not printing on the recommended side of the paper could cause this problem. Try turning over the stack of paper in the paper tray.</li> <li>■ Make sure that you choose the <i>Paper Type</i> that suits the print media type you are using. (See <i>Acceptable paper and other print media</i> on page 17.)</li> </ul>
Printed pages are smeared.	The <i>Paper Type</i> setting may be incorrect for the type of print media you are using, or the print media may be too thick or have a rough surface. (See <i>Acceptable paper and other print media</i> on page 17 and <i>Basic tab</i> in the <i>Software User's Guide</i> .)
Printouts are too light.	<ul style="list-style-type: none"> <li>■ If this problem occurs when making copies or printing, set <i>Toner Save</i> mode to <math>\odot</math> in the machine menu settings. (See <i>Toner Save</i> in <i>Chapter 1</i> of the <i>Advanced User's Guide</i>.)</li> <li>■ Set <i>Toner Save</i> mode to <b>Off</b> in the <b>Advanced</b> tab in the printer driver. (See <i>Advanced tab</i> in the <i>Software User's Guide</i>.)</li> </ul>

**Network difficulties (For DCP-7055W / DCP-7057W / DCP-7065DN / DCP-7070DW)**

Difficulties	Suggestions
Cannot print over a wired Network.	<p>If you are having Network problems see the <i>Network User's Guide</i> for more information.</p> <p>Make sure your machine is powered on, is on-line and is in the Ready mode. Print the Network Configuration list to see your current Network settings. (See <i>Network Configuration List</i> in <i>Chapter 1</i> of the <i>Advanced User's Guide</i>.) Reconnect the LAN cable to the hub to verify that the cable and network connections are good. If possible, try connecting the machine to a different port on your hub using a different cable. You can check the current wired network status from the Network control panel menu.</p>
The network scanning feature does not work.	<p><b>(Windows®)</b></p> <p>It is necessary to set the third-party Security/Firewall Software to allow Network scanning. To add port 54925 for Network scanning, enter the information below:</p> <ul style="list-style-type: none"> <li>■ In Name: Enter any description, for example Brother NetScan.</li> <li>■ In Port number: Enter 54925.</li> <li>■ In Protocol: UDP is selected.</li> </ul> <p>Please refer to the instruction manual that came with your third-party Security/Firewall Software or contact the software manufacturer.</p> <p>For more details, you can read FAQs and troubleshooting suggestions at <a href="http://solutions.brother.com/">http://solutions.brother.com/</a>.</p> <p><b>(Macintosh)</b></p> <ul style="list-style-type: none"> <li>■ The network scanning feature may be unable due to the firewall settings. Change or disable the firewall settings. If you are using a third-party personal Firewall software, see the User's Guide for your software or contact the software manufacturer.</li> <li>■ Re-select your machine in the <b>Device Selector</b> application located in <b>Macintosh HD/Library/Printers/Brother/Utilities/Device Selector</b> or from the model list in <b>ControlCenter2</b>.</li> </ul>
Your computer cannot find your machine.	<p><b>(Windows®)</b> The firewall setting on your PC may be rejecting the necessary network connection. (For details, see the instructions above.)</p> <p><b>(Macintosh)</b></p> <ul style="list-style-type: none"> <li>■ The computer may be unable to detect the machine due to the firewall settings. Change or disable the firewall settings. If you are using a third-party personal Firewall software, see the User's Guide for your software or contact the software manufacturer.</li> <li>■ Re-select your machine in the <b>Device Selector</b> application located in <b>Macintosh HD/Library/Printers/Brother/Utilities/Device Selector</b> or from the model list in <b>ControlCenter2</b>.</li> </ul>
Cannot connect to wireless network. (For DCP-7055W / DCP-7057W / DCP-7070DW)	<p>Investigate the problem using the <b>WLAN Report</b>. Press <b>Menu</b>, press <b>▲</b> or <b>▼</b> to choose <b>5.Machine Info.</b> (For DCP-7070DW) <b>4.Machine Info.</b> (For DCP-7055W / DCP-7057W) and press <b>OK</b>, press <b>▲</b> or <b>▼</b> to choose <b>5.WLAN Report</b> and press <b>OK</b>, and then press <b>Start</b>. For more details, see <i>Quick Setup Guide</i>.</p>



## Other

Difficulties	Suggestions
The machine will not turn on.	<p>Adverse conditions on the power connection (such as lightning or a power surge) may have triggered the machine's internal safety mechanisms. Turn the machine off and unplug the power cord. Wait for ten minutes, then plug in the power cord and turn the machine on.</p> <p>If the problem is not solved, turn off the machine. Plug the power cord into a different known working outlet and turn on the machine.</p>

# Improving the print quality

If you have a print quality problem, make a copy first (put a document on the scanner glass and press **Start**). If the printout looks good, the problem is probably not the machine. Check the interface cable connections or try printing a different document. If the printout or test page printed from the machine has a quality problem, check the following steps first. And then, if you still have a print quality problem, check the chart below and follow the recommendations.





## Note



Brother does not recommend the use of cartridges other than Brother Original cartridges or the refilling of used cartridges with toner from other sources.

- 1 To get the best print quality, we suggest using the recommended paper. Check that you use paper that meets our specifications. (See *Acceptable paper and other print media* on page 17.)
- 2 Check that the drum unit and toner cartridge assembly is installed correctly.

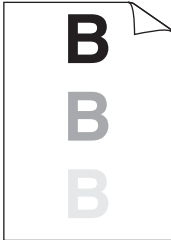
Examples of poor print quality	Recommendation
<div style="text-align: center;">  <p><b>Faint</b></p> </div>	<ul style="list-style-type: none"> <li>■ Take out the drum unit and toner cartridge assembly. Hold the assembly level with both hands and gently shake it from side to side several times to spread the toner evenly inside the cartridge.</li> <li>■ Check if the Toner Setting in <i>Replace Toner</i> is set to <i>Continue</i> (Continue mode). See <i>Toner settings</i> in <i>Chapter 1</i> of the <i>Advanced User's Guide</i>.</li> <li>■ Check the machine's environment. Conditions such as humidity, high temperatures, and so on, may cause this print fault. See the <i>Safety and Legal booklet</i>.</li> <li>■ If the whole page is too light, Toner Save mode may be on. Turn off <i>Toner Save</i> mode in the machine menu settings or <b>Toner Save</b> mode in the printer <b>Properties</b> of the driver. See <i>Toner save</i> in <i>Chapter 1</i> of the <i>Advanced User's Guide</i> or <i>Advanced tab</i> in <i>Chapter 2</i> of the <i>Software User's Guide</i>.</li> <li>■ Clean the corona wire of the drum unit. See <i>Cleaning the corona wire</i> on page 46.</li> <li>■ Put in a new toner cartridge. See <i>Replacing the toner cartridge</i> on page 33.</li> <li>■ Put in a new drum unit. See <i>Replacing the drum unit</i> on page 39.</li> </ul>



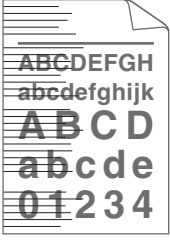

Examples of poor print quality	Recommendation
 <p data-bbox="198 560 397 589"><b>Grey background</b></p>	<ul style="list-style-type: none"> <li>■ Make sure that you use paper that meets our specifications. See <i>Acceptable paper and other print media</i> on page 17.</li> <li>■ Check the machine's environment. Conditions such as high temperatures and high humidity can increase the amount of background shading. See the <i>Safety and Legal booklet</i>.</li> <li>■ Put in a new toner cartridge. See <i>Replacing the toner cartridge</i> on page 33.</li> <li>■ Put in a new drum unit. See <i>Replacing the drum unit</i> on page 39.</li> </ul>
 <p data-bbox="260 898 336 927"><b>Ghost</b></p>	<ul style="list-style-type: none"> <li>■ Make sure that you use paper that meets our specifications. Rough-surfaced paper or thick print media may cause this problem. See <i>Acceptable paper and other print media</i> on page 17.</li> <li>■ Make sure that you choose the correct media type in the printer driver or in the machine's Paper Type menu setting. See <i>Acceptable paper and other print media</i> on page 17 and <i>Basic tab</i> in <i>Chapter 2</i> of the <i>Software User's Guide</i>.</li> <li>■ Choose <b>Reduce Ghosting</b> mode in the printer driver. See <i>Ghost Reduction Setting</i> in <i>Chapter 2</i> (for Windows®) or <i>Chapter 8</i> (for Macintosh) of the <i>Software User's Guide</i>.</li> <li>■ Put in a new toner cartridge. See <i>Replacing the toner cartridge</i> on page 33.</li> <li>■ Put in a new drum unit. See <i>Replacing the drum unit</i> on page 39.</li> <li>■ The fuser unit may be contaminated. Call your Brother dealer.</li> </ul>
 <p data-bbox="219 1420 377 1449"><b>Toner specks</b></p>	<ul style="list-style-type: none"> <li>■ Make sure that you use paper that meets our specifications. Rough-surfaced paper may cause the problem. See <i>Acceptable paper and other print media</i> on page 17.</li> <li>■ Clean the corona wire and the drum unit. See <i>Cleaning the corona wire</i> on page 46 and <i>Cleaning the drum unit</i> on page 48.</li> <li>■ The drum unit may be damaged. Put in a new drum unit. See <i>Replacing the drum unit</i> on page 39.</li> <li>■ The fuser unit may be contaminated. Call your Brother dealer.</li> </ul>

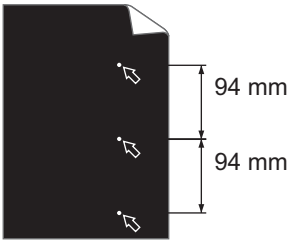
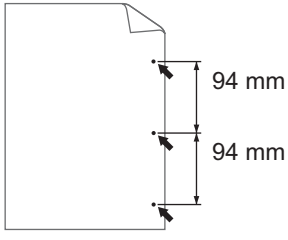
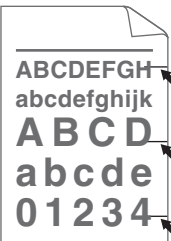
Examples of poor print quality	Recommendation
 <p data-bbox="257 562 399 587"><b>Hollow print</b></p>	<ul style="list-style-type: none"> <li data-bbox="546 266 1252 320">■ Make sure that you use paper that meets our specifications. See <i>Acceptable paper and other print media</i> on page 17.</li> <li data-bbox="546 340 1252 450">■ Choose <b>Thick Paper</b> mode in the printer driver, choose <b>Thick</b> in the machine's Paper Type menu setting or use thinner paper than you are currently using. See <i>Paper Type</i> on page 16 and <i>Basic tab</i> in the <i>Software User's Guide</i>.</li> <li data-bbox="546 469 1252 552">■ Check the machine's environment. Conditions such as high humidity can cause hollow print. See the <i>Safety and Legal booklet</i>.</li> <li data-bbox="546 571 1252 625">■ The drum unit may be damaged. Put in a new drum unit. See <i>Replacing the drum unit</i> on page 39.</li> </ul>
 <p data-bbox="278 933 378 958"><b>All black</b></p>	<ul style="list-style-type: none"> <li data-bbox="546 637 1252 747">■ Clean the corona wire inside the drum unit by sliding the green tab from left to right and right to left several times. Be sure to return the green tab to the home position (▲). See <i>Cleaning the corona wire</i> on page 46.</li> <li data-bbox="546 767 1252 821">■ The drum unit may be damaged. Put in a new drum unit. See <i>Replacing the drum unit</i> on page 39.</li> <li data-bbox="546 840 1252 865">■ The fuser unit may be contaminated. Call your Brother dealer.</li> </ul>
 <p data-bbox="168 1271 488 1296"><b>White lines across the page</b></p>	<ul style="list-style-type: none"> <li data-bbox="546 975 1252 1029">■ Make sure that you use paper that meets our specifications. A rough surfaced paper or thick print media can cause problems.</li> <li data-bbox="546 1049 1252 1159">■ Make sure that you choose the appropriate media type in the printer driver or in the machine's Paper Type menu setting. See <i>Acceptable paper and other print media</i> on page 17 and <i>Basic tab</i> in the <i>Software User's Guide</i>.</li> <li data-bbox="546 1178 1252 1261">■ The problem may disappear by itself. Print multiple pages to clear this problem, especially if the machine has not been used for a long time.</li> <li data-bbox="546 1280 1252 1335">■ The drum unit may be damaged. Put in a new drum unit. See <i>Replacing the drum unit</i> on page 39.</li> </ul>
 <p data-bbox="203 1638 454 1663"><b>Lines across the page</b></p>	<ul style="list-style-type: none"> <li data-bbox="546 1346 1252 1400">■ Clean the corona wire of the drum unit. See <i>Cleaning the corona wire</i> on page 46.</li> <li data-bbox="546 1420 1252 1474">■ The drum unit may be damaged. Put in a new drum unit. See <i>Replacing the drum unit</i> on page 39.</li> </ul>

Examples of poor print quality	Recommendation
 <p data-bbox="134 556 463 614"><b>White lines, bands or ribbing across the page</b></p>	<ul style="list-style-type: none"> <li>■ Check the machine's environment. Conditions such as high humidity and high temperatures may cause this print quality problem.</li> <li>■ If the problem is not solved after printing a few pages, put in a new drum unit. (See <i>Replacing the drum unit</i> on page 39.)</li> </ul>
 <p data-bbox="138 923 458 981">White Spots on black text and graphics at 94 mm intervals</p>  <p data-bbox="138 1277 458 1309">Black Spots at 94 mm intervals</p>	<ul style="list-style-type: none"> <li>■ Make ten copies of a blank, white sheet of paper. See <i>How to copy</i> on page 24. If the problem is not solved, the drum unit may have glue from a label stuck on the OPC drum surface. Clean the drum unit. See <i>Cleaning the drum unit</i> on page 48.</li> <li>■ The drum unit may be damaged. Put in a new drum unit. See <i>Replacing the drum unit</i> on page 39.</li> </ul>
 <p data-bbox="134 1613 463 1671"><b>Black toner marks across the page</b></p>	<ul style="list-style-type: none"> <li>■ Make sure that you use paper that meets our specifications. See <i>Acceptable paper and other print media</i> on page 17.</li> <li>■ If you use label sheets for laser printers, the glue from the sheets may sometimes stick to the OPC drum surface. Clean the drum unit. See <i>Cleaning the drum unit</i> on page 48.</li> <li>■ Do not use paper that has clips or staples because they will scratch the surface of the drum.</li> <li>■ If the unpacked drum unit is in direct sunlight or room light, the unit may be damaged.</li> <li>■ The toner cartridge may be damaged. Put in a new toner cartridge. See <i>Replacing the toner cartridge</i> on page 33.</li> <li>■ The drum unit may be damaged. Put in a new drum unit. See <i>Replacing the drum unit</i> on page 39.</li> </ul>

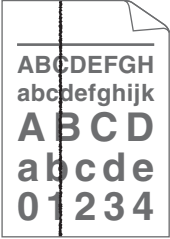

Examples of poor print quality	Recommendation
 <p><b>Black lines down the page</b> Printed pages have toner stains down the page.</p>	<ul style="list-style-type: none"> <li>■ Clean the corona wire inside the drum unit by sliding the green tab. See <i>Cleaning the corona wire</i> on page 46.</li> <li>■ Make sure the green tab of the corona wire is at the home position (▲).</li> <li>■ The drum unit may be damaged. Put in a new drum unit. See <i>Replacing the drum unit</i> on page 39.</li> <li>■ The toner cartridge may be damaged. Put in a new toner cartridge. See <i>Replacing the toner cartridge</i> on page 33.</li> <li>■ The fuser unit may be contaminated. Call your Brother dealer.</li> </ul>
 <p><b>White lines down the page</b></p>	<ul style="list-style-type: none"> <li>■ The toner cartridge may be damaged. Put in a new toner cartridge. See <i>Replacing the toner cartridge</i> on page 33.</li> <li>■ The drum unit may be damaged. Put in a new drum unit. See <i>Replacing the drum unit</i> on page 39.</li> <li>■ Check if the Toner Setting in <i>Replace Toner</i> is set to <i>Continue</i> (Continue mode). See <i>Toner settings</i> in <i>Chapter 1 of the Advanced User's Guide</i>.</li> <li>■ Make sure that a torn piece of paper is not stuck inside the machine blocking the scanner.</li> </ul>
 <p><b>Page skewed</b></p>	<ul style="list-style-type: none"> <li>■ Make sure that the paper or other print media is loaded correctly in the paper tray and that the guides are not too tight or too loose against the paper stack.</li> <li>■ Set the paper guides correctly. See <i>Loading paper</i> on page 9.</li> <li>■ If you are using the manual feed slot, see <i>Loading paper in the manual feed slot</i> on page 11.</li> <li>■ The paper tray may be too full. See <i>Loading paper</i> on page 9.</li> <li>■ Check the paper type and quality. See <i>Acceptable paper and other print media</i> on page 17.</li> <li>■ Check for loose objects such as torn paper inside the machine.</li> <li>■ Verify that the two green envelope levers inside the back cover are set to the same position.</li> <li>■ Verify that the two grey Anti-Curl Levers inside the back cover are set to the same position.</li> <li>■ If the problem only occurs during duplex printing, check for torn paper in the duplex tray, verify that the duplex tray is inserted completely, and verify that the back cover is closed completely.</li> </ul>

B

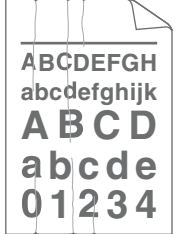
Examples of poor print quality	Recommendation
 <p data-bbox="211 556 385 581"><b>Curled or wavy</b></p>	<ul style="list-style-type: none"> <li data-bbox="513 264 1227 349">■ Check the paper type and quality. High temperatures and high humidity will cause paper to curl. See <i>Acceptable paper and other print media</i> on page 17.</li> <li data-bbox="513 363 1227 484">■ If you do not use the machine often, the paper may have been in the paper tray too long. Turn over the stack of paper in the paper tray. Also, fan the paper stack and then rotate the paper 180° in the paper tray.</li> <li data-bbox="513 498 1227 556">■ Open the back cover (<i>face-up output tray</i>) for the machine to eject printed pages onto the <i>face-up</i> output tray.</li> <li data-bbox="513 569 1227 691">■ Choose <b>Reduce Paper Curl</b> mode in the printer driver when you do not use our recommended paper. See <i>Other Print Options</i> (for Windows®) or <i>Print Settings</i> (For Macintosh) in the <i>Software User's Guide</i>.</li> </ul>
 <p data-bbox="183 994 412 1020"><b>Wrinkles or creases</b></p>	<ul style="list-style-type: none"> <li data-bbox="513 703 1227 761">■ Make sure that the paper is loaded correctly. See <i>Loading paper</i> on page 9.</li> <li data-bbox="513 774 1227 832">■ Check the paper type and quality. See <i>Acceptable paper and other print media</i> on page 17.</li> <li data-bbox="513 846 1227 904">■ Turn over the stack of paper in the tray or try rotating the paper 180° in the input tray.</li> </ul>

Examples of poor print quality	Recommendation
<div data-bbox="255 291 400 542" data-label="Image"> </div> <p data-bbox="226 571 430 602">Envelope creases</p>	<ul data-bbox="543 266 1223 324" style="list-style-type: none"> <li>■ Make sure that the two green envelope levers inside the back cover are pulled down when you print the envelope.</li> </ul> <div data-bbox="646 369 1130 981" data-label="Image"> </div> <p data-bbox="536 1025 654 1070"><b>Note</b></p> <p data-bbox="568 1078 1249 1136">When you have finished printing, open the back cover and reset the two green levers back to their original position.</p>

### Examples of poor print quality

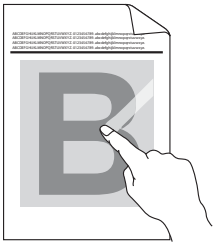

Poor fixing

### Recommendation

- Open the back cover and make sure that the two green envelope levers on the left and right hand sides are in the up position.

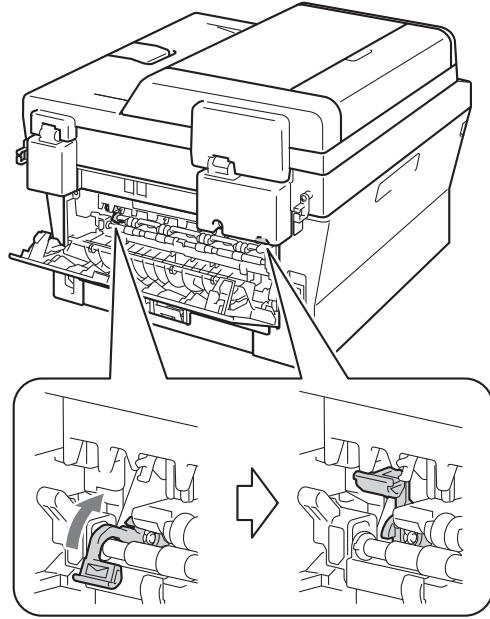

- Choose **Improve Toner Fixing** mode in the printer driver. See *Other Print Options* (for Windows®) or *Print Settings* (For Macintosh) in the *Software User's Guide*. If this selection does not provide enough improvement, select **Thicker Paper** in **Media Type** settings.

Examples of poor print quality	Recommendation
<div data-bbox="253 289 404 531" style="border: 1px solid black; padding: 5px; text-align: center;"> <p>ABCDEF GH                      abcdefghijk  <b>ABCD</b>                      abcde                      01234</p> </div> <p data-bbox="288 569 370 598" style="text-align: center;"><b>Curled</b></p>	<ul style="list-style-type: none"> <li>■ Choose <b>Reduce Paper Curl</b> mode in the printer driver when you do not use our recommended paper. See <i>Other Print Options</i> (for Windows®) or <i>Print Settings</i> (For Macintosh) in the <i>Software User's Guide</i>.</li> <li>■ Turn the paper over in the paper tray, and print again. (Excluding letterhead paper) If the problems remains, switch the Anti-Curl Levers as follows:                     <ol style="list-style-type: none"> <li>1 Open the back cover.</li> <li>2 Lift the lever (1) and slide the two grey levers (2) in the direction of the arrow.</li> </ol> </li> </ul> <div data-bbox="562 666 1227 937" style="border: 1px solid black; padding: 5px;"> </div> <div data-bbox="686 956 1104 1323" style="border: 1px solid black; padding: 5px;"> </div> <div data-bbox="562 1323 1227 1593" style="border: 1px solid black; padding: 5px;"> </div>

**Examples of poor print quality**



**Curled**

**Recommendation**

- Lift up the output tray support flap (1).

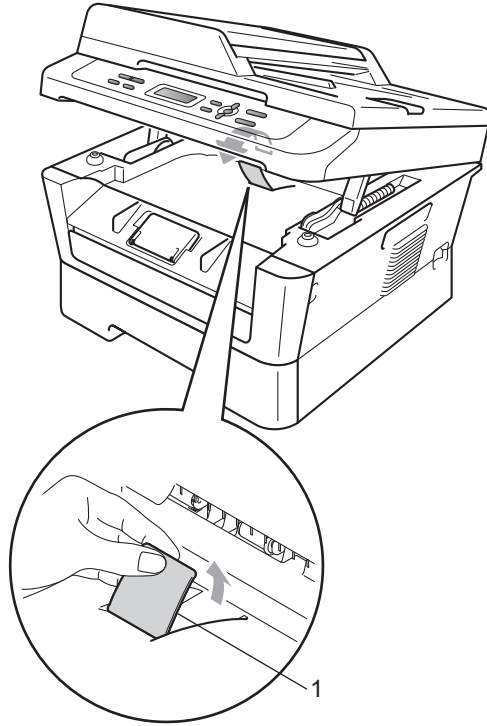

# Machine Information

## Checking the Serial Number

You can see the machine's Serial Number on the LCD.

- 1 Press **Menu**.
- 2 (For DCP-7055 / DCP-7057 / DCP-7060D)  
Press **▲** or **▼** to choose 3.Machine Info..  
Press **OK**.  
  
(For DCP-7055W / DCP-7057W / DCP-7065DN)  
Press **▲** or **▼** to choose 4.Machine Info..  
Press **OK**.  
  
(For DCP-7070DW)  
Press **▲** or **▼** to choose 5.Machine Info..  
Press **OK**.
- 3 Press **▲** or **▼** to choose 1.Serial No..  
Press **OK**.
- 4 Press **Stop/Exit**.

## Reset functions

The following reset functions are available:

- 1 (For DCP-7055W / DCP-7057W / DCP-7065DN / DCP-7070DW)  
Network  
You can reset the internal print server back to its default factory settings such as the password and IP address information.
- 2 All Settings  
You can reset all the machine's settings back to its default factory settings.  
Brother strongly recommends you perform this operation when you dispose of the machine.



### Note

Unplug the interface cable before you choose **Network** or **All Settings**.

## How to reset the machine

- 1 Press **Menu**.
- 2 Press **▲** or **▼** to choose 1.General Setup.  
Press **OK**.
- 3 Press **▲** or **▼** to choose 5.Reset.  
Press **OK**.
- 4 Press **▲** or **▼** to choose the type of reset function you want to use.  
Press **OK**.
- 5 Do one of the following:
  - To reset the settings, press **▲** to choose **Reset**. Then go to step 6.
  - To exit without making changes, press **▼** to choose **Exit**. Then go to step 7.
- 6 You will be asked if you want to reboot the machine. Do one of the following:
  - To reboot the machine, press **▲** to choose **Yes**.  
The machine will begin the reset.
  - To exit without rebooting, press **▼** to choose **No**.  
Then go to step 7.
- 7 Press **Stop/Exit**.

## On-screen programming

Your machine has been designed to be easy to use. The LCD provides on-screen programming using the menu keys.

We have created step by step on-screen instructions to help you program your machine. Simply follow the steps as they guide you through the menu selections and programming options.

### Menu table

---

You can program your machine by using the *Menu table* on page 86. These pages list the menu selections and options. Press **Menu** and then press **▲** or **▼** to access the menus and program your machine. For example, to set Copy Quality to Photo Quality

- 1 Press **Menu**.
- 2 Press **▲** or **▼** to choose *2.Copy*. Press **OK**.
- 3 Press **▲** or **▼** to choose *1.Quality*. Press **OK**.
- 4 Press **▲** or **▼** to choose *Photo*. Press **OK**.
- 5 Press **Stop/Exit**.





## How to access the menu mode

---

- 1 Press **Menu**.
- 2 Choose an option. You can scroll through each menu level by pressing **▲** or **▼** for the direction you want.
- 3 Press **OK** when the option you want appears on the LCD. The LCD will then show the next menu level.
- 4 Press **▲** or **▼** to scroll to your next menu selection.
- 5 Press **OK**. When you have finished setting an option, the LCD will show *Accepted*.
- 6 Press **Stop/Exit** to exit Menu mode.

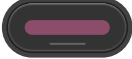

# Menu keys

	
 Menu	Access the menu.
 OK	Go to the next menu level. Accept an option.
 Clear	Exit the menu by pressing repeatedly. Go back to the previous menu level.
	Scroll through the current menu level.
 ⊘ Stop/Exit	Exit the menu.

C

# Menu table

The factory settings are shown in Bold with an asterisk.

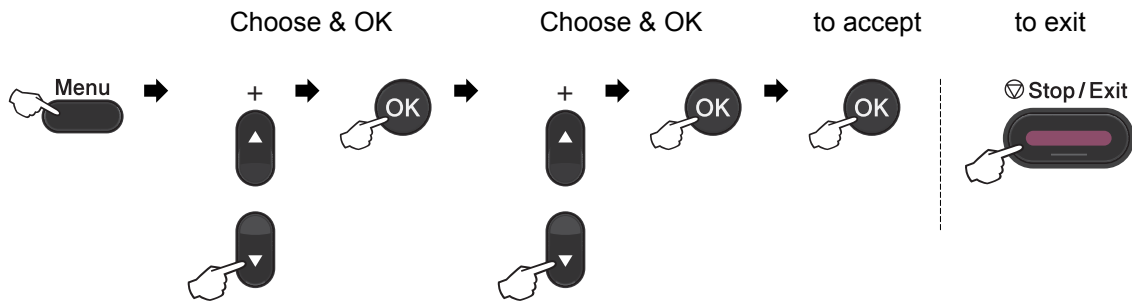

Level 1	Level 2	Level 3	Level 4	Options	Descriptions	Page
1. General Setup	1. Paper	1. Paper Type	—	Thin <b>Plain*</b> Thick Thicker Recycled Paper Label	Sets the type of paper in the paper tray.	16
		2. Paper Size	—	<b>A4*</b> Letter Executive A5 A5 L A6 B5 B6	Sets the size of the paper in the paper tray.	16
	2. Ecology	1. Toner Save	—	On <b>Off*</b>	Increases the page yield of the toner cartridge.	See 1.

<sup>1</sup> See *Advanced User's Guide*.



The factory settings are shown in Bold with an asterisk.

Level 1	Level 2	Level 3	Level 4	Options	Descriptions	Page
1. General Setup (Continued)	2. Ecology (Continued)	2. Sleep Time	—	Range varies depending on models. <b>003Min*</b>	Conserves power.	See <sup>1</sup> .
	3. LCD Contrast	—	—	-□□□■+ -□□□□+ -□□■□+* -□■□□+ -■□□□+	Adjusts the contrast of the LCD.	
	4. Replace Toner	—	—	Continue <b>Stop*</b>	The machine will stop printing until you replace the toner cartridge.	
	5. Reset (For DCP-7055/ DCP-7057/ DCP-7060D)	1. All Settings	—	▲ <b>Reset</b> ▼ <b>Exit</b>	Restores the machine's settings to the original factory default settings.	83
	5. Reset (For DCP-7055W/ DCP-7057W/ DCP-7065DN/ DCP-7070DW)	1. Network	—	▲ <b>Reset</b> ▼ <b>Exit</b>	Restores the machine's network settings to the original factory default settings.	
		2. All Settings	—	▲ <b>Reset</b> ▼ <b>Exit</b>	Restores all the machine's settings to the original factory default settings.	
0. Local Language	—	—	(Choose your language)	—	Allows you to change the LCD language for your country.	8
<sup>1</sup> See <i>Advanced User's Guide</i> .						
 The factory settings are shown in Bold with an asterisk.						

Level 1	Level 2	Level 3	Options	Descriptions	Page
2. Copy	1. <b>Quality</b>	—	<b>Auto*</b> Text Photo Graph	You can choose the Copy resolution for your type of document.	See <sup>1</sup> .
	2. <b>Brightness</b>	—	-□□□■+ -□□□■+ -□□■□+* -■□□□+ -■□□□+	Adjust the brightness for copies.	
	3. <b>Contrast</b>	—	-□□□■+ -□□□■+ -□□■□+* -■□□□+ -■□□□+	Adjusts the contrast for copies.	

<sup>1</sup> See *Advanced User's Guide*.



The factory settings are shown in Bold with an asterisk.

Level 1	Level 2	Level 3	Options	Descriptions	Page
3. Printer (For DCP-7070DW)	1. Print Options	1. <b>Internal Font</b>	—	Prints a list of the machine's internal fonts.	See <sup>2</sup> .
		2. <b>Configuration</b>	—	Prints a list of the machine's printer settings.	
		3. <b>Test Print</b>	—	Prints a test page.	
	2. <b>Duplex</b>	—	<b>Off*</b> On (Long Edge) On (Short Edge)	Enables or disables duplex printing. You can also choose long edge or short edge duplex printing.	
	3. <b>Reset Printer</b>	—	1. <b>Reset</b> 2. <b>Exit</b>	Restores the printer settings to the original factory default settings.	

<sup>1</sup> See *Advanced User's Guide*.

<sup>2</sup> See *Software User's Guide*.



The factory settings are shown in Bold with an asterisk.

Level 1	Level 2	Level 3	Level 4	Options	Descriptions
<b>3 . Network</b> (For DCP-7065DN)	<b>1 . TCP/IP</b>	<b>1 . Boot Method</b>	—	<b>Auto*</b> Static RARP BOOTP DHCP	Chooses the Boot method that best suits your needs.
		<b>2 . IP Address</b>	—	[000-255]. [000-255]. [000-255]. [000-255]	Enter the IP address.
		<b>3 . Subnet Mask</b>	—	[000-255]. [000-255]. [000-255]. [000-255]	Enter the Subnet mask.
		<b>4 . Gateway</b>	—	[000-255]. [000-255]. [000-255]. [000-255]	Enter the Gateway address.
		<b>5 . Node Name</b>	—	BRNXXXXXXXXXXXXXX	Enter the Node name.
		<b>6 . WINS Config</b>	—	<b>Auto*</b> Static	Chooses the WINS configuration mode.
<i>See Network User's Guide.</i>					
 The factory settings are shown in Bold with an asterisk.					

Level 1	Level 2	Level 3	Level 4	Options	Descriptions	
<b>3. Network</b> (For DCP-7065DN) (Continued)	<b>1. TCP/IP</b> (Continued)	<b>7. WINS Server</b>	—	Primary [000-255]. [000-255]. [000-255]. [000-255]  Secondary [000-255]. [000-255]. [000-255]. [000-255]	Specifies the IP address of the primary or secondary WINS server.	
		<b>8. DNS Server</b>	—	Primary [000-255]. [000-255]. [000-255]. [000-255]  Secondary [000-255]. [000-255]. [000-255]. [000-255]	Specifies the IP address of the primary or secondary DNS server.	
		<b>9. APIPA</b>	—	<b>On*</b> Off	Automatically allocates the IP address from the link-local address range.	
		<b>0. IPv6</b>	—	On <b>Off*</b>	Enable or Disable the IPv6 protocol. If you want to use the IPv6 protocol, visit <a href="http://solutions.brother.com/">http://solutions.brother.com/</a> for more information.	
	<b>2. Ethernet</b>	—	—	<b>Auto*</b> 100B-FD 100B-HD 10B-FD 10B-HD	Chooses the Ethernet link mode.	
	<b>3. Status</b>	—	—	Active 100B-FD Active 100B-HD Active 10B-FD Active 10B-HD Inactive Wired OFF	Shows the Ethernet link status.	
	<b>4. MAC Address</b>	—	—	—	Shows the MAC address of the machine.	
	<b>0. Network Reset</b>	—	<b>▲ Reset</b> <b>▼ Exit</b>	Reboot OK? <b>▲ Yes ▼ No</b>	Restore all network settings to factory default.	
	See <i>Network User's Guide</i> .					
	 The factory settings are shown in Bold with an asterisk.					

Level 1	Level 2	Level 3	Level 4	Options	Descriptions
<b>3. Network</b> (For DCP-7055W/ DCP-7057W)	<b>1. TCP/IP</b>	<b>1. Boot Method</b>	—	<b>Auto*</b> Static RARP BOOTP DHCP	Chooses the Boot method that best suits your needs.
		<b>2. IP Address</b>	—	[000-255]. [000-255]. [000-255]. [000-255]	Enter the IP address.
		<b>3. Subnet Mask</b>	—	[000-255]. [000-255]. [000-255]. [000-255]	Enter the Subnet mask.
		<b>4. Gateway</b>	—	[000-255]. [000-255]. [000-255]. [000-255]	Enter the Gateway address.
		<b>5. Node Name</b>	—	BRWXXXXXXXXXXXX	Enter the Node name.
		<b>6. WINS Config</b>	—	<b>Auto*</b> Static	Chooses the WINS configuration mode.
		<b>7. WINS Server</b>	—	Primary [000-255]. [000-255]. [000-255]. [000-255] Secondary [000-255]. [000-255]. [000-255]. [000-255]	Specifies the IP address of the primary or secondary WINS server.
		<b>8. DNS Server</b>	—	Primary [000-255]. [000-255]. [000-255]. [000-255] Secondary [000-255]. [000-255]. [000-255]. [000-255]	Specifies the IP address of the primary or secondary DNS server.
		<b>9. APIPA</b>	—	<b>On*</b> Off	Automatically allocates the IP address from the link-local address range.
	<b>0. IPv6</b>	—	On <b>Off*</b>	Enable or Disable the IPv6 protocol. If you want to use the IPv6 protocol, visit <a href="http://solutions.brother.com/">http://solutions.brother.com/</a> for more information.	
	<b>2. Setup Wizard</b>	—	—	—	You can configure your print server.
	<b>3. WPS/AOSS</b>	—	—	—	You can easily configure your wireless network settings using the one-button push method.
	<b>4. WPS w/PIN Code</b>	—	—	—	You can easily configure your wireless network settings using WPS with a PIN code.

See *Network User's Guide*.





The factory settings are shown in Bold with an asterisk.

Level 1	Level 2	Level 3	Level 4	Options	Descriptions
<b>3. Network</b> (For DCP-7055W / DCP-7057W) (Continued)	<b>5. WLAN Status</b>	<b>1. Status</b>	—	Active (11b) Active (11g) WLAN OFF AOSS Active Connection Fail	You can see the current wireless network status.
		<b>2. Signal</b>	—	Strong Medium Weak None	You can see the current wireless network signal strength.
		<b>3. SSID</b>	—	—	You can see the current SSID.
		<b>4. Comm. Mode</b>	—	Ad-hoc Infrastructure	You can see the current Communication Mode.
	<b>6. MAC Address</b>	—	—	—	Shows the MAC address of the machine.
	<b>7. WLAN Enable</b>	—	—	On <b>Off*</b>	Enable or disable the wireless LAN manually.
	<b>0. Network Reset</b>	—	—	▲ <b>Reset</b> ▼ <b>Exit</b>	Restores all network settings to factory default.
	See <i>Network User's Guide</i> .				
 The factory settings are shown in Bold with an asterisk.					



Level 1	Level 2	Level 3	Level 4	Options	Descriptions
4. Network (For DCP-7070DW)	1. Wired LAN	1. TCP/IP	1. Boot Method	<b>Auto*</b> Static RARP BOOTP DHCP	Chooses the Boot method that best suits your needs.
			2. IP Address	[000-255]. [000-255]. [000-255]. [000-255]	Enter the IP address.
			3. Subnet Mask	[000-255]. [000-255]. [000-255]. [000-255]	Enter the Subnet mask.
			4. Gateway	[000-255]. [000-255]. [000-255]. [000-255]	Enter the Gateway address.
			5. Node Name	BRNXXXXXXXXXXXXXX	Enter the Node name.
			6. WINS Config	<b>Auto*</b> Static	Chooses the WINS configuration mode.
			7. WINS Server	Primary [000-255]. [000-255]. [000-255]. [000-255] Secondary [000-255]. [000-255]. [000-255]. [000-255]	Specifies the IP address of the primary or secondary WINS server.
			8. DNS Server	Primary [000-255]. [000-255]. [000-255]. [000-255] Secondary [000-255]. [000-255]. [000-255]. [000-255]	Specifies the IP address of the primary or secondary DNS server.
			9. APIPA	<b>On*</b> Off	Automatically allocates the IP address from the link-local address range.
			0. IPv6	On <b>Off*</b>	Enable or Disable the IPv6 protocol. If you want to use the IPv6 protocol, visit <a href="http://solutions.brother.com/">http://solutions.brother.com/</a> for more information.
See <i>Network User's Guide</i> .					
 The factory settings are shown in Bold with an asterisk.					

Level 1	Level 2	Level 3	Level 4	Options	Descriptions	
<b>4. Network</b> (For DCP-7070DW) (Continued)	<b>1. Wired LAN</b> (Continued)	<b>2. Ethernet</b>	—	<b>Auto*</b> 100B-FD 100B-HD 10B-FD 10B-HD	Chooses the Ethernet link mode.	
		<b>3. Wired Status</b>	—	Active 100B-FD Active 100B-HD Active 10B-FD Active 10B-HD Inactive Wired OFF	You can see the current wired status.	
		<b>4. MAC Address</b>	—	—	Shows the MAC address of the machine.	
		<b>5. Set to Default</b>	—	1. Reset 2. Exit	Restore the wired network setting to factory default.	
		<b>6. Wired Enable</b>	—	<b>On*</b> Off	Enable or Disable the Wired LAN manually.	
	<b>2. WLAN</b>	<b>1. TCP/IP</b>	<b>1. Boot Method</b>	<b>Auto*</b> Static RARP BOOTP DHCP	Chooses the Boot method that best suits your needs.	
			<b>2. IP Address</b>	[000-255]. [000-255]. [000-255]. [000-255]	Enter the IP address.	
			<b>3. Subnet Mask</b>	[000-255]. [000-255]. [000-255]. [000-255]	Enter the Subnet mask.	
			<b>4. Gateway</b>	[000-255]. [000-255]. [000-255]. [000-255]	Enter the Gateway address.	
			<b>5. Node Name</b>	BRWXXXXXXXXXXXXX	Enter the Node name.	
			<b>6. WINS Config</b>	<b>Auto*</b> Static	Chooses the WINS configuration mode.	
	See <i>Network User's Guide</i> .					
	 The factory settings are shown in Bold with an asterisk.					

Level 1	Level 2	Level 3	Level 4	Options	Descriptions
4. Network (For DCP-7070DW) (Continued)	2. WLAN (Continued)	1. TCP/IP (Continued)	7. WINS Server	Primary [000-255]. [000-255]. [000-255]. [000-255]  Secondary [000-255]. [000-255]. [000-255]. [000-255]	Specifies the IP address of the primary or secondary WINS server.
			8. DNS Server	Primary [000-255]. [000-255]. [000-255]. [000-255]  Secondary [000-255]. [000-255]. [000-255]. [000-255]	Specifies the IP address of the primary or secondary DNS server.
			9. APIPA	On*  Off	Automatically allocates the IP address from the link-local address range.
			0. IPv6	On  Off*	Enable or Disable the IPv6 protocol. If you want to use the IPv6 protocol, visit <a href="http://solutions.brother.com/">http://solutions.brother.com/</a> for more information.
		2. Setup Wizard	—	—	You can configure your print server.
		3. WPS/AOSS	—	—	You can easily configure your wireless network settings using the one-button push method.
		4. WPS w/PIN Code	—	—	You can easily configure your wireless network settings using WPS with a PIN code.
See <i>Network User's Guide</i> .					
 The factory settings are shown in Bold with an asterisk.					

Level 1	Level 2	Level 3	Level 4	Options	Descriptions
<b>4. Network</b> (For DCP-7070DW) (Continued)	<b>2. WLAN</b> (Continued)	<b>5. WLAN Status</b>	<b>1. Status</b>	Active (11b) Active (11g) Wired LAN Active WLAN OFF AOSS Active Connection Fail	You can see the current wireless network status.
			<b>2. Signal</b>	Strong Medium Weak None	You can see the current wireless network signal strength.
			<b>3. SSID</b>	—	You can see the current SSID.
			<b>4. Comm. Mode</b>	Ad-hoc Infrastructure	You can see the current Communication Mode.
		<b>6. MAC Address</b>	—	—	Shows the MAC address of the machine.
		<b>7. Set to Default</b>	—	1. Reset 2. Exit	Restore the wireless network settings to factory default.
	<b>8. WLAN Enable</b>	—	On <b>Off*</b>	Enable or disable the wireless LAN manually.	
<b>0. Network Reset</b>	—	<b>▲ Reset</b> <b>▼ Exit</b>	Reboot OK? <b>▲ Yes ▼ No</b>	Restores all network settings to factory default.	
See <i>Network User's Guide</i> .					
 The factory settings are shown in Bold with an asterisk.					

Level 1	Level 2	Level 3	Options	Descriptions	Page
<b>3.Machine Info.</b> (For DCP-7055, DCP-7057 and DCP-7060D)  <b>4.Machine Info.</b> (For DCP-7055W / DCP-7057W / DCP-7065DN)  <b>5.Machine Info.</b> (For DCP-7070DW)	<b>1.Serial No.</b>	—	—	You can check the serial number of your machine.	83
	<b>2.Page Counter</b>	—	Total List Copy Print	You can check the number of total pages the machine has printed during its life.	See <sup>1</sup> .
	<b>3.User Settings</b>	—	—		
	<b>4.Network Config</b> (For DCP-7055W / DCP-7057W / DCP-7065DN / DCP-7070DW)	—	—		
	<b>5.WLAN Report</b> (For DCP-7055W / DCP-7057W / DCP-7070DW)	—	—		
	<b>4.Drum Life</b> (For DCP-7055 / DCP-7057 / DCP-7060D)  <b>5.Drum Life</b> (For DCP-7065DN)  <b>6.Drum Life</b> (For DCP-7055W / DCP-7057W / DCP-7070DW)	—	—	—	You can check the percentage of a Drum life that remains available.
<sup>1</sup> See <i>Advanced User's Guide</i> .					
 The factory settings are shown in Bold with an asterisk.					

## General



### Note

This chapter provides a summary of the machines' specifications. For additional specifications visit <http://www.brother.com/> for details.

<b>Printer Type</b>	Laser	
<b>Print Method</b>	Electrophotography by semiconductor laser beam scanning	
<b>Memory Capacity</b>	(For DCP-7055 / DCP-7057) 16 MB (For DCP-7055W / DCP-7057W / DCP-7060D / DCP-7065DN / DCP-7070DW) 32 MB	
<b>LCD (liquid crystal display)</b>	16 characters × 2 lines	
<b>Power Source</b>	220 - 240 V AC 50/60Hz	
<b>Power Consumption</b> <sup>1</sup>	Peak:	1080 W
	Copying: <sup>2</sup>	Approx. 445 W at 25 °C
	Ready:	Approx. 55 W at 25 °C
	<b>For Wireless models</b>	
	(WLAN: On) Sleep:	Approx. 2.8 W
	(WLAN: Off) Deep Sleep:	(For DCP-7055W / DCP-7057W / DCP-7070DW) Approx. 1.0 W
	<b>For non-Wireless models</b>	
	Deep Sleep:	Approx. 0.9 W



### Note

All figures stated above (except Peak) are average figures.

<sup>1</sup> USB connection to PC

<sup>2</sup> When making a copy from one sheet

## Dimensions

## DCP-7065DN

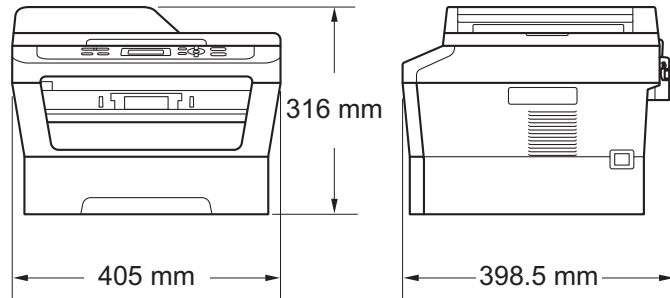

## DCP-7055 / DCP-7055W / DCP-7057 / DCP-7057W / DCP-7060D / DCP-7070DW

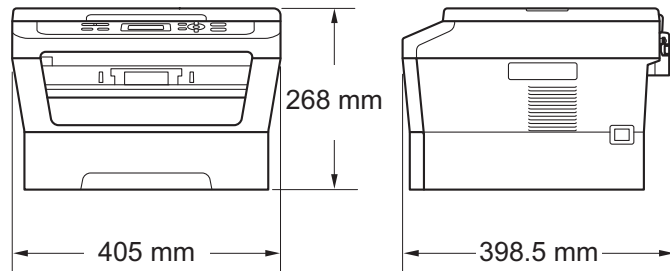

## Weight

With Consumables:

(For DCP-7055 / DCP-7055W /  
DCP-7057 / DCP-7057W) 9.8 kg  
(For DCP-7060D) 10.1 kg  
(For DCP-7065DN) 11.4 kg  
(For DCP-7070DW) 10.3 kg

**Noise level****Sound power**<sup>1</sup>

Operating:	(For DCP-7055 / DCP-7055W / DCP-7057 / DCP-7057W) LWAd = 6.60 B (A)
	(For DCP-7060D / DCP-7065DN / DCP-7070DW) LWAd = 6.40 B (A) <sup>2</sup>
Standby:	(For DCP-7055 / DCP-7055W / DCP-7057 / DCP-7057W) LWAd = 4.30 B (A)
	(For DCP-7060D) LWAd = 4.27 B (A)
	(For DCP-7065DN / DCP-7070DW) LWAd = 4.22 B (A)

**Sound pressure**

Operating (Printing):	LPAm = 53 dB (A)
Standby:	LPAm = 30 dB (A)

<sup>1</sup> Measured in accordance with ISO 9296.

<sup>2</sup> Office equipment with LWAd > 6.30 B (A) is not suitable for use in room where people do primarily intellectual work. Such equipment should be placed in separate rooms because of the noise emission.

**Temperature**

Operating:	10 to 32.5°C
Storage:	0 to 40°C

**Humidity**

Operating:	20 to 80% (without condensation)
Storage:	10 to 90% (without condensation)

**ADF (automatic document feeder)**

Up to 35 pages (Staggered) [80 g/m<sup>2</sup>]

(For DCP-7065DN)



## Document Size

### Document Size (Single-sided)

ADF Width: (For DCP-7065DN)	147.3 to 215.9 mm
ADF Length: (For DCP-7065DN)	147.3 to 355.6 mm
Scanner Glass Width:	Max. 215.9 mm
Scanner Glass Length:	Max. 297 mm

# Print media

<b>Paper Input</b>	<b>Paper Tray</b>	
	■ Paper Type:	Plain paper, Thin paper or Recycled paper
	■ Paper Size:	Letter, A4, B5 (ISO/JIS), A5, A5 (Long Edge), B6 (ISO), A6, Executive
	■ Paper Weight:	60 to 105 g/m <sup>2</sup>
	■ Maximum Paper Tray Capacity:	Up to 250 sheets of 80 g/m <sup>2</sup> Plain paper
	<b>Manual Feed Slot (Manual)</b>	
	■ Paper Type:	Envelopes, Labels <sup>1</sup> , Thin paper, Thick paper, Thicker paper, Recycled paper, Bond paper or Plain paper
	■ Paper Size:	Width: 76.2 to 216 mm Length: 116 to 406.4 mm
	■ Paper Weight:	60 to 163 g/m <sup>2</sup> <sup>2</sup>
	■ Maximum Paper Tray Capacity:	One sheet at a time 80 g/m <sup>2</sup> Plain paper
<b>Paper Output</b>	<b>Face-Down Output Tray</b>	Up to 100 sheets ( <i>face down</i> print delivery to the <i>Face down</i> output paper tray)
	<b>Face-Up Output Tray</b>	One sheet ( <i>face up</i> print delivery to the <i>Face up</i> output paper tray)
<b>Duplex Printing</b>  (For DCP-7060D / DCP-7065DN / DCP-7070DW)	■ Paper Size (Automatic Duplex):	A4
	■ Paper Weight (Automatic Duplex):	60 to 105 g/m <sup>2</sup>
	■ Paper Type (Automatic Duplex):	Plain paper or Recycled paper

<sup>1</sup> For labels, we recommend removing printed pages from the output paper tray immediately after they exit the machine to avoid the possibility of smudging.

<sup>2</sup> 60 to 105 g/m<sup>2</sup> for duplex print.

# Copy

<b>Color/Monochrome</b>	Monochrome
<b>Copy Width</b>	Max. 204 mm
<b>Multiple Copies</b>	Stacks or Sorts up to 99 pages
<b>Reduce/Enlarge</b>	25% to 400% (in increments of 1%)
<b>Resolution</b>	Up to 600 × 600 dpi
<b>First Copy Out Time</b>	(For DCP-7055 / DCP-7055W / DCP-7057 / DCP-7057W) Less than 12 seconds (from the READY mode and standard tray) (For DCP-7060D / DCP-7065DN / DCP-7070DW) Less than 11 seconds (from the READY mode and standard tray)
<b>Ready</b>	At 25°C

# Scanner

<b>Colour/Black</b>	Yes/Yes
<b>TWAIN Compliant</b>	Yes (Windows® 2000 Professional/Windows® XP/ Windows® XP Professional x64 Edition/Windows Vista®/ Windows® 7)  Mac OS X 10.4.11, 10.5.x, 10.6.x <sup>1</sup>
<b>WIA Compliant</b>	Yes (Windows® XP/Windows Vista®/Windows® 7)
<b>Colour Depth</b>	48 bit internal / 24 bit external colour
<b>Resolution</b>	Up to 19200 × 19200 dpi (interpolated) <sup>2</sup> Up to 600 × 2400 dpi (optical) <sup>2</sup> (from Scanner Glass) Up to 600 × 600 dpi (optical) <sup>2</sup> (from ADF (For DCP-7065DN))
<b>Scanning Width</b>	Max. 204 mm
<b>Greyscale</b>	256 levels

<sup>1</sup> For the latest driver updates for the Mac OS X you are using, visit us at <http://solutions.brother.com/>.

<sup>2</sup> Maximum 1200 × 1200 dpi scanning with the WIA driver in Windows® XP, Windows Vista® and Windows® 7 (resolution up to 19200 × 19200 dpi can be chosen by using the scanner utility)

# Printer

<b>Automatic 2-sided (Duplex) Print</b>	Yes
(For DCP-7060D / DCP-7065DN / DCP-7070DW)	
<b>Emulations</b>	PCL6
(For DCP-7070DW)	
<b>Resolution</b>	600 dpi × 600 dpi, HQ1200 (2400 × 600 dpi) quality
<b>Print Speed (Duplex)</b>	Up to 5 pages/minute (A4 size) <sup>1</sup>
<b>Print Speed</b>	(For DCP-7055 / DCP-7055W / DCP-7057 / DCP-7057W) Up to 20 pages/minute (A4 size) <sup>1</sup>
	(For DCP-7060D) Up to 24 pages/minute (A4 size) <sup>1</sup>
	(For DCP-7065DN / DCP-7070DW) Up to 26 pages/minute (A4 size) <sup>1</sup>
<b>First Print Out Time</b>	(For DCP-7055 / DCP-7055W / DCP-7057 / DCP-7057W) Less than 10.0 seconds (from the READY mode and standard tray)
	(For DCP-7060D / DCP-7065DN / DCP-7070DW) Less than 8.5 seconds (from the READY mode and standard tray)

<sup>1</sup> The print speed may vary depending on the type of document you print.

# Interfaces

## USB

We recommend to use a USB cable (Type A/B) that is no more than 2 metres long.<sup>1 2</sup>

## Ethernet<sup>3</sup>

(DCP-7065DN /  
DCP-7070DW)

Use an Ethernet UTP cable category 5 or greater.

## Wireless LAN

(DCP-7055W /  
DCP-7057W /  
DCP-7070DW)

IEEE 802.11 b/g (Infrastructure / Ad-hoc Mode)

<sup>1</sup> Your machine has a Hi-Speed USB 2.0 interface. The machine can also be connected to a computer that has a USB 1.1 interface.

<sup>2</sup> Third-party USB ports are not supported.

<sup>3</sup> See *Network (DCP-7055W / DCP-7057W / DCP-7065DN / DCP-7070DW)* on page 110 and the Network User's Guide for detailed network specifications.

# Computer requirements

Minimum System Requirements and Supported PC Software Functions								
Computer Platform & Operating System Version		Processor Minimum Speed	Minimum RAM	Recommended RAM	Hard Disk Space to install		Supported PC Software Functions	Supported PC Interface <sup>3</sup>
					For Drivers	For Applications		
Windows® Operating System <sup>1</sup>	Windows® 2000 Professional <sup>4</sup>	Intel® Pentium® II or equivalent	64 MB	256 MB	150 MB	500 MB	Printing, Scanning	USB, 10/100 Base Tx (Ethernet), Wireless 802.11 b/g
	Windows® XP Home <sup>2 5</sup> Windows® XP Professional <sup>2 5</sup>		128 MB					
	Windows® XP Professional x64 Edition <sup>2 5</sup>	64-bit (Intel®64 or AMD64) supported CPU	256 MB	512 MB				
	Windows Vista® <sup>2 5</sup>	Intel® Pentium® 4 or equivalent 64-bit (Intel®64 or AMD64) supported CPU	512 MB	1 GB	500 MB	1.2 GB		
	Windows® 7 <sup>2 5</sup>	Intel® Pentium® 4 or equivalent 64-bit (Intel®64 or AMD64) supported CPU	1 GB (32-bit) 2 GB (64-bit)	1 GB (32-bit) 2 GB (64-bit)	650 MB			

Minimum System Requirements and Supported PC Software Functions								
Computer Platform & Operating System Version		Processor Minimum Speed	Minimum RAM	Recommended RAM	Hard Disk Space to install		Supported PC Software Functions	Supported PC Interface <sup>3</sup>
					For Drivers	For Applications		
Windows® Operating System <sup>1</sup>	Windows Server® 2003 (print only via network)	Intel® Pentium® III or equivalent	256 MB	512 MB	50 MB	N/A	Printing	10/100 Base Tx (Ethernet), Wireless 802.11 b/g
	Windows Server® 2003 x64 Edition (print only via network)	64-bit (Intel®64 or AMD64) supported CPU						
	Windows Server® 2008 (print only via network)	Intel® Pentium® 4 or equivalent 64-bit (Intel®64 or AMD64) supported CPU	512 MB	2 GB				
	Windows Server® 2008 R2 (print only via network)	64-bit (Intel®64 or AMD64) supported CPU						
Macintosh Operating System	Mac OS X 10.4.11 10.5.x	PowerPC G4/G5 Intel® Core™ Processor	512 MB	1 GB	80 MB	400 MB	Printing, Scanning	USB, 10/100 Base Tx (Ethernet), Wireless 802.11 b/g
	Mac OS X 10.6.x	Intel® Core™ Processor	1 GB	2 GB				

<sup>1</sup> Internet Explorer® 6.0 or greater.

<sup>2</sup> For WIA, 1200 x 1200 resolution. Brother Scanner Utility enables to enhance up to 19200 x 19200 dpi.

<sup>3</sup> Third-party USB ports are not supported.

<sup>4</sup> PaperPort™ 11SE supports Microsoft® SP4 or higher for Windows® 2000.

<sup>5</sup> PaperPort™ 12SE supports Microsoft® SP3 or higher for Windows® XP and SP2 or higher for Windows Vista® and Windows® 7.

For the latest driver updates, visit <http://solutions.brother.com/>.

All trademarks, brand and product names are property of their respective companies.



## Consumable items

Russian customers: Please refer to the Russian guide for information on your consumable items.

<b>Toner Cartridge</b>	Starter Toner Cartridge: (Except DCP-7065DN / DCP-7070DW)	Approx. 700 pages (A4) <sup>1</sup>
	Standard Toner Cartridge: TN-2010 (For DCP-7055 / DCP-7055W / DCP-7057)	Approx. 1,000 pages (A4) <sup>1</sup>
	TN-2210 (For DCP-7060D / DCP-7065DN / DCP-7070DW)	Approx. 1,200 pages (A4) <sup>1</sup>
	High-Yield Toner Cartridge: TN-2220 (For DCP-7060D / DCP-7065DN / DCP-7070DW)	Approx. 2,600 pages (A4) <sup>1</sup>
<b>Drum Unit</b>	DR-2200	Approx. 12,000 pages (A4) <sup>2</sup>

<sup>1</sup> Approx. cartridge yield is declared in accordance with ISO/IEC 19752.

<sup>2</sup> Drum yield is approximate, and may vary by type of use.

# Network (DCP-7055W / DCP-7057W / DCP-7065DN / DCP-7070DW)



## Note

For details about the full Network specifications, see the *Network User's Guide*.

### LAN

You can connect your machine to a network for Network Printing and Network Scanning. Also included is Brother BRAdmin Light <sup>1</sup> Network Management software.

### Security Protocols

#### Wired

(DCP-7065DN / DCP-7070DW)

APOP, POP before SMTP, SMTP-AUTH

#### Wireless

(DCP-7055W / DCP-7057W / DCP-7070DW)

APOP, POP before SMTP, SMTP-AUTH

**Wireless Network Security**  
(DCP-7055W / DCP-7057W / DCP-7070DW)

WEP 64/128 bit, WPA-PSK (TKIP/AES), WPA2-PSK (AES)

**Wireless Network Setup Support Utility**  
(DCP-7055W / DCP-7057W / DCP-7070DW)

**AOSS™** Yes

**WPS** Yes

<sup>1</sup> BRAdmin Professional and Web BRAdmin (not available for DCP-7055W / DCP-7057W) are available as a download from <http://solutions.brother.com/>.

# E

## Index

### A

---

ADF (automatic document feeder)  
using .....21

### C

---

Cleaning  
  Cleaning:paper pick-up rollers .....52  
  corona wire .....46  
  drum unit .....48  
  scanner .....45  
Consumable items .....32  
  disposal .....37  
  replacing .....54  
Control panel overview .....6  
Copy .....24  
  keys .....6

### D

---

Document  
  how to load ..... 21, 22  
  jams .....57  
Drum unit  
  cleaning ..... 46, 48  
  replacing .....39  
Duplex  
  key .....6  
  paper jam .....66  
  printing .....102  
  troubleshooting ..... 55, 69

### E

---

Envelopes .....12, 17, 19  
Error messages on LCD ..... 54  
  Drum Error ..... 39  
  Drum Stop ..... 39  
  Duplex Disabled ..... 55  
  Init Unable XX ..... 55  
  Jam Duplex ..... 55  
  No Paper ..... 55  
  Out of Memory ..... 56  
  Print Unable XX ..... 56  
  Replace Drum ..... 39  
  Replace Toner ..... 34  
  Toner Ended ..... 34  
  Toner Low ..... 34

### F

---

Folio ..... 16, 17

### G

---

Greyscale ..... 104

### H

---

HELP  
  LCD messages ..... 84  
  Menu Table ..... 86

### J

---

Jams  
  document ..... 57  
  paper ..... 59

### L

---

Labels ..... 11, 12, 17, 20  
LCD (liquid crystal display) ..... 7, 84

## M

---

Machine information	
how to reset the machine .....	83
reset functions .....	83
serial number .....	83
Maintenance, routine .....	44
replacing	
drum unit .....	39
toner cartridge .....	33
Menu Table .....	86
Mode, entering	
copy .....	24

## O

---

OPC drum .....	76
Out of Memory message .....	56

## P

---

Paper .....	17, 102
how to load .....	9
in manual feed slot .....	11
in paper tray .....	9
jams .....	55, 59
recommended .....	17, 18
size .....	16, 17
tray capacity .....	17
type .....	16, 17
Print	
difficulties .....	68
emulation .....	105
quality .....	70
resolution .....	105
specifications .....	105
Print quality .....	73
Programming your machine .....	84

## Q

---

Quality	
printing .....	70

## R

---

Replacing	
drum unit .....	39
toner cartridge .....	33
Resolution	
copy .....	103
print .....	105
scan .....	104

## S

---

Safety Instructions .....	i
Scan .....	6, 26
Scanner glass	
using .....	22
Serial number	
how to find .....	See inside front cover

## T

---

Toner cartridge	
replacing .....	33
Troubleshooting .....	54
document jam .....	57, 58
error messages on LCD .....	54
if you are having difficulty	
copy quality .....	68
network .....	71
paper handling .....	70
print quality .....	70
printing .....	68
scanning .....	69
software .....	69
maintenance messages on LCD .....	54
paper jam .....	59, 60, 62, 66



**brother**<sup>®</sup>

These machines are approved for use in the country of purchase only. Local Brother companies or their dealers will only support machines purchased in their own countries.