

brother®

TZ  
TAPE

HG  
TAPE

*P-touch*

9700PC / 9800PCN

---

*User's Guide*

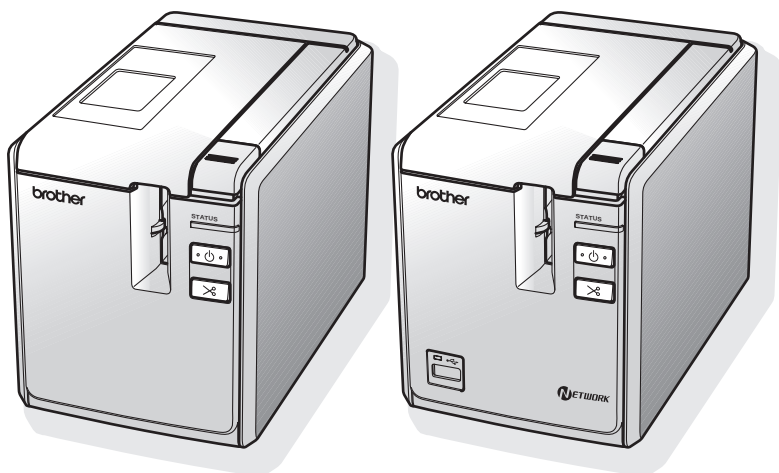

If you encounter any problems with your product, visit our Web site:  
<http://solutions.brother.com/>

## Introduction

Thank you for purchasing the PT-9700PC/PT-9800PCN.

The PT-9700PC/PT-9800PCN (hereafter, referred to as “printer”) is a label printer that enables you to easily print custom labels after it is connected to a computer. Also, with a bar code reader connected to the printer, labels and bar codes can easily be printed by scanning bar codes.

This manual contains various precautions and basic procedures for using this printer. Read this manual carefully before starting and keep the manual in a handy place for future reference.



### **International ENERGY STAR® Compliance Statement**

The purpose of the International ENERGY STAR® Program is to promote the development and popularization of energy-efficient office equipment.

As an ENERGY STAR® Partner, Brother Industries, Ltd. has determined that this product meets the ENERGY STAR® guidelines for energy efficiency.

## Compilation and Publication Notice

Under the supervision of Brother Industries Ltd., this manual has been compiled and published, covering the latest product's descriptions and specifications.

The contents of this manual and the specifications of this product are subject to change without notice.

If new versions of the PT-9700PC/9800PCN software become available, this manual may not reflect the updated features. Therefore, you may find that the software and the contents in this manual are different.

Brother reserves the right to make changes without notice in the specifications and materials contained herein and shall not be responsible for any damages (including consequential) caused by reliance on the materials presented, including but not limited to typographical and other errors relating to the publication. The screen images in this manual may differ depending on your OS or printer.

© 2010 Brother Industries, Ltd.

## Trademarks and Copyrights

The Brother logo is a registered trademark of Brother Industries, Ltd.

Brother is a registered trademark of Brother Industries, Ltd.

© 2010 Brother Industries, Ltd. All rights reserved.

Microsoft, Windows Vista, Windows Server and Windows are registered trademarks of Microsoft Corporation in the United States and other countries.

Apple, Macintosh and Mac OS are trademarks of Apple Inc., registered in the United States and other countries.

QR Code is a registered trademark of DENSO WAVE INCORPORATED in JAPAN and other countries. QR Code Generating Program Copyright © 2008 DENSO WAVE INCORPORATED.

BarStar Pro Encode Library (DataMatrix, MaxiCode, PDF417, RSS) Copyright © 2007 AINIX Corporation. All rights reserved.

The names of other software or products used in this document are trademarks or registered trademarks of the respective companies that developed them.

Each company whose software title is mentioned in this manual has a Software Licence Agreement specific to its proprietary programs.

Any trade names and product names of companies appearing on Brother products, related documents and any other materials are all trademarks or registered trademarks of those respective companies.

## For Australia Only:

**Support** - For technical support of your Brother Product other than what you can resolve through the User's Guide, please visit our Web Site or Solutions Web Site (see below) to find an answer to FAQs/Troubleshooting, locating Drivers & Software.

Alternatively, please contact the Product Support Centre for any customer care/technical support enquiry.

**To contact Brother International (Aust) Pty Ltd for support on a Brother product please see the details listed below:**

Product Support Centre: **Australia**

Brother International (Aust) Pty Ltd

Phone: 02 8875 6000

Fax: 02 9870 7223

Solutions Site: <http://solutions.brother.com>



Web Site: [www.brother.com.au](http://www.brother.com.au)

Email: To submit an e-mail enquiry, visit [www.brother.com.au](http://www.brother.com.au) go to **Service and Support** area and follow the prompts.









Our Technical Support Consultants are available 5 days a week by phone during the hours of 8.30am to 5.00pm (EST/EDST) Monday to Friday.

## Safety precautions

To prevent injury and damage, important notes are explained using various symbols. The symbols and their meanings are as follows:

 <b>WARNING</b>	Tells you what to do to avoid accidents and the risk of injury.
 <b>CAUTION</b>	Tells you about procedures you must follow to avoid minor personal injury or damage to the printer.











The symbols used in this manual are as follows:

	Action NOT allowed.		DO NOT disassemble the product.
	DO NOT splash the product with or immerse the product in water.		DO NOT touch a given portion of the product.
	Mandatory action		Unplugging
	Safety alert		Alerts to the possibility of electrical shock

### WARNING

#### AC adapter



Follow these guidelines to avoid fire, damage, electric shock, failure or the risk of injury.

-  Use only the AC adapter (AD9100ES), adapter cord, power supply cord and USB cable designed exclusively for your printer. Failure to observe this may result in an accident or damage. Brother shall not assume any responsibility for any accident or damage resulting from not using the specified AC adapter (AD9100ES), adapter cord, power supply cord and USB cable.
-  Don't connect the enclosed AC adapter (AD9100ES), adapter cord, power supply cord and USB cable to other products.
-  Unplug the power supply cord immediately and stop using the printer during an electrical storm. There may be a remote risk of electric shock from lightning.
-  Do not touch the AC adapter or power plug with wet hands.
-  Do not use the AC adapter in places of high humidity such as bathrooms.
-  Do not use a damaged adapter cord or power supply cord.
-  Do not overload the power outlet.
-  Do not place heavy objects on, damage or modify adapter/power supply cord or plug. Do not forcibly bend or pull these cord.
-  Do not drop, hit or otherwise damage the AC adapter.
-  Make sure that the plug is fully inserted in the power outlet. Do not use an outlet that is loose.

## WARNING





### Printer

Follow these guidelines to avoid fire, damage, electric shock, and/or the risk of injury.

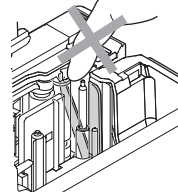
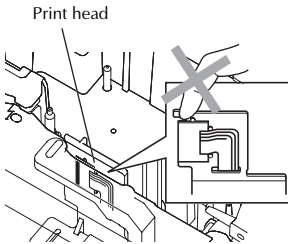
-  Do not allow the printer to get wet in any way.
-  Do not touch the blade of the cutter unit.

-  Do not touch any metal parts near the print head. The print head becomes very hot during use and remains very hot immediately after use. Do not touch it directly with your hands.



-  Do not use the printer with a foreign object in it. If water, metallic substance or any foreign object enters the printer, disconnect the AC adapter and contact the retail outlet where the printer was purchased or your local authorised service center.
-  Do not disassemble the printer. For inspection, adjustment, and repair of the printer, contact the retail outlet where the printer was purchased or your local authorised service center.
-  Plastic bags are used in the packaging of your printer. To avoid danger of suffocation, keep these bags away from babies and children.
-  Disconnect the AC adapter immediately and stop using when you notice abnormal odour, heat, discolouration, deformation or anything unusual while using or storing it.
-  To prevent damage, do not drop or hit the printer.

## CAUTION

Follow these guidelines to avoid minor personal injury and damage to the printer.



### Tape cutter

-  Do not open the tape compartment cover when operating the cutter unit.
-  Do not apply excessive pressure to the cutter unit.

### AC adapter

-  If you do not intend using the printer for an extended period of time, please disconnect the AC adapter from the power outlet.
-  Always hold the plug when disconnecting the power supply cord from the power outlet.



### Printer

-  Place the printer on a flat, stable surface such as a desk.
-  Do not place any heavy objects on top of the printer.
-  Do not leave the printer within reach of children with the tape compartment cover open.

---

## General Precautions

---

- The printer may malfunction if left near a television, radio, etc. Do not use the printer near any device that will cause electromagnetic interference.
- Do not use the printer in any way or for any purpose not described in this manual. Doing so may result in accidents or damage to the printer.
- Do not put any foreign objects into the label outlet, AC adapter socket, USB port, serial port or LAN port (PT-9800PCN only), etc.
- Do not touch the print head with your fingers. Use the optional print head cleaning cassette (TZ-CL6), the self-cleaning function of the printer or a soft wipe (e.g. a cotton swab) when cleaning the print head. (→ P. 43)
- Do not clean the printer with alcohol or other organic solvents. Only use a soft, dry cloth.
- Do not place the printer in direct sunlight or rain, near heaters or other hot appliances, in any location exposed to extremely high or low temperatures (e.g. on the dashboard or in the back of your car), high humidity, or dusty locations. Standard operating temperature range: 10°C to 30°C.
- Do not leave any rubber or vinyl on the printer for an extended period of time, otherwise the printer may be stained.
- Depending on the environmental conditions and the applied settings, some characters or symbols may be difficult to read.
- Use only Brother TZ tapes or Brother HG tapes with this printer. Do not use tapes that do not have the  or  mark.
- Do not pull or apply pressure to the tape in the cassette. Otherwise the tape cassette or printer may be damaged.
- Do not try to print labels using an empty tape cassette or without a tape cassette set in the printer. Doing so will damage the print head.
- Do not attempt to cut the tape while printing or feeding since this will damage the tape.
- Be careful not to scratch the CD-ROM. Do not place the CD-ROM in any location exposed to high or low temperatures. Do not place heavy objects on the CD-ROM or bend it.
- The software on the CD-ROM is intended for use with the printer and may be installed on more than one computer.
- We strongly recommend that you read this User's Guide carefully before using your printer, and then keep it nearby for future reference.
- Depending on the location, material, and environmental conditions, the label may unpeel or become irremovable, the colour of the label may change or be transferred to other objects. Before applying the label, check the environmental condition and the material.
- Do not expose the tape cassettes to direct sunlight, high temperatures, high humidity, or dust. Store tape cassettes in a cool, dark place. Use the tape cassettes soon after opening the tape cassette package.
- Markings made with oil-based or water-based ink may be visible through a label affixed over them. To hide the markings, use two labels layered on top of each other or use a dark-coloured label.
- Note that Brother does not assume responsibility for any damage, etc. arising from failure to follow the precautions listed.

# Table of contents

<b>Unpacking the printer</b> .....	<b>7</b>
<b>General description</b> .....	<b>8</b>
LED lamps .....	9
<b>Getting ready to use your printer</b> .....	<b>11</b>
<b>Connecting the printer</b> .....	<b>12</b>
Connecting to the power source .....	12
Connecting to a computer .....	13
Using the interface cables .....	14
<b>Installing the tape cassette</b> .....	<b>15</b>
Authorised tape .....	15
Installing the tape cassette .....	15
<b>Installing the software for PT-9700PC</b> .....	<b>16</b>
When using Microsoft® Windows® .....	16
When using Mac OS® .....	18
<b>Installing the software for PT-9800PCN</b> .....	<b>20</b>
When using Microsoft® Windows® .....	20
When using Mac OS® .....	24
<b>Uninstalling the software</b> .....	<b>30</b>
When using Microsoft® Windows® .....	30
When using Mac OS® .....	31
<b>Advanced function</b> .....	<b>32</b>
Printing at a higher speed or at a higher resolution .....	32
Distributed printing .....	33
BTP (Bar code Template Print) function .....	35
Using P-touch Editor Lite LAN (PT-9800PCN and Windows® only) .....	40
Printing the printer settings .....	41
<b>Serial interface settings (Windows® only)</b> .....	<b>42</b>
Setting the computer baud rate .....	42
Setting the printer baud rate .....	42
<b>Maintenance</b> .....	<b>43</b>
<b>Troubleshooting</b> .....	<b>44</b>
Q & A .....	44
<b>Product specifications</b> .....	<b>47</b>
<b>Appendix</b> .....	<b>48</b>
General procedure for the BTP (Bar code Template Print) function .....	48
List of bar codes for specifying settings .....	49
<b>Index</b> .....	<b>52</b>

# Unpacking the printer

Open the box and confirm that the following items are included. If any item is missing or damaged, please contact your Brother dealer or Brother Customer Service.

## ■ PT-9700PC/PT-9800PCN

Printer (PT-9700PC)

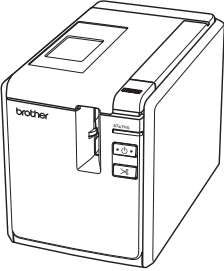

Printer (PT-9800PCN)

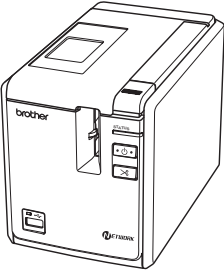

## ■ AC adapter (with adapter cord)

Connect to the power supply cord.

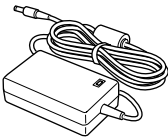

## ■ Power supply cord

Connect to the AC adapter and an electrical outlet (AC 220 to 240 V).

(The design of the AC power plug may differ by country.)



## ■ USB cable

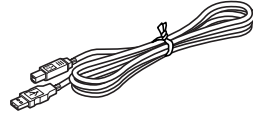

## ■ Tape cassette

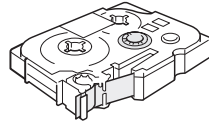

## ■ User's Guide

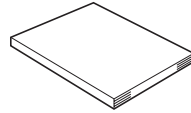

## ■ CD-ROM

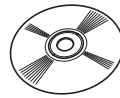

## ■ Tape catalogue

## General description

### ■ PT-9700PC

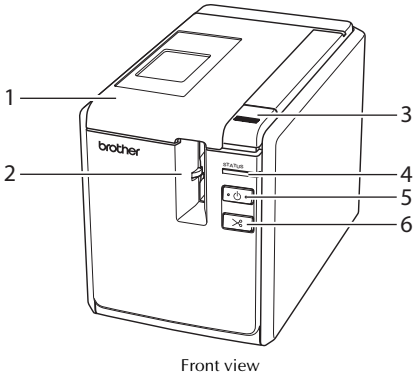

Front view

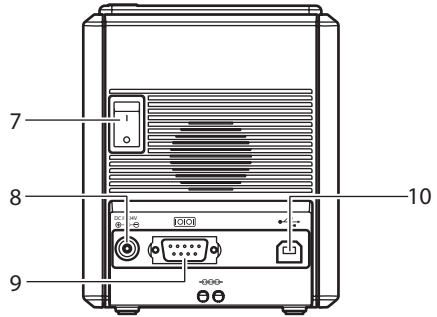

Rear view

### ■ PT-9800PCN

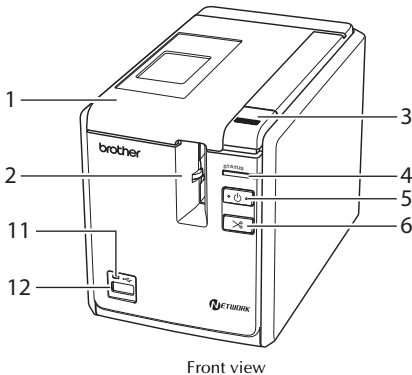

Front view

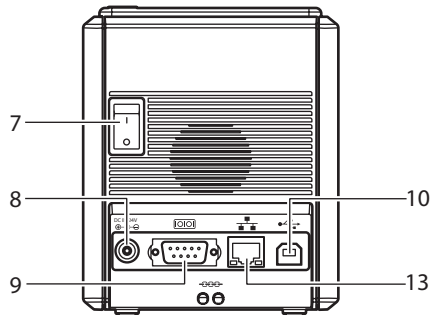

Rear view

1. Tape compartment cover
2. Label outlet
3. Cover release button
4. STATUS lamp
5. Power button (including lamp)
6. Feed/Cut button
7. Main power switch
8. AC adapter socket
9. Serial (RS-232C) port
10. USB port
11. LED lamp on USB Direct Interface (PT-9800PCN only)
12. USB Direct Interface for connecting a Bar code Reader (PT-9800PCN only)
13. LAN (10/100BASE-TX Wired Ethernet) port (PT-9800PCN only)

### Note

- If the tape compartment cover is left open, dust will collect on the print head. Always close the cover.

## LED lamps

The condition of the printer shown by LED lamps on printer or USB Direct Interface (PT-9800PCN only).

### ■ LED lamps on printer

Lamp condition		Condition	Remedy
Power lamp (green)	STATUS lamp (red)		
On	Off	Printer standby condition	—
Flashing	Off	Receiving data	—
Flashing	On	During the printer receiving data 1) No tape cassette 2) Tape compartment cover is open. 3) Incompatible tape cassette	1) Install the tape cassette and close the tape compartment cover. 2) Close the cover. 3) Install the correct tape cassette and close the tape compartment cover.
On	On	During the printer standby 1) No tape cassette 2) Tape compartment cover is open. 3) Incompatible tape cassette	1) Install the tape cassette and close the tape compartment cover. 2) Close the cover. 3) Install the correct tape cassette and close the tape compartment cover.
On	Flashing	During printing 1) No tape cassette 2) Tape compartment cover is open. 3) Incorrect tape cassette 4) Incompatible tape cassette	1) Install the tape cassette and close the tape compartment cover. 2) Close the cover. 3) Change the software setting or install the correct tape cassette. 4) Install the correct tape cassette and close the tape compartment cover.
		Empty tape cassette	Install a tape cassette containing tape and close the tape compartment cover.
		Transmission error	Press the power button on the front of the printer.

Lamp condition		Condition	Remedy
Power lamp (green)	STATUS lamp (red)		
On	Flashing fast	Cutter error	Confirm that the tape is not jammed in the printer. If necessary, turn the printer off and on with the power button. If the STATUS lamp continues to flash, contact your Brother dealer or Brother Customer Service.
		Roller holder error	
		Print head overheat error	
On	Flashing very fast	EEPROM error	Turn the printer off and on with the power button. If the STATUS lamp continues to flash, contact your Brother dealer or Brother Customer Service.
		Circuit board error	
Off	On	Booting	—

■ LED lamp on USB Direct Interface (PT-9800PCN only)

Lamp condition		Condition	Remedy
Colour	Condition		
—	Off	USB device not connected	—
Green	On	USB device connected	—
Red	Flashing	HUB connected	Disconnect the USB device.
	Flashing fast	Noncompliant USB device connected	Disconnect the USB device.
		"Buffer full" error with USB Direct Interface	Data sent from the bar code reader is saved on the printer. Do not use the bar code reader to consecutively scan bar codes and do not use the bar code reader with multiple interfaces at the same time.
Flashing very fast	Overcurrent	Disconnect the USB device and turn the printer off and on with the power button.	

# Getting ready to use your printer

Before creating labels with the printer, the following preparations are necessary.

## Note

- The connection procedures are different depending on the operating system running on the computer. They will also vary depending on whether a USB connection, serial connection or network connection (PT-9800 PCN only) is used. For details on connecting the printer to your specific computer, refer to "Connecting to a computer" (→ P.13).

### Connecting the printer

Connect the printer to the power source and your computer, and install a tape cassette. For details, refer to "Connecting the printer" (→ P.12) and "Installing the tape cassette" (→ P.15).

### Installing the software

You will need to install the printer driver to use your printer with your computer. You will also need to install P-touch Editor label design software. For details on installing this software, refer to "Installing the software for PT-9700PC" (→ P.16) or "Installing the software for PT-9800PCN" (→ P.20).

### Creating labels

After setting up your printer you can start creating labels. For details on how to design and create labels, refer to the "Software User's Guide" (PDF). For detailed feature explanations, you may also reference the P-touch Editor Help menu found in the software.

# Connecting the printer

Connect the printer to the power source and a computer.

## Connecting to the power source

- 1 Connect the included power supply cord to the AC adapter.

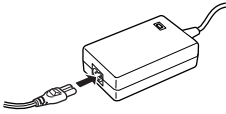

- 2 Insert the AC adapter connector into the AC adapter socket on the back of the printer.

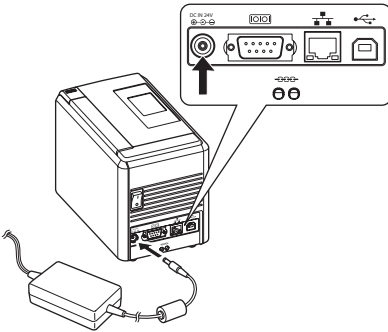

- 3 Plug the power supply cord into an electrical outlet (AC 220 to 240 V).

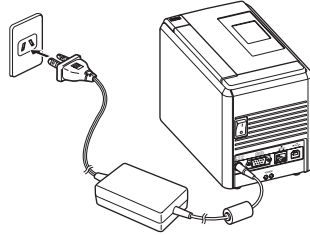

- 4 **Turning on the printer**  
Turn on the main power switch on the back of the printer, and then press the power button on the front of the printer.

### Turning off the printer

Hold down the power button on the front of the printer until the printer is turned off, and then turn off the main power switch on the back of the printer.

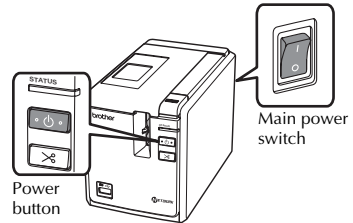

### Note

- Always turn the power off first using the power button on the front of the printer before removing the AC adapter or turning off the main power switch.
- After using the printer, disconnect the power supply cord from the electrical outlet and the AC adapter from the printer and store them for future use.
- When removing the AC adapter always pull the plug. Do not pull the AC adapter or power supply cord. The wire in the cords may break.
- Do not use any AC adapter other than the one included with the printer. Failure to observe this may result in an accident.

## Connecting to a computer

Connect the printer to a computer using the interface cables. The interface cables used to connect to a USB port, serial (RS-232C) port and LAN (10/100BASE-TX Wired Ethernet) port are different.

	Operation Systems	Basic Setup		Serial port (ESC/P and P-touch Template only)
		USB port	LAN port	
PT-9700PC	Windows® XP/ Windows Vista®/ Windows® 7	Yes	No	Yes
	Mac OS® X 10.3.9- 10.6			No
PT-9800PCN	Windows® XP/ Windows Vista®/ Windows® 7/ Windows Server® 2003/Windows Server® 2008/ 2008 R2	Yes	Yes	Yes
	Mac OS® X 10.3.9- 10.6			No

## Using the interface cables

Serial (RS-232C) cables and network (Ethernet) cables are not standard accessories. Use the appropriate cable for your type of interface.

### Note

- For USB interface, the included USB interface cable should be used to ensure compliance with the limits for EMC.
- For serial and network interfaces, a shielded interface cable should be used to ensure compliance with the limits for EMC.
- Changes or modifications not expressly approved by Brother Industries, Ltd. may affect the performance and print quality, and damage may not be covered under the limited warranty.

### ■ USB cable

Use the enclosed interface cable.

### ■ Serial (RS-232C) cable (Windows® only)

The pin assignments for the serial cables (RS-232C cables) which can be used with this printer are shown in the table below. You can purchase the cables at an electronics store. Do not use a serial cable that is longer than 1.8 m.

Brother printer side

(D-sub female, lock screw #4-40 inch screw)

Computer side

(D-Sub9P female)

Signal Name	Pin Number	Pin Assignments	Pin Number	Signal Name
DCD	1		1	DCD
RXD	2		2	RXD
TXD	3		3	TXD
DTR	4		4	DTR
GND	5		5	GND
DSR	6		6	DSR
RTS	7		7	RTS
CTS	8		8	CTS
RI	9		9	RI

### Note

- The RS-232C serial connector part of this equipment is not Limited Power Source.
- For details on serial interface settings, refer to "Serial interface settings (Windows® only)" (→ P.42).

### ■ Network cable (PT-9800PCN only)

Use a straight-through Category5 (or greater) twisted-pair cable for 10BASE-T or 100BASE-TX Fast Ethernet Network.

### Note

- Connect this product to a LAN connection that is not subjected to overvoltages.

## Installing the tape cassette

This section lists the types of tape that may be used with the printer and explains the procedures to install the tape cassettes.

### Authorized tape

The types of tape that may be used with the printer are listed below.

#### ■ TZ Tapes

- Standard Laminated Tape
- Standard Non-Laminated Tape
- Strong Adhesive Tape - Laminated
- Flexible ID tape - Laminated
- Fabric Iron-On Tape - Non-Laminated
- Security Tape - Laminated
- Stencil Tape - Non-Laminated

#### ■ HG Tapes

HG tapes enable three available combinations of higher printing speed and print resolutions. For details on high-speed printing, refer to "Printing at a higher speed or at a higher resolution" (→ P.32).

### Installing the tape cassette

This section explains the procedure to install the tape cassette.

- 1** Hold down the power button on the front of the printer until the Power lamp is off.
- 2** Press the cover release button and open the tape compartment cover.

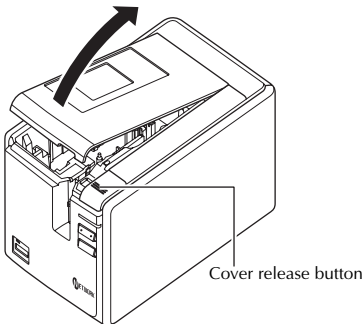

- 3** Install the tape cassette. Make sure that the end of the tape feeds under the tape guide.

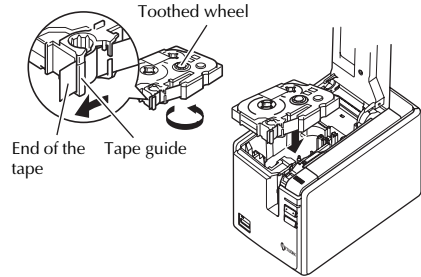

- If the ink ribbon is loose, use your finger to wind the toothed wheel in the direction of the arrow on the cassette.

- 4** Close the tape compartment cover and press the power button on the front of printer.

- 5** Press the Feed/Cut button to remove the tape slack.

#### Note

- You can only remove the tape cassette when the roller assembly of the printer has been released. It will be released automatically if you press the power button on the front of the printer or if no additional operation is performed within 10 minutes after printing a label.

# Installing the software for PT-9700PC

The procedure for installing the software varies depending on the OS of the computer. Installation procedure is subject to change without notice.

For Microsoft® Windows® users, see “When using Microsoft® Windows®” (→ P.16).  
For Macintosh® users, see “When using Mac OS®” (→ P.18).

## Note

- If you will be using the models “PT-9700PC”, it is necessary to install the following versions of P-touch Editor or b-PAC SDK to avoid printing difficulties:
  - [P-touch Editor] version 5.0.101 and later (included on CD).
  - [b-PAC SDK] version 3.0.010 and later (download from Brother Solutions Center).
- For details of the software, see the “Software User’s Guide” (PDF).
- You can find the “Software User’s Guide” (PDF) by clicking “Start” - “All Programs (Programs)” - “Brother P-touch” - “Manuals” - “PT-9700PC” - “Software User’s Guide”.

## When using Microsoft® Windows®

This section explains how to install P-touch Editor 5.0, the printer driver and Software User's Guide (PDF).

## Note

- Do not connect the printer to the computer until directed to do so.
- You must be logged on as a user with administrator privileges to install this software.
- Turn off the printer with the power button and then with the main power switch.

The following is the example for Windows Vista®.

- 1 Start the computer and put the CD-ROM into the CD-ROM drive.**

## Note

- If it does not start up automatically, open the files on the CD-ROM and double-click on “Setup.exe”.

- 2 Click [Standard Installation].**  
Installation items:

- Standard Installation**  
P-touch Editor 5.0, printer driver, and Software User’s Guide (PDF)
- Custom Installation**  
P-touch Editor 5.0, printer driver, and Software User’s Guide (PDF) can all be installed separately.

## Display User’s Guide

Software User’s Guide (PDF)  
(PDF reader software required)

## Adobe Reader Download

Link to the download page for Adobe® Reader® will be displayed.



- 3 Read the licence agreement and click [Yes] if you agree with the terms and conditions.**

Follow the on-screen instructions.

- 4 Put a check mark in the box next to the Add-In programs you want to install, and click [Next].**

With the Add-In feature you can use texts from those applications easily in our label layouts.

## Note

- Make sure that all Microsoft® Office applications are closed.

**5 Select the desired model, and then click [OK].**

Follow the on-screen instructions of the driver installation.

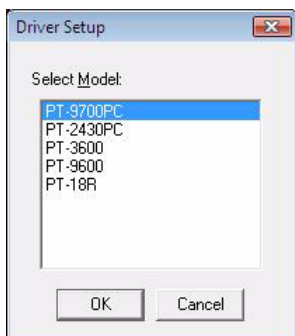

**6 When instructed, connect your printer to the computer by using the USB cable, and then turn on the printer.**

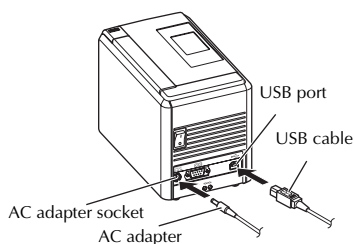

**7 Once the printer is detected, the driver will automatically be installed.**

**8 When instructed to register your printer online, select a registration method and click [Next].**

If you have selected to register the product online, your default internet browser will be launched in a new window. Follow the instructions to register your printer.

**9 When instructed to download the optional tools, select your choice and click [Next].**

- If you choose “Yes, display the page”, you will go to the Brother Solutions Center web site before finishing the installation (recommended). Choose your region (eg. Asia/Oceania), your country, your model and Downloads for your model.

- If you choose “No, do not display the page”, you will continue the installation.

**Note**

- To download the optional tools later, you can find them on this Web site: <http://solutions.brother.com/> Choose your region (eg. Asia/Oceania), your country, your model and Downloads for your model.

**10 Click [Finish].**  
The software installation is now complete. Restart your computer if you are instructed to do so.

**11 Start the software.**  
Click “Start” - “All Programs (Programs)” - “Brother P-touch” - “P-touch Editor 5.0” to start P-touch Editor 5.0.

## When using Mac OS®

This section explains how to install P-touch Editor 5.0 and the printer driver.

### Note

- Do not connect the printer to your Macintosh® before P-touch Editor 5.0 installation has been completed.
- You must be logged on as a user with administrator privileges to install this software.
- Turn off the printer with the power button and then with the main power switch.

Below is the example for Mac OS® X 10.5.7.

- 1** Start up the Macintosh®, and insert the CD-ROM into the CD-ROM drive. Double-click the “PT\_Series” (CD-ROM) icon.



- 2** Double-click “Brother PT-9700PC Driver.pkg” in the “Mac OS X” folder. The Driver Installer starts up. Follow the on-screen instructions.



- 3** After the installation is completed and the screen shown below is displayed, click [Close].

The installation of the printer driver is completed. Next, install the P-touch Editor 5.0.

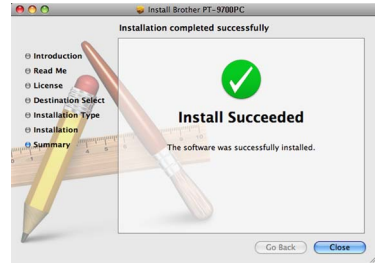

- 4** Double-click “P-touch Editor 5.0 Installer.mpkg”.

The P-touch Editor 5.0 Installer starts up. Follow the on-screen instructions.



- 5** When the installation is completed and the message “Click Restart to finish installing the software” is displayed, click [Restart].

The Macintosh® is restarted. The installation of software is completed.

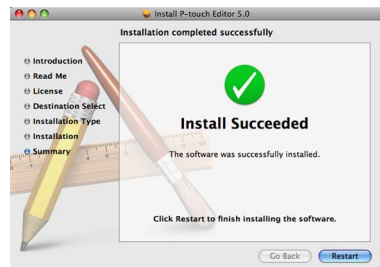

- 6** After restarting the Macintosh®, connect your printer to the Macintosh® by using the USB cable, and then turn on the printer.

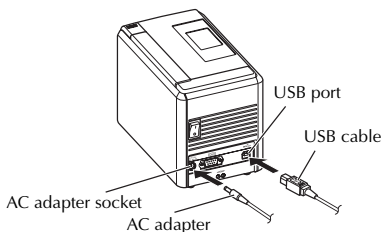

### Note

- If you are connecting the printer to the Macintosh® via a USB hub, it may not be detected correctly. If so, connect the printer directly to the USB port on the Macintosh®.

- 7** For Mac OS® X 10.3.9 - 10.4.x  
Double-click the drive where Mac OS® X is installed, and click “Applications” - “Utilities” - “Printer Setup Utility”.

#### For Mac OS® X 10.5.x - 10.6

Click Apple menu - “System Preferences”, and click “Print & Fax”.

- 8** For Mac OS® X 10.3.9 - 10.4.x  
Click [Add] and choose USB at the top of the screen.  
Choose “PT-9700PC” from the list and click [Add] again to add the printer to the “Printer List”.

#### For Mac OS® X 10.5.x - 10.6

Choose “Brother PT-9700PC” from the list and click [Add] /  to add the printer to the “Printer List” / “Print & Fax”.

- 9** When the screen returns to the “Printer List” / “Print & Fax” screen, check that the “PT-9700PC/Brother PT-9700PC” is added, and close the “Printer List” / “Print & Fax” screen.

Now you can use the printer.

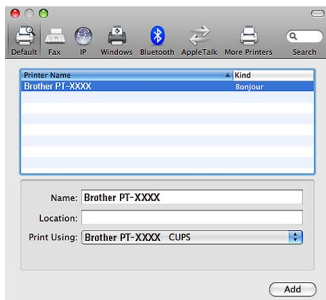

# Installing the software for PT-9800PCN

The procedure for installing the software varies depending on the OS of the computer. Installation procedure is subject to change without notice.

For Microsoft® Windows® users, see “When using Microsoft® Windows®” (→ P.20).  
For Macintosh® users, see “When using Mac OS®” (→ P.24).

## Note

- If you will be using the models "PT-9800PCN", it is necessary to install the following versions of P-touch Editor or b-PAC SDK to avoid printing difficulties:
  - [P-touch Editor] version 5.0.101 and later (included on CD).
  - [b-PAC SDK] version 3.0.010 and later (download from Brother Solutions Center).
- For details of the software, see the “Software User’s Guide” (PDF).
- For details of the Network, see the “Network User’s Guide” (PDF).
- You can find the Software User’s Guide or Network User’s Guide (PDF) by clicking “Start” - “All Programs (Programs)” - “Brother P-touch” - “Manuals” - “PT-9800PCN” - “Software User’s Guide” or “Network User’s Guide”.

## When using Microsoft® Windows®

This section explains how to install P-touch Editor 5.0, the printer driver, Software User’s Guide (PDF) and Network User’s Guide (PDF).

## Note

- **When using USB interface cable, do not connect the printer to the computer until directed to do so.**
- **You must be logged on as a user with administrator privileges to install this software.**
- **Turn off the printer with the power button and then with the main power switch.**

The following is the example for Windows Vista®.

- 1 Start the computer and put the CD-ROM into the CD-ROM drive.**

## Note

- If it does not start up automatically, open the files on the CD-ROM and double-click on “Setup.exe”.

- 2 Click [Standard Installation].**  
Installation items:

### □ Standard Installation

P-touch Editor 5.0, printer driver, Software User’s Guide (PDF), and Network User’s Guide (PDF)

### □ Custom Installation

P-touch Editor 5.0, printer driver, Software User’s Guide (PDF), Network User’s Guide (PDF), and P-touch Editor Lite LAN can all be installed separately.

### □ Utility Installation

BRAdmin Light  
How to install BRAdmin Light, see page 23.

### □ User’s Guide

Software User’s Guide (PDF), Network User’s Guide (PDF), and link to the download page for Adobe® Reader®.



- 3 Read the licence agreement and click [Yes] if you agree with the terms and conditions.**

Follow the on-screen instructions.

**4** Put a check mark in the box next to the Add-In programs you want to install, and click [Next].

With the Add-In feature you can use texts from those applications easily in our label layouts.

**Note**

- Make sure that all Microsoft® Office applications are closed.

**5** Then, choose your connection method and click [Next].

Connection method:

- Local Printer with USB cable**  
See “For USB interface cable users” (→ P.21).
- Brother Peer-to-Peer Network Printer**  
Check the LAN cable is connected to the printer.  
See “For network interface cable users” (→ P.22).
- Network Shared Printer**  
Check the LAN cable is connected to the printer.  
See “For shared network printer users” (→ P.22).

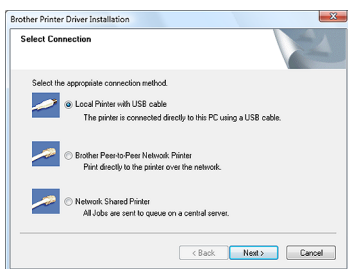

**Note**

- When using USB interface cable, do not connect the printer to the computer until directed to do so.

**■ For USB interface cable users**

**6** Follow the on-screen instructions. When this screen appears, confirm the printer is powered on. Connect the USB interface cable to your computer, and then connect it to the printer.

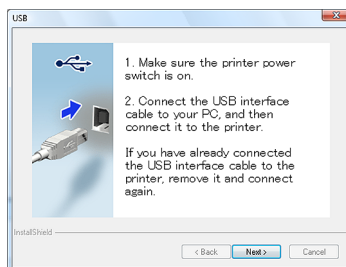

**7** When instructed to register your printer online, select a registration method and click [Next].

If you have selected to register the product online, your default internet browser will be launched in a new window. Follow the instructions to register your printer.

**8** When instructed to download the optional tools, select your choice and click [Next].

- If you choose “Yes, display the page”, you will go to the Brother Solutions Center web site before finishing the installation (recommended). Choose your region (eg. Asia/Oceania), your country, your model and Downloads for your model.
- If you choose “No, do not display the page”, you will continue the installation.

**Note**

- To download the optional tools later, you can find them on this Web site: <http://solutions.brother.com/>  
Choose your region (eg. Asia/Oceania), your country, your model and Downloads for your model.

**9** Click [Finish].  
The software installation is now completed. Restart your computer if you are instructed to do so.

**10** Start the software.  
Click “Start” - “All Programs (Programs)” - “Brother P-touch” - “P-touch Editor 5.0” to start P-touch Editor 5.0.

## ■ For network interface cable users

- 6** Choose “Search the network for devices and choose from a list of discovered devices (Recommended).” Or enter your printer’s IP address or its node name. Click [Next].

You can find your printer’s IP address and the node name by printing out the printer settings page. For details, refer to “Printing the printer settings” (→ P.41).

- 7** Choose your printer.  
Follow the on-screen instructions.

- 8** When instructed to register your printer online, select a registration method and click [Next].

If you have selected to register the product online, your default internet browser will be launched in a new window. Follow the instructions to register your printer.

- 9** When instructed to download the optional tools, select your choice and click [Next].

- If you choose “Yes, display the page”, you will go to the Brother Solutions Center web site before finishing the installation (recommended). Choose your region (eg. Asia/Oceania), your country, your model and Downloads for your model.
- If you choose “No, do not display the page”, you will continue the installation.

### Note

- To download the optional tools later, you can find them on this Web site: <http://solutions.brother.com/> Choose your region (eg. Asia/Oceania), your country, your model and Downloads for your model.

- 10** Click [Finish].  
The software installation is now completed.  
Restart your computer if you are instructed to do so.

- 11** Start the software.  
Click “Start” - “All Programs (Programs)” - “Brother P-touch” - “P-touch Editor 5.0” to start P-touch Editor 5.0.

## ■ For shared network printer users

- 6** Choose your printer’s queue, and then click [OK].  
Follow the on-screen instructions.

### Note

- Contact your administrator if you do not know the location or the name of the printer in the network.

- 7** When instructed to register your printer online, select a registration method and click [Next].

If you have selected to register the product online, your default internet browser will be launched in a new window. Follow the instructions to register your printer.

- 8** When instructed to download the optional tools, select your choice and click [Next].

- If you choose “Yes, display the page”, you will go to the Brother Solutions Center web site before finishing the installation (recommended). Choose your region (eg. Asia/Oceania), your country, your model and Downloads for your model.
- If you choose “No, do not display the page”, you will continue the installation.

### Note

- To download the optional tools later, you can find them on this Web site: <http://solutions.brother.com/> Choose your region (eg. Asia/Oceania), your country, your model and Downloads for your model.

- 9** Click [Finish].  
The software installation is now completed.  
Restart your computer if you are instructed to do so.

- 10** Start the software.  
Click “Start” - “All Programs (Programs)” - “Brother P-touch” - “P-touch Editor 5.0” to start P-touch Editor 5.0.

## ■ Installing the BRAdmin Light configuration utility

The BRAdmin Light is a utility for initial setup of Brother network connected devices. It can also search for Brother products on your network, view the status and configure basic network settings, such as IP address. For more information on BRAdmin Light, visit us at <http://solutions.brother.com/>

### Note

- If you require more advanced printer management, use the latest Brother BRAdmin Professional utility version that is available as a download from <http://solutions.brother.com/>
- If you are using personal firewall software, BRAdmin Light may fail to detect the unconfigured device. In that case, disable your personal firewall software, and try using BRAdmin Light again. Restart your personal firewall software after the address of the unconfigured device is set.

### 1 Click [Utility Installation].

This screen is the same screen as you see when you insert the CD-ROM.



### 2 Click [BRAdmin Light] and follow the on-screen instructions.



If the Windows Firewall is enabled on your computer, the message "Do you wish to add this application to the list of exceptions?" appears. Check your computer environment and choose [Yes] or [No].



## ■ Setting your IP address, Subnet Mask and Gateway using BRAdmin Light

### 1 Click "Start"->"All Programs (Programs)"->"Brother"->"BRAdmin Light".

BRAdmin Light will search for new devices automatically.

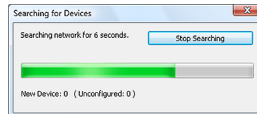

### Note

- If you have a DHCP/BOOTP/RARP server in your network, you don't have to do the following operation, because the print server will automatically obtain its IP address.

### 2 Double-click the unconfigured device.

The default password is "access".

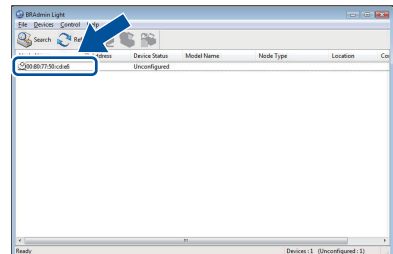

- 3** Choose **STATIC** for the Boot Method. Enter the IP Address, Subnet Mask and Gateway, and then click [OK].

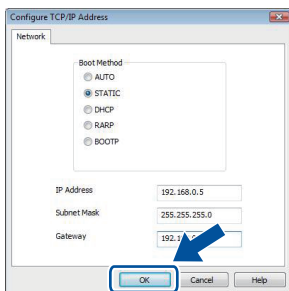

- 4** The address information will be saved to the printer.

## When using Mac OS®

This section explains how to install P-touch Editor 5.0 and printer driver.

### Note

- Do not connect the printer to your Macintosh® before P-touch Editor 5.0 installation has been completed.
- You must be logged on as a user with administrator privileges to install this software.
- Turn off the printer with the power button and then with the main power switch.

The screens are from Mac OS® X 10.5.7.

- 1** Start up the Macintosh®, and insert the CD-ROM into the CD-ROM drive. Double-click the "PT\_Series" (CD-ROM) icon.



PT\_Series

- 2** Double-click "Brother PT-9800PCN Driver.pkg" in the "Mac OS X" folder. The Driver Installer starts up. Follow the on-screen instructions.



Brother PT-9800PCN  
Driver.pkg

- 3** After the installation is completed and the screen shown below is displayed, click [Close].

The installation of the printer driver is completed.

Next, install the P-touch Editor 5.0.

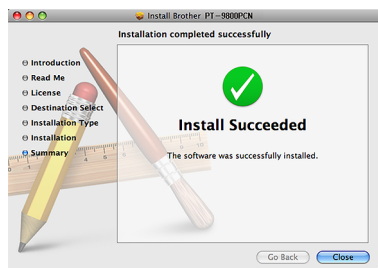

- 4** Double-click "P-touch Editor 5.0 Installer.mpkg".

The P-touch Editor 5.0 Installer starts up. Follow the on-screen instructions.



P-touch Editor 5.0  
Installer.mpkg

- 5** When the installation is completed and the message "Click Restart to finish installing the software" is displayed, click [Restart].

The Macintosh® is restarted.

The installation of software is completed.

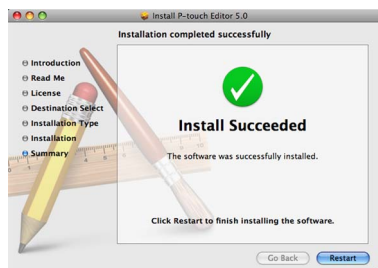

- 6** After restarting the computer, connect your printer to the computer by using the USB/LAN cable, and then turn on the printer.

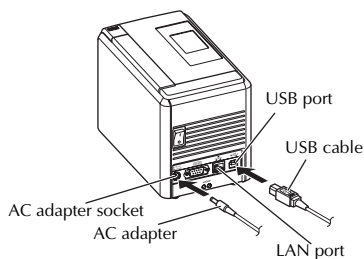

### Note

- If you are connecting the printer to the Macintosh® via a USB hub, it may not be detected correctly. If so, connect the printer directly to the USB port on the Macintosh®.

- 7** For Mac OS® X 10.3.9 - 10.4.x

Double-click the drive where Mac OS® X is installed, and click "Applications" - "Utilities" - "Printer Setup Utility".

### For Mac OS® X 10.5.x - 10.6

Click Apple menu - "System Preferences", and click "Print & Fax". Then click  to add your printer.

## 8 Choose your connection method.

### □ Local Printer with USB cable

See “For USB interface cable users” (→ P.26).

### □ Network Shared Printer (Simple network configuration)

Check the LAN cable is connected to the printer.

See “For network interface cable users (Simple network configuration)” (→ P.27).

### □ Network Shared Printer (Manual network configuration)

Check the LAN cable is connected to the printer.

See “For network interface cable users (Manual network configuration)” (→ P.28).

## ■ For USB interface cable users

### 9 For Mac OS® X 10.3.9

Click [Add] and choose “USB” at the top of the screen.

Choose “PT-9800PCN” from the list and click [Add] again to add the printer to the “Printer Setup Utility”.

### For Mac OS® X 10.4.x - 10.6

Click [Add] / [+].

Choose “PT-9800PCN/Brother PT-9800PCN” from the list and click [Add] to add the printer to the “Printer Setup Utility”/“Print & Fax”.

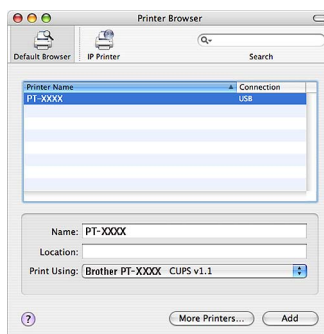

### Note

- For Mac OS® X 10.4.x, click [Add] and add the printer with the BRPTUSB connection. (If you do so, an error dialog appears when an printing error occurs.) Set the appropriate printer name.

### 10 When the screen returns to the “Printer List” / “Print & Fax” screen, check that the “PT-9800PCN/Brother PT-9800PCN” is added, and close the “Printer List” / “Print & Fax” screen.

Now you can use the printer.

### Note

- For details on software, see the P-touch Editor Help.

■ For network interface cable users  
(Simple network configuration)

9 Click [Add].

10 For Mac OS® X 10.3.9  
Make the selection shown below.

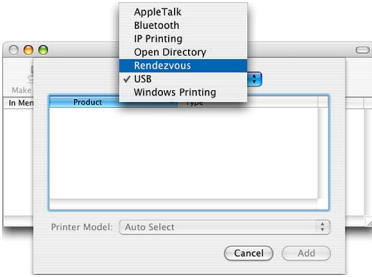

11 Choose "Brother PT-9800PCN" from the list and click [Add] again to add the printer to the "Printer Setup Utility"/ "Print & Fax".

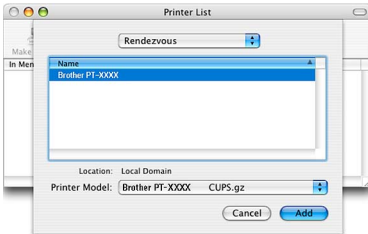

Mac OS® X 10.3.9

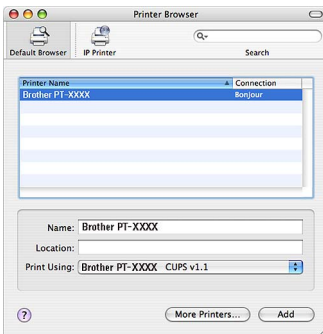

Mac OS® X 10.4.x

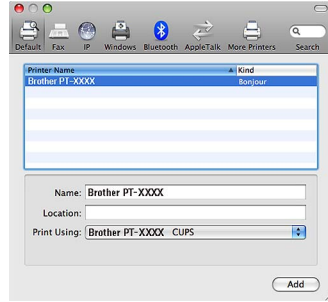

Mac OS® X 10.5.x-10.6

12 When the screen returns to the "Printer List" / "Print & Fax" screen, check that the "Brother PT-9800PCN" is added, and close the "Printer List" / "Print & Fax" screen.

Now you can use the printer.

**Note**

- For details on software, see the P-touch Editor Help.

## ■ For network interface cable users (Manual network configuration)

- 9** For Mac OS® X 10.3.9  
Click [Add] and choose IP Printing at the top of the screen.  
Enter the IP address of the printer into the Printer Address box. Choose “PT-9800PCN” from the list and click [Add] again to add the printer to the “Printer Setup Utility”.

### For Mac OS® X 10.4.x - 10.6

Click [Add] and choose IP Printer / IP at the top of the screen.  
Enter the IP address of the printer into the Address box. Choose “Brother PT-9800PCN” from the list and click [Add] again to add the printer to the “Printer Setup Utility”.

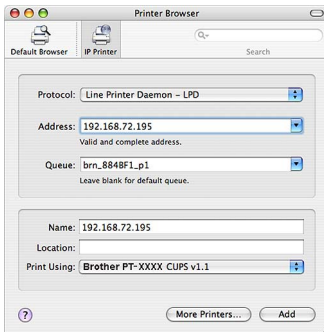

### Note

- When specifying the Queue Name, choose the value BRNxxxxxxxxxxxx (where xxxxxxxxxxxx is the Ethernet address).

- 10** When the screen returns to the “Printer List” / “Print & Fax” screen, check that the “Brother PT-9800PCN” is added, and close the “Printer List” / “Print & Fax” screen.  
Now you can use the printer.

### Note

- For details on software, see the P-touch Editor Help.

## ■ Installing the BRAdmin Light configuration utility

The BRAdmin Light is a utility for initial setup of Brother network connected devices. It can also search for Brother products on your network, view the status and configure basic network settings, such as IP address. For more information on BRAdmin Light, visit us at <http://solutions.brother.com/>

### Note

- If you are using personal firewall software, BRAdmin Light may fail to detect the unconfigured device. In that case, disable your personal firewall software, and try using BRAdmin Light again. Restart your personal firewall software after the address of the unconfigured device is set.

- 1** Double-click “BRAdmin Light.pkg” in the “Mac OS X” folder.

The BRAdmin Light Installer starts up. Follow the on-screen instructions.



BRAdmin Light.pkg

- 2** When the installation is completed and the message “The Software was successfully installed.” is displayed, click [Close].

The installation of BRAdmin Light is completed.

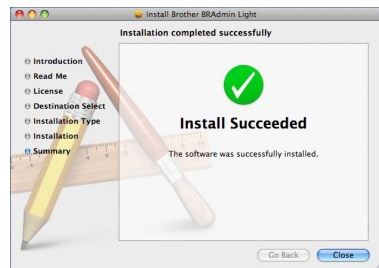

## ■ Setting your IP Address, Subnet Mask and Gateway using BRAdmin Light

- 1 Click “Library”-“Printers”-“Brother”-“P-touch Utilities”-“BRAdmin Light.jar”. BRAdmin Light will search for new devices automatically.



BRAdmin Light.jar

### Note

- If you have a DHCP/BOOTP/RARP server in your network, you don't have to do the following operation, as the print server will automatically obtain its IP address.

- 2 Double-click the unconfigured device. The default password is “access”.

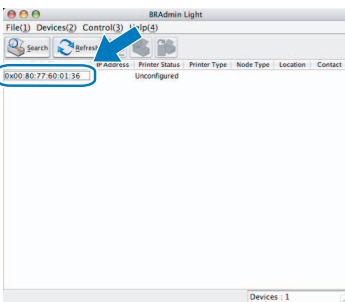

- 3 Choose “STATIC” for the “BOOT Method”. Enter the IP Address, Subnet Mask and Gateway, and then click [OK].

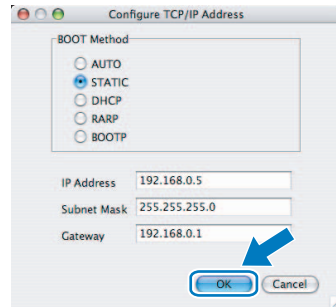

- 4 The address information will be saved to the printer.

# Uninstalling the software

This section describes how to uninstall the software and printer driver. In the following steps, you will see PT-XXXX. Read “XXXX” as your printer name.

For Microsoft® Windows® users, see “When using Microsoft® Windows®” (→ P.30).

For Macintosh® users, see “When using Mac OS®” (→ P.31).

## When using Microsoft® Windows®

### ■ Uninstalling P-touch Editor

- 1 For Windows® XP**  
From the “Control Panel”, go to “Add or Remove Programs”.  
The “Add or Remove Programs” window appears.

**For Windows Vista®/Windows® 7**  
From the “Control Panel”, go to “Programs” and open “Programs and Features”.  
The “Uninstall or change a program” window appears.

- 2 For Windows® XP**  
Choose “Brother P-touch Editor 5.0”, and click [Remove].

**For Windows Vista®/Windows® 7**  
Choose “Brother P-touch Editor 5.0”, and click [Uninstall].  
When the “User Account Control” dialog box appears, click [Continue]. If a password is requested, type in the password, and then click [OK].

- 3 Click [OK].**  
After the software is removed from your computer, the “Maintenance Complete” dialog box appears. Click [Finish].

- 4 Close the “Add or Remove Programs (XP) / Programs and Features (Windows Vista® / Windows® 7)” window.**  
The P-touch Editor has been uninstalled.

#### Note

- Software User’s Guide (PDF) and Network User’s Guide (PDF) (PT-9800PCN only) can also be uninstalled by following the same procedure.

### ■ Uninstalling the printer driver

- 1 Turn off the printer.**
- 2 For Windows® XP**  
From the “Control Panel”, open the “Printers and Faxes” window.  
**For Windows Vista®**  
From the “Control Panel”, go to “Hardware and Sound” and open “Printers”.  
**For Windows® 7**  
Click the , go to [Devices and Printers].

#### Note

- For details, see Windows® Help.

- 3 For Windows® XP**  
Choose “Brother PT-XXXX”, and click “File”-“Delete” or right click on the icon and then click [Delete].  
**For Windows Vista®/Windows® 7**  
Choose “Brother PT-XXXX”, and click [Delete this printer] or right click on the icon, and then click [Delete] (Windows Vista®)/ [Remove device] (Windows® 7).

- 4 For Windows® XP**  
Go to “File”-“Server Properties”.  
The “Print Server Properties” window appears.  
**For Windows Vista®**  
In the “Printers” window, right click and select “Run as administrator”-“Server Properties...”.  
If the authorization confirmation dialog appears, click [Continue].  
If the “User Account Control” dialog appears, enter the password and click [OK].  
The “Print Server Properties” window appears.  
**For Windows® 7**  
Choose [Fax] or [Microsoft XPS Document Writer] in the [Devices and Printers] window, and then click [Print server properties], which appeared in the menu bar.

- 5 For Windows® XP**  
Click the “Drivers” tab and choose “Brother PT-XXXX”. Then, click [Remove].  
Go to step **7**.

**For Windows Vista®**

Click the “Drivers” tab and choose “Brother PT-XXXX”. Then, click [Remove...].

**For Windows® 7**

Click the [Drivers] tab, and then click [Change Driver Settings].  
(If a User Account Control message appears, type in the password, and then click [OK].)  
Choose “Brother XX-XXXX”, and then click [Remove...].

- 6 For Windows® XP**  
Go to step **7**.

**For Windows Vista®**

Choose [Remove driver only] and click [OK].

**For Windows® 7**

Choose [Remove driver and driver package], and then click [OK].

- 7 Close the “Print Server Properties” window.**

The printer driver has been uninstalled.

---

## When using Mac OS®

---

### ■ Uninstalling P-touch Editor

- 1 On the drive where P-touch Editor is installed, double-click the “Applications” folder - “P-touch Editor 5.0” folder - “Uninstall P-touch” folder - “UninstallPtEditor.command”.**

The “Terminal” window appears, and the uninstall operation starts.

#### Note

- Administrator privileges are required for the uninstall operation.
- In case the “Terminal” window does not appear by double-clicking the “UninstallPtEditor.command”, right click (or press control key + click) the “UninstallPtEditor.command”. The context menu appears. Open the “Terminal” window from the context menu.

- 2** Click  to close the “Terminal” window.
- 3** Delete “Applications”-“P-touch Editor 5.0” folder.

#### Note

- Before you delete the “P-touch Editor 5.0” folder, please check if any necessary files are saved in it.

P-touch Editor has been uninstalled.

### ■ Uninstalling the printer driver

- 1 Turn off the printer.**
- 2 For Mac OS® X 10.3.9 - 10.4.x**  
Double-click the drive where Mac OS® X is installed, and click “Applications” - “Utilities” - “Printer Setup Utility”. The “Printer List” window appears.
- For Mac OS® X 10.5.x - 10.6**  
Click Apple menu - “System Preferences”, and click “Print & Fax”.

- 3 For Mac OS® X 10.3.9 - 10.4.x**  
Choose “PT-XXXX”, and click .

**For Mac OS® X 10.5.x - 10.6**  
Choose “Brother PT-XXXX”, and click .

- 4 Close the “Printer List” / “Print & Fax” window.**  
The printer driver has been uninstalled.

## Advanced function

After the printer has been connected to the computer, labels can be created and printed. This section describes various useful print settings and how to use a bar code reader to print labels without a computer.

### ■ Printing labels at high speed or a high resolution

See “Printing at a higher speed or at a higher resolution” (→ P.32)

### ■ Printing a large number of labels distributed to multiple printers

See “Distributed printing” (→ P.33)

### ■ Printing using only a bar code reader without a computer

See “BTP (Bar code Template Print) function” (→ P.35)

### ■ Creating and printing simple labels by using P-touch Editor Lite LAN (PT-9800PCN only)

See “Using P-touch Editor Lite LAN (PT-9800PCN and Windows® only)” (→ P.40)

### ■ Printing a list of the current printer settings

See “Printing the printer settings” (→ P.41)

## Printing at a higher speed or at a higher resolution

The print speed and resolution can be changed depending on the combination of the type of tape being used and the selected output setting. With HG tape, labels can be printed at an even faster speed or higher resolution.

Output	Tape Type		Resolution
	TZ tape	HG tape	
High Speed (HG only)	—	80 mm/sec	360 × 180 dpi
Standard	20 mm/sec	52 mm/sec	360 × 360 dpi
High Resolution (HG Only)	—	20 mm/sec	360 × 720 dpi

- When HG tape is used, printing can be performed at a faster speed or at a higher resolution than with TZ tape.
- When HG tape is used with the “High Speed” setting selected, printing can be performed even faster. However, since the resolution in the feed direction is reduced, this is not suitable for detailed printing.
- When HG tape is used with the “High Resolution” setting selected, printing can be performed with an even higher resolution. This is suitable for detailed printing of objects such as graphics and curved lines.
- When printing bar codes, use the “Standard” setting, which has identical horizontal and vertical resolutions.

### Note

- The print speeds listed above indicate the highest speeds possible. The actual speed may differ depending on the operating conditions.

## Distributed printing

When printing a large number of labels, printing can be distributed among multiple printers.

Since printing is performed at the same time, the total printing time can be reduced.

### Note

- Printing can be distributed to printers connected via a USB connection or network connection (PT-9800PCN only).
- The number of pages to be printed is automatically divided among the selected printers. If the specified number of pages cannot be evenly divided among the printers, it will be divided in the order of the printers listed in the “Distributed Printing Settings” dialog box when the print settings are specified in step 4.

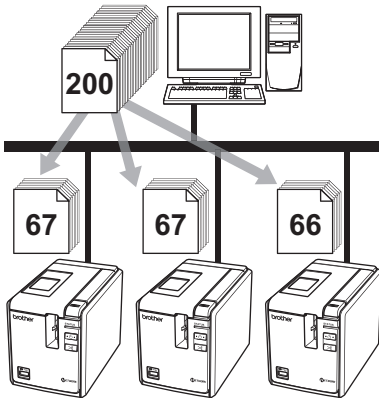

1 From the “File” menu in P-touch Editor 5.0, click “Print”.

2 Click [Properties...].

3 Select the “Advanced” tab, select the “Distributed printing” check box, and then click [Settings].

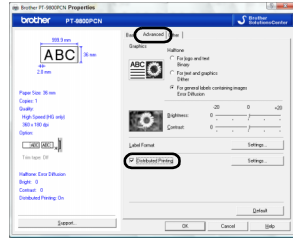

4 In the “Distributed Printing Settings” dialog box, select the printers to be used for distributed printing.

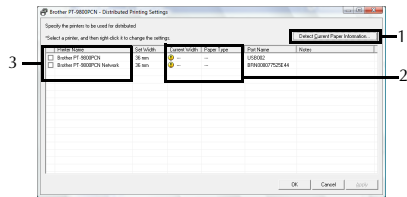

1. Click [Detect Current Paper Information].
2. The current printer information that was detected appears below “Current Width” and “Paper Type”.
3. Select the check box beside the “Printer Name” to be used for distributed printing.

**5 Specify the tape width to be used for printing.**

**A.If only one printer has been selected**

In the dialog box from step 4, select the printer whose setting is to be specified, and then either double-click it or right-click it and click “Settings”. From the “Set Width” drop-down list, select the tape width.

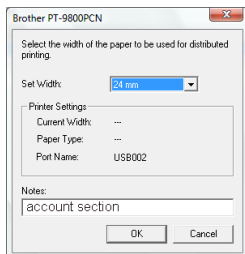

**Note**

- Information to be displayed in the dialog box from step 4 can be entered in the “Notes” text box.

**B.If multiple printers have been selected**

In the dialog box from step 4, select the printers whose setting are to be specified, and right-click them and click “Settings”. From the “Set Width” drop-down list, select the tape width. The same tape width setting is applied to all selected printers.

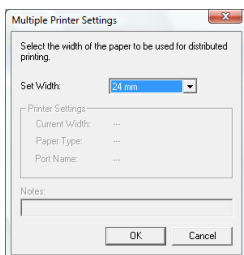

**Note**

- The settings below “Printer Settings” and “Notes” are not available.

**6 Click [OK] to close the tape width setting window.**

**7 Click [OK] to close the “Distributed Printing Settings” window.**  
Setup is completed.

**8 Click [OK] to start distributed printing.**

**Note**

- If the selected tape width is different from that displayed beside “Current Width”, a warning icon appears beside the setting below “Current Width”. Load the printer with tape of the width specified with “Set Width”.
- It may be impossible to detect information for a printer connected using the PS-9000 or any common USB hub or print server. Before printing, enter the settings manually, and check if the printer can be used for printing.
- Depending on whether a router is used and the security features in use, such as a firewall, it may not be possible to use this function.
- We recommend performing a connection test for your operating environment. For more information, contact a sales representative.

## BTP (Bar code Template Print) function

With a bar code reader connected to the printer, labels and bar codes can be easily printed without a computer by scanning bar codes.

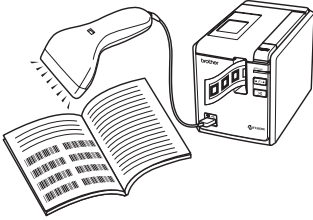

### ❑ Preset template printing (→ P.36)

If a frequently used label layout is transferred to the printer, identical labels can be printed simply by scanning the print settings and commands with a bar code reader.

### ❑ Bar code printing (→ P.37)

A bar code scanned with the bar code reader can be printed with the protocol and with the size from a previously created template.

### ❑ Database-assisted label printing (→ P.38)

An object in a P-touch Editor label layout which is connected with a database can be replaced with bar code data scanned by the bar code reader.

## ■ Preparation

Connect a bar code reader to the printer.

### ❑ Bar code reader connection interfaces

	Bar code reader	
	RS-232	USB direct interface
PT-9700PC	Yes	No
PT-9800PCN	Yes	Yes

### ❑ Bar code reader models whose operation has been confirmed

- OPR-4001 (OPTOELECTRONICS CO., LTD.)
- LS-1203 (Motorola, Inc.)
- DS 6707 (Honeywell International Inc.)

## Note

- For the FAQ and up-to-date list of bar code reader models whose operation has been confirmed, visit the Brother Solutions Center (<http://solutions.brother.com/>).
- Before this function can be used, the label layout or template to be used must be transferred with the Transfer Manager from the computer to the printer. For details of the Transfer Manager, see the “Software User’s Guide” (PDF).
- The bar code reader should be set for bar codes with no prefix or suffix.
- Various settings such as the baud rate must be changed in order to use the RS-232C connection. For details on changing the settings, refer to the operation manual for the bar code reader. The default settings for the serial port of this printer are listed below.

Baud rate	9600bps	Flow control	DTR
Parity	None	Stop bit	1
Bit length	8		

- To change the printer serial interface communications settings, refer to “Serial interface settings (Windows® only)” (→ P.42) for detailed information.
- For details on using the bar code reader, contact the manufacturer.

## ■ Preset template printing

If a frequently used label layout is stored in the printer, identical labels can be easily printed without a computer by scanning bar codes.

<Name label>

Bill Anderson

<Address label>

Mr. Bill Anderson  
4555 Cumberland Pkwy  
Anytown USA 95063

### Note

- For details on the various settings that can be chosen by scanning the appropriate bar code, refer to “List of bar codes for specifying settings” (→ P.49).

## 1 Transfer the label layout to be printed from the P-touch Editor 5.0 to the printer by using the Transfer Manager. (See Software User’s Guide.)

### Note

- A text object in the label layout can be converted to an image. After being converted to an image, the text cannot be changed. This is useful for protecting frequently used templates from being accidentally edited.  
In the P-touch Editor layout window, right-click the text object, and then click “Properties”. Click the “Expanded” tab, and then select the “Text Cannot Be Edited” check box.  
If you cannot see the “Expanded” tab, click “Options” in the “Tools” menu, click the “General” tab, and then select the “Display Expanded Tabs of Object Properties” check box under “Others”. When the check box is cleared, the object is converted back to text that can be edited.

## 2 When data is transferred to “Configurations” in Transfer Manager, the “Key Assign” number is automatically specified.

### Note

- Specify a “Key Assign” number between 1 and 10 for label layouts to be used with preset template printing.

## 3 Scan the “P-touch template command” bar code to begin specifying the print settings.

Refer to “List of bar codes for specifying settings” (→ P.49).

## 4 Specify the print settings by scanning the bar codes with the desired settings, from the “Basic Settings” bar codes.

### Note

- It is possible to scan multiple settings.
- If no settings have been specified, a label will be printed with the default P-touch Template Setting (Single copy with “Auto cut on” and “Half cut on”). For details on P-touch Template Settings, download “P-touch Template manual” (English only) from the following web site.  
<http://solutions.brother.com/>  
Choose your region (eg. Asia/Oceania), your country, your model and Downloads for your model.
- To specify the number of copies to be printed, scan the “Number of copies” bar code, and then scan the bar codes under “For entering numbers” to specify a three-digit number.  
Example:  
Specify numbers by scanning bar codes as follows: 7→[00][7], 15→[0][1][5]
- To change the setting for the number of copies, scan the “Number of copies” bar code again, and then scan the bar codes for the new three-digit number.

## 5 Scan the bar code under “Preset template number” with the same number as the “Key Assign” number for the label layout to be printed.

## 6 The specified label is printed.

## ■ Bar code printing

A bar code scanned with the bar code reader can be printed with the protocol and size from a previously created template.

### Note

- For details on the various settings that can be chosen by scanning the appropriate bar code, refer to “List of bar codes for specifying settings” (→ P.49).
- If the bar code to be scanned with the bar code reader has a different protocol than the bar code in the previously created template, it may not be possible to create and print the bar code.

- 1 Transfer the template to be printed from the P-touch Editor 5.0 to the printer by using the Transfer Manager. (See Software User’s Guide.)**

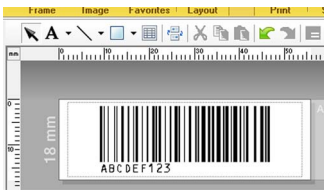

(CODE128/9-digit/69 mm×17 mm)

### Note

- Be sure to create bar code templates that comply with the limits on the size and number of digits for the bar code to be scanned. The new bar code cannot be created if it exceeds the number of digits specified in the template.

- 2 When data is transferred to “Configurations” in Transfer Manager, the “Key Assign” number is automatically specified.**

- 3 Scan the “P-touch template command” bar code to begin specifying the print settings.**  
Refer to “List of bar codes for specifying settings” (→ P.49).

- 4 Specify the print settings by scanning the bar codes with the desired settings, from the “Basic Settings” bar codes.**

### Note

- It is possible to scan multiple settings.
- If no settings have been specified, a label will be printed with the default P-touch Template Setting (Single copy with “Auto cut on” and “Half cut on”). For details on P-touch Template Settings, download “P-touch Template manual” (English only) from the following web site.  
<http://solutions.brother.com/>  
Choose your region (eg. Asia/Oceania), your country, your model and Downloads for your model.
- To specify the number of copies to be printed, scan the “Number of copies” bar code, and then scan the bar codes under “For entering numbers” to specify a three-digit number. The setting is automatically applied when three digits have been specified.

Example:

Specify numbers by scanning bar codes as follows: 7→[00][7], 15→[0][1][5]

- To change the setting for the number of copies, scan the “Number of copies” bar code again, and then scan the bar codes for the new three-digit number.

- 5 Scan the “Select template” bar code, and then scan the bar codes under “For entering numbers” to specify the “Key Assign” number (three digits) for the bar code template.**

### Note

- The setting is automatically applied when three digits have been specified.  
Example:  
Specify numbers by scanning bar codes as follows: 7→[00][7], 15→[0][1][5]
- To change the number, scan the “Select template” bar code again, and then scan the bar codes for the new three-digit number.

- 6 Scan the bar code whose data is to be used.



(CODE128/9-digit)

- 7 Scan the “Bin printing” bar code.

- 8 The bar code is printed with the protocol and size specified in the template.



### ■ Database-assisted label printing

First, a database field must be connected to an object in the label layout. Then, when a key bar code is scanned with the bar code reader, the bar code data can be printed replacing data from the connected database file in the object of the specified template.

#### Note

- The key bar code is the bar code for the information appearing in the database file at the leftmost column in record view (field “A” in form view). These key bar codes must be created in advance.
- The database information in field “A” of the form view must not include any other data. In addition, even if the information contains two lines of data, only the first line of data is recognised when the bar code is scanned with the bar code reader. Therefore, enter only one line of data into the information in field “A” of the form view.
- For details on the various settings that can be chosen by scanning the appropriate bar code, refer to “List of bar codes for specifying settings” (→ P.49).

- 1 Connect the database file to the label layout to be printed.

For details on specifying the settings, refer to the “P-touch Editor Help”.

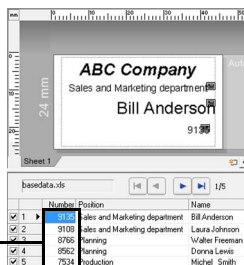

Data to be replaced by the key bar code data

- 2 Transfer the label layout to be printed from the P-touch Editor 5.0 to the printer by using the Transfer Manager. (See Software User’s Guide.)

The database file is also transferred.

- 3 When data is transferred to “Configurations” in Transfer Manager, the “Key Assign” number is automatically specified.

- 4 Scan the “P-touch template command” bar code to begin specifying the print settings.

Refer to “List of bar codes for specifying settings” (→ P.49).

- 5 Specify the print settings by scanning the bar codes with the desired settings, from the “Basic Settings” bar codes.

## Note

- It is possible to scan multiple settings.
- If no settings have been specified, a label will be printed with the default P-touch Template Setting (Single copy with “Auto cut on” and “Half cut on”). For details on P-touch Template Settings, download “P-touch Template manual” (English only) from the following web site.  
<http://solutions.brother.com/>  
Choose your region (eg. Asia/Oceania), your country, your model and Downloads for your model.
- To specify the number of copies to be printed, scan the “Number of copies” bar code, and then scan the bar codes under “For entering numbers” to specify a three-digit number. The setting is automatically applied when three digits have been specified.  
Example:  
Specify numbers by scanning bar codes as follows: 7→[00][7], 15→[0][1][5]
- To change the setting for the number of copies, scan the “Number of copies” bar code again, and then scan the bar codes for the new three-digit number.

- 6** Scan the “Select template” bar code, and then scan the bar codes under “For entering numbers” to specify the “Key Assign” number (three digits) for the bar code template.

## Note

- The setting is automatically applied when three digits have been specified.  
Example:  
Specify numbers by scanning bar codes as follows: 7→[00][7], 15→[0][1][5]
- To change the number, scan the “Select template” bar code again, and then scan the bar codes for the new three-digit number.

- 7** Scan the key bar code whose data is to be used in the database file.



- 8** Scan the “Delimiter” bar code.

- 9** Scan the “Begin printing” bar code.

- 10** The object data in the specified template is replaced with the database data, and the labels are printed.

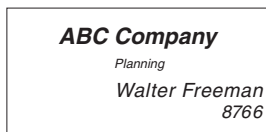

## Using P-touch Editor Lite LAN (PT-9800PCN and Windows® only)

P-touch Editor Lite LAN is a basic version of a label-editing tool.

By copying P-touch Editor Lite LAN, installed from the enclosed CD-ROM, into a shared folder on the server, P-touch Editor Lite LAN on the server can be accessed by other network users to create labels, and print from PT-9800PCN connected to the network without installing any PT-9800PCN driver on the computer of each user.

### Note

- In order for P-touch Editor Lite LAN to be used, the IP address of this printer must be correctly specified.

The IP address can be specified with a utility such as BRAdmin Light, which can be installed from [Utility Installation] on the CD-ROM.

For details on using this utility, refer to “Setting the IP address and subnet mask” in the “Network User’s Guide” (PDF).

- On a network where the IP address is automatically assigned, for example, with DHCP, the IP address is automatically assigned when the printer is connected to the network, therefore the printer can be used immediately. However, since the IP address may change dynamically, we recommend specifying a static IP address when P-touch Editor Lite LAN is being used. For details, contact your network administrator.
- Specify the settings after consulting with your network administrator.

### ■ How to install P-touch Editor Lite LAN

- 1 Start the computer and put the CD-ROM into the CD-ROM drive.

### Note

- If it does not start up automatically, open the files on the CD-ROM and double-click on “Setup.exe”.

- 2 Click [Custom Installation].
- 3 Click [P-touch Editor Lite LAN].
- 4 Follow the on-screen instructions.

### ■ How to share P-touch Editor Lite LAN

- Copy the folder containing P-touch Editor Lite LAN from the shared folder on the network to your computer.
- Start up P-touch Editor Lite LAN from the shared folder on the network.

### Note

- A label created using P-touch Editor Lite LAN can only be printed from the PT-9800PCN connected to the network.

### ■ How to use P-touch Editor Lite LAN

- 1 Start P-touch Editor Lite LAN.



- 2 Enter the label text in P-touch Editor Lite LAN.

For example, click on the layout area and then type “Brother”.



- 3 Click on the “Print” button.



- 4 The label is printed.



## Note

- P-touch Editor Lite LAN is ideal for creating simple labels. To create labels with more complex designs, use P-touch Editor 5.0.
- When using P-touch Editor Lite LAN for the first time, the “Add shortcut” dialog box appears. Select the desired location from “Start menu”, “Desktop” or “Quick Launch bar”, then put a check mark in the box, and click [OK]. You can access P-touch Editor Lite LAN from the shortcut next time.
- Since P-touch Editor Lite LAN uses the network printing method and not the driver settings, high speed printing and high resolution printing using HG tape are not available.
- Print jobs from the full version of P-touch Editor sent from another computer may interrupt your printing. P-touch Editor Lite LAN will resume printing once the print job from the full version has been completed.
- For more detailed information, see the “Software User’s Guide” (PDF).

## Printing the printer settings

The printer settings page shows a report listing the printer settings and the network settings (PT-9800PCN only). You can print the printer settings page using the Feed/Cut button of the printer.

### Note

- In addition to other details, the node name and Ethernet address are printed in the printer settings list.
- The default Node name of the network card in the printer is “BRNXXXXXXXXXXXXXXXX” where “XXXXXXXXXXXXXXXX” is the Ethernet address.

- 1 Make sure that the TZ or HG tape cassette is installed and the tape compartment cover is closed.**  
To print the printer settings page, we recommend to use the tape wider than 24 mm.
- 2 Turn on the printer.**
- 3 Press and hold the Feed/Cut button to print out the settings.**

# Serial interface settings (Windows® only)

Use the following steps to change or confirm the port and the baud rate settings on the computer and the printer. Use the same settings for the printer and computer. The following procedure is shown based on Windows Vista®.

## Setting the computer baud rate

- 1 On the taskbar, click the “Start” button, and then click “Control Panel”.
- 2 Select “Printers and Other Hardware” (XP) / “Hardware and Sound” (Windows Vista®/Windows® 7) and then click “Printers and Faxes” (XP) / “Printer” (Windows Vista®/Windows® 7).
- 3 Right-click the “Brother PT-XXXX” icon, and then select “Properties”.
- 4 Click the “Ports” tab and then select the port you use from the list. To save the settings, click [Apply].
- 5 Click the “Device Settings” tab, and then click [Properties...] that appears next to Utilities.

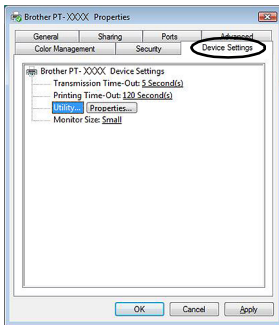

- 6 Select the desired baud rate.

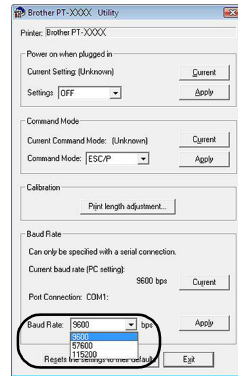

- 7 Click [Apply].  
The baud rate will be changed.
- 8 Click [Exit].
- 9 Click [OK].  
Setup is complete and the setting window will close.

## Setting the printer baud rate

For details on the setting the printer baud rate, download “P-touch Template manual” (English only) from the following web site.  
<http://solutions.brother.com/>  
Choose your region (eg. Asia/Oceania), your country, your model and Downloads for your model.

# Maintenance

Your printer should be cleaned on a regular basis to maintain its performance.

## Note

- Always disconnect the AC adapter prior to cleaning the printer.

## ■ Cleaning the exterior of the printer

Wipe any dust and marks from the main unit using a soft, dry cloth.  
Use a slightly dampened cloth with water on difficult to remove marks.

## Note

- Do not use paint thinner, benzene, alcohol or any other organic solvent. These may deform the case or damage the appearance of your printer.

## ■ Cleaning the print head and head roller

Streaks or poor quality characters on printed labels generally indicates that the print head and head roller are dirty. Clean the print head using a dry cotton swab, self-cleaning function or optional print head cleaning cassette (TZ-CL6). Refer to the instructions provided with the print head cleaning cassette for directions on how to use it.

### **⚠ WARNING**

Do not touch the print head directly with your bare hands. The print head may be hot.

### □ Self-cleaning function

Remove the tape cassette, and then press the Feed/Cut button.

### □ Cleaning the print head manually

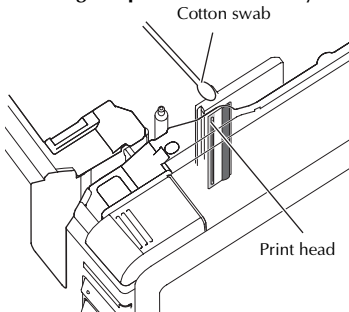

### □ Cleaning the head roller manually

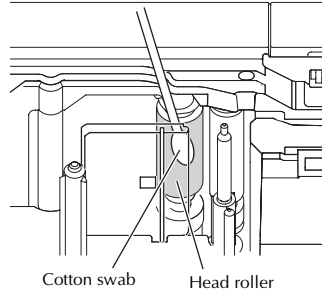

## ■ Cleaning the tape cutter

About once every year, wipe the cutter blades using a cotton swab moistened with isopropyl alcohol (rubbing alcohol). Tape adhesive can build up on the cutter blade after repeated use, taking the edge of the blade which may result in the tape jamming in the cutter.

### **⚠ CAUTION**

Do not touch the cutter blade with your finger.

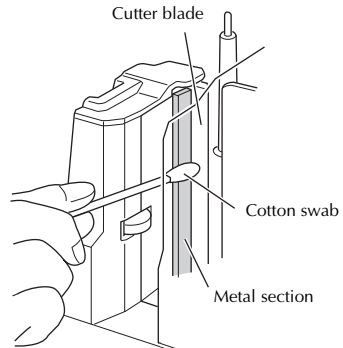

# Troubleshooting

For printer troubleshooting, refer to the following list of possible problems.

## Q & A

Problem	Solution
<b>The printer does not print. A printing error is received.</b>	Check that the interface cable is connected correctly, the tape cassette is installed correctly, and the tape compartment cover is closed.
<b>While printing, striped tape appears.</b>	The tape cassette is empty. Refer to "Installing the tape cassette" (→ P.15) and install a new tape cassette.
<b>There is about 1" of blank space at the leading edge of each printed label.</b>	Most TZ labels have a clear laminate top layer. This durable laminate helps the label withstand abrasion, fading and wet conditions providing a crisp, readable image. The process of adding this laminate layer results in the leading edge of blank space. Adjusting the label's margin or using the chain printing feature may reduce the amount of blank space.
<b>The label is not cut automatically.</b>	<ul style="list-style-type: none"><li>• Check the Auto Cut, Chain Printing and Special Tape settings.</li><li>• When using Fabric tapes or Non-laminated tapes, the label is not cut automatically. After printing, remove the tape cassette from the machine and use scissors to cut the tape. Be sure to read the instructions provided with tapes and observe all precautions noted in the instructions.</li></ul>
<b>The power button does not light up or flash.</b>	<ul style="list-style-type: none"><li>• Check that the main power switch on the back of printer is on.</li><li>• Check that the power supply and adapter cord is connected correctly. If the power button still does not light up or flash, contact the retail outlet where the printer was purchased or your local authorised service center.</li></ul>
<b>The printed label contains a blank horizontal line.</b>	There may be some dust on the print head. Refer to "Maintenance" (→ P.43) and clean the print head and head roller.
<b>After the labels are cut, they are not ejected from the printer correctly.</b>	The cutter blade may be dirty. Refer to "Maintenance" (→ P.43) and clean the cutter.
<b>A data transmission error appears on the computer.</b>	<ul style="list-style-type: none"><li>• The wrong port may be selected. For Windows®, select the correct port from the "Print to the following port" list in the printer Properties dialog box. For a USB connection, select "USB00n".</li><li>• Is someone printing via network? If you try to print while other users are printing large amounts of data, the printer is unable to accept your print job until the ongoing printing is finished. In such situations, restart the print job after the other jobs are completed.</li><li>• The baud rates for the computer and the printer may not be the same. Refer to "Setting the computer baud rate" (→ P.42) and change the baud rate.</li></ul>

Problem	Solution
<p>The baud rate cannot be set using the Change Baud Rate Wizard or the Brother printer utilities.</p>	<ul style="list-style-type: none"> <li>• Error 99: The computer cannot detect the printer. <ul style="list-style-type: none"> <li>- Make sure that the printer is turned on.</li> <li>- Make sure that the interface cable is connected correctly.</li> <li>- Make sure that the COM port where the printer is connected is the same COM port selected in the Change Baud Rate Wizard. (Many computers have more than one COM port and COM2 may have been mistakenly selected in the Change Baud Rate Wizard.)</li> </ul> </li> <li>• Error 1 or Error 5: The serial port of the computer cannot be used. <ul style="list-style-type: none"> <li>When another serial connection device is using the same COM port, labels cannot be printed. Change the COM port for the serial connection device or connect the printer to a COM port that is not being used.</li> </ul> </li> </ul>
<p>I want to reset the printer/delete the data transferred from computer.</p>	<p>To reset the printer, press and hold the power button to turn off the printer. Then, hold down the power button for two seconds. Continue holding down the power button, and press the Feed/Cut button six times. The printer will then reset. All the transferred data from the computer will be deleted and all printer settings will be reset to the factory settings.</p>
<p>I want to cancel the current printing job.</p>	<p>Make sure that the printer is on, and then briefly press the power button on the front of the printer.</p>
<p>Data cannot be sent from a device plugged into the USB Direct Interface on the front of the printer, or a connected device cannot be used (PT-9800PCN only).</p>	<ul style="list-style-type: none"> <li>• The connected device is incompatible with the PT-9800PCN. <ul style="list-style-type: none"> <li>If the LED display on USB Direct Interface is flashing in red, either the device is incompatible with the printer or the device consumes too much power. In either case, the device cannot be used with the PT-9800PCN.</li> </ul> </li> <li>• The buffer of the PT-9800PCN is full. <ul style="list-style-type: none"> <li>If the LED flashes in red while connected devices are being used, the buffer of the PT-9800PCN may have become full. Stop the data transmission, wait until the data buffered in the PT-9800PCN has been processed, and then unplug the device and plug it in again.</li> </ul> </li> </ul>
<ul style="list-style-type: none"> <li>• An error occurred during installation.</li> <li>• Installation cannot be performed with the CD-ROM.</li> </ul>	<p>Visit <a href="http://solutions.brother.com/">http://solutions.brother.com/</a></p>
<ul style="list-style-type: none"> <li>• I would like more information about the Add-Ins.</li> <li>• I do not understand how to connect to a database.</li> </ul>	<p>See the "Software User's Guide" (PDF).</p>

Problem	Solution
<p><b>I do not understand how to install the second printer that I have purchased.</b></p>	<ul style="list-style-type: none"> <li>• With a USB connection When the printer is connected to the computer using a USB cable, the driver for the second printer is automatically installed through Plug and Play.</li> <li>• With a Peer-to-Peer connection (PT-9800PCN only) <ul style="list-style-type: none"> <li>- If one PT-9800PCN is already installed: After the second printer is connected to the LAN, the installer starts up and the printer driver is installed. Both printers are listed in the dialog box where the printer can be selected. Identify the second printer by its IP address, and then select it. The selected printer driver is registered with the computer.</li> <li>- If multiple printers are to be installed at the same time: When the printers are connected to the LAN, the installer starts up and the printer drivers are installed. If multiple printers are selected in the list appearing in the dialog box where printers are selected, the selected printer drivers are registered with the computer.</li> </ul> </li> </ul>
<p><b>I do not understand how to share a printer on a network (PT-9800PCN only).</b></p>	<p>See the "Network User's Guide" (PDF).</p>

# Product specifications

## ■ Printer specifications

Item	Specification	
<b>Display</b>	Power lamp (green), STATUS lamp (red), USB Direct Interface lamp (green/red) (PT-9800PCN only)	
<b>Printing</b>	Printing method	Heat transfer laminated printing/thermal printing
	Print head	360 dpi/384 dot
	Print resolution	For TZ tape cassettes: 360 × 360 dpi For HG tape cassettes: 360 × 180 dpi, 360 × 360 dpi or 360 × 720 dpi
	Printing speed	For TZ tape cassettes: Up to 20 mm/sec For HG tape cassettes: Up to 80 mm/sec
	Maximum printing width	27.1 mm
<b>Buttons</b>	Power button, Feed/Cut button	
<b>Interface</b>	Serial (RS-232C), USB2.0 full speed LAN (10/100BASE-TX), USB Direct Interface (PT-9800PCN only)	
<b>Power source</b>	AC 220 to 240 V 50 Hz (AC adapter)	
<b>Power consumption</b>	Approx. 30 W (during printing)	
<b>Measurements</b>	116 × 193 × 140 mm (W × D × H)	
<b>Weight</b>	Approx. 1.58 kg	
<b>Cutter</b>	Auto full cutter/auto “crack and peel” cutter	

\* Auto “crack and peel” cutter is available only when using laminated tape.

\* When using Fabric tapes or Non-laminated tapes, the label is not cut automatically.

## ■ Operating environment

Item	Specification	
<b>OS</b>	<b>Windows®</b>	Windows® XP/Windows Vista®/Windows® 7, Windows Server® 2003/Windows Server® 2008/2008 R2 (for PT-9800PCN only) (Pre-installed device)
	<b>Macintosh®</b>	Mac OS® X 10.3.9 - 10.6
<b>Standard Interface</b>	<b>Windows®</b>	RS-232C, USB port (USB Spec. 1.1 or 2.0 protocol), (only for PT-9800PCN) 10/100BASE-TX Wired Ethernet
	<b>Macintosh®</b>	USB port (USB Spec. 1.1 or 2.0 protocol), (only for PT-9800PCN) 10/100BASE-TX Wired Ethernet
<b>Hard Disk</b>	<b>Windows®</b>	Disk space more than 70 MB
	<b>Macintosh®</b>	Disk space more than 100 MB
<b>Memory</b>	<b>Windows®</b>	Windows® XP: More than 128 MB Windows Server® 2003: More than 256 MB Windows Vista®/Windows Server® 2008/2008 R2: More than 512 MB Windows® 7: More than 1 GB (32-bit) or 2GB (64-bit)
	<b>Macintosh®</b>	Mac OS® X 10.3.9: More than 128 MB Mac OS® X 10.4.x: More than 256 MB Mac OS® X 10.5.x: More than 512 MB Mac OS® X 10.6: More than 1 GB
<b>Monitor</b>	<b>Windows®</b>	SVGA, high colour or higher graphics card
	<b>Macintosh®</b>	More than 256 colours
<b>Others</b>	CD-ROM drive	

## General procedure for the BTP (Bar code Template Print) function

The general procedure for using the BTP (Bar code Template Print) function is described below. For details on specifying the various settings, refer to “BTP (Bar code Template Print) function” (→ P.35).

**1** Use P-touch Editor 5.0 to create a template, and then transfer it to the printer.

**2** Connect the bar code reader to the printer.

**3** Scan the “P-touch template command” bar code.

This allows the settings to be specified or clears the previous settings.

**4** Scan the “Basic settings” bar codes.

Specify the cut method and the number of copies to be printed.

**5** Specify the appropriate settings (A, B or C).

**A.Preset template printing**

1.Scan the “Preset template number” bar code.

**B.Bar code printing**

1.Scan the “Select template” bar code, then the bar codes under “For entering numbers”.

2.Scan the bar code whose data is to be used or copied.

3.Scan the “Begin printing” bar code.

**C.Database-assisted label printing**

1.Scan the “Select template” bar code, then the bar codes under “For entering numbers”.

2.Scan the key bar code to replace the database data.

3.Scan the “Delimiter” bar code.

4.Scan the “Begin printing” bar code.

**6** The specified label is printed.

## List of bar codes for specifying settings

These are the bar codes for specifying settings used with the “BTP (Bar code Template Print) function” (→ P.35).

### Note

- When using the bar codes in this list, set “Trigger for P-touch Template Printing” and “Command Prefix Character” to default in P-touch Template Settings.

### ■ P-touch template command (Initialize + begin specifying settings)



Escia3^II

### ■ Basic settings

#### • Auto cut on\*<sup>1</sup>



^CF01

#### • Auto cut off



^CF00

#### • Half cut on\*<sup>1</sup>



^CH1

#### • Half cut off



^CH0

#### • Chain printing on



^CP1

#### • Chain printing off\*<sup>1</sup>



^CP0

#### • Mirror printing on



^MP1

#### • Mirror printing off\*<sup>1</sup>



^MPO

#### • Number of copies\*<sup>2</sup>



^CN

■ For entering numbers\*2

• 1



• 3



• 5



• 7



• 9



• 00



• 2



• 4



• 6



• 8



• 0



■ Preset template number

• Preset template 1



• Preset template 3



• Preset template 2



• Preset template 4



• Preset template 5



• Preset template 6



• Preset template 7



• Preset template 8



• Preset template 9



• Preset template 10



■ Select template



■ Delimiter



■ Begin printing



\*1 This is the default setting.

\*2 These are used when specifying the number of copies printed and when selecting a template number.

Scan bar codes to specify a three-digit number, such as [00][7] or [0][1][5]. The setting is automatically applied when three digits have been specified.

To change settings, scan the "Number of copies" bar code again when changing the number of copies or scan the "Select template" bar code again when changing the template number, and then scan the bar codes for the new three-digit number.

# Index

## A

- AC adapter ..... 7, 12
- AC adapter socket ..... 8

## B

- Bar code printing ..... 37
- Bar code Template Print ..... 35
- Bar codes for specifying settings ..... 49
- Baud rate ..... 42
- BRAdmin Light ..... 23
- BTP ..... 35

## C

- CD-ROM ..... 7
- Cleaning the exterior of the printer ..... 43
- Cleaning the print head and head roller ..... 43
- Cleaning the tape cutter ..... 43
- Connecting to a computer ..... 13
- Connecting to the power source ..... 12
- Cover release button ..... 8, 15

## D

- Database-assisted label printing ..... 38
- Default Serial settings ..... 35
- Deleting data transferred to the printer ..... 45
- Distributed printing ..... 33

## F

- Factory settings ..... 45
- Feed/Cut button ..... 8

## G

- General precautions ..... 5

## H

- HG Tapes ..... 15
- High resolution printing ..... 32
- High speed printing ..... 32

## I

- Installing the BRAdmin Light ..... 23, 28
- Installing the software ..... 16, 20
- Installing the tape cassette ..... 15
- Interface cables ..... 14

## L

- Label outlet ..... 8
- LAN port ..... 8
- LED lamp ..... 9

## M

- Main power switch ..... 8, 12
- Maintenance ..... 43

## N

- Network cable ..... 14

## O

- Operating environment ..... 47

## P

- Power button ..... 8, 12
- Power supply cord ..... 7, 12
- Preset template printing ..... 36
- Printer Settings print out ..... 41
- Printing the printer settings ..... 41
- Printing without computer ..... 35
- P-touch Editor Lite LAN ..... 40

## Q

- Q & A ..... 44

## R

- Reset to factory settings ..... 45

## S

- Safety precautions ..... 3
- Serial cable ..... 14
- Serial interface settings ..... 42
- Serial port ..... 8
- Specifications ..... 47
- STATUS lamp ..... 8

## T

- Tape cassette ..... 7
- Tape compartment cover ..... 8
- Troubleshooting ..... 44
- TZ Tapes ..... 15

## ***U***

Uninstalling the software.....	30
USB cable .....	7, 14
USB Direct Interface .....	8
USB port .....	8
User's Guide .....	7

**brother**®

Printed in China  
LW5584001④

