

brother®

TZ
TAPE

HG
TAPE

P-touch

9700PC/9800PCN

User's Guide

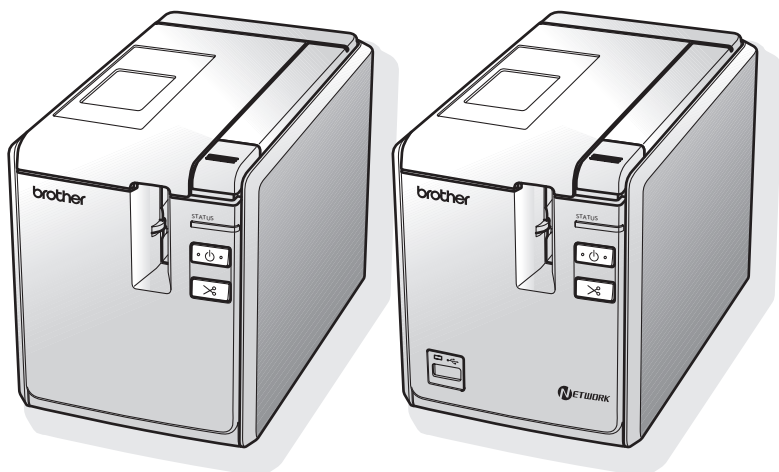

If you encounter any problems with your product, visit our Web site:
<http://solutions.brother.com/>

Introduction

Thank you for purchasing the PT-9700PC/PT-9800PCN.

The PT-9700PC/PT-9800PCN (hereafter, referred to as "printer") is a label printer that enables you to easily print custom labels after it is connected to a computer. Also, with a bar code reader connected to the printer, labels and bar codes can easily be printed by scanning bar codes. This manual contains various precautions and basic procedures for using this printer. Read this manual carefully before starting and keep the manual in a handy place for future reference.

Declaration of conformity (Europe Only)

We, BROTHER INDUSTRIES, LTD

15-1, Naeshiro-cho, Mizuho-ku, Nagoya, 467-8561, Japan declare that this product is in compliance with the essential requirements and other relevant provisions of Directives 2004/108/EC and 2005/32/EC.

The Adapter AD9100ES is in compliance with the essential requirements and other relevant provisions of Directive 2006/95/EC.

The Declaration of Conformity (DoC) is on our Web site.

Please go to <http://solutions.brother.com>

→ choose region (eg. Europe)

→ choose country

→ choose your model

→ choose "Manuals"

→ choose Declaration of Conformity (* Select Language when required.)



International ENERGY STAR® Compliance Statement

The purpose of the International ENERGY STAR® Program is to promote the development and popularization of energy-efficient office equipment.

As an ENERGY STAR® Partner, Brother Industries, Ltd. has determined that this product meets the ENERGY STAR® guidelines for energy efficiency.

Compilation and Publication Notice

Under the supervision of Brother Industries, Ltd., this manual has been compiled and published, covering the latest product's descriptions and specifications.

The contents of this manual and the specifications of this product are subject to change without notice.

If new versions of the PT-9700PC/9800PCN software become available, this manual may not reflect the updated features. Therefore, you may find that the software and the contents in this manual are different.

Brother reserves the right to make changes without notice in the specifications and materials contained herein and shall not be responsible for any damages (including consequential) caused by reliance on the materials presented, including but not limited to typographical and other errors relating to the publication. The screen images in this manual may differ depending on your OS or printer.

© 2010 Brother Industries, Ltd.

Trademarks and Copyrights

The Brother logo is a registered trademark of Brother Industries, Ltd.

Brother is a registered trademark of Brother Industries, Ltd.

© 2010 Brother Industries, Ltd. All rights reserved.

Microsoft, Windows Vista, Windows Server and Windows are registered trademarks of Microsoft Corporation in the United States and other countries.

Apple, Macintosh and Mac OS are trademarks of Apple Inc., registered in the United States and other countries.

QR Code is a registered trademark of DENSO WAVE INCORPORATED in JAPAN and other countries. QR Code Generating Program © 2008 DENSO WAVE INCORPORATED.

BarStar Pro Encode Library (DataMatrix, MaxiCode, PDF417, RSS) © 2007 AINIX Corporation. All rights reserved.



The names of other software or products used in this document are trademarks or registered trademarks of the respective companies that developed them.

Each company whose software title is mentioned in this manual has a Software Licence Agreement specific to its proprietary programs.









Any trade names and product names of companies appearing on Brother products, related documents and any other materials are all trademarks or registered trademarks of those respective companies.

Safety precautions

To prevent injury and damage, important notes are explained using various symbols. The symbols and their meanings are as follows:

 WARNING	Tells you what to do to avoid accidents and the risk of injury.
 CAUTION	Tells you about procedures you must follow to avoid minor personal injury or damage to the printer.











The symbols used in this manual are as follows:

	Action NOT allowed.		DO NOT disassemble the product.
	DO NOT splash the product with or immerse the product in water.		DO NOT touch a given portion of the product.
	Mandatory action.		Unplugging.
	Safety alert.		Alerts to the possibility of electrical shock.

WARNING

AC adapter



Follow these guidelines to avoid fire, damage, electric shock, failure or the risk of injury.

-  Use only the AC adapter (AD9100ES), adapter cord, power supply cord and USB cable designed exclusively for your printer. Failure to observe this may result in an accident or damage. Brother shall not assume any responsibility for any accident or damage resulting from not using the specified AC adapter (AD9100ES), adapter cord, power supply cord and USB cable.
-  Don't connect the enclosed AC adapter (AD9100ES), adapter cord, power supply cord and USB cable to other products.
-  Unplug the power supply cord immediately and stop using the printer during an electrical storm. There may be a remote risk of electric shock from lightning.
-  Do not touch the AC adapter or power plug with wet hands.
-  Do not use the AC adapter in places of high humidity such as bathrooms.
-  Do not use a damaged adapter cord or power supply cord.
-  Do not overload the power outlet.
-  Do not place heavy objects on, damage or modify adapter/power supply cord or plug. Do not forcibly bend or pull these cord.
-  Do not drop, hit or otherwise damage the AC adapter.
-  Make sure that the plug is fully inserted in the power outlet. Do not use an outlet that is loose.

WARNING





Printer

Follow these guidelines to avoid fire, damage, electric shock, and/or the risk of injury.

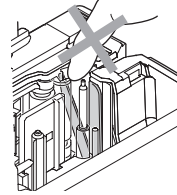
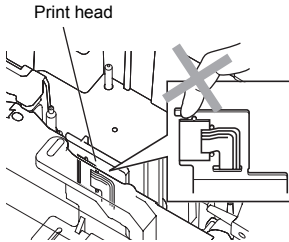
-  Do not allow the printer to get wet in any way.
-  Do not touch the blade of the cutter unit.

-  Do not touch any metal parts near the print head. The print head becomes very hot during use and remains very hot immediately after use. Do not touch it directly with your hands.





-  Do not use the printer with a foreign object in it. If water, metallic substance or any foreign object enters the printer, disconnect the AC adapter and contact the retail outlet where the printer was purchased or your local authorised service center.
-  Do not disassemble the printer. For inspection, adjustment, and repair of the printer, contact the retail outlet where the printer was purchased or your local authorised service center.
-  Plastic bags are used in the packaging of your printer. To avoid danger of suffocation, keep these bags away from babies and children.
-  Disconnect the AC adapter immediately and stop using when you notice abnormal odour, heat, discolouration, deformation or anything unusual while using or storing it.
-  To prevent damage, do not drop or hit the printer.

CAUTION

Tape cutter

Follow these guidelines to avoid minor personal injury and damage to the printer.



-  Do not open the tape compartment cover when operating the cutter unit.
-  Do not apply excessive pressure to the cutter unit.

AC adapter

-  If you do not intend using the printer for an extended period of time, please disconnect the AC adapter from the power outlet.
-  Always hold the plug when disconnecting the power supply cord from the power outlet.

Printer

Follow these guidelines to avoid minor personal injury and damage to the printer.

-  Place the printer on a flat, stable surface such as a desk.
-  Do not place any heavy objects on top of the printer.
-  Do not leave the printer within reach of children with the tape compartment cover open.

General Precautions



- The printer may malfunction if left near a television, radio, etc. Do not use the printer near any device that will cause electromagnetic interference.
- Do not use the printer in any way or for any purpose not described in this manual. Doing so may result in accidents or damage to the printer.
- Do not put any foreign objects into the label outlet, AC adapter socket, USB port, serial port or LAN port (PT-9800PCN only), etc.
- Do not touch the print head with your fingers. Use the optional print head cleaning cassette (TZ-CL6), the self-cleaning function of the printer or a soft wipe (e.g. a cotton swab) when cleaning the print head (→ P. 43).
- Do not clean the printer with alcohol or other organic solvents. Only use a soft, dry cloth.
- Do not place the printer in direct sunlight or rain, near heaters or other hot appliances, in any location exposed to extremely high or low temperatures (e.g. on the dashboard or in the back of your car), high humidity, or dusty locations. Standard operating temperature range: 10 to 30°C.
- Do not leave any rubber or vinyl on the printer for an extended period of time, otherwise the printer may be stained.
- Depending on the environmental conditions and the applied settings, some characters or symbols may be difficult to read.
- Use only Brother TZ tapes or Brother HG tapes with this printer. Do not use tapes that do not have the  or  mark.
- Do not pull or apply pressure to the tape in the cassette. Otherwise the tape cassette or printer may be damaged.
- Do not try to print labels using an empty tape cassette or without a tape cassette set in the printer. Doing so will damage the print head.
- Do not attempt to cut the tape while printing or feeding since this will damage the tape.
- Be careful not to scratch the CD-ROM. Do not place the CD-ROM in any location exposed to high or low temperatures. Do not place heavy objects on the CD-ROM or bend it.
- The software on the CD-ROM is intended for use with the printer and may be installed on more than one computer.
- We strongly recommend that you read this User's Guide carefully before using your printer, and then keep it nearby for future reference.
- Depending on the location, material, and environmental conditions, the label may unpeel or become irremovable, the colour of the label may change or be transferred to other objects. Before applying the label, check the environmental condition and the material.
- Do not expose the tape cassettes to direct sunlight, high temperatures, high humidity, or dust. Store tape cassettes in a cool, dark place. Use the tape cassettes soon after opening the tape cassette package.
- Markings made with oil-based or water-based ink may be visible through a label affixed over them. To hide the markings, use two labels layered on top of each other or use a dark-coloured label.
- Note that Brother Co., Ltd. does not assume responsibility for any damage, etc. arising from failure to follow the precautions listed.

Table of contents

Unpacking the printer	7
General description	8
LED lamps	9
Getting ready to use your printer	11
Connecting the printer	12
Connecting to the power source	12
Connecting to a computer	13
Using the interface cables	14
Installing the tape cassette	15
Authorised tape	15
Installing the tape cassette	15
Installing the software for PT-9700PC	16
When using Microsoft® Windows®	16
When using Mac OS®	18
Installing the software for PT-9800PCN	20
When using Microsoft® Windows®	20
When using Mac OS®	24
Uninstalling the software	30
When using Microsoft® Windows®	30
When using Mac OS®	31
Advanced function	32
Printing at a higher speed or at a higher resolution	32
Distributed printing	33
BTP (Bar code Template Print) function	35
Using P-touch Editor Lite LAN (PT-9800PCN and Windows® only)	40
Printing the printer settings	41
Serial interface settings (Windows® only)	42
Setting the computer baud rate	42
Setting the printer baud rate	42
Maintenance	43
Troubleshooting	44
Q & A	44
Product specifications	47
Appendix	48
General procedure for the BTP (Bar code Template Print) function	48
List of bar codes for specifying settings	49
Accessories	52
Index	57

Unpacking the printer

Open the box and confirm that the following items are included. If any item is missing or damaged, please contact your Brother dealer or Brother Customer Service.

■ PT-9700PC/PT-9800PCN

Printer (PT-9700PC)

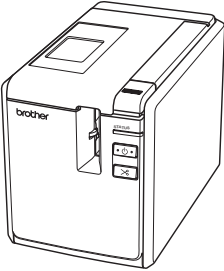

Printer (PT-9800PCN)

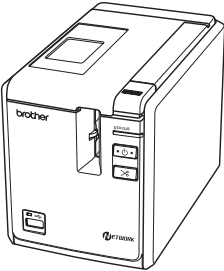

■ AC adapter (with adapter cord)

Connect to the power supply cord.

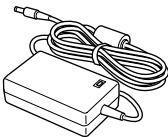

■ Power supply cord

Connect to the AC adapter and an electrical outlet (AC 220 to 240 V).

(The design of the AC power plug may differ by country.)

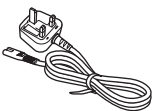

■ USB cable

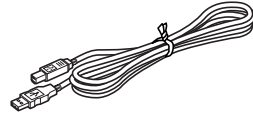

■ Tape cassette

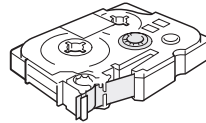

■ User's Guide

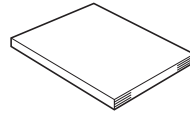

■ CD-ROM

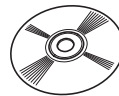

■ Tape catalogue

General description

■ PT-9700PC

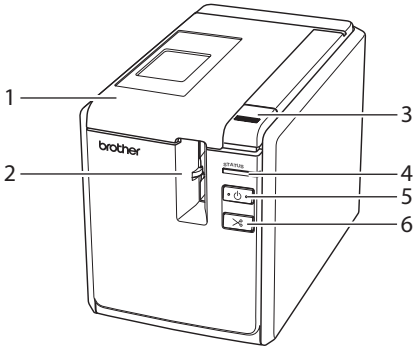

Front view

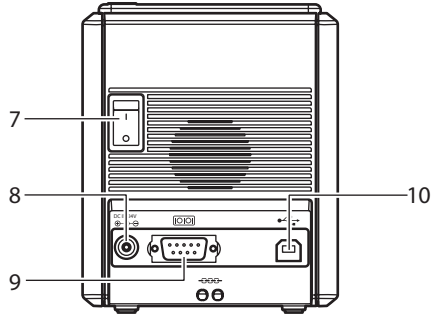

Rear view

■ PT-9800PCN

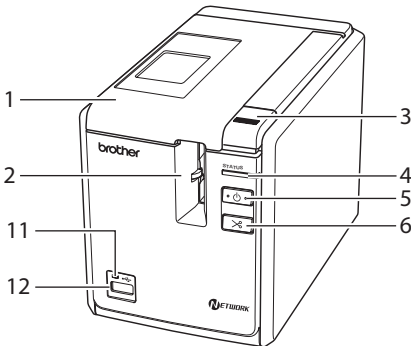

Front view

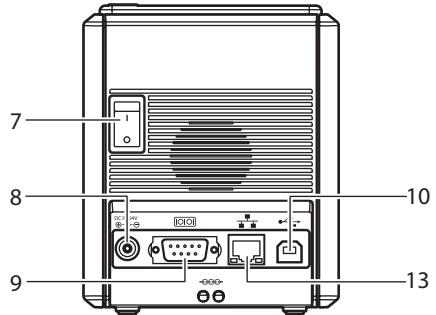

Rear view

1. Tape compartment cover
2. Label outlet
3. Cover release button
4. STATUS lamp
5. Power button (including lamp)
6. Feed/Cut button
7. Main power switch
8. AC adapter socket
9. Serial (RS-232C) port
10. USB port
11. LED lamp on USB Direct Interface (PT-9800PCN only)
12. USB Direct Interface for connecting a Bar code Reader (PT-9800PCN only)
13. LAN (10/100BASE-TX Wired Ethernet) port (PT-9800PCN only)

Note

- If the tape compartment cover is left open, dust will collect on the print head. Always close the cover.

LED lamps

The condition of the printer shown by LED lamps on printer or USB Direct Interface (PT-9800PCN only).

■ LED lamps on printer

Lamp condition		Condition	Remedy
Power lamp (green)	STATUS lamp (red)		
On	Off	Printer standby condition	—
Flashing	Off	Receiving data	—
Flashing	On	During the printer receiving data	
		1) No tape cassette.	1) Install the tape cassette and close the tape compartment cover.
		2) Tape compartment cover is open.	2) Close the cover.
On	On	3) Incompatible tape cassette.	3) Install the correct tape cassette and close the tape compartment cover.
		During the printer standby	
		1) No tape cassette.	1) Install the tape cassette and close the tape compartment cover.
On	Flashing	2) Tape compartment cover is open.	2) Close the cover.
		3) Incompatible tape cassette.	3) Install the correct tape cassette and close the tape compartment cover.
		During printing	
On	Flashing	1) No tape cassette.	1) Install the tape cassette and close the tape compartment cover.
		2) Tape compartment cover is open.	2) Close the cover.
		3) Incorrect tape cassette.	3) Change the software setting or install the correct tape cassette.
On	Flashing	4) Incompatible tape cassette.	4) Install the correct tape cassette and close the tape compartment cover.
		Empty tape cassette	Install a tape cassette containing tape and close the tape compartment cover.
		Transmission error	Press the power button on the front of the printer.

Lamp condition		Condition	Remedy
Power lamp (green)	STATUS lamp (red)		
On	Flashing fast	Cutter error	Confirm that the tape is not jammed in the printer. If necessary, turn the printer off and on with the power button. If the STATUS lamp continues to flash, contact your Brother dealer or Brother Customer Service.
		Roller holder error	
		Print head overheat error	
On	Flashing very fast	EEPROM error	Turn the printer off and on with the power button. If the STATUS lamp continues to flash, contact your Brother dealer or Brother Customer Service.
		Circuit board error	
Off	On	Booting	—

■ LED lamp on USB Direct Interface (PT-9800PCN only)

Lamp condition		Condition	Remedy
Colour	Condition		
—	Off	USB device not connected	—
Green	On	USB device connected	—
Red	Flashing	HUB connected	Disconnect the USB device.
	Flashing fast	Noncompliant USB device connected	Disconnect the USB device.
		"Buffer full" error with USB Direct Interface	Data sent from the bar code reader is saved on the printer. Do not use the bar code reader to consecutively scan bar codes and do not use the bar code reader with multiple interfaces at the same time.
	Flashing very fast	Overcurrent	Disconnect the USB device and turn the printer off and on with the power button.

Getting ready to use your printer

Before creating labels with the printer, the following preparations are necessary.

Note

- The connection procedures are different depending on the operating system running on the computer. They will also vary depending on whether a USB connection, serial connection or network connection (PT-9800 PCN only) is used. For details on connecting the printer to your specific computer, refer to “Connecting to a computer” (→ P. 13).

Connecting the printer

Connect the printer to the power source and your computer, and install a tape cassette. For details, refer to “Connecting the printer” (→ P. 12) and “Installing the tape cassette” (→ P. 15).

Installing the software

You will need to install the printer driver to use your printer with your computer. You will also need to install P-touch Editor label design software. For details on installing this software, refer to “Installing the software for PT-9700PC” (→ P. 16) or “Installing the software for PT-9800PCN” (→ P. 20).

Creating labels

After setting up your printer you can start creating labels. For details on how to design and create labels, refer to the “Software User’s Guide” (PDF). For detailed feature explanations, you may also reference the P-touch Editor Help menu found in the software.

Connecting the printer

Connect the printer to the power source and a computer.

Connecting to the power source

- 1 Connect the included power supply cord to the AC adapter.

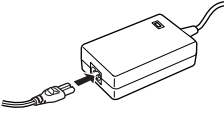

- 2 Insert the AC adapter connector into the AC adapter socket on the back of the printer.

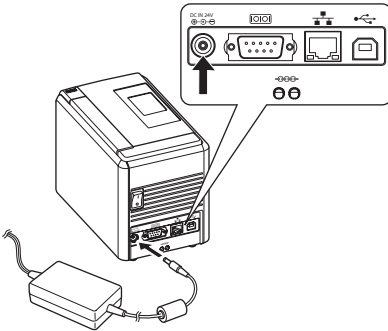

- 3 Plug the power supply cord into an electrical outlet (AC 220 to 240 V).

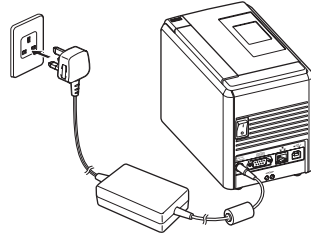

- 4 Turning on the printer

Turn on the main power switch on the back of the printer, and then press the power button on the front of the printer.

Turning off the printer

Hold down the power button on the front of the printer until the printer is turned off, and then turn off the main power switch on the back of the printer.

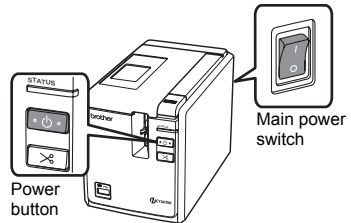

Note

- Always turn the power off first using the power button on the front of the printer before removing the AC adapter or turning off the main power switch.
- After using the printer, disconnect the power supply cord from the electrical outlet and the AC adapter from the printer and store them for future use.
- When removing the AC adapter always pull the plug. Do not pull the AC adapter or power supply cord. The wire in the cords may break.
- Do not use any AC adapter other than the one included with the printer. Failure to observe this may result in an accident.

Connecting to a computer

Connect the printer to a computer using the interface cables. The interface cables used to connect to a USB port, serial (RS-232C) port and LAN (10/100BASE-TX Wired Ethernet) port are different.

	Operation Systems	Basic Setup		Serial port (ESC/P and P-touch Template only)
		USB port	LAN port	
PT-9700PC	Windows® XP/Windows Vista®/ Windows® 7	Yes	No	Yes
	Mac OS® X 10.3.9-10.6			No
PT-9800PCN	Windows® XP/Windows Vista®/ Windows® 7/Windows Server® 2003/Windows Server® 2008/ 2008 R2	Yes	Yes	Yes
	Mac OS® X 10.3.9-10.6			No

Using the interface cables

Serial (RS-232C) cables and network (Ethernet) cables are not standard accessories. Use the appropriate cable for your type of interface.

Note

- For USB interface, the included USB interface cable should be used to ensure compliance with the limits for EMC.
- For serial and network interfaces, a shielded interface cable should be used to ensure compliance with the limits for EMC.
- Changes or modifications not expressly approved by Brother Industries, Ltd. may affect the performance and print quality, and damage may not be covered under the limited warranty.

■ USB cable

Use the enclosed interface cable.

■ Serial (RS-232C) cable (Windows® only)

The pin assignments for the serial cables (RS-232C cables) which can be used with this printer are shown in the table below. You can purchase the cables at an electronics store. Do not use a serial cable that is longer than 1.8 m.

Brother printer side

(D-Sub female, lock screw #4-40 inch screw)

Computer side

(D-Sub9P female)

Signal Name	Pin Number	Pin Assignments	Pin Number	Signal Name
DCD	1		1	DCD
RXD	2		2	RXD
TXD	3		3	TXD
DTR	4		4	DTR
GND	5		5	GND
DSR	6		6	DSR
RTS	7		7	RTS
CTS	8		8	CTS
RI	9		9	RI

Note

- The RS-232C serial connector part of this equipment is not Limited Power Source.
- For details on serial interface settings, refer to "Serial interface settings (Windows® only)" (→ P. 42).

■ Network cable (PT-9800PCN only)

Use a straight-through Category5 (or greater) twisted-pair cable for 10BASE-T or 100BASE-TX Fast Ethernet Network.

Note

- Connect this product to a LAN connection that is not subjected to overvoltages.

Installing the tape cassette

This section lists the types of tape that may be used with the printer and explains the procedures to install the tape cassettes.

Authorized tape

The types of tape that may be used with the printer are listed below. For details on the tapes, refer to "Accessories" (→ P. 52).

■ TZ Tapes

- Standard Laminated Tape
- Standard Non-Laminated Tape
- Strong Adhesive Tape - Laminated
- Flexible ID tape - Laminated
- Fabric Iron-On Tape - Non-Laminated
- Security Tape - Laminated
- Stencil Tape - Non-Laminated

■ HG Tapes

HG tapes enable three available combinations of higher printing speed and print resolutions. For details on high-speed printing, refer to "Printing at a higher speed or at a higher resolution" (→ P. 32).

Installing the tape cassette

This section explains the procedure to install the tape cassette.

1 Hold down the power button on the front of the printer until the Power lamp is off.

2 Press the cover release button and open the tape compartment cover.

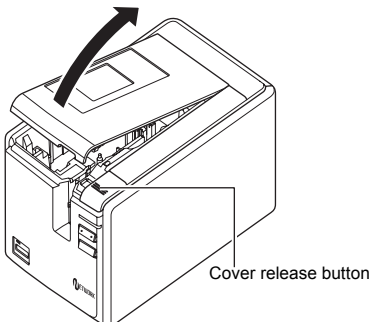

3 Install the tape cassette. Make sure that the end of the tape feeds under the tape guide.

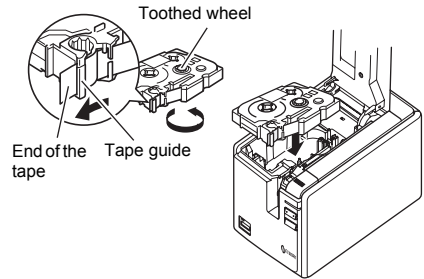

- If the ink ribbon is loose, use your finger to wind the toothed wheel in the direction of the arrow on the cassette.

4 Close the tape compartment cover and press the power button on the front of printer.

5 Press the Feed/Cut button to remove the tape slack.

Note

- You can only remove the tape cassette when the roller assembly of the printer has been released. It will be released automatically if you press the power button on the front of the printer or if no additional operation is performed within 10 minutes after printing a label.

Installing the software for PT-9700PC

The procedure for installing the software varies depending on the OS of the computer. Installation procedure is subject to change without notice.

For Microsoft® Windows® users, see “When using Microsoft® Windows®” (→ P. 16).

For Macintosh® users, see “When using Mac OS®” (→ P. 18).

Note

- If you will be using the models “PT-9700PC”, it is necessary to install the following versions of P-touch Editor or b-PAC SDK to avoid printing difficulties:
 - [P-touch Editor] version 5.0.101 and later (included on CD).
 - [b-PAC SDK] version 3.0.010 and later (download from Brother Solutions Center).
- For details of the software, see the “Software User’s Guide” (PDF).
- You can find the “Software User’s Guide” (PDF) by clicking “Start” - “All Programs (Programs)” - “Brother P-touch” - “Manuals” - “PT-9700PC” - “Software User’s Guide”.

When using Microsoft® Windows®

This section explains how to install P-touch Editor 5.0, the printer driver and Software User’s Guide (PDF).

Note

- Do not connect the printer to the computer until directed to do so.
- You must be logged on as a user with administrator privileges to install this software.
- Turn off the printer with the power button and then with the main power switch.

The following is the example for Windows Vista®.

1 Start the computer and put the CD-ROM into the CD-ROM drive.

Note

- If it does not start up automatically, open the files on the CD-ROM and double-click on “Setup.exe”.

2 Click [Standard Installation].

Installation items:

- Standard Installation**
P-touch Editor 5.0, printer driver, and Software User’s Guide (PDF).
- Custom Installation**
P-touch Editor 5.0, printer driver, and Software User’s Guide (PDF) can all be installed separately.

Display User’s Guide

Software User’s Guide (PDF)
(PDF reader software required).

Adobe Reader Download

Link to the download page for Adobe® Reader® will be displayed.



3 Read the licence agreement and click [Yes] if you agree with the terms and conditions.

Follow the on-screen instructions.

4 Put a check mark in the box next to the Add-In programs you want to install, and click [Next].

With the Add-In feature you can use texts from those applications easily in our label layouts.

Note

- Make sure that all Microsoft® Office applications are closed.

5 Select the desired model, and then click [OK].

Follow the on-screen instructions of the driver installation.

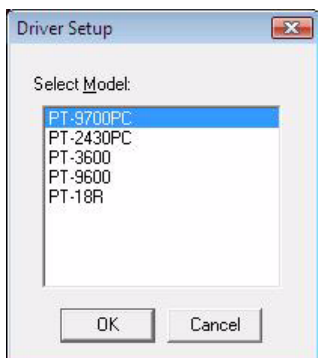

6 When instructed, connect your printer to the computer by using the USB cable, and then turn on the printer.

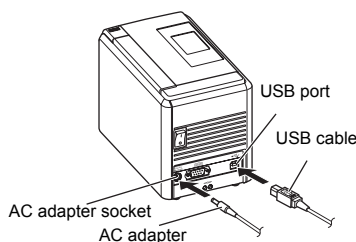

7 Once the printer is detected, the driver will automatically be installed.

8 When instructed to register your printer online, select a registration method and click [Next].

If you have selected to register the product online, your default internet browser will be launched in a new window. Follow the instructions to register your printer.

9 When instructed to download the optional tools, select your choice and click [Next].

- If you choose “Yes, display the page”, you will go to the Brother Solutions Center web site before finishing the installation (recommended). Choose your region (eg. Europe), your country, your model and Downloads for your model.

- If you choose “No, do not display the page”, you will continue the installation.

Note

- To download the optional tools later, you can find them on this Web site: <http://solutions.brother.com/>
Choose your region (eg. Europe), your country, your model and Downloads for your model.

10 Click [Finish].
The software installation is now complete. Restart your computer if you are instructed to do so.

11 Start the software.
Click “Start” - “All Programs (Programs)” - “Brother P-touch” - “P-touch Editor 5.0” to start P-touch Editor 5.0.

When using Mac OS®

This section explains how to install P-touch Editor 5.0 and the printer driver.

Note

- Do not connect the printer to your Macintosh® before P-touch Editor 5.0 installation has been completed.
- You must be logged on as a user with administrator privileges to install this software.
- Turn off the printer with the power button and then with the main power switch.

Below is the example for Mac OS® X 10.5.7.

- 1 Start up the Macintosh®, and insert the CD-ROM into the CD-ROM drive.** Double-click the “PT_Series” (CD-ROM) icon.



- 2 Double-click “Brother PT-9700PC Driver.pkg” in the “Mac OS X” folder.** The Driver Installer starts up. Follow the on-screen instructions.



- 3 After the installation is completed and the screen shown below is displayed, click [Close].**

The installation of the printer driver is completed.

Next, install the P-touch Editor 5.0.

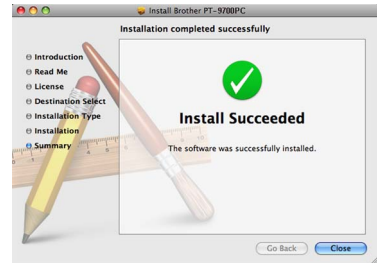

- 4 Double-click “P-touch Editor 5.0 Installer.mpkg”.**

The P-touch Editor 5.0 Installer starts up. Follow the on-screen instructions.



- 5 When the installation is completed and the message “Click Restart to finish installing the software.” is displayed, click [Restart].**

The Macintosh® is restarted.

The installation of software is completed.

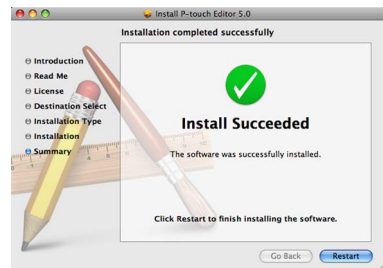

- 6** After restarting the Macintosh®, connect your printer to the Macintosh® by using the USB cable, and then turn on the printer.

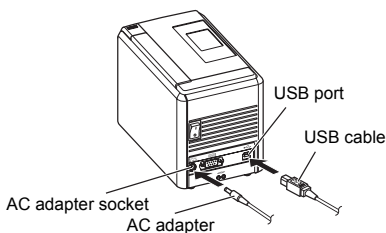

Note

- If you are connecting the printer to the Macintosh® via a USB hub, it may not be detected correctly. If so, connect the printer directly to the USB port on the Macintosh®.

- 7** For Mac OS® X 10.3.9 - 10.4.x Double-click the drive where Mac OS® X is installed, and click “Applications” - “Utilities” - “Printer Setup Utility”.

For Mac OS® X 10.5.x - 10.6

Click Apple menu - “System Preferences”, and click “Print & Fax”.

- 8** For Mac OS® X 10.3.9 - 10.4.x Click [Add] and choose USB at the top of the screen. Choose “PT-9700PC” from the list and click [Add] again to add the printer to the “Printer List”.

For Mac OS® X 10.5.x - 10.6

Choose “Brother PT-9700PC” from the list and click [Add] /  to add the printer to the “Printer List” / “Print & Fax”.

- 9** When the screen returns to the “Printer List” / “Print & Fax” screen, check that the “PT-9700PC/Brother PT-9700PC” is added, and close the “Printer List” / “Print & Fax” screen. Now you can use the printer.

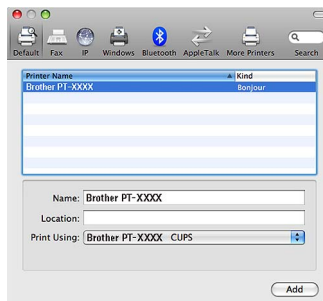

Installing the software for PT-9800PCN

The procedure for installing the software varies depending on the OS of the computer. Installation procedure is subject to change without notice.

For Microsoft® Windows® users, see “When using Microsoft® Windows®” (→ P. 20).

For Macintosh® users, see “When using Mac OS®” (→ P. 24).

Note

- If you will be using the models “PT-9800PCN”, it is necessary to install the following versions of P-touch Editor or b-PAC SDK to avoid printing difficulties:
 - [P-touch Editor] version 5.0.101 and later (included on CD).
 - [b-PAC SDK] version 3.0.010 and later (download from Brother Solutions Center).
- For details of the software, see the “Software User’s Guide” (PDF).
- For details of the Network, see the “Network User’s Guide” (PDF).
- You can find the Software User’s Guide or Network User’s Guide (PDF) by clicking “Start” - “All Programs (Programs)” - “Brother P-touch” - “Manuals” - “PT-9800PCN” - “Software User’s Guide” or “Network User’s Guide”.

When using Microsoft® Windows®

This section explains how to install P-touch Editor 5.0, the printer driver, Software User’s Guide (PDF) and Network User’s Guide (PDF).

Note

- When using USB interface cable, do not connect the printer to the computer until directed to do so.
- You must be logged on as a user with administrator privileges to install this software.
- Turn off the printer with the power button and then with the main power switch.

The following is the example for Windows Vista®.

1 Start the computer and put the CD-ROM into the CD-ROM drive.

Note

- If it does not start up automatically, open the files on the CD-ROM and double-click on “Setup.exe”.

2 Click [Standard Installation].

Installation items:

- Standard Installation**
P-touch Editor 5.0, printer driver, Software User’s Guide (PDF), and Network User’s Guide (PDF).

Custom Installation

P-touch Editor 5.0, printer driver, Software User’s Guide (PDF), Network User’s Guide (PDF), and P-touch Editor Lite LAN can all be installed separately.

Utility Installation

BRAdmin Light
How to install BRAdmin Light, see page 23.

User’s Guide

Software User’s Guide (PDF), Network User’s Guide (PDF), and link to the download page for Adobe® Reader®.



3 Read the licence agreement and click [Yes] if you agree with the terms and conditions.

Follow the on-screen instructions.

4 Put a check mark in the box next to the **Add-In programs** you want to install, and click **[Next]**.

With the Add-In feature you can use texts from those applications easily in our label layouts.

Note

- Make sure that all Microsoft® Office applications are closed.

5 Then, choose your connection method and click **[Next]**.

Connection method:

- Local Printer with USB cable**
See “For USB interface cable users” (→ P. 21).
- Brother Peer-to-Peer Network Printer**
Check the LAN cable is connected to the printer.
See “For network interface cable users” (→ P. 22).
- Network Shared Printer**
Check the LAN cable is connected to the printer.
See “For shared network printer users” (→ P. 22).

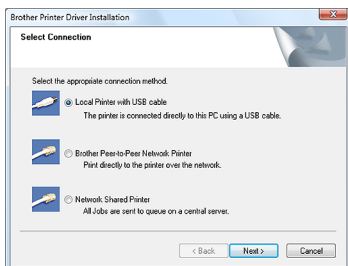

Note

- When using USB interface cable, do not connect the printer to the computer until directed to do so.

■ For USB interface cable users

6 Follow the on-screen instructions. When this screen appears, confirm the printer is powered on. Connect the USB interface cable to your computer, and then connect it to the printer.

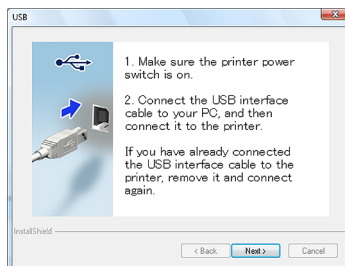

7 When instructed to register your printer online, select a registration method and click **[Next]**.

If you have selected to register the product online, your default internet browser will be launched in a new window. Follow the instructions to register your printer.

8 When instructed to download the optional tools, select your choice and click **[Next]**.

- If you choose “Yes, display the page”, you will go to the Brother Solutions Center web site before finishing the installation (recommended). Choose your region (eg. Europe), your country, your model and Downloads for your model.
- If you choose “No, do not display the page”, you will continue the installation.

Note

- To download the optional tools later, you can find them on this Web site: <http://solutions.brother.com/> Choose your region (eg. Europe), your country, your model and Downloads for your model.

9 Click **[Finish]**.

The software installation is now completed. Restart your computer if you are instructed to do so.

10 Start the software.

Click “Start” - “All Programs (Programs)” - “Brother P-touch” - “P-touch Editor 5.0” to start P-touch Editor 5.0.

■ For network interface cable users

- 6** Choose “Search the network for devices and choose from a list of discovered devices (Recommended).” Or enter your printer’s IP address or its node name. Click [Next].

You can find your printer’s IP address and the node name by printing out the printer settings page. For details, refer to “Printing the printer settings” (→ P. 41).

- 7** Choose your printer.
Follow the on-screen instructions.

- 8** When instructed to register your printer online, select a registration method and click [Next].
If you have selected to register the product online, your default internet browser will be launched in a new window. Follow the instructions to register your printer.

- 9** When instructed to download the optional tools, select your choice and click [Next].
- If you choose “Yes, display the page”, you will go to the Brother Solutions Center web site before finishing the installation (recommended). Choose your region (eg. Europe), your country, your model and Downloads for your model.
 - If you choose “No, do not display the page”, you will continue the installation.

Note

- To download the optional tools later, you can find them on this Web site: <http://solutions.brother.com/> Choose your region (eg. Europe), your country, your model and Downloads for your model.

- 10** Click [Finish].
The software installation is now completed. Restart your computer if you are instructed to do so.

- 11** Start the software.
Click “Start” - “All Programs (Programs)” - “Brother P-touch” - “P-touch Editor 5.0” to start P-touch Editor 5.0.

■ For shared network printer users

- 6** Choose your printer’s queue, and then click [OK].
Follow the on-screen instructions.

Note

- Contact your administrator if you do not know the location or the name of the printer in the network.

- 7** When instructed to register your printer online, select a registration method and click [Next].
If you have selected to register the product online, your default internet browser will be launched in a new window. Follow the instructions to register your printer.

- 8** When instructed to download the optional tools, select your choice and click [Next].
- If you choose “Yes, display the page”, you will go to the Brother Solutions Center web site before finishing the installation (recommended). Choose your region (eg. Europe), your country, your model and Downloads for your model.
 - If you choose “No, do not display the page”, you will continue the installation.

Note

- To download the optional tools later, you can find them on this Web site: <http://solutions.brother.com/> Choose your region (eg. Europe), your country, your model and Downloads for your model.

- 9** Click [Finish].
The software installation is now completed. Restart your computer if you are instructed to do so.

- 10** Start the software.
Click “Start” - “All Programs (Programs)” - “Brother P-touch” - “P-touch Editor 5.0” to start P-touch Editor 5.0.

■ Installing the BRAdmin Light configuration utility

The BRAdmin Light is a utility for initial setup of Brother network connected devices. It can also search for Brother products on your network, view the status and configure basic network settings, such as IP address. For more information on BRAdmin Light, visit us at <http://solutions.brother.com/>

Note

- If you require more advanced printer management, use the latest Brother BRAdmin Professional utility version that is available as a download from <http://solutions.brother.com/>
- If you are using personal firewall software, BRAdmin Light may fail to detect the unconfigured device. In that case, disable your personal firewall software, and try using BRAdmin Light again. Restart your personal firewall software after the address of the unconfigured device is set.

1 Click [Utility Installation].

This screen is the same screen as you see when you insert the CD-ROM.

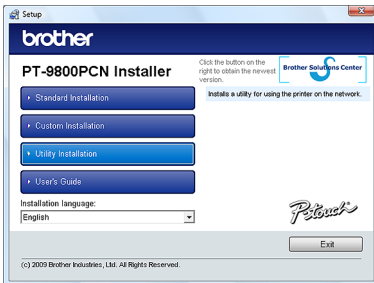

2 Click [BRAdmin Light] and follow the on-screen instructions.



If the Windows Firewall is enabled on your computer, the message “Do you wish to add this application to the list of exceptions?” appears. Check your computer environment and choose [Yes] or [No].



■ Setting your IP address, Subnet Mask and Gateway using BRAdmin Light

1 Click “Start” - “All Programs (Programs)” - “Brother” - “BRAdmin Light”.

BRAdmin Light will search for new devices automatically.

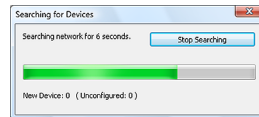

Note

- If you have a DHCP/BOOTP/RARP server in your network, you don't have to do the following operation, because the print server will automatically obtain its IP address.

2 Double-click the unconfigured device.

The default password is “access”.

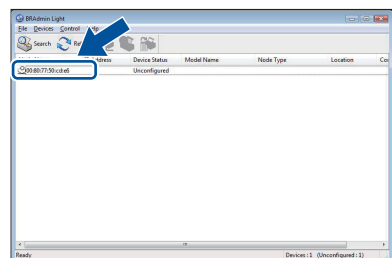

- 3** Choose **STATIC** for the Boot Method. Enter the IP Address, Subnet Mask and Gateway, and then click [OK].

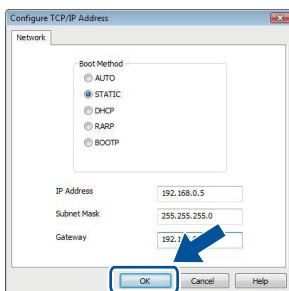

- 4** The address information will be saved to the printer.

When using Mac OS®

This section explains how to install P-touch Editor 5.0 and printer driver.

Note

- Do not connect the printer to your Macintosh® before P-touch Editor 5.0 installation has been completed.
- You must be logged on as a user with administrator privileges to install this software.
- Turn off the printer with the power button and then with the main power switch.

The screens are from Mac OS® X 10.5.7.

- 1** Start up the Macintosh®, and insert the CD-ROM into the CD-ROM drive. Double-click the "PT_Series" (CD-ROM) icon.



- 2** Double-click "Brother PT-9800PCN Driver.pkg" in the "Mac OS X" folder. The Driver Installer starts up. Follow the on-screen instructions.



- 3** After the installation is completed and the screen shown below is displayed, click [Close].

The installation of the printer driver is completed.

Next, install the P-touch Editor 5.0.

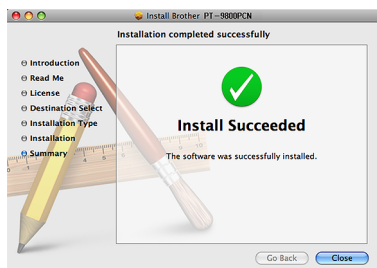

- 4** Double-click "P-touch Editor 5.0 Installer.mpkg".

The P-touch Editor 5.0 Installer starts up. Follow the on-screen instructions.



P-touch Editor 5.0
Installer.mpkg

- 5** When the installation is completed and the message "Click Restart to finish installing the software." is displayed, click [Restart].

The Macintosh® is restarted.

The installation of software is completed.

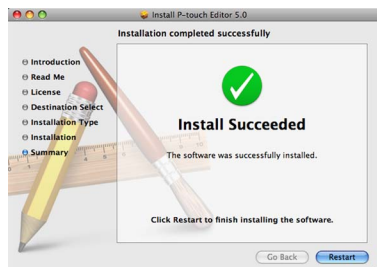

- 6** After restarting the computer, connect your printer to the computer by using the USB/LAN cable, and then turn on the printer.

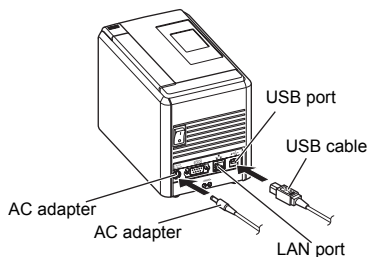

Note

- If you are connecting the printer to the Macintosh® via a USB hub, it may not be detected correctly. If so, connect the printer directly to the USB port on the Macintosh®.

- 7** For Mac OS® X 10.3.9 - 10.4.x

Double-click the drive where Mac OS® X is installed, and click "Applications" - "Utilities" - "Printer Setup Utility".

For Mac OS® X 10.5.x - 10.6

Click Apple menu - "System Preferences", and click "Print & Fax". Then click  to add your printer.

8 Choose your connection method.

- **Local Printer with USB cable**
See “For USB interface cable users”
(→ P. 26).
- **Network Shared Printer (Simple network configuration)**
Check the LAN cable is connected to the printer.
See “For network interface cable users (Simple network configuration)”
(→ P. 27).
- **Network Shared Printer (Manual network configuration)**
Check the LAN cable is connected to the printer.
See “For network interface cable users (Manual network configuration)”
(→ P. 28).

■ For USB interface cable users

- 9 For Mac OS® X 10.3.9
Click [Add] and choose “USB” at the top of the screen.
Choose “PT-9800PCN” from the list and click [Add] again to add the printer to the “Printer Setup Utility”.

For Mac OS® X 10.4.x - 10.6

- Click [Add] / [+].
Choose “PT-9800PCN/Brother PT-9800PCN” from the list and click [Add] to add the printer to the “Printer Setup Utility” / “Print & Fax”.

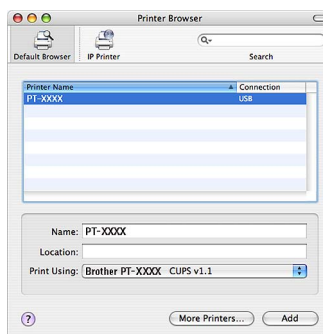

Note

- For Mac OS® X 10.4.x, click [Add] and add the printer with the BRPTUSB connection. (If you do so, an error dialog appears when an printing error occurs.) Set the appropriate printer name.

- 10 When the screen returns to the “Printer List” / “Print & Fax” screen, check that the “PT-9800PCN/Brother PT-9800PCN” is added, and close the “Printer List” / “Print & Fax” screen. Now you can use the printer.

Note

- For details on software, see the P-touch Editor Help.

■ For network interface cable users
(Simple network configuration)

9 Click [Add].

10 For Mac OS® X 10.3.9
Make the selection shown below.

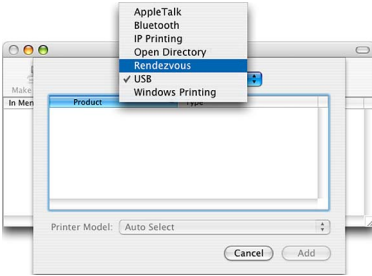

11 Choose “Brother PT-9800PCN” from the list and click [Add] again to add the printer to the “Printer Setup Utility” / “Print & Fax”.

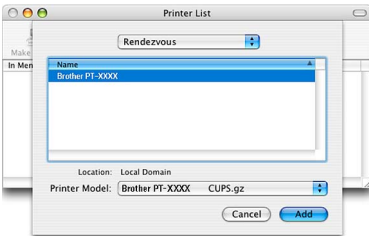

Mac OS® X 10.3.9

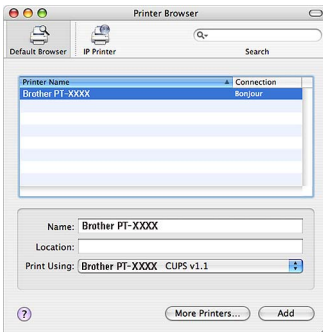

Mac OS® X 10.4.x

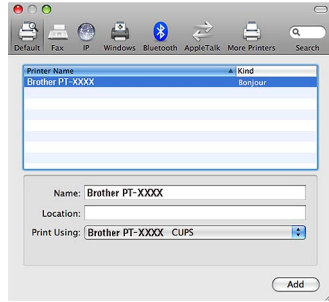

Mac OS® X 10.5.x-10.6

12 When the screen returns to the “Printer List” / “Print & Fax” screen, check that the “Brother PT-9800PCN” is added, and close the “Printer List” / “Print & Fax” screen.
Now you can use the printer.

Note

- For details on software, see the P-touch Editor Help.

■ For network interface cable users (Manual network configuration)

- 9** For Mac OS® X 10.3.9
Click [Add] and choose IP Printing at the top of the screen.
Enter the IP address of the printer into the Printer Address box. Choose “PT-9800PCN” from the list and click [Add] again to add the printer to the “Printer Setup Utility”.

For Mac OS® X 10.4.x - 10.6
Click [Add] and choose IP Printer / IP at the top of the screen.
Enter the IP address of the printer into the Address box. Choose “Brother PT-9800PCN” from the list and click [Add] again to add the printer to the “Printer Setup Utility”.

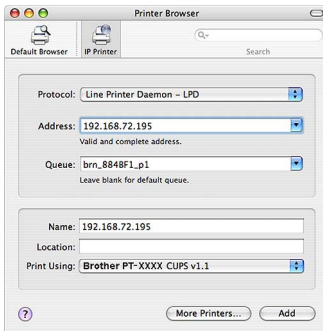

Note

- When specifying the Queue Name, choose the value BRNxxxxxxxxxxxxx (where xxxxxxxxxxxx is the Ethernet address).

- 10** When the screen returns to the “Printer List” / “Print & Fax” screen, check that the “Brother PT-9800PCN” is added, and close the “Printer List” / “Print & Fax” screen.
Now you can use the printer.

Note

- For details on software, see the P-touch Editor Help.

■ Installing the BRAdmin Light configuration utility

The BRAdmin Light is a utility for initial setup of Brother network connected devices. It can also search for Brother products on your network, view the status and configure basic network settings, such as IP address.

For more information on BRAdmin Light, visit us at <http://solutions.brother.com/>

Note

- If you are using personal firewall software, BRAdmin Light may fail to detect the unconfigured device. In that case, disable your personal firewall software, and try using BRAdmin Light again. Restart your personal firewall software after the address of the unconfigured device is set.

- 1** Double-click “BRAdmin Light.pkg” in the “Mac OS X” folder.

The BRAdmin Light Installer starts up. Follow the on-screen instructions.



BRAdmin Light.pkg

- 2** When the installation is completed and the message “The Software was successfully installed.” is displayed, click [Close].

The installation of BRAdmin Light is completed.

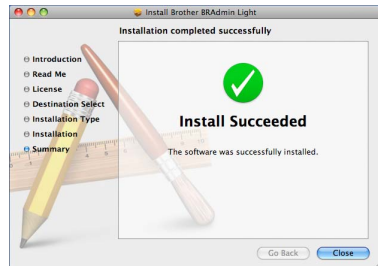

■ Setting your IP Address, Subnet Mask and Gateway using BRAdmin Light

- 1 Click “Library” - “Printers” - “Brother” - “P-touch Utilities” - “BRAdmin Light.jar”.
BRAdmin Light will search for new devices automatically.



BRAdmin Light.jar

Note

- If you have a DHCP/BOOTP/RARP server in your network, you don't have to do the following operation, as the print server will automatically obtain its IP address.

- 2 Double-click the unconfigured device.
The default password is “access”.

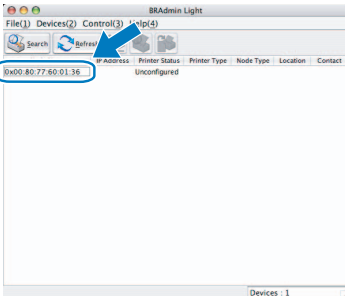

- 3 Choose “STATIC” for the “BOOT Method”. Enter the IP Address, Subnet Mask and Gateway, and then click [OK].

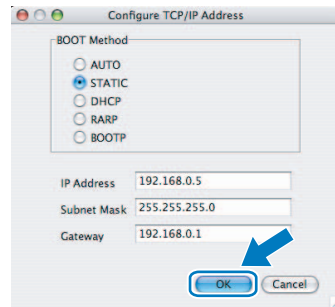

- 4 The address information will be saved to the printer.

Uninstalling the software

This section describes how to uninstall the software and printer driver. In the following steps, you will see PT-XXXX. Read “XXXX” as your printer name.

For Microsoft® Windows® users, see “When using Microsoft® Windows®” (→ P. 30).

For Macintosh® users, see “When using Mac OS®” (→ P. 31).

When using Microsoft® Windows®

■ Uninstalling P-touch Editor

- 1 For Windows® XP**
From the “Control Panel”, go to “Add or Remove Programs”.
The “Add or Remove Programs” window appears.

For Windows Vista®/Windows® 7

From the “Control Panel”, go to “Programs” and open “Programs and Features”.
The “Uninstall or change a program” window appears.

- 2 For Windows® XP**
Choose “Brother P-touch Editor 5.0”, and click [Remove].

For Windows Vista®/Windows® 7

Choose “Brother P-touch Editor 5.0”, and click [Uninstall].
When the “User Account Control” dialog box appears, click [Continue]. If a password is requested, type in the password, and then click [OK].

- 3 Click [OK].**
After the software is removed from your computer, the “Maintenance Complete” dialog box appears. Click [Finish].

- 4 Close the “Add or Remove Programs” (XP) / “Programs and Features” (Windows Vista®/Windows® 7) window.**

The P-touch Editor has been uninstalled.

Note

- Software User’s Guide (PDF) and Network User’s Guide (PDF) (PT-9800PCN only) can also be uninstalled by following the same procedure.

■ Uninstalling the printer driver

- 1 Turn off the printer.**

- 2 For Windows® XP**
From the “Control Panel”, open the “Printers and Faxes” window.

For Windows Vista®

From the “Control Panel”, go to “Hardware and Sound” and open “Printers”.

For Windows® 7

Click the , go to [Devices and Printers].

Note

- For details, see Windows® Help.

- 3 For Windows® XP**
Choose “Brother PT-XXXX”, and click “File” - “Delete” or right click on the icon and then click [Delete].

For Windows Vista®/Windows® 7

Choose “Brother PT-XXXX”, and click [Delete this printer] or right click on the icon, and then click [Delete] (Windows Vista®) / [Remove device] (Windows® 7).

- 4 For Windows® XP**
Go to “File” - “Server Properties”.
The “Print Server Properties” window appears.

For Windows Vista®

In the “Printers” window, right click and select “Run as administrator” - “Server Properties...”.
If the authorization confirmation dialog appears, click [Continue].
If the “User Account Control” dialog appears, enter the password and click [OK].
The “Print Server Properties” window appears.

For Windows® 7

Choose [Fax] or [Microsoft XPS Document Writer] in the [Devices and Printers] window, and then click [Print server properties], which appeared in the menu bar.

5 For Windows® XP

Click the “Drivers” tab and choose “Brother PT-XXXX”. Then, click [Remove].
Go to step 7.

For Windows Vista®

Click the “Drivers” tab and choose “Brother PT-XXXX”. Then, click [Remove...].

For Windows® 7

Click the [Drivers] tab, and then click [Change Driver Settings].
(If a User Account Control message appears, type in the password, and then click [OK].)
Choose “Brother XX-XXXX”, and then click [Remove...].

6 For Windows® XP

Go to step 7.

For Windows Vista®

Choose [Remove driver only] and click [OK].

For Windows® 7

Choose [Remove driver and driver package], and then click [OK].

7 Close the “Print Server Properties” window.

The printer driver has been uninstalled.

When using Mac OS®

■ Uninstalling P-touch Editor

1 On the drive where P-touch Editor is installed, double-click the “Applications” folder - “P-touch Editor 5.0” folder - “Uninstall P-touch” folder - “UninstallPtEditor.command”.

The “Terminal” window appears, and the uninstall operation starts.

Note

- Administrator privileges are required for the uninstall operation.
- In case the “Terminal” window does not appear by double-clicking the “UninstallPtEditor.command”, right click (or press control key + click) the “UninstallPtEditor.command”. The context menu appears. Open the “Terminal” window from the context menu.

2 Click to close the “Terminal” window.

3 Delete the “P-touch Editor 5.0” folder from the “Applications” folder.

Note

- Before you delete the “P-touch Editor 5.0” folder, please check if any necessary files are saved in it.

P-touch Editor has been uninstalled.

■ Uninstalling the printer driver

1 Turn off the printer.

2 For Mac OS® X 10.3.9 - 10.4.x

Double-click the drive where Mac OS® X is installed, and click “Applications” - “Utilities” - “Printer Setup Utility”.
The “Printer List” window appears.

For Mac OS® X 10.5.x - 10.6

Click Apple menu - “System Preferences”, and click “Print & Fax”.

3 For Mac OS® X 10.3.9 - 10.4.x

Choose “PT-XXXX”, and click .

For Mac OS® X 10.5.x - 10.6

Choose “Brother PT-XXXX”, and click .

4 Close the “Printer List” / “Print & Fax” window.

The printer driver has been uninstalled.

Advanced function

After the printer has been connected to the computer, labels can be created and printed. This section describes various useful print settings and how to use a bar code reader to print labels without a computer.

■ Printing labels at high speed or a high resolution

See “Printing at a higher speed or at a higher resolution” (→ P. 32)

■ Printing a large number of labels distributed to multiple printers

See “Distributed printing” (→ P. 33)

■ Printing using only a bar code reader without a computer

See “BTP (Bar code Template Print) function” (→ P. 35)

■ Creating and printing simple labels by using P-touch Editor Lite LAN (PT-9800PCN only)

See “Using P-touch Editor Lite LAN (PT-9800PCN and Windows® only)” (→ P. 40)

■ Printing a list of the current printer settings

See “Printing the printer settings” (→ P. 41)

Printing at a higher speed or at a higher resolution

The print speed and resolution can be changed depending on the combination of the type of tape being used and the selected output setting. With HG tape, labels can be printed at an even faster speed or higher resolution.

Output	Tape Type		Resolution
	TZ tape	HG tape	
High Speed (HG only)	—	80 mm/sec	360 × 180 dpi
Standard	20 mm/sec	52 mm/sec	360 × 360 dpi
High Resolution (HG Only)	—	20 mm/sec	360 × 720 dpi

- When HG tape is used, printing can be performed at a faster speed or at a higher resolution than with TZ tape.
- When HG tape is used with the “High Speed” setting selected, printing can be performed even faster. However, since the resolution in the feed direction is reduced, this is not suitable for detailed printing.
- When HG tape is used with the “High Resolution” setting selected, printing can be performed with an even higher resolution. This is suitable for detailed printing of objects such as graphics and curved lines.
- When printing bar codes, use the “Standard” setting, which has identical horizontal and vertical resolutions.

Note

- The print speeds listed above indicate the highest speeds possible. The actual speed may differ depending on the operating conditions.

Distributed printing

When printing a large number of labels, printing can be distributed among multiple printers. Since printing is performed at the same time, the total printing time can be reduced.

Note

- Printing can be distributed to printers connected via a USB connection or network connection (PT-9800PCN only).
- The number of pages to be printed is automatically divided among the selected printers. If the specified number of pages cannot be evenly divided among the printers, it will be divided in the order of the printers listed in the “Distributed Printing Settings” dialog box when the print settings are specified in step 4.

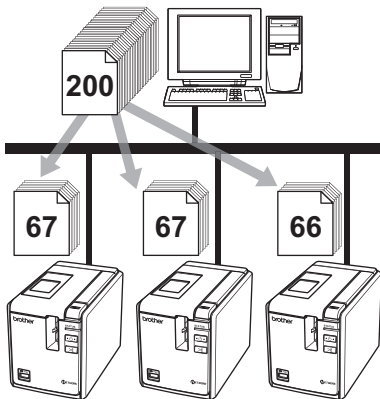

- 1 From the “File” menu in P-touch Editor 5.0, click “Print”.
- 2 Click [Properties...].

- 3 Select the “Advanced” tab, select the “Distributed printing” check box, and then click [Settings].

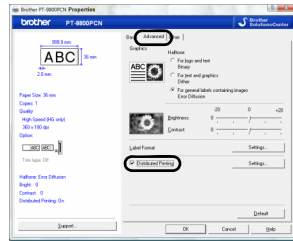

- 4 In the “Distributed Printing Settings” dialog box, select the printers to be used for distributed printing.

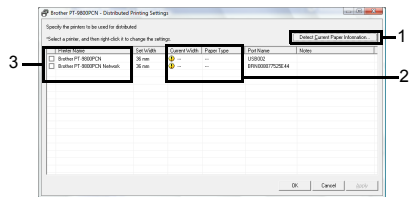

1. Click [Detect Current Paper Information].
2. The current printer information that was detected appears below “Current Width” and “Paper Type”.
3. Select the check box beside the “Printer Name” to be used for distributed printing.

5 Specify the tape width to be used for printing.

A. If only one printer has been selected.

In the dialog box from step 4, select the printer whose setting is to be specified, and then either double-click it or right-click it and click “Settings”. From the “Set Width” drop-down list, select the tape width.

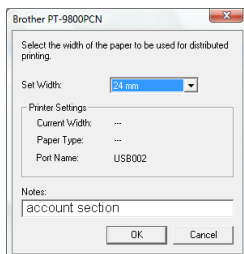

Note

- Information to be displayed in the dialog box from step 4 can be entered in the “Notes” text box.

B. If multiple printers have been selected.

In the dialog box from step 4, select the printers whose setting are to be specified, and right-click them and click “Settings”. From the “Set Width” drop-down list, select the tape width. The same tape width setting is applied to all selected printers.

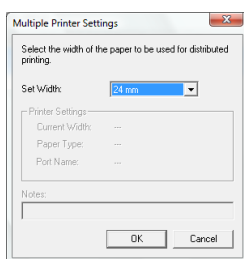

Note

- The settings below “Printer Settings” and “Notes” are not available.

6 Click [OK] to close the tape width setting window.

7 Click [OK] to close the “Distributed Printing Settings” window. Setup is completed.

8 Click [OK] to start distributed printing.

Note

- If the selected tape width is different from that displayed beside “Current Width”, a warning icon appears beside the setting below “Current Width”. Load the printer with tape of the width specified with “Set Width”.
- It may be impossible to detect information for a printer connected using the PS-9000 or any common USB hub or print server. Before printing, enter the settings manually, and check if the printer can be used for printing.
- Depending on whether a router is used and the security features in use, such as a firewall, it may not be possible to use this function.
- We recommend performing a connection test for your operating environment. For more information, contact a sales representative.

BTP (Bar code Template Print) function

With a bar code reader connected to the printer, labels and bar codes can be easily printed without a computer by scanning bar codes.

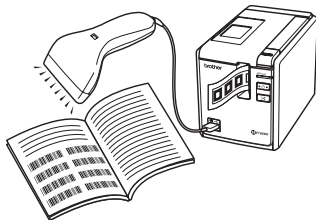

Preset template printing (→ P. 36)

If a frequently used label layout is transferred to the printer, identical labels can be printed simply by scanning the print settings and commands with a bar code reader.

Bar code printing (→ P. 37)

A bar code scanned with the bar code reader can be printed with the protocol and with the size from a previously created template.

Database-assisted label printing (→ P. 38)

An object in a P-touch Editor label layout which is connected with a database can be replaced with bar code data scanned by the bar code reader.

■ Preparation

Connect a bar code reader to the printer.

Bar code reader connection interfaces

	Bar code reader	
	RS-232	USB direct interface
PT-9700PC	Yes	No
PT-9800PCN	Yes	Yes

Bar code reader models whose operation has been confirmed

- OPR-4001
(OPTOELECTRONICS CO., LTD.)
- LS-1203 (Motorola, Inc.)
- DS 6707 (Honeywell International Inc.)

Note

- For the FAQ and up-to-date list of bar code reader models whose operation has been confirmed, visit the Brother Solutions Center (<http://solutions.brother.com/>).
- Before this function can be used, the label layout or template to be used must be transferred with the Transfer Manager from the computer to the printer. For details of the Transfer Manager, see the "Software User's Guide" (PDF).
- The bar code reader should be set for bar codes with no prefix or suffix.
- Various settings such as the baud rate must be changed in order to use the RS-232C connection. For details on changing the settings, refer to the operation manual for the bar code reader. The default settings for the serial port of this printer are listed below.

Baud rate	9600bps	Flow control	DTR
Parity	None	Stop bit	1
Bit length	8		

- To change the printer serial interface communications settings, refer to "Serial interface settings (Windows® only)" (→ P. 42) for detailed information.
- For details on using the bar code reader, contact the manufacturer.

■ Preset template printing

If a frequently used label layout is stored in the printer, identical labels can be easily printed without a computer by scanning bar codes.

<Name label>

Bill Anderson

<Address label>

Mr. Bill Anderson
4555 Cumberland Pkwy
Anytown USA 95063

Note

- For details on the various settings that can be chosen by scanning the appropriate bar code, refer to “List of bar codes for specifying settings” (→ P. 49).

1 Transfer the label layout to be printed from the P-touch Editor 5.0 to the printer by using the Transfer Manager. (See Software User’s Guide.)

Note

- A text object in the label layout can be converted to an image. After being converted to an image, the text cannot be changed. This is useful for protecting frequently used templates from being accidentally edited.
In the P-touch Editor layout window, right-click the text object, and then click “Properties”. Click the “Expanded” tab, and then select the “Text Cannot Be Edited” check box.
If you cannot see the “Expanded” tab, click “Options” in the “Tools” menu, click the “General” tab, and then select the “Display Expanded Tabs of Object Properties” check box under “Others”. When the check box is cleared, the object is converted back to text that can be edited.

2 When data is transferred to “Configurations” in Transfer Manager, the “Key Assign” number is automatically specified.

Note

- Specify a “Key Assign” number between 1 and 10 for label layouts to be used with preset template printing.

3 Scan the “P-touch template command” bar code to begin specifying the print settings.

Refer to “List of bar codes for specifying settings” (→ P. 49).

4 Specify the print settings by scanning the bar codes with the desired settings, from the “Basic Settings” bar codes.

Note

- It is possible to scan multiple settings.
- If no settings have been specified, a label will be printed with the default P-touch Template Setting (Single copy with “Auto cut on” and “Half cut on”). For details on P-touch Template Settings, download “P-touch Template manual” (English only) from the following web site:
<http://solutions.brother.com/>
Choose your region (eg. Europe), your country, your model and Downloads for your model.
- To specify the number of copies to be printed, scan the “Number of copies” bar code, and then scan the bar codes under “For entering numbers” to specify a three-digit number.
Example:
Specify numbers by scanning bar codes as follows: 7 → [00][7], 15 → [0][1][5].
- To change the setting for the number of copies, scan the “Number of copies” bar code again, and then scan the bar codes for the new three-digit number.

5 Scan the bar code under “Preset template number” with the same number as the “Key Assign” number for the label layout to be printed.

6 The specified label is printed.

■ Bar code printing

A bar code scanned with the bar code reader can be printed with the protocol and size from a previously created template.

Note

- For details on the various settings that can be chosen by scanning the appropriate bar code, refer to “List of bar codes for specifying settings” (→ P. 49).
- If the bar code to be scanned with the bar code reader has a different protocol than the bar code in the previously created template, it may not be possible to create and print the bar code.

- 1** Transfer the template to be printed from the P-touch Editor 5.0 to the printer by using the Transfer Manager. (See Software User’s Guide.)



(CODE128/9-digit/69 mm × 17 mm)

Note

- Be sure to create bar code templates that comply with the limits on the size and number of digits for the bar code to be scanned. The new bar code cannot be created if it exceeds the number of digits specified in the template.

- 2** When data is transferred to “Configurations” in Transfer Manager, the “Key Assign” number is automatically specified.

- 3** Scan the “P-touch template command” bar code to begin specifying the print settings.
Refer to “List of bar codes for specifying settings” (→ P. 49).

- 4** Specify the print settings by scanning the bar codes with the desired settings, from the “Basic Settings” bar codes.

Note

- It is possible to scan multiple settings.
- If no settings have been specified, a label will be printed with the default P-touch Template Setting (Single copy with “Auto cut on” and “Half cut on”). For details on P-touch Template Settings, download “P-touch Template manual” (English only) from the following web site:
<http://solutions.brother.com/>
Choose your region (eg. Europe), your country, your model and Downloads for your model.
- To specify the number of copies to be printed, scan the “Number of copies” bar code, and then scan the bar codes under “For entering numbers” to specify a three-digit number. The setting is automatically applied when three digits have been specified.

Example:

Specify numbers by scanning bar codes as follows: 7 → [00][7], 15 → [0][1][5].

- To change the setting for the number of copies, scan the “Number of copies” bar code again, and then scan the bar codes for the new three-digit number.

- 5** Scan the “Select template” bar code, and then scan the bar codes under “For entering numbers” to specify the “Key Assign” number (three digits) for the bar code template.

Note

- The setting is automatically applied when three digits have been specified.
Example:
Specify numbers by scanning bar codes as follows: 7 → [00][7], 15 → [0][1][5].
- To change the number, scan the “Select template” bar code again, and then scan the bar codes for the new three-digit number.

- 6 Scan the bar code whose data is to be used.



(CODE128/9-digit)

- 7 Scan the “Begin printing” bar code.

- 8 The bar code is printed with the protocol and size specified in the template.



■ Database-assisted label printing

First, a database field must be connected to an object in the label layout. Then, when a key bar code is scanned with the bar code reader, the bar code data can be printed replacing data from the connected database file in the object of the specified template.

Note

- The key bar code is the bar code for the information appearing in the database file at the leftmost column in record view (field “A” in form view). These key bar codes must be created in advance.
- The database information in field “A” of the form view must not include any other data. In addition, even if the information contains two lines of data, only the first line of data is recognised when the bar code is scanned with the bar code reader. Therefore, enter only one line of data into the information in field “A” of the form view.
- For details on the various settings that can be chosen by scanning the appropriate bar code, refer to “List of bar codes for specifying settings” (→ P. 49).

- 1 Connect the database file to the label layout to be printed.

For details on specifying the settings, refer to the “P-touch Editor Help”.

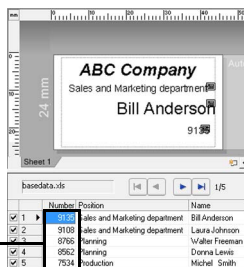

Data to be replaced by the key bar code data

- 2 Transfer the label layout to be printed from the P-touch Editor 5.0 to the printer by using the Transfer Manager. (See Software User’s Guide.)

The database file is also transferred.

- 3 When data is transferred to “Configurations” in Transfer Manager, the “Key Assign” number is automatically specified.

- 4 Scan the “P-touch template command” bar code to begin specifying the print settings.

Refer to “List of bar codes for specifying settings” (→ P. 49).

- 5 Specify the print settings by scanning the bar codes with the desired settings, from the “Basic Settings” bar codes.

Note

- It is possible to scan multiple settings.
- If no settings have been specified, a label will be printed with the default P-touch Template Setting (Single copy with “Auto cut on” and “Half cut on”). For details on P-touch Template Settings, download “P-touch Template manual” (English only) from the following web site:
<http://solutions.brother.com/>
Choose your region (eg. Europe), your country, your model and Downloads for your model.
- To specify the number of copies to be printed, scan the “Number of copies” bar code, and then scan the bar codes under “For entering numbers” to specify a three-digit number. The setting is automatically applied when three digits have been specified.
Example:
Specify numbers by scanning bar codes as follows: 7 → [00][7], 15 → [0][1][5].
- To change the setting for the number of copies, scan the “Number of copies” bar code again, and then scan the bar codes for the new three-digit number.

- 6** Scan the “Select template” bar code, and then scan the bar codes under “For entering numbers” to specify the “Key Assign” number (three digits) for the bar code template.

Note

- The setting is automatically applied when three digits have been specified.
Example:
Specify numbers by scanning bar codes as follows: 7 → [00][7], 15 → [0][1][5].
- To change the number, scan the “Select template” bar code again, and then scan the bar codes for the new three-digit number.

- 7** Scan the key bar code whose data is to be used in the database file.



- 8** Scan the “Delimiter” bar code.

- 9** Scan the “Begin printing” bar code.

- 10** The object data in the specified template is replaced with the database data, and the labels are printed.

ABC Company

Planning

Walter Freeman
8766

Using P-touch Editor Lite LAN (PT-9800PCN and Windows® only)

P-touch Editor Lite LAN is a basic version of a label-editing tool.

By copying P-touch Editor Lite LAN, installed from the enclosed CD-ROM, into a shared folder on the server, P-touch Editor Lite LAN on the server can be accessed by other network users to create labels, and print from PT-9800PCN connected to the network without installing any PT-9800PCN driver on the computer of each user.

Note

- In order for P-touch Editor Lite LAN to be used, the IP address of this printer must be correctly specified.
The IP address can be specified with a utility such as BRAAdmin Light, which can be installed from [Utility Installation] on the CD-ROM.
For details on using this utility, refer to “Setting the IP address and subnet mask” in the “Network User’s Guide” (PDF).
- On a network where the IP address is automatically assigned, for example, with DHCP, the IP address is automatically assigned when the printer is connected to the network, therefore the printer can be used immediately. However, since the IP address may change dynamically, we recommend specifying a static IP address when P-touch Editor Lite LAN is being used. For details, contact your network administrator.
- Specify the settings after consulting with your network administrator.

■ How to install P-touch Editor Lite LAN

- 1 Start the computer and put the CD-ROM into the CD-ROM drive.

Note

- If it does not start up automatically, open the files on the CD-ROM and double-click on “Setup.exe”.

- 2 Click [Custom Installation].
- 3 Click [P-touch Editor Lite LAN].
- 4 Follow the on-screen instructions.

■ How to share P-touch Editor Lite LAN

- Copy the folder containing P-touch Editor Lite LAN from the shared folder on the network to your computer.
- Start up P-touch Editor Lite LAN from the shared folder on the network.

Note

- A label created using P-touch Editor Lite LAN can only be printed from the PT-9800PCN connected to the network.

■ How to use P-touch Editor Lite LAN

- 1 Start P-touch Editor Lite LAN.



- 2 Enter the label text in P-touch Editor Lite LAN.

For example, click on the layout area and then type “Brother”.



- 3 Click on the “Print” button.



- 4 The label is printed.



Note

- P-touch Editor Lite LAN is ideal for creating simple labels. To create labels with more complex designs, use P-touch Editor 5.0.
- When using P-touch Editor Lite LAN for the first time, the “Add shortcut” dialog box appears. Select the desired location from “Start menu”, “Desktop” or “Quick Launch bar”, then put a check mark in the box, and click [OK]. You can access P-touch Editor Lite LAN from the shortcut next time.
- Since P-touch Editor Lite LAN uses the network printing method and not the driver settings, high speed printing and high resolution printing using HG tape are not available.
- Print jobs from the full version of P-touch Editor sent from another computer may interrupt your printing. P-touch Editor Lite LAN will resume printing once the print job from the full version has been completed.
- For more detailed information, see the “Software User’s Guide” (PDF).

Printing the printer settings

The printer settings page shows a report listing the printer settings and the network settings (PT-9800PCN only). You can print the printer settings page using the Feed/Cut button of the printer.

Note

- In addition to other details, the node name and Ethernet address are printed in the printer settings list.
- The default Node name of the network card in the printer is “BRNXXXXXXXXXXXXXXXX” where “XXXXXXXXXXXXXXXX” is the Ethernet address.

- 1 Make sure that the TZ or HG tape cassette is installed and the tape compartment cover is closed.**
To print the printer settings page, we recommend to use the tape wider than 24 mm.
- 2 Turn on the printer.**
- 3 Press and hold the Feed/Cut button to print out the settings.**

Serial interface settings (Windows® only)

Use the following steps to change or confirm the port and the baud rate settings on the computer and the printer. Use the same settings for the printer and computer. The following procedure is shown based on Windows Vista®.

Setting the computer baud rate

- 1 On the taskbar, click the “Start” button, and then click “Control Panel”.
- 2 Select “Printers and Other Hardware” (XP) / “Hardware and Sound” (Windows Vista®/Windows® 7) and then click “Printers and Faxes” (XP) / “Printer” (Windows Vista®/ Windows® 7).
- 3 Right-click the “Brother PT-XXXX” icon, and then select “Properties”.
- 4 Click the “Ports” tab and then select the port you use from the list. To save the settings, click [Apply].
- 5 Click the “Device Settings” tab, and “Utility...”, and then click [Properties...] that appears next to Utilities.

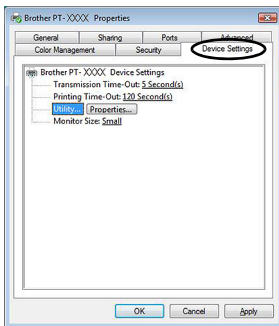

- 6 Select the desired baud rate.

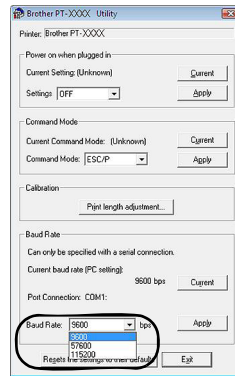

- 7 Click [Apply].
The baud rate will be changed.
- 8 Click [Exit].
- 9 Click [OK].
Setup is complete and the setting window will close.

Setting the printer baud rate

For details on the setting the printer baud rate, download “P-touch Template manual” (English only) from the following web site:
<http://solutions.brother.com/>
Choose your region (eg. Europe), your country, your model and Downloads for your model.

Maintenance

Your printer should be cleaned on a regular basis to maintain its performance.

Note

- Always disconnect the AC adapter prior to cleaning the printer.

■ Cleaning the exterior of the printer

Wipe any dust and marks from the main unit using a soft, dry cloth.
Use a slightly dampened cloth with water on difficult to remove marks.

Note

- Do not use paint thinner, benzene, alcohol or any other organic solvent. These may deform the case or damage the appearance of your printer.

■ Cleaning the print head and head roller

Streaks or poor quality characters on printed labels generally indicates that the print head and head roller are dirty. Clean the print head using a dry cotton swab, self-cleaning function or optional print head cleaning cassette (TZ-CL6).
Refer to the instructions provided with the print head cleaning cassette for directions on how to use it.

⚠ WARNING

Do not touch the print head directly with your bare hands. The print head may be hot.

□ Self-cleaning function

Remove the tape cassette, and then press the Feed/Cut button.

□ Cleaning the print head manually

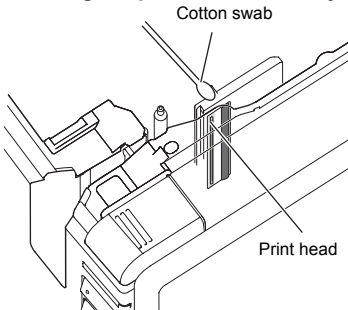

□ Cleaning the head roller manually

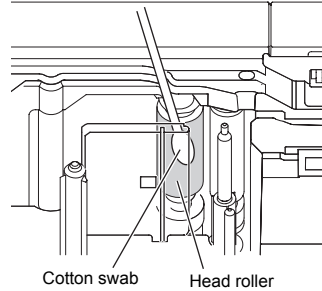

■ Cleaning the tape cutter

About once every year, wipe the cutter blades using a cotton swab moistened with isopropyl alcohol (rubbing alcohol).
Tape adhesive can build up on the cutter blade after repeated use, taking the edge of the blade which may result in the tape jamming in the cutter.

⚠ CAUTION

Do not touch the cutter blade with your finger.

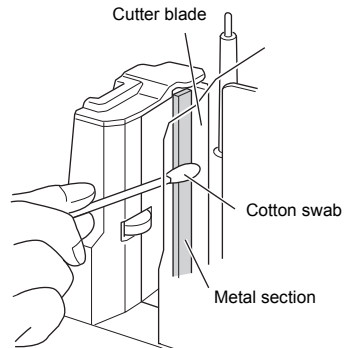

Troubleshooting

For printer troubleshooting, refer to the following list of possible problems.

Q & A

Problem	Solution
The printer does not print. A printing error is received.	Check that the interface cable is connected correctly, the tape cassette is installed correctly, and the tape compartment cover is closed.
While printing, striped tape appears.	The tape cassette is empty. Refer to "Installing the tape cassette" (→ P. 15) and install a new tape cassette.
There is about 1" of blank space at the leading edge of each printed label.	Most TZ labels have a clear laminate top layer. This durable laminate helps the label withstand abrasion, fading and wet conditions providing a crisp, readable image. The process of adding this laminate layer results in the leading edge of blank space. Adjusting the label's margin or using the chain printing feature may reduce the amount of blank space.
The power button does not light up or flash.	<ul style="list-style-type: none">• Check that the main power switch on the back of printer is on.• Check that the power supply and adapter cord is connected correctly. If the power button still does not light up or flash, contact the retail outlet where the printer was purchased or your local authorised service center.
The printed label contains a blank horizontal line.	There may be some dust on the print head. Refer to "Maintenance" (→ P. 43) and clean the print head and head roller.
After the labels are cut, they are not ejected from the printer correctly.	The cutter blade may be dirty. Refer to "Maintenance" (→ P. 43) and clean the cutter.
A data transmission error appears on the computer.	<ul style="list-style-type: none">• The wrong port may be selected. For Windows®, select the correct port from the "Print to the following port" list in the printer Properties dialog box. For a USB connection, select "USB00n".• Is someone printing via network? If you try to print while other users are printing large amounts of data, the printer is unable to accept your print job until the ongoing printing is finished. In such situations, restart the print job after the other jobs are completed.• The baud rates for the computer and the printer may not be the same. Refer to "Setting the computer baud rate" (→ P. 42) and change the baud rate.

Problem	Solution
<p>The baud rate cannot be set using the Change Baud Rate Wizard or the Brother printer utilities.</p>	<ul style="list-style-type: none"> • Error 99: The computer cannot detect the printer. <ul style="list-style-type: none"> - Make sure that the printer is turned on. - Make sure that the interface cable is connected correctly. - Make sure that the COM port where the printer is connected is the same COM port selected in the Change Baud Rate Wizard. (Many computers have more than one COM port and COM2 may have been mistakenly selected in the Change Baud Rate Wizard.) • Error 1 or Error 5: The serial port of the computer cannot be used. <ul style="list-style-type: none"> When another serial connection device is using the same COM port, labels cannot be printed. Change the COM port for the serial connection device or connect the printer to a COM port that is not being used.
<p>I want to reset the printer/delete the data transferred from computer.</p>	<p>To reset the printer, press and hold the power button to turn off the printer. Then, hold down the power button for two seconds. Continue holding down the power button, and press the Feed/Cut button six times. The printer will then reset. All the transferred data from the computer will be deleted and all printer settings will be reset to the factory settings.</p>
<p>I want to cancel the current printing job.</p>	<p>Make sure that the printer is on, and then briefly press the power button on the front of the printer.</p>
<p>Data cannot be sent from a device plugged into the USB Direct Interface on the front of the printer, or a connected device cannot be used (PT-9800PCN only).</p>	<ul style="list-style-type: none"> • The connected device is incompatible with the PT-9800PCN. <ul style="list-style-type: none"> If the LED display on USB Direct Interface is flashing in red, either the device is incompatible with the printer or the device consumes too much power. In either case, the device cannot be used with the PT-9800PCN. • The buffer of the PT-9800PCN is full. <ul style="list-style-type: none"> If the LED flashes in red while connected devices are being used, the buffer of the PT-9800PCN may have become full. Stop the data transmission, wait until the data buffered in the PT-9800PCN has been processed, and then unplug the device and plug it in again.
<ul style="list-style-type: none"> • An error occurred during installation. • Installation cannot be performed with the CD-ROM. 	<p>Visit http://solutions.brother.com/</p>
<ul style="list-style-type: none"> • I would like more information about the Add-Ins. • I do not understand how to connect to a database. 	<p>See the “Software User’s Guide” (PDF).</p>

Problem	Solution
<p>I do not understand how to install the second printer that I have purchased.</p>	<ul style="list-style-type: none"> • With a USB connection. When the printer is connected to the computer using a USB cable, the driver for the second printer is automatically installed through Plug and Play. • With a Peer-to-Peer connection (PT-9800PCN only). <ul style="list-style-type: none"> - If one PT-9800PCN is already installed: After the second printer is connected to the LAN, the installer starts up and the printer driver is installed. Both printers are listed in the dialog box where the printer can be selected. Identify the second printer by its IP address, and then select it. The selected printer driver is registered with the computer. - If multiple printers are to be installed at the same time: When the printers are connected to the LAN, the installer starts up and the printer drivers are installed. If multiple printers are selected in the list appearing in the dialog box where printers are selected, the selected printer drivers are registered with the computer.
<p>I do not understand how to share a printer on a network (PT-9800PCN only).</p>	<p>See the "Network User's Guide" (PDF).</p>

Product specifications

■ Printer specifications

Item	Specification	
Display	Power lamp (green), STATUS lamp (red), USB Direct Interface lamp (green/red) (PT-9800PCN only)	
Printing	Printing method	Heat transfer laminated printing/thermal printing
	Print head	360 dpi/384 dot
	Print resolution	For TZ tape cassettes: 360 × 360 dpi For HG tape cassettes: 360 × 180 dpi, 360 × 360 dpi or 360 × 720 dpi
	Printing speed	For TZ tape cassettes: Up to 20 mm/sec For HG tape cassettes: Up to 80 mm/sec
	Maximum printing width	27.1 mm
Buttons	Power button, Feed/Cut button	
Interface	Serial (RS-232C), USB2.0 full speed LAN (10/100BASE-TX), USB Direct Interface (PT-9800PCN only)	
Power source	AC 220 to 240 V, 50 Hz (AC adapter)	
Power consumption	Approx. 30 W (during printing)	
Measurements	116 × 193 × 140 mm (W × D × H)	
Weight	Approx. 1.58 kg	
Cutter	Auto full cutter/auto “crack and peel” cutter	

* Auto “crack and peel” cutter is available only when using laminated tape.

■ Operating environment

Item	Specification	
OS	Windows®	Windows® XP/Windows Vista®/Windows® 7, Windows Server® 2003/Windows Server® 2008/2008 R2 (for PT-9800PCN only) (Pre-installed device)
	Macintosh®	Mac OS® X 10.3.9 - 10.6
Standard Interface	Windows®	RS-232C, USB port (USB Spec. 1.1 or 2.0 protocol), (only for PT-9800PCN) 10/100BASE-TX Wired Ethernet
	Macintosh®	USB port (USB Spec. 1.1 or 2.0 protocol), (only for PT-9800PCN) 10/100BASE-TX Wired Ethernet
Hard Disk	Windows®	Disk space more than 70 MB
	Macintosh®	Disk space more than 100 MB
Memory	Windows®	Windows® XP: More than 128 MB Windows Server® 2003: More than 256 MB Windows Vista®/Windows Server® 2008/2008 R2: More than 512 MB Windows® 7: More than 1 GB (32-bit) or 2GB (64-bit)
	Macintosh®	Mac OS® X 10.3.9: More than 128 MB Mac OS® X 10.4.x: More than 256 MB Mac OS® X 10.5.x: More than 512 MB Mac OS® X 10.6: More than 1 GB
Monitor	Windows®	SVGA, high colour or higher graphics card
	Macintosh®	More than 256 colours
Others	CD-ROM drive	

General procedure for the BTP (Bar code Template Print) function

The general procedure for using the BTP (Bar code Template Print) function is described below. For details on specifying the various settings, refer to “BTP (Bar code Template Print) function” (→ P. 35).

1 Use P-touch Editor 5.0 to create a template, and then transfer it to the printer.

2 Connect the bar code reader to the printer.

3 Scan the “P-touch template command” bar code.

This allows the settings to be specified or clears the previous settings.

4 Scan the “Basic settings” bar codes.

Specify the cut method and the number of copies to be printed.

5 Specify the appropriate settings (A, B or C).

A. Preset template printing

1. Scan the “Preset template number” bar code.

B. Bar code printing

1. Scan the “Select template” bar code, then the bar codes under “For entering numbers”.

2. Scan the bar code whose data is to be used or copied.

3. Scan the “Begin printing” bar code.

C. Database-assisted label printing

1. Scan the “Select template” bar code, then the bar codes under “For entering numbers”.

2. Scan the key bar code to replace the database data.

3. Scan the “Delimiter” bar code.

4. Scan the “Begin printing” bar code.

6 The specified label is printed.

List of bar codes for specifying settings

These are the bar codes for specifying settings used with the “BTP (Bar code Template Print) function” (→ P. 35).

Note

- When using the bar codes in this list, set “Trigger for P-touch Template Printing” and “Command Prefix Character” to default in P-touch Template Settings.

■ P-touch template command (Initialize + begin specifying settings)



Escia3^II

■ Basic settings

• Auto cut on*1



^CF01

• Auto cut off



^CF00

• Half cut on*1



^CH1

• Half cut off



^CH0

• Chain printing on



^CP1

• Chain printing off*1



^CP0

• Mirror printing on



^MP1

• Mirror printing off*1



^MPO

• Number of copies*2



^CN

■ For entering numbers*2

• 1



• 3



• 5



• 7



• 9



• 00



• 2



• 4



• 6



• 8



• 0



■ Preset template number

• Preset template 1



• Preset template 3



• Preset template 2



• Preset template 4



• Preset template 5



• Preset template 6



• Preset template 7



• Preset template 8



• Preset template 9



• Preset template 10



■ Select template



■ Delimiter



■ Begin printing





*1 This is the default setting.

*2 These are used when specifying the number of copies printed and when selecting a template number.

Scan bar codes to specify a three-digit number, such as [00][7] or [0][1][5]. The setting is automatically applied when three digits have been specified.

To change settings, scan the "Number of copies" bar code again when changing the number of copies or scan the "Select template" bar code again when changing the template number, and then scan the bar codes for the new three-digit number.

Accessories

Obtain tape cassettes from your nearest authorised dealer.
 Use only Brother TZ tapes or HG tapes with this printer. Brother cannot be held responsible for trouble caused by the use of unauthorised supplies. Do not use tapes that do not have the  or  mark. Tape supply may differ by country.

■ HG tape

	Size	Description	Stock No.
High Grade type	36 mm	Black characters on white tape	HG-261
	24 mm	Black characters on white tape	HG-251
		Black characters on clear tape	HG-151
		Black characters on yellow tape	HG-651
		Black characters on matt silver tape	HG-M951
		18 mm	Black characters on white tape
	Black characters on clear tape		HG-141
	Black characters on yellow tape		HG-641
	Black characters on matt silver tape		HG-M941
	12 mm	Black characters on white tape	HG-231
		Black characters on clear tape	HG-131
		Black characters on yellow tape	HG-631
		Black characters on matt silver tape	HG-M931
	9 mm	Black characters on white tape	HG-221
		Black characters on clear tape	HG-121
		Black characters on yellow tape	HG-621
		Black characters on matt silver tape	HG-M921
	6 mm	Black characters on white tape	HG-211

■ TZ tape

	Size	Description	Stock No.
Laminated type	36 mm	Black characters on white tape	TZ-261
		Black characters on clear tape	TZ-161
		Black characters on red tape	TZ-461
		Black characters on blue tape	TZ-561
		Black characters on yellow tape	TZ-661
		Black characters on green tape	TZ-761
		Red characters on white tape	TZ-262
		Blue characters on white tape	TZ-263
		Black characters on matt silver tape	TZ-M961

	Size	Description	Stock No.
Laminated type	24 mm	Black characters on white tape	TZ-251
		Black characters on clear tape	TZ-151
		Black characters on red tape	TZ-451
		Black characters on blue tape	TZ-551
		Black characters on yellow tape	TZ-651
		Black characters on green tape	TZ-751
		Black characters on matt clear tape	TZ-M51
		Black characters on fluorescent orange tape	TZ-B51
		Black characters on fluorescent yellow tape	TZ-C51
		Black characters on fluorescent green tape	TZ-D51
		Red characters on white tape	TZ-252
		Red characters on clear tape	TZ-152
		Blue characters on white tape	TZ-253
		Blue characters on clear tape	TZ-153
		Gold characters on black tape	TZ-354
		White characters on black tape	TZ-355
		White characters on blue tape	TZ-555
		Black characters on matt silver tape	TZ-M951
	18 mm	Black characters on white tape	TZ-241
		Black characters on clear tape	TZ-141
		Black characters on red tape	TZ-441
		Black characters on blue tape	TZ-541
		Black characters on yellow tape	TZ-641
		Black characters on green tape	TZ-741
		Red characters on white tape	TZ-242
		Blue characters on white tape	TZ-243
		Gold characters on black tape	TZ-344
		White characters on black tape	TZ-345
White characters on clear tape		TZ-145	

	Size	Description	Stock No.
Laminated type	12 mm	Black characters on white tape	TZ-231
		Black characters on clear tape	TZ-131
		Black characters on red tape	TZ-431
		Black characters on blue tape	TZ-531
		Black characters on yellow tape	TZ-631
		Black characters on green tape	TZ-731
		Black characters on matt clear tape	TZ-M31
		Black characters on fluorescent orange tape	TZ-B31
		Black characters on fluorescent yellow tape	TZ-C31
		Black characters on fluorescent green tape	TZ-D31
		Red characters on white tape	TZ-232
		Red characters on clear tape	TZ-132
		Blue characters on white tape	TZ-233
		Blue characters on clear tape	TZ-133
		Gold characters on black tape	TZ-334
		White characters on black tape	TZ-335
		White characters on clear tape	TZ-135
		White characters on red tape	TZ-435
		White characters on blue tape	TZ-535
	White characters on green tape	TZ-735	
	Black characters on matt silver tape	TZ-M931	
	9 mm	Black characters on white tape	TZ-221
		Black characters on clear tape	TZ-121
		Black characters on red tape	TZ-421
		Black characters on blue tape	TZ-521
		Black characters on yellow tape	TZ-621
		Black characters on green tape	TZ-721
		Red characters on white tape	TZ-222
		Blue characters on white tape	TZ-223
		White characters on black tape	TZ-325
	6 mm	Black characters on white tape	TZ-211
		Black characters on clear tape	TZ-111
Black characters on yellow tape		TZ-611	
White characters on black tape		TZ-315	

	Size	Description	Stock No.
Non-Laminated type	24 mm	Black characters on white tape	TZ-N251
	18 mm	Black characters on white tape	TZ-N241
		Black characters on heart tape	TZ-PH41
		Black characters on fruit tape	TZ-PF41
		Black characters on marine tape	TZ-PM41
	12 mm	Black characters on white tape	TZ-N231
	9 mm	Black characters on white tape	TZ-N221
	6 mm	Black characters on white tape	TZ-N211
3.5 mm	Black characters on white tape	TZ-N201	
Strong Adhesive type	36 mm	Black characters on white tape	TZ-S261
		Black characters on yellow tape	TZ-S661
	24 mm	Black characters on white tape	TZ-S251
		Black characters on clear tape	TZ-S151
		Black characters on yellow tape	TZ-S651
	18 mm	Black characters on white tape	TZ-S241
		Black characters on clear tape	TZ-S141
		Black characters on yellow tape	TZ-S641
	12 mm	Black characters on white tape	TZ-S231
		Black characters on clear tape	TZ-S131
		Black characters on yellow tape	TZ-S631
	9 mm	Black characters on white tape	TZ-S221
		Black characters on clear tape	TZ-S121
		Black characters on yellow tape	TZ-S621
	6 mm	Black characters on white tape	TZ-S211
		Black characters on clear tape	TZ-S111
		Black characters on yellow tape	TZ-S611

	Size	Description	Stock No.
Flexible ID type	36 mm	Black characters on white tape	TZ-FX261
		Black characters on yellow tape	TZ-FX661
	24 mm	Black characters on white tape	TZ-FX251
		Black characters on yellow tape	TZ-FX651
	18 mm	Black characters on white tape	TZ-FX241
		Black characters on yellow tape	TZ-FX641
	12 mm	Black characters on white tape	TZ-FX231
		Black characters on yellow tape	TZ-FX631
	9 mm	Black characters on white tape	TZ-FX221
		Black characters on yellow tape	TZ-FX621
	6 mm	Black characters on white tape	TZ-FX211
		Black characters on clear tape	TZ-FX111
Black characters on yellow tape		TZ-FX611	
Fabric type	18 mm	Blue characters on white tape	TZ-FA4
	12 mm	Blue characters on white tape	TZ-FA3
Security type	18 mm	Black characters on white tape	TZ-SE4
Stencil type	36 mm		TZ-ST161
	24 mm		TZ-ST151
	18 mm		TZ-ST141
Cleaning tape	36 mm		TZ-CL6

Index

A

- AC adapter 7, 12
- AC adapter socket..... 8

B

- Bar code printing 37
- Bar code Template Print 35
- Bar codes for specifying settings 49
- Baud rate..... 42
- BRAdmin Light 23
- BTP 35

C

- CD-ROM 7
- Cleaning the exterior of the printer 43
- Cleaning the print head and head roller 43
- Cleaning the tape cutter 43
- Connecting to a computer 13
- Connecting to the power source 12
- Cover release button 8, 15

D

- Database-assisted label printing 38
- Default Serial settings 35
- Deleting data transferred to the printer 45
- Distributed printing 33

F

- Factory settings 45
- Feed/Cut button 8

G

- General precautions 5

H

- HG Tapes 15
- High resolution printing 32
- High speed printing 32

I

- Installing the BRAdmin Light 23, 28
- Installing the software 16, 20
- Installing the tape cassette..... 15
- Interface cables 14

L

- Label outlet 8
- LAN port..... 8
- LED lamp 9

M

- Main power switch 8, 12
- Maintenance 43

N

- Network cable 14

O

- Operating environment 47

P

- Power button 8, 12
- Power supply cord 7, 12
- Preset template printing 36
- Printer Settings print out 41
- Printing the printer settings 41
- Printing without computer 35
- P-touch Editor Lite LAN 40

Q

- Q & A 44

R

- Reset to factory settings 45

S

- Safety precautions 3
- Serial cable 14
- Serial interface settings..... 42
- Serial port..... 8
- Specifications 47
- STATUS lamp 8

T

- Tape cassette 7
- Tape compartment cover 8
- Troubleshooting 44
- TZ Tapes..... 15

U

Uninstalling the software	30
USB cable	7, 14
USB Direct Interface	8
USB port.....	8
User's Guide	7

brother®

Printed in China
LW5581001[Ⓐ]

