

At your side.
brother®

USER'S GUIDE

DCP-8040

DCP-8045D



At your side.
brother®
Version B



“EC” Declaration of Conformity

Manufacturer

Brother Industries Ltd.,
15-1, Naeshiro-cho, Mizuho-ku,
Nagoya 467-8561, Japan

Plant

Brother Corporation (Asia) Ltd.,
Brother Buji Nan Ling Factory,
Gold Garden Ind., Nan Ling Village,
Buji, Rong Gang, Shenzhen, China

Herewith declare that:

Products description : Laser Printer
Product Name : DCP-8040, DCP-8045D

are in conformity with provisions of the Directives applied : Low Voltage Directive 73/23/EEC (as amended by 93/68/EEC) and the Electromagnetic Compatibility Directive 89/336/EEC (as amended by 91/263/EEC and 92/31/EEC and 93/68/EEC).

Standards applied :

Harmonized : Safety : EN60950:2000

EMC : EN55022:1998 Class B
EN55024:1998 / A1: 2001
EN61000-3-2: 2000
EN61000-3-3: 1995

Year in which CE marking was first affixed : 2004

Issued by : Brother Industries, Ltd.

Date : 2nd February, 2004

Place : Nagoya, Japan

Signature :





Takashi Maeda
Manager
Quality Management Group
Quality Management Dept.
Information & Document Company

Safety precautions

To use the DCP safely

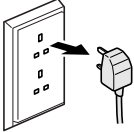
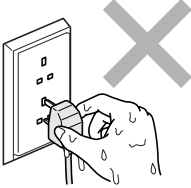
Save these instructions for later reference.

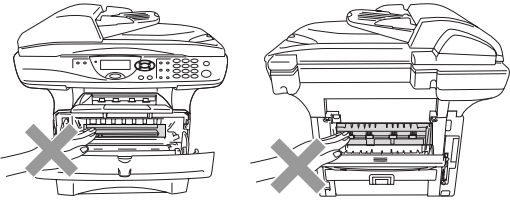
WARNING

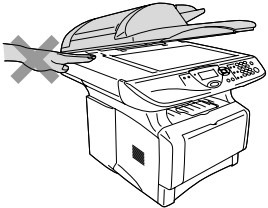
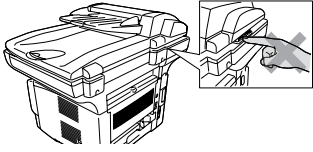
	<p>There are high voltage electrodes inside the machine. Before you clean the DCP or clear a paper jam, make sure you have unplugged the power cord from the power outlet.</p>  <p>(Example for U.K.)</p>	<p>Do not handle the plug with wet hands. Doing this might cause an electrical shock.</p>  <p>(Example for U.K.)</p>
	<p>After you use the DCP, some internal parts are extremely HOT! To prevent injuries, be careful not to put your fingers in the area shown in the illustration.</p> 	
	<p>To prevent injuries, be careful not to put your hands on the edge of the DCP under the document cover.</p> 	<p>To prevent injuries, be careful not to put your fingers in the area shown in the illustration.</p> 

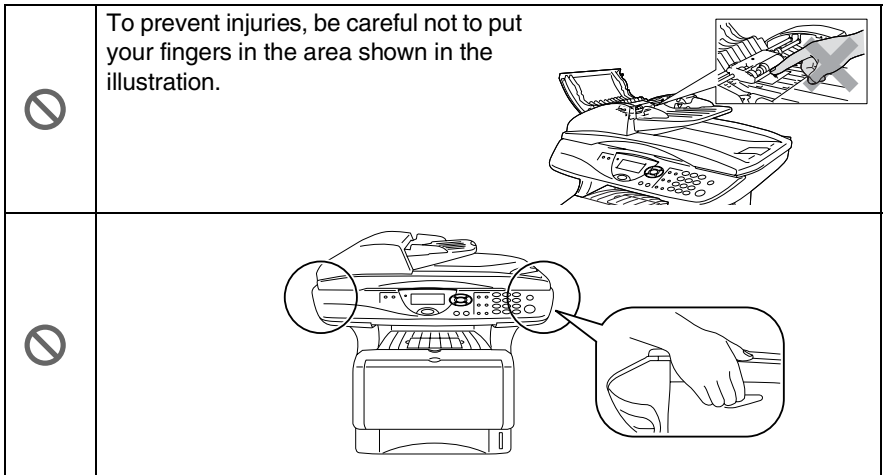

- When you move the DCP, grasp the side handholds that are under the scanner. Do NOT carry the DCP by holding it at the bottom.
- Install equipment with a power cord near a socket/outlet that is easily accessible.
- Do not use this product near appliances that use water, in a wet basement or near a swimming pool.

 **Caution**

- Lightning and power surges can damage this product! There may be a remote risk of electric shock from lightning. We recommend that you use a quality surge protection device on the AC power line, or unplug the line during a lightning storm.

Choosing a location

Place your DCP on a flat, stable surface that is free of vibration and shocks, such as a desk. Put the DCP near a telephone socket and a standard, grounded power outlet. Choose a location where the temperature remains between 10° and 32.5°C.

Caution

- Do not place near heaters, air conditioners, water, chemicals, or refrigerators.
- Do not expose the DCP to direct sunlight, excessive heat, moisture, or dust.
- Do not connect your DCP to electrical outlets controlled by wall switches or automatic timers.
- Disruption of power can wipe out information in the DCP's memory.
- Do not connect your DCP to electrical outlets on the same circuit as large appliances or other Equipment that might disrupt the power supply.
- Avoid interference sources, such as speakers or the base units of cordless phones.

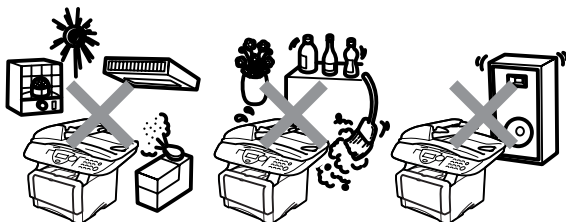

Table of Contents

1

Introduction	1-1
Using this Guide	1-1
Finding information	1-1
Symbols used in this Guide	1-1
DCP part names and operations	1-2
Control panel overview	1-6
Status LED indications	1-8
Inserting Originals for copying (and scanning)	1-10
Using the ADF (automatic document feeder)	1-10
Using the scanner glass	1-12

2

Paper	2-1
About paper	2-1
Type and size of paper	2-1
Recommended paper	2-1
Choosing acceptable paper	2-2
Paper capacity of the paper trays	2-3
Paper specifications for each paper tray	2-4
How to load paper	2-5
To load paper or other media in the paper tray	2-5
To load paper or other media in the manual feed tray (For DCP-8040)	2-7
To load paper or other media in the multi-purpose tray (MP tray) (For DCP-8045D)	2-9
To use Automatic Duplexing for copy and print operations (For DCP-8045D)	2-11

3

On-screen programming	3-1
User-friendly programming	3-1
Menu table	3-1
Navigation keys	3-2
Key Operations table	3-11

4

Getting started	4-1
General Setup	4-1
Setting the Paper Type	4-1
Setting the Paper Size	4-3
Setting the Beeper Volume	4-4
Toner Save	4-4
Sleep Time	4-5
Turning off the Scanner Lamp	4-5

Power Save	4-6
Setting the Tray Use for Copy mode	4-7
Setting the LCD Contrast.....	4-8
Printing the System Setup List.....	4-8

5

Making copies	5-1
Using the DCP as a copier	5-1
Printable area	5-1
Temporary copy settings	5-2
Making a single copy from the ADF.....	5-3
Making multiple copies from the ADF	5-3
Single or multiple copies using the scanner glass	5-4
Out of Memory message	5-5
Using the Copy keys (Temporary settings).....	5-6
Enlarge/Reduce.....	5-7
Quality (type of document).....	5-9
Sorting copies using the ADF	5-9
Contrast	5-10
Tray Select.....	5-11
Duplex/N in 1	5-12
Duplex/N in 1 copy.....	5-14
N in 1 copy.....	5-14
Poster	5-16
Duplex (1 in 1) (For DCP-8045D)	5-17
Duplex (2 in 1) and Duplex (4 in 1) (For DCP-8045D)	5-19
Changing the default copy settings.....	5-20
Quality	5-20
Contrast	5-20

6

Important information	6-1
IEC 60825 Specification	6-1
Laser Diode	6-1
Caution	6-1
For your safety.....	6-2
Disconnect device.....	6-2
IT power system (For Norway only).....	6-2
LAN connection	6-2
International ENERGY STAR® Compliance Statement	6-2
Ratio interference (220-240V Model Only)	6-3
Important safety instructions.....	6-4
Trademarks.....	6-6

7

Troubleshooting and routine maintenance	7-1
Troubleshooting	7-1
Error messages	7-1
Document jams.....	7-4
Document is jammed in the top of the ADF unit.	7-4
Document is jammed inside the ADF unit.	7-4
Paper jams	7-5
Paper is jammed in the duplex tray (For DCP-8045D)	7-9
If you are having difficulty with your DCP	7-11
Improving the print quality	7-14
Packing and shipping the DCP	7-18
Routine maintenance.....	7-21
Cleaning the scanner.....	7-21
Cleaning the printer	7-22
Cleaning the drum unit	7-23
Replacing the toner cartridge	7-24
How to replace the toner cartridge	7-24
Replacing the drum unit.....	7-29
Checking the drum life.....	7-32
Page Counter	7-32

8

Optional accessories	8-1
Memory board	8-1
Installing the optional memory board.....	8-2
Network (LAN) board.....	8-5
Before starting installation	8-6
Step 1: Hardware installation.....	8-6
Step 2: Connecting the NC-9100h to an Unshielded Twisted Pair 10BASE-T or 100BASE-TX Ethernet Network	8-9
LED	8-9
TEST SWITCH	8-10
Paper Tray #2.....	8-11

G

Glossary	G-1
-----------------------	------------

S

Specifications	S-1
Product description	S-1
General	S-1
Print media.....	S-2
Copy	S-2
Scanner	S-3
Printer	S-4
Interfaces	S-4
Computer requirements	S-5
Consumable items	S-6
Network (LAN) board (NC-9100h)	S-7
Optional External Wireless Print/Scan Server (NC-2200w)	S-8

I

Index	I-1
--------------------	------------

1 Introduction

Using this Guide

Thank you for buying a Brother Digital Copier Printer (DCP). Your DCP-8040 or DCP-8045D is simple to use, with LCD screen instructions to guide you through programming it. You can make the most of your DCP by taking a few minutes to read this Guide.

Finding information

All the chapter headings and sub-headings are listed in the Table of Contents. You will be able to find information about a specific feature or operation by checking the Index at the back of this Guide.

Symbols used in this Guide

Throughout this Guide you'll see special symbols alerting you to important warnings, notes and actions. To make things clearer and to help you press the correct keys, we have used special fonts and added some of the messages that will appear in the LCD.

Bold Bold typeface identifies specific keys on the DCP control panel.

Italics Italicized typeface emphasizes an important point or refers you to a related topic.

`Courier New` Courier New typeface identifies the messages on the LCD of the DCP.

 Warnings inform you what to do to avoid possible personal injury or damage to the DCP.

 Cautions specify procedures you must follow or avoid to prevent possible damage to the machine.

 Notes tell you how you should respond to a situation that may arise or give tips about how the current operation works with other features.

 Improper Setup alerts you to devices and operations that are not compatible with the DCP.

DCP part names and operations

■ Front view

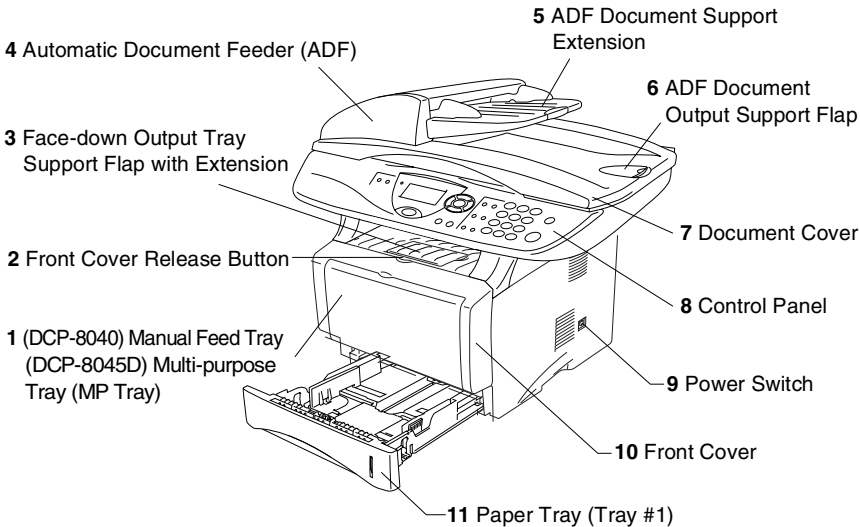

No.	Name	Description
1	(DCP-8040) Manual Feed Tray (DCP-8045D) Multi-purpose Tray (MP Tray)	Load paper here.
2	Front Cover Release Button	Press it to open the front cover.
3	Face-down Output Tray Support Flap with Extension (Support Flap)	Unfold it to prevent the printed paper from sliding off the DCP.
4	Automatic Document Feeder (ADF)	Use the ADF unit for multiple page documents.
5	ADF Document Support Extension	Place the document here to use the ADF unit.

No.	Name	Description
6	ADF Document Output Support Flap	Unfold to prevent the scanned pages from sliding off the DCP.
7	Document Cover	Open to place the document on the scanner glass.
8	Control Panel	Use the keys and display to control the DCP.
9	Power Switch	Switch it on or off.
10	Front Cover	Open to install a toner cartridge or drum unit.
11	Paper Tray (Tray #1)	Load paper here.

■ Back view

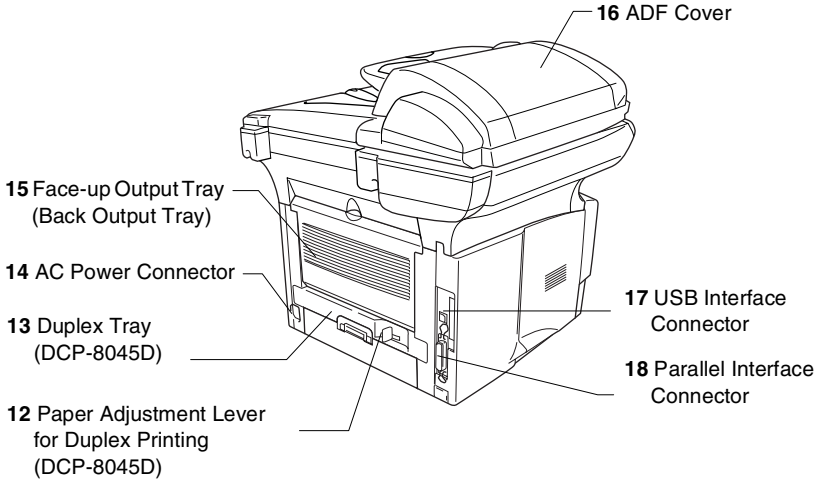

No.	Name	Description
12	Paper Adjustment Lever for Duplex Printing (DCP-8045D)	Use to match your paper size for duplex printing.
13	Duplex Tray (DCP-8045D)	Slide out to remove paper jammed inside the DCP.
14	AC Power Connector	Connect the AC Power Cable here.
15	Face-up Output Tray (Back Output Tray)	Open it when thicker paper is placed in the MP tray or Manual feed tray.
16	ADF Cover	Open to remove paper jammed inside the ADF unit.
17	USB Interface Connector	Connect the USB Cable here.
18	Parallel Interface Connector	Connect the Parallel Cable here.

■ Inside view (Document cover open)

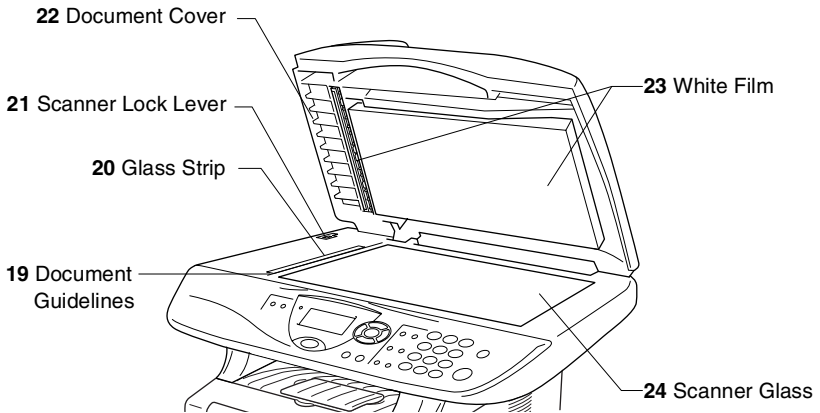

No.	Name	Description
19	Document Guidelines	Use to center the document on the scanner glass.
20	Glass Strip	This is used to scan documents when using the ADF.
21	Scanner Lock Lever	Use to lock/unlock the scanner when relocating the DCP.
22	Document Cover	Open to place the document on the scanner glass.
23	White Film	Clean it for good quality copying and scanning.
24	Scanner Glass	Place the document to be scanned here.

Control panel overview

DCP-8040 and DCP-8045D have similar control panel keys.

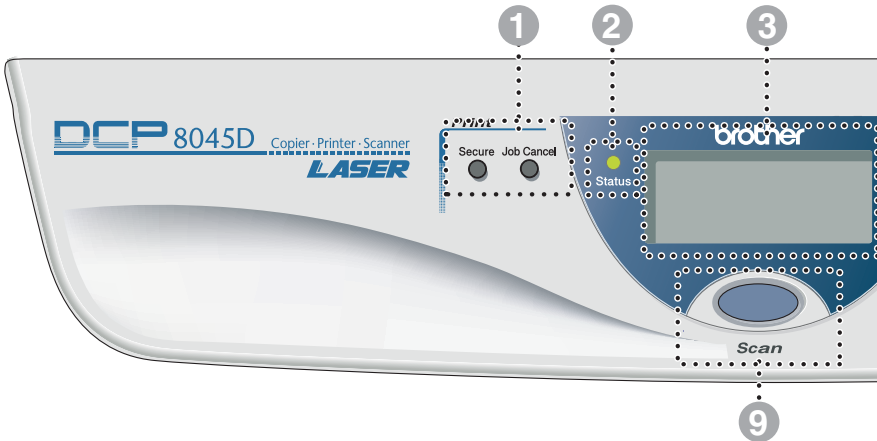

1 Print keys:

Secure

Lets you print out data saved in memory by entering your four-digit password.

Job Cancel

Clears data from the printer memory.

2 Status LED

(Light-Emitting Diode)

The LED will flash and change color depending on the DCP status.

3 5-Line Liquid Crystal Display (LCD)

Displays messages on the screen to help you to set up and use your DCP.

4 Navigation keys:

Menu

Lets you access the Menu to program.

Set

Lets you store your settings in the DCP.

Clear/Back

Deletes entered data or lets you exit the menu by pressing repeatedly.



Press to scroll forward or backward to a menu selection.

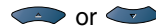

Press to scroll through the menus and options.

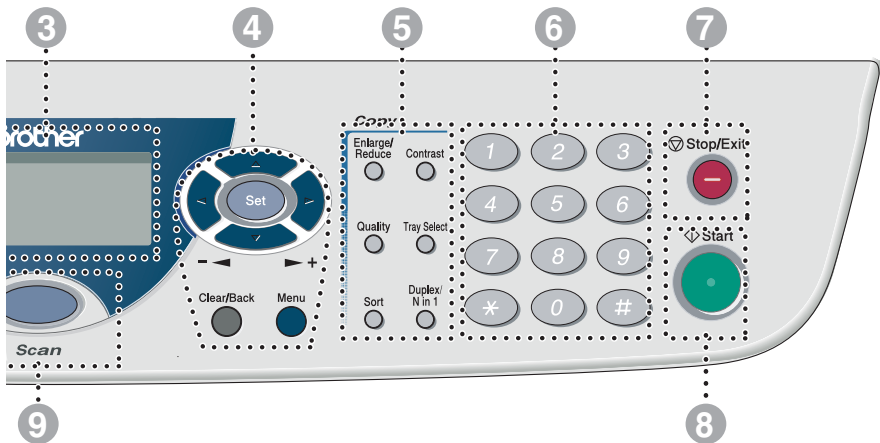

5 Copy keys

(Temporary Settings):

Enlarge/Reduce

Lets you reduce or enlarge copies depending upon the ratio you select.

Contrast

Lets you make a copy that is lighter or darker than the original.

Quality

Lets you select the copy quality for your type of original.

Tray Select

You can select which tray you would like to use for the next copy.

Sort

Lets you sort multiple copies using the ADF.

N in 1 (For DCP-8040)

N in 1 lets you copy 2 or 4 pages onto one page.

Duplex/N in 1 (For DCP-8045D)

You can choose Duplex to copy on both sides of the paper or N in 1 to copy 2 or 4 pages onto one page.

6 Numeric keys

Use the numeric keys to enter the number of multiple copies (99 maximum).

7  Stop/Exit

Stops a copy and scan operation or exits from the menu.

8  Start

Lets you start making copies or scanning.

9  Scan key:





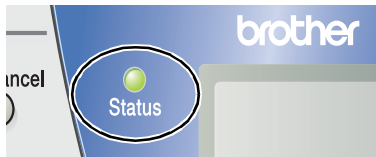

Lets you access Scan mode.





Status LED indications



The **Status** LED (Light Emitting Diode) will flash and change color depending on the DCP status.



The LED indications shown in the table below are used in the illustrations in this chapter.

LED				LED status
				LED is off.
	 Green	 Yellow	 Red	LED is on.
	 Green	 Yellow	 Red	LED is blinking.

LED	DCP status	Description
	Sleep Mode	The power switch is off or the DCP is in Sleep mode or Power save mode.
 Green	Warming Up	The DCP is warming up for printing.
 Green	Ready	The DCP is ready to print.
 Yellow	Receiving Data	The DCP is either receiving data from the computer, processing data in memory or printing data.
 Yellow	Data Remaining in Memory	Print data remains in the DCP memory.

LED	DCP status	Description
 Red	Service error	Follow the steps below. 1. Turn off the power switch. 2. Wait a few seconds, and then turn it back on and try to print again. If you cannot clear the error and see the same service call indication after turning the DCP back on, call your dealer or Brother authorized service center.
 Red	Cover open	The cover is open. Close the cover. (See <i>Error messages</i> on page 7-1.)
	Toner empty	Replace the toner cartridge with a new one. (See <i>Replacing the toner cartridge</i> on page 7-24.)
	Paper error	Put paper in the tray or clear the paper jam. Check the LCD message. (See <i>Troubleshooting and routine maintenance</i> on page 7-1.)
	Scan lock	Check that the scanner lock lever is released. (See <i>Scanner Lock Lever</i> on page 1-5.)
	Others	Check the LCD message. (See <i>Troubleshooting and routine maintenance</i> on page 7-1.)
	Out of memory	Memory is full. (See <i>Error messages</i> on page 7-1.)

Inserting Originals for copying (and scanning)

You can copy from either the ADF (automatic document feeder) or from the scanner glass.

Using the ADF (automatic document feeder)

The automatic document feeder (ADF) can hold up to 50 pages, feeding each one individually through the DCP. Use standard (75 g/m²) paper when using the ADF. Always fan the pages well and stagger them.

Temperature: 20°C - 30°C

Humidity: 50% - 70%

- ! DO NOT use curled, wrinkled, folded, or ripped paper, or paper with staples, paper clips, paste or tape attached. DO NOT use cardboard, newspaper, or fabric. (To copy or scan this kind of document, see *Using the scanner glass* on page 1-12.)

Make sure originals written with ink are completely dry.

- 1 Pull out the ADF document support extension.
- 2 Unfold the ADF document output support flap.
- 3 Fan the pages well and stagger them at an angle. Make sure you put the documents **face up, top edge first** in the ADF until you feel them touch the feed roller.

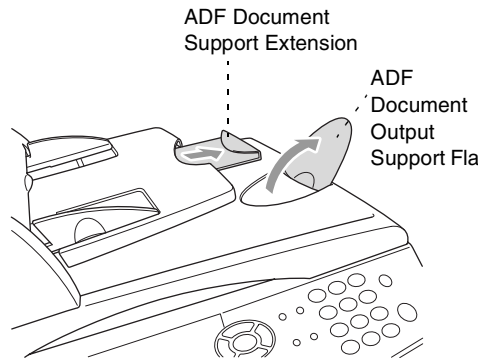

- 4** Adjust the paper guides to fit the width of your documents.

**The documents
are Face Up
in the ADF**

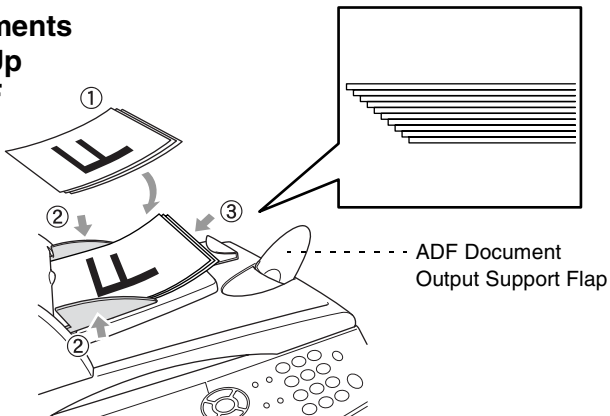

- 5** Press **Start**. The DCP starts scanning the first page.

Using the scanner glass

You can use the scanner glass to copy one page at a time, or pages of a book. To use the scanner glass, the ADF must be empty. You can make multiple copies; however, if you want them sorted you must use the ADF.

- 1 Lift the Document Cover.

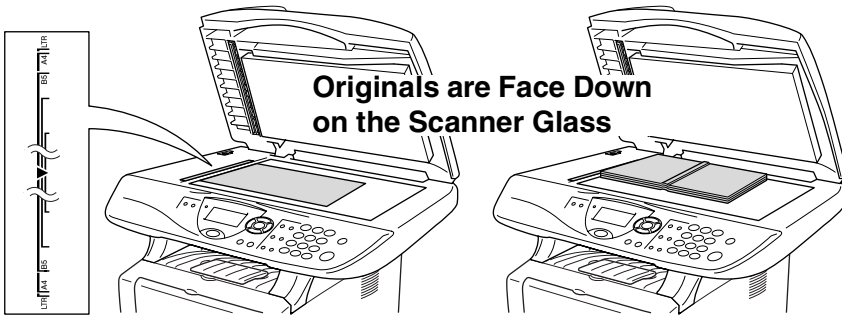

- 2 Using the document guidelines on the left, center the original face down on the scanner glass and close the document cover.
- 3 Using the numeric keys, enter the number of copies you want (up to 99).
- 4 Press **Start**.

The DCP will start scanning the original.

- ! If the original is a book or is thick, do not slam the cover or press on it or you may damage the DCP.

2 Paper

About paper

Type and size of paper

The DCP loads paper from the installed paper tray, manual feed tray, multi-purpose tray or optional lower tray.

Tray Type	Model name
Paper tray (Tray #1)	DCP-8040 and DCP-8045D
Manual feed tray	DCP-8040
Multi-purpose tray (MP tray)	DCP-8045D
Optional lower tray (Tray #2)	Option for DCP-8040 and DCP-8045D

Recommended paper

Plain Paper: Xerox Premier 80 g/m²
Xerox Business 80 g/m²
Mode DATACOPY 80 g/m²
IGEPA X-Press 80 g/m²

Recycled paper: Xerox Recycled Supreme

Transparency: 3M CG 3300

Labels: Avery laser label L7163

- Before you buy a large amount of paper, please test some to make sure that the paper is suitable.
- Use paper that is made for plain-paper copying.
- Use paper that is 75 to 90 g/m².
- Use neutral paper. Do not use acidic or alkaline paper.
- Use long-grain paper.
- Use paper with a moisture content of approximately 5%.

Caution

Do not use ink jet paper. It may cause a paper jam and damage your DCP.



The output quality depends on the paper type and paper brand. Visit us at <http://solutions.brother.com> and check the latest recommendations for paper that can be used with the DCP-8040 and DCP-8045D.

Choosing acceptable paper

We recommend that you test paper (especially special sizes and types of paper) on the DCP before purchasing large quantities.

- Avoid feeding label sheets that are partly used or your DCP will be damaged.
- Avoid using coated paper, such as vinyl coated paper.
- Avoid using preprinted or highly textured paper, or paper with an embossed letterhead.

For optimum printing, use a recommended type of paper, especially for plain paper and transparencies. For more information on paper specifications, call your nearest authorized sales representative or the place where you purchased your DCP.

- Use label or transparencies that are designed for use in *laser* printers.
- For the best print quality, we recommend using long-grained paper.
- If you are using special paper and the paper has problems feeding from the paper tray, try again using the manual feed tray or Multi-purpose tray.
- You can use recycled paper in this DCP.

Paper capacity of the paper trays

	Paper size	Number of sheets
Multi-purpose tray (MP tray) (DCP-8045D)	Width: 69.8 to 220 mm Height: 116 to 406.4 mm	50 sheets (80 g/m ²)
Manual feed tray (DCP-8040)	Width: 69.8 to 220 mm Height: 116 to 406.4 mm	Single sheet
Paper tray (Tray #1)	A4, Letter, Legal, B5 (ISO), B5 (JIS), Executive, A5, A6, B6 (ISO)	250 sheets (80 g/m ²)
Optional lower tray (Tray #2)	A4, Letter, Legal, B5 (ISO), B5 (JIS), Executive, A5, B6 (ISO)	250 sheets (80 g/m ²)
Duplex printing (DCP-8045D)	A4, Letter, Legal	—

Paper specifications for each paper tray

Model		DCP-8040	DCP-8045D
Paper types	Multi-purpose tray	N/A	Plain paper, Bond paper, Recycled paper, Envelope* ¹ , Labels* ² , and Transparency* ²
	Manual feed tray	Plain paper, Bond paper, Recycled paper, Envelope, Labels, and Transparency	N/A
	Paper tray	Plain paper, Recycled paper, and Transparency* ²	
	Optional Lower tray	Plain paper, Recycled paper, and Transparency* ²	
Paper weights	Multi-purpose tray	N/A	60 to 161 g/m ²
	Manual feed tray	60 to 161 g/m ²	N/A
	Paper tray	60 to 105 g/m ²	
	Optional Lower tray	60 to 105 g/m ²	
Paper sizes	Multi-purpose tray	N/A	Width: 69.8 to 220 mm Height: 116 to 406.4 mm
	Manual feed tray	Width: 69.8 to 220 mm Height: 116 to 406.4 mm	N/A
	Paper tray	A4, Letter, Legal, B5 (ISO), B5 (JIS), Executive, A5, A6, B6 (ISO)	
	Optional Lower Tray	A4, Letter, Legal, B5 (ISO), B5 (JIS), Executive, A5, B6 (ISO)	

*1 Up to 3 envelopes

*2 Up to 10 sheets



When printing transparencies, remove each one from the face-down output tray after it exits the DCP.

How to load paper

To load paper or other media in the paper tray

- 1 Pull the paper tray completely out of the DCP.

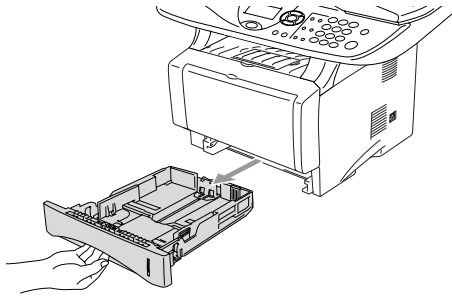

- 2 While pressing the paper guide release lever, slide the adjusters to fit the paper size.

Check that the guides are firmly in the slots.

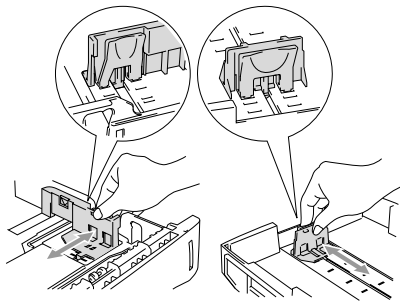

-  For Legal size paper, press the universal guide release button and pull out the back of the paper tray.

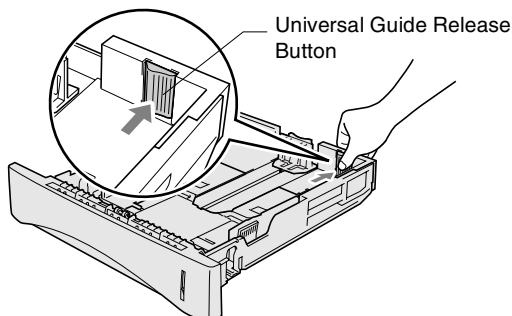

3 Fan the stack of paper well to avoid paper jams and misfeeds.

4 Put paper in the paper tray.

Check that the paper is flat in the tray, below the maximum paper mark, and that the paper guide is flush against the paper stack.

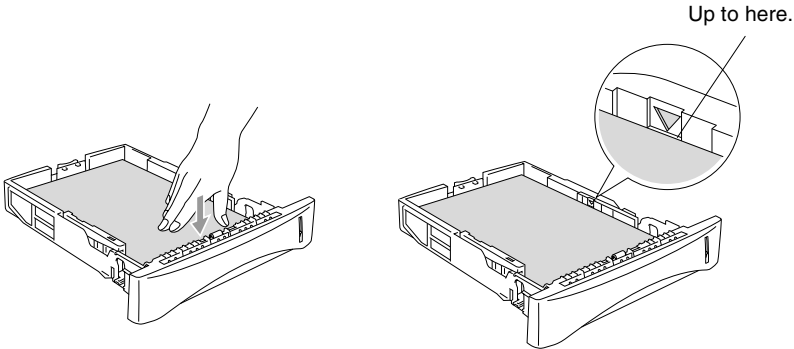

5 Put the paper tray firmly back in the DCP and unfold the support flap before you use the DCP.

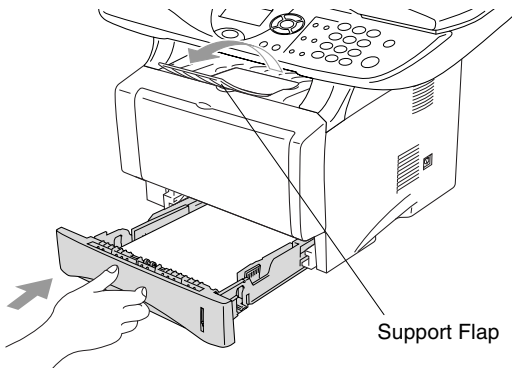

When you put paper in the paper tray, please remember the following:

- The side to be printed on must be face down.
- Put the leading edge (top of the paper) in first and push it gently into the tray.
- To copy Legal size paper, unfold the secondary support flap, too.

To load paper or other media in the manual feed tray (For DCP-8040)

 When printing envelopes and labels you should only use the manual feed tray.

- 1** Open the manual feed tray. Slide the paper guides to fit the paper size.

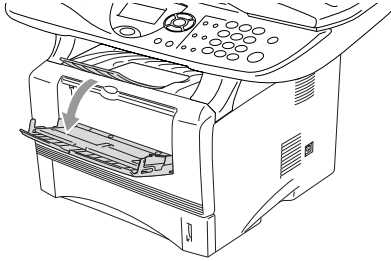

- 2** Using both hands put paper in the manual feed tray until the front edge of the paper touches the paper feed roller. Hold the paper in this position until the DCP automatically feeds the paper in for a short distance, and then let go of the paper.

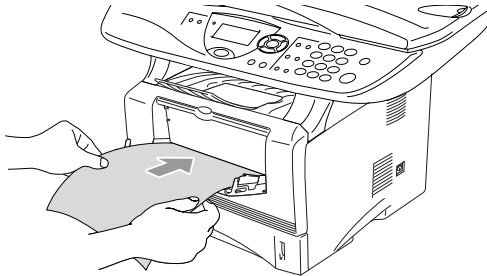



When you put paper in the manual feed, please remember the following:

- The side to be printed on must be face up.
- Put the leading edge (top of the paper) in first and push it gently into the tray.
- Make sure that the paper is straight and in the proper position on the manual feed tray. If it is not, the paper may not be fed properly, resulting in a skewed printout or a paper jam.
- Do not put more than one sheet of paper or envelope in the manual feed tray at any one time, or it may cause a jam.

To load paper or other media in the multi-purpose tray (MP tray) (For DCP-8045D)

 When printing envelopes and labels you should only use the multi-purpose tray.

- 1** Open the MP tray and lower it gently.

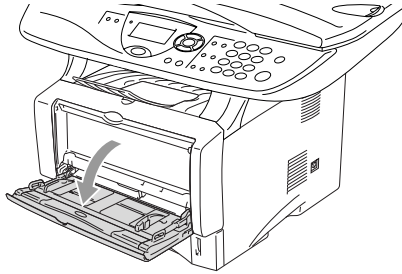

- 2** Pull out and unfold the MP tray support flap.

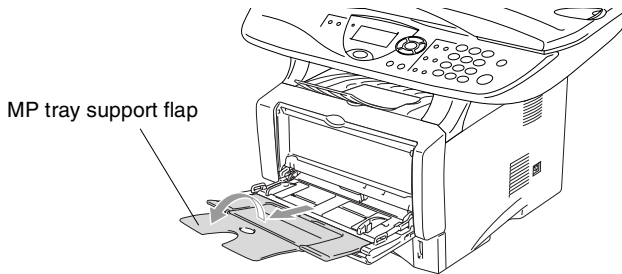

- 3** When loading paper in the MP tray, make sure it touches the back of the tray.

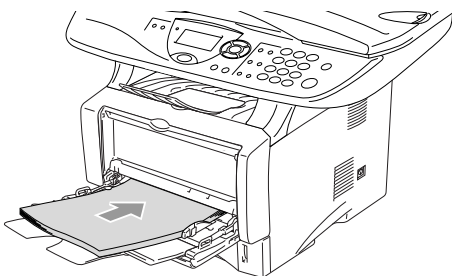

-  ■ Make sure that the paper is straight and in the proper position on the MP tray. If it is not, the paper may not be fed properly, resulting in a skewed printout or a paper jam.
 - You can place up to 3 envelopes or up to 50 sheets of 80 g/m² paper in the MP tray.
- 4** While pressing the paper-guide release lever, slide the paper guide to fit the paper size.

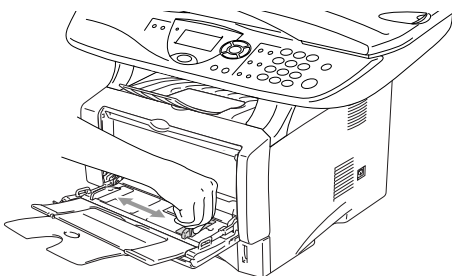

-  When you put paper in the MP tray, please remember the following:
 - The side to be printed on must be face up.
 - During printing, the inside tray rises to feed paper into the DCP.
 - Put the leading edge (top of the paper) in first and push it gently into the tray.

To use Automatic Duplexing for copy and print operations (For DCP-8045D)

If you want to print on both sides of the paper using the Duplex feature for copy or print, you will need to set the Paper Adjustment Lever to the size of paper you are using.

This feature is available for A4, Letter or Legal size paper. (See *Duplex/N in 1* on page 5-12 and *Two-sided printing (Duplex Printing)* in Software User's Guide on the CD-ROM.)

- 1** Load paper in the Paper Tray or Multi-purpose Tray.
- 2** Set the Paper Adjustment Lever for Duplex Printing, in the back of the DCP, to match your paper size.

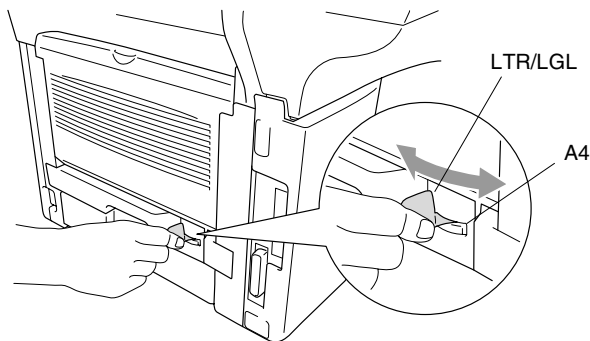

- 3** Your DCP is now ready to print two-sided pages.

3 On-screen programming



User-friendly programming

Your DCP is designed to be easy to use with LCD on-screen programming using the navigation keys. User-friendly programming helps you take full advantage of all the menu selections your DCP has to offer.

Since your programming is done on the LCD, we have created step-by-step on-screen instructions to help you program your DCP. All you need to do is follow the instructions as they guide you through the menu selections and programming options.

Menu table

You can probably program your DCP without the User's Guide. But to help you understand the menu selections and options that are found in the DCP programs, use the Menu table on page 3-4.

You can program your DCP by pressing **Menu** followed by the menu number. For example: to set `Quality` to `Photo`, press **Menu, 2, 1** and  or  to select `Photo`, and then press **Set**.

Navigation keys

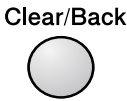
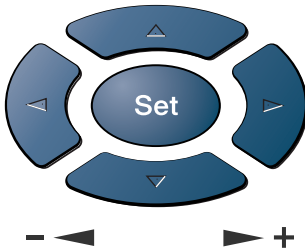

- * Access the menu
- * Go to the next menu level
- * Accept an option
- * Exit the menu by pressing repeatedly
- * Go back to the previous menu level
- * Scroll through the current menu level
- * Go back to the previous menu level
- * Go forward to the next menu level
- * Exit the menu

You can access the menu mode by pressing **Menu**.

When you enter the menu, the LCD scrolls.

Press **1** for General Setup menu

—OR—

Press **2** for Copy menu

—OR—



Press **3** for Printer menu

—OR—

Press **4** for LAN menu

(Only if the optional LAN board (NC-9100h) is installed.)



—OR—

You can scroll more quickly through each menu level by pressing the arrow for the direction you want:  or .

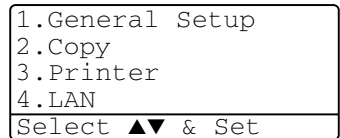
Then set an option by pressing **Set** when that option appears on the LCD.



The LCD will then show the next menu level.

Press  or  to scroll to your next menu selection.

Press **Set**.

When you finish setting an option, the LCD shows *Accepted*.



Use  to scroll backward if you passed your choices or want to save keystrokes.

The current setting is always the option with “*”.

Press the Menu numbers.
(ex. Press 1, 1 for Paper Type)

—OR—

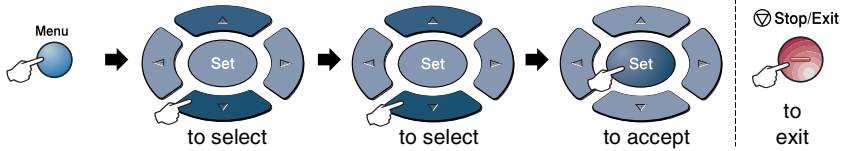

Main Menu	Submenu	Menu Selections	Options	Descriptions	Page
1.General Setup	1.Paper Type	1.MP Tray (DCP-8045D)	Thin Plain* Thick Thicker Transparency	Sets the type of paper in the Multi-purpose tray.	4-1
		2.Tray #1 (This menu only appears if you have the optional tray #2.)	Thin Plain* Thick Thicker Transparency	Sets the type of paper in paper tray #1.	4-1
		3.Tray #2 (option)	Thin Plain* Thick Thicker Transparency	Sets the type of paper in paper tray #2.	4-1
	2.Paper Size	1.Tray #1 (This menu only appears if you have the optional tray #2.)	A4* Letter Legal Executive A5 A6 B5 B6	Sets the size of paper in paper tray #1.	4-3
		2.Tray #2 (option)	A4* Letter Legal Executive A5 B5 B6	Sets the size of paper in paper tray #2.	4-3

 The factory settings are shown in Bold with *.

Press the Menu numbers.
(ex. Press 1, 1 for Paper Type)

—OR—

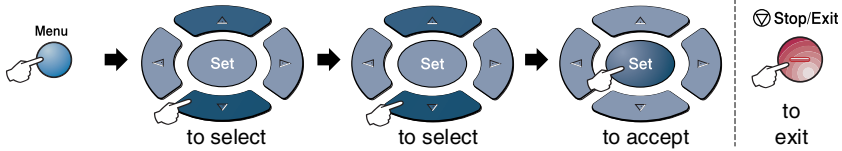

Main Menu	Submenu	Menu Selections	Options	Descriptions	Page
1.General Setup (Continued)	3.Beeper	—	Low Med * High Off	Adjusts the volume level of the beeper.	4-4
	4.Ecology	1.Toner Save	On Off *	Increases the life of the toner cartridge.	4-4
		2.Sleep Time	(00-99) 05Min *	Conserves power.	4-5
		3.Power Save	On Off *	Power Save Mode.	4-6
	5.Tray Use: Copy (For DCP-8040, this menu does not appear.) (If you have the optional tray #2, see page 3-10.)	—	Tray#1 Only MP Only Auto *	Selects the tray that will be used for Copy mode.	4-7
	5.LCD Contrast (For DCP-8040) 6.LCD Contrast (For DCP-8045D) (If you have the optional tray #2, see page 3-10.)	—	- □□□■ + - □□□□ + - □□■□ +* - □■□□ + - ■□□□ +	Adjusts the contrast of the LCD.	4-8
6.Drum Life (For DCP-8040) 7.Drum Life (For DCP-8045D) (If you have the optional tray #2, see page 3-10.)	—	—	You can check the percentage of drum life that remains available.	7-32	



The factory settings are shown in Bold with *.

Press the Menu numbers.
(ex. Press 1, 1 for Paper Type)

—OR—

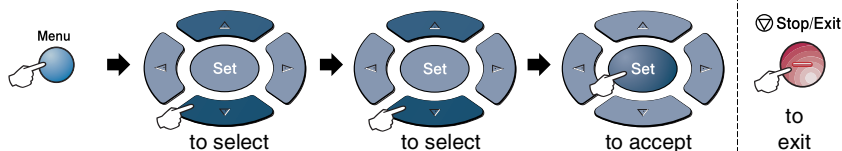

Main Menu	Submenu	Menu Selections	Options	Descriptions	Page
1.General Setup (Continued)	7. Page Counter (For DCP-8040)	—	Total Copy Print List	Lets you check the number of total pages the DCP has printed so far.	7-32
	8. Page Counter (For DCP-8045D) (If you have the optional tray #2, see page 3-10.)	—	—	—	—
	8. System Setup (For DCP-8040)	—	—	You can print lists.	4-8
	9. System Setup (For DCP-8045D) (If you have the optional tray #2, see page 3-10.)	—	—	—	—
0. Local Language (For Czech and Hungarian)	—	—	Czech Hungarian English *	Allows you to change the LCD Language for your country.	See Quick Setup Guide
0. Local Language (For Norwegian, Swedish, Danish and Finnish)	—	—	Norwegian Swedish Danish Finnish English	Allows you to change the LCD Language for your country.	



- The factory settings are shown in **Bold** with *.
- The 0.Local Language menu is not available on UK machine.

Press the Menu numbers.
(ex. Press 1, 1 for Paper Type)

—OR—

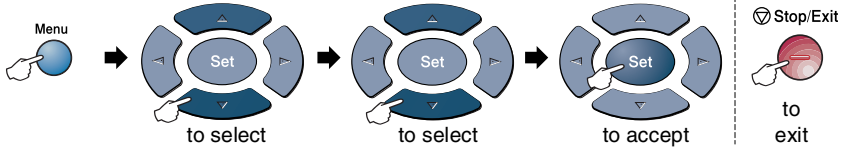

Main Menu	Submenu	Menu Selections	Options	Descriptions	Page
2.Copy	1.Quality		Text Photo Auto *	Selects the Copy resolution for your type of original.	5-9
	2.Contrast	—	- o o o o + - o o o o + - o o o o + * - o o o o + - ■ o o o o +	Adjusts the contrast for copies.	5-10
3.Printer	1.Emulation	—	Auto * HP LaserJet BR-Script 3	Selects the Emulation mode.	See Software User's Guide on the CD-ROM
	2.Print Options	1.Internal Font	—	Prints a list of the DCP's internal fonts or current printer settings.	
		2.Configuration	—		
3.Reset Printer	—	—	—	Returns the DCP to the factory default settings.	

 The factory settings are shown in Bold with *.

Press the Menu numbers.
(ex. Press 1, 1 for Paper Type)

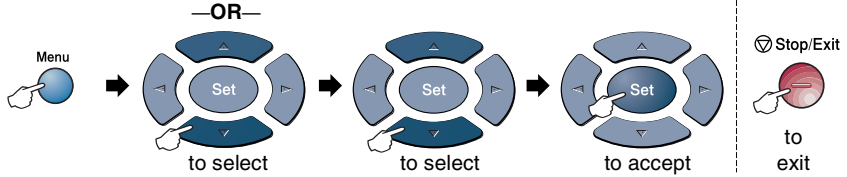

 If you installed optional LAN board (NC-9100h), the LCD shows the following LAN menu. (See the Network User's Guide on the CD-ROM.)

Main Menu	Submenu	Menu Selections	Options	Descriptions	Page
4.LAN (option)	1.Setup TCP/IP	1.BOOT Method	Auto* Static RARP BOOTP DHCP	You can choose the BOOT method that best suits you needs.	See Network User's Guide on the CD-ROM.
		2.IP Address	[000-255]. [000-255]. [000-255]. [000-255]	Enter the IP address.	
		3.Subnet Mask	[000-255]. [000-255]. [000-255]. [000-255]	Enter the Subnet mask.	
		4.Gateway	[000-255]. [000-255]. [000-255]. [000-255]	Enter the Gateway address.	
		5.Host Name	BRN_XXXXXX	Enter the Host name.	
		6.WINS Config	Auto* Static	You can choose the WINS configuration mode.	
		7.WINS Server	Primary Secondary	Specifies the IP address of the primary or secondary server.	
		8.DNS Server	Primary Secondary	Specifies the IP address of the primary or secondary server.	

 The factory settings are shown in Bold with *.

Press the Menu numbers.
(ex. Press 1, 1 for Paper Type)

—OR—

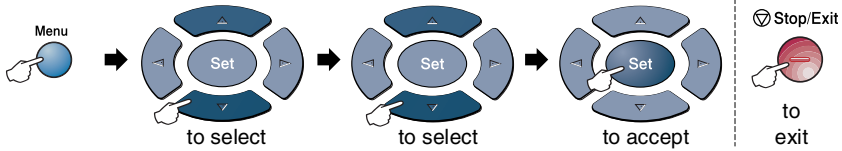

(See the Network User's Guide on the CD-ROM.)

Main Menu	Submenu	Menu Selections	Options	Descriptions	Page
4.LAN (option) (Continued)	1.Setup TCP/IP (Continued)	9.APIPA	On * Off	Automatically allocates the IP address from the link-local address range.	See Network User's Guide on the CD-ROM.
	2.Setup Misc.	1.Netware	On * Off	Select On to use the DCP on a Netware network.	
		2.Net Frame	Auto * 8023 ENET 8022 SNAP	Lets you specify the frame type.	
		3.AppleTalk	On * Off	Select On to use the DCP on a Macintosh network.	
		4.DLC/LLC	On * Off	Select On to use the DCP on a DLC/LLC network.	
		5.Net BIOS/IP	On * Off	Select On to use the DCP on a Net BIOS/IP network.	
		6.Ethernet	Auto * 100B-FD 100B-HD 10B-FD 10B-HD	Selects Ethernet link mode.	

 The factory settings are shown in Bold with *.



If you have the optional paper tray, the LCD displays these menu options.

(For DCP-8040 with the optional paper tray #2)

Main Menu	Submenu	Menu Selections	Options	Descriptions	Page
1.General Setup	5.Tray Use: Copy	—	Tray#1 Only Tray#2 Only Auto*	Select the tray that will be used for copying.	4-7
	6.LCD Contrast	—	- 0000 ■ + - 000 ■ 0 + - 00000 +* - 00000 + - ■0000 +	Adjusts the contrast of the LCD.	4-8
	7.Drum Life	—	—	You can check the percentage of drum life that remains available.	7-32
	8.Page Counter	—	Total Copy Print List	Lets you check the number of total pages the DCP has printed so far.	7-32
	9.System Setup	—	—	You can print lists.	4-8

(For DCP-8045D with the optional paper tray #2)

Main Menu	Submenu	Menu Selections	Options	Descriptions	Page
1.General Setup	5.Tray Use: Copy	—	Tray#1 Only Tray#2 Only MP Only Auto*	Select the tray that will be used for copying.	4-7
	6.LCD Contrast	—	- 0000 ■ + - 000 ■ 0 + - 00000 +* - 00000 + - ■0000 +	Adjusts the contrast of the LCD.	4-8
	7.Drum Life	—	—	You can check the percentage of drum life that remains available.	7-32
	8.Page Counter	—	Total Copy Print List	Lets you check the number of total pages the DCP has printed so far.	7-32
	9.System Setup	—	—	You can print lists.	4-8



The factory settings are shown in Bold with *.

Key Operations table

You can use the keys on the control panel to conveniently choose *temporary* copy settings and access the scanning operations. The Key Operations Table below will help you understand the options they provide.

Temporary keys	Options	Descriptions	Page
Secure	–	Print data saved in the memory by entering your four-digit password.	See Software User's Guide on the CD-ROM
Job Cancel	–	Clear data from the printer memory.	
Scan	Scan to E-mail	Scan a black & white or color original into your E-mail application as a file attachment.	
	Scan to Image	Scan an image into your graphics application (such as a color picture) for viewing and editing.	
	Scan to OCR	Scan a text document so ScanSoft® will perform OCR in OmniPage® to convert it to editable text and display it in your word processing application.	
	Scan to File	Scan a black & white or a color original into your computer and save it as a file in the folder you choose.	
Enlarge/Reduce	104%, 141%, 200%, AUTO, Custom, 50%, 70%, 78%, 83%, 85%, 91% (Full Page), 94%, 97%	Enlarge or reduce the size of copies.	5-7
Contrast	- □□■□□ +	Adjust the contrast.	5-10
Quality	Auto, Text, Photo	Select the Copy resolution for your type of original.	5-9
Tray Select (For DCP-8040)	#1 (XXX*), #2 (XXX*), Auto	Change the tray use only for the next copy.	5-11
(For DCP-8045D)	#1 (XXX*), #2 (XXX*), MP Tray, Auto		5-11
Sort		Sort multiple copies, using the ADF.	5-9
N in 1 (For DCP-8040)	2 in 1 (P), 2 in 1 (L), 4 in 1 (P), 4 in 1 (L), Poster, off	Change the layout of copies on the print media.	5-14
Duplex/N in 1 (For DCP-8045D)	Portrait 1, Portrait 2, Landscape 1, Landscape 2		5-12

■ (XXX*) is the paper size you set.

■ #2 (XXX*) is shown when the optional paper tray is installed.

4 Getting started

General Setup

Setting the Paper Type



To get the best print quality, set the DCP for the type of paper you are using.

For DCP-8040

1 Press **Menu, 1, 1**.

—OR—

If you have the optional paper tray, press **Menu, 1, 1, 1** to set the paper type for Tray #1 or **Menu, 1, 1, 2** to set the paper type for Tray #2.

2 Press  or  to select **Thin**, **Plain**, **Thick**, **Thicker** or **Transparency**.

3 Press **Set**.

4 Press **Stop/Exit**.

11.Paper Type
▲ Plain
Thick
▼ Thicker
Select ▲▼ & Set

11.Paper Type
1.Tray #1
2.Tray #2
Select ▲▼ & Set

For DCP-8045D



- 1 Press **Menu, 1, 1, 1** to set the paper type for MP Tray.

—OR—

Press **Menu, 1, 1, 2** to set the paper type for Tray #1.

—OR—

If you have the optional paper tray, press **Menu, 1, 1, 3** to set the paper type for Tray #2.

- 2 Press  or  to select Thin, Plain, Thick, Thicker or Transparency.

- 3 Press **Set**.

- 4 Press **Stop/Exit**.

11.Paper Type
1.MP Tray
2.Tray #1
3.Tray #2
Select ▲▼ & Set

11.Paper Type
1.MP Tray
▲ Plain
▼ Thick
Select ▲▼ & Set





You can select Transparency for Tray #1 and Tray #2 only when A4, Letter or Legal is selected in **Menu, 1, 2**.

Setting the Paper Size

You can use eight sizes of paper for printing copies: A4, letter, legal, executive, A5, A6, B5 and B6. When you change the size of paper in the DCP, you will need to change the setting for Paper Size at the same time so your DCP can fit reduced copy on the page.

1 Press **Menu, 1, 2**.

2 Press  or  to select A4, Letter, Legal, Executive, A5, A6, B5 or B6.

Press **Set**.

3 Press **Stop/Exit**.

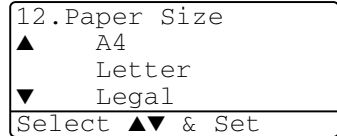



With optional paper tray (LT-5000)

1 Press **Menu, 1, 2, 1** to set the paper size for Tray #1.

—OR—

Press **Menu, 1, 2, 2** to set the paper size for Tray #2.

2 Press  or  to select A4, Letter, Legal, Executive, A5, A6, B5 and B6.

Press **Set**.

3 Press **Stop/Exit**.





■ If you are using the optional paper tray, paper size A6 is not available.

■ If you select Transparency in **Menu, 1, 1**, you can only select A4, Letter or Legal.

Setting the Beeper Volume



You can change the beeper volume. The default setting is **Med**. When the beeper is on, the DCP beeps every time you press a key or make a mistake.

- 1 Press **Menu, 1, 3**.
- 2 Press  or  to select your option.
(Low, Med, High or Off)
Press **Set**.
- 3 Press **Stop/Exit**.

13.Beeper
▲ Med
High
▼ Off
Select ▲▼ & Set

Toner Save

You can conserve toner using this feature. When you set Toner Save to **On**, print appears somewhat lighter. The default setting is **Off**.

- 1 Press **Menu, 1, 4, 1**.
- 2 Press  or  to select **On** (or **Off**).
- 3 Press **Set**.
- 4 Press **Stop/Exit**.

14.Ecology
1.Toner Save
▲ On
▼ Off
Select ▲▼ & Set

Sleep Time



Setting the Sleep Time reduces power consumption by turning off the fuser inside the DCP, while it is idle. You can choose how long the DCP is idle (from 00 to 99 minutes) before it goes into sleep mode. The timer is automatically reset when the DCP receives PC data, or makes a copy. The factory setting is 05 minutes. While the DCP is in sleep mode, you will see **Sleep** on the LCD. If you try to print or copy in sleep mode, there will be a short delay while the fuser warms up to working temperature.

- 1** Press **Menu, 1, 4, 2**.
- 2** Use the numeric keys to enter the length of time the DCP is idle before it goes into sleep mode (00 to 99).
- 3** Press **Set**.
- 4** Press **Stop/Exit**.



- If you want to turn sleep mode off, press **Secure** and **Job Cancel** simultaneously in Step 2.
- If the DCP is in Sleep Mode when you change the Sleep Time, the new setting will take effect the next time the DCP copies or prints is restarted.

Turning off the Scanner Lamp

The scanner lamp stays on for 16 hours before automatically switching off to preserve the life of the lamp. You can turn off the scanner lamp manually if you wish by pressing the  and  keys simultaneously. The scanner lamp will remain turned off until the next time you use the scanning feature.



Turning off the scanner lamp will also reduce the power consumption.



- Please note that turning the lamp off regularly will reduce the lamp's life. Some people prefer to turn the lamp off as they leave the office, or late at night at home. This is not necessary for normal day to day use.

Power Save

Setting Power Save mode reduces power consumption. If Power Save Mode is switched On, when the DCP is idle and the scanner lamp is turned off, it drops into power save mode in approx. 10 minutes automatically.

- 1 Press **Menu**, **1**, **4**, **3**.
- 2 Press  or  to select On (or Off).
- 3 Press **Set** when the screen displays your selection.
- 4 Press **Stop/Exit**.

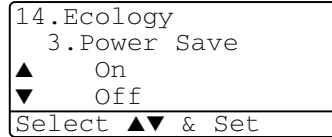



Setting the Tray Use for Copy mode



If your DCP is a DCP-8040 without the optional tray #2, you can skip this setting.

DCP-8040



The default setting of **Auto** allows *¹your DCP to choose the optional Tray #2 when paper is out in Tray #1 or *²when the size of the document will fit best on the paper in Tray #2.

- 1 Press **Menu, 1, 5**.
- 2 Press  or  to select Tray#1 Only, Tray#2 Only, or Auto.
- 3 Press **Set**.
- 4 Press **Stop/Exit**.

15.Tray Use: Copy
▲ Tray#1 Only
Tray#2 Only
▼ Auto
Select ▲▼ & Set



DCP-8045D

The default setting of **Auto** allows *¹your DCP to choose the optional Tray #2 or the MP tray when paper is out in Tray #1 and *²when the size of the document will fit best on the paper in Tray #2.

- 1 Press **Menu, 1, 5**.
- 2 Press  or  to select Tray#1 Only, MP Only, or Auto.

—OR—

If you have the optional paper tray.

Press  or  to select Tray#1 Only, Tray#2 Only, MP Only, or Auto.

- 3 Press **Set**.
- 4 Press **Stop/Exit**.

15.Tray Use: Copy
▲ Tray#1 Only
MP Only
▼ Auto
Select ▲▼ & Set

15.Tray Use: Copy
▲ Tray#1 Only
Tray#2 Only
▼ MP Only
Select ▲▼ & Set



*¹ Copies will automatically be printed from Tray #2 only if the Paper Size setting for Tray #2 is the same as Tray #1.

*² When using the ADF, copies will automatically be printed from Tray #2 if the Paper Size setting for Tray #2 is different than Tray #1 and this paper size is more suitable for the scanned original.

Setting the LCD Contrast

You can change the contrast to help the LCD look lighter or darker.

- 1 (DCP-8040) Press **Menu, 1, 5**.
(DCP-8045D) Press **Menu, 1, 6**.

—OR—

If you have the optional tray #2,
press **Menu, 1, 6**.

- 2 Press  to increase the contrast.

—OR—

Press  to decrease the contrast.

Press **Set**.

- 3 Press **Stop/Exit**.



Printing the System Setup List

You can print a list of various settings.

- 1 (DCP-8040) Press **Menu, 1, 8**.
(DCP-8045D) Press **Menu, 1, 9**.

—OR—

If you have the optional Tray #2, press **Menu, 1, 9**.

- 2 Press **Start**.

5 Making copies

Using the DCP as a copier

You can use your DCP as a copier, making up to 99 copies at a time.

Printable area

The printable area of your DCP begins at approximately 2 mm from both ends and 3 mm from the top or bottom of the paper.

Ex: A4 (Document) → A4 (Paper)

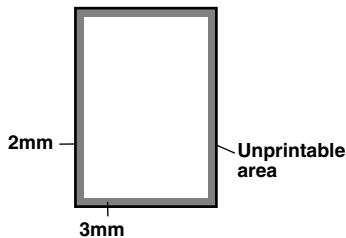

Temporary copy settings

You can improve your copies by using the Temporary Copy Keys: **Enlarge/Reduce**, **Contrast**, **Quality**, **Tray Select**, **Sort** and **N in 1** (For DCP-8040) or **Duplex/N in 1** (For DCP-8045D). These settings are *temporary*, and the DCP returns to its default settings 1 minute after it finishes copying. If you want to use these temporary settings again, place the next document in the ADF or on the scanner glass within that time.

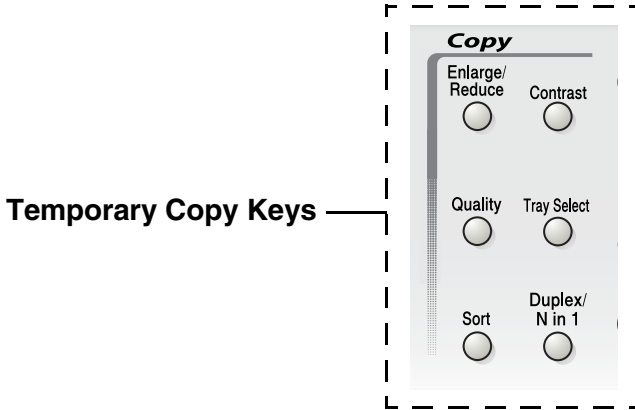

Making a single copy from the ADF

- 1 Place the document face up in the ADF.
 - 2 Press **Start**.
Do **NOT** pull on the document while copying is in progress.
-  To stop copying and eject the document, press **Stop/Exit**.

Making multiple copies from the ADF

- 1 Insert the document face up in the ADF.
 - 2 Use the numeric keys to enter the number of copies you want (up to 99).
 - 3 Press **Start**.
-  To sort the copies, press the **Sort** key.

Single or multiple copies using the scanner glass

You can make multiple copies using the scanner glass. Multiple copies will be stacked (all copies of page 1, then all copies of page 2, and so on). Use the Temporary Copy keys to choose more settings. (See *Using the Copy keys (Temporary settings)* on page 5-6.)

1 Lift the Document Cover.

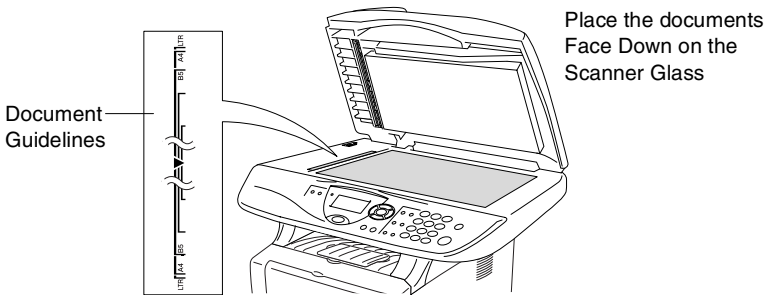

2 Using the document guidelines on the left, center the document face down on the scanner glass and close the document cover.

3 Using the numeric keys, enter the number of copies you want (up to 99).

For example, press **3 8** for 38 copies.

4 Press **Start**.

The DCP will start scanning the document.



If you want to sort multiple copies, use the ADF.

(See *Making a single copy from the ADF* on page 5-3.)

Out of Memory message

If the Out of Memory message appears, press **Stop/Exit** to cancel or press **Start** to copy scanned pages. You will need to clear some jobs from the memory before you can continue.

Out of Memory
Copy: Press Start
Quit: Press Stop



Then if this error message appears more than once you may wish to consider increasing the memory size. For more information on how to increase the memory size, see *Memory board* on page 8-1.

Using the Copy keys (Temporary settings)

When you want to change the settings only for the next copy, use the Temporary Copy keys.

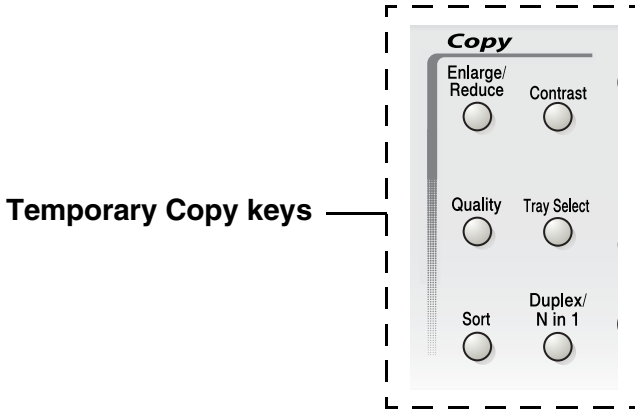

You can use different combinations. The large LCD shows your current Copy mode settings.

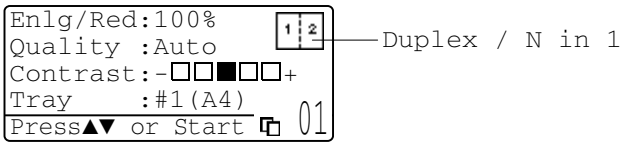

Example of Copy mode LCD

Enlarge/Reduce

You can select the following enlargement or reduction ratios.

Auto sets the DCP to calculate the reduction ratio that fits the size of your paper.

Custom allows you to enter a ratio from 25% to 400%.



Press Enlarge/Reduce	
	100%
	104% (EXE → LTR)
	141% (A5 → A4)
	200%
	Auto
	Custom (25 - 400%)
	50%
	70% (A4 → A5)
	78% (LGL → LTR)
	83% (LGL → A4)
	85% (LTR → EXE)
	91% (Full Page)
	94% (A4 → LTR)
	97% (LTR → A4)



Auto appears only when you place the document in the ADF.

- 1** Place the document face up in the ADF, or face down on the scanner glass.
- 2** Use the numeric keys to enter the number of copies you want (up to 99).
- 3** Press **Enlarge/Reduce**.
- 4** Press **Enlarge/Reduce** or .

Enlg/Red:100%	
Quality :Auto	
Contrast:-□□■□□+	
Tray :#1(A4)	01

5 Press  or  to select the enlargement or reduction ratio you want.

Press **Set**.

—OR—

You can select **Custom** (25–400%) and press **Set**.

Use the dial pad to enter an enlargement or reduction ratio from 25% to 400%.

Press **Set**.

(For example, press **5 3** to enter 53%.)

6 Press **Start**.

—OR—

Press other temporary copy keys for more settings.





■ Special Copy Options (2in1, 4in1 or Poster) are not available with **Enlarge/Reduce**.

■ **Auto** is not available with the scanner glass.

Quality (type of document)

You can select the Quality for your type of document. The default setting is `Auto`, which is used for documents that contain both text and photographs. `Text` is used for documents containing only text. `Photo` is used for copying photographs.

- 1** Place the document face up in the ADF, or face down on the scanner glass.
- 2** Use the numeric keys to enter the number of copies you want (up to 99).
- 3** Press **Quality**.
- 4** Press  or  to choose the type of document (`Auto`, `Text` or `Photo`).
Press **Set**.
- 5** Press **Start**.

—OR—

Press other Temporary Copy keys for more settings.

Sorting copies using the ADF

If you want to sort multiple copies, use the ADF. Pages will be printed in the order 123, 123, 123, and so on.



- 1** Place the document face up in the ADF.
- 2** Use the numeric keys to enter the number of copies you want (up to 99).
- 3** Press **Sort**.
- 4** Press **Start**.

—OR—

Press other Temporary Copy keys for more settings.

Contrast



You can adjust copy contrast to make copies darker or lighter.

- 1 Place the document face up in the ADF, or face down on the scanner glass.
- 2 Use the numeric keys to enter the number of copies you want (up to 99).
- 3 Press **Contrast**.
- 4 Press  to make a copy lighter.
—OR—
Press  to make a copy darker.
Press **Set**.
- 5 Press **Start**.
—OR—
Press other Temporary Copy keys for more settings.

<p>Press Contrast</p> <p>Contrast</p> 	- <input type="checkbox"/> <input type="checkbox"/> <input checked="" type="checkbox"/> <input type="checkbox"/> <input type="checkbox"/> +
	- <input type="checkbox"/> <input type="checkbox"/> <input type="checkbox"/> <input checked="" type="checkbox"/> <input type="checkbox"/> +
	- <input type="checkbox"/> <input type="checkbox"/> <input type="checkbox"/> <input type="checkbox"/> <input checked="" type="checkbox"/> +
	- <input checked="" type="checkbox"/> <input type="checkbox"/> <input type="checkbox"/> <input type="checkbox"/> <input type="checkbox"/> +
	- <input type="checkbox"/> <input checked="" type="checkbox"/> <input type="checkbox"/> <input type="checkbox"/> <input type="checkbox"/> +
	- <input type="checkbox"/> <input type="checkbox"/> <input checked="" type="checkbox"/> <input type="checkbox"/> <input type="checkbox"/> +
	- <input type="checkbox"/> <input type="checkbox"/> <input type="checkbox"/> <input checked="" type="checkbox"/> <input type="checkbox"/> +

Tray Select

You can change the tray use only for the next copy.

- 1** Place the document face up in the ADF, or face down on the scanner glass.
- 2** Use the numeric keys to enter the number of copies you want (up to 99).
- 3** Press **Tray Select**.
- 4** Press  or  to select the tray usage.
Press **Set**.
- 5** Press **Start**.

—OR—

Press other Temporary Copy keys for more settings.

(For DCP-8040 with the optional paper tray #2)

Press Tray Select Tray Select 	Auto
	#1 (XXX) *
	#2 (XXX) *

(For DCP-8045D with the optional paper tray #2)

















Press Tray Select Tray Select 	Auto
	#1 (XXX) *
	#2 (XXX) *
	MP Tray



* XXX is the paper size you set in **Menu, 1, 2**.

 For DCP-8040 the LCD displays the tray use selections only if the optional paper tray is installed.

Duplex/N in 1

'Duplex' prints on both sides of the paper.

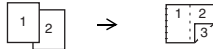
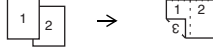
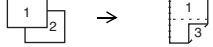
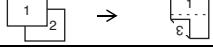
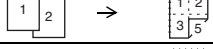
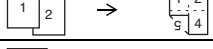
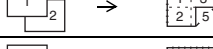
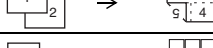
Temporary key	Level 1	Level 2	Option	document → Finished Layout	
Press Duplex/N in 1 (DCP-8045D) N in 1 (DCP-8040) Duplex/ N in 1 	N in 1	—	2 in 1 (P)	 → 	
			2 in 1 (L)	 → 	
			4 in 1 (P)	 → 	
			4 in 1 (L)	 → 	
	Duplex(1 in 1) (DCP-8045D)	Portrait1	—		 → 
				Portrait2	Single Sided
		Landscape1	—	Single Sided	 → 
				Double Sided	 → 
		Landscape2	—		 → 



Temporary key	Level 1	Level 2	Option	document → Finished Layout
Press Duplex/N in 1 (DCP-8045D) N in 1 (DCP-8040) Duplex/ N in 1 	Duplex(2 in 1) (DCP-8045D)	—	Portrait1	
			Portrait2	
			Landscape1	
			Landscape2	
	Duplex(4 in 1) (DCP-8045D)	—	Portrait1	
			Portrait2	
			Landscape1	
			Landscape2	
	Poster	—		
	Off	—	—	—

Duplex/N in 1 copy

N in 1 copy

You can save paper by copying either two or four pages onto one page. Please make sure paper size is set to A4, Letter or Legal.

- 1 Place the document face up in the ADF, or face down on the scanner glass.
- 2 Use the numeric keys to enter the number of copies you want (up to 99).
- 3 Press **Duplex/N in 1**.
Press **Set** to select N in 1.

- 4 Press  or  to select 2 in 1 (P), 2 in 1 (L), 4 in 1 (P) or 4 in 1 (L).



Press **Set**.

- 5 If you are ready to copy, go to Step 7.

—OR—

Press  or  to select Quality, Contrast or Tray.

Press **Set**.

- 6 Press  or  to select a new setting.

Press **Set**.

- 7 Press **Start**.

If you are using the ADF, the DCP scans the originals and prints the copies.

—OR—

If you are using the scanner glass, the DCP scans the page. Place the next original on the scanner glass.

Enlg/Red:100%
Quality :Auto
Contrast:-□□■□□+
Tray :#1(A4)
Press ▲▼ or Start 01

8 Select **1** and press **Set**, or press **1**, to copy next page.

9 Repeat Steps 7 and 8 for each page of the layout.

10 After all the pages of the document have been scanned, select **2** and press **Set**, or press **2**, to print.

Flatbed Copy: Next Page? 1.Yes 2.No Select▲▼ & Set
--





- (P) means Portrait and (L) means Landscape.
- You can also combine the N in 1 and Duplex operations. (See *Duplex (2 in 1) and Duplex (4 in 1) (For DCP-8045D)* on page 5-19.)
- For 2 in 1 (P), 2 in 1 (L), 4 in 1 (P) or 4 in 1 (L), you can not use the **Enlarge/Reduce** setting.

Poster

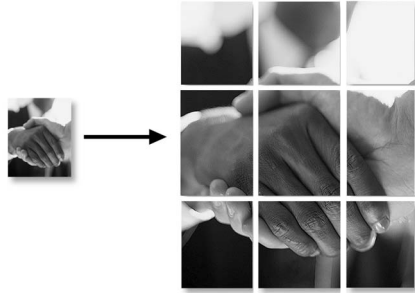
You can make a poster size copy of a photograph. You must use the scanner glass.



- 1 Place the document face down on the scanner glass.
- 2 Press **Duplex/N in 1** and  or  to select **Poster**. Press **Set**.

- 3 Press **Start**.

The DCP starts scans the original and prints the pages for the poster.









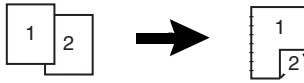

For poster copies, you cannot make more than one copy or use the Enlarge/Reduce setting.

Duplex (1 in 1) (For DCP-8045D)







Make a double-sided copy from a single-sided document

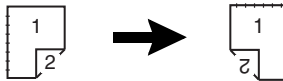





- 1** Place the document face up in the ADF, or face down the scanner glass.
- 2** Use the numeric keys to enter the number of copies you want (up to 99).
- 3** Press **Duplex/N in 1** and  or  to select Duplex(1 in 1).
Press **Set**.
- 4** Press  or  to select Portrait2 or Landscape1.
Press **Set**.
—OR—
Press  or  to select Portrait1 or Landscape2, and then go to Step 6.
- 5** Press  or  to select Single Sided for the document (If you are using the scanner glass or changed the number of copies at Step 2, this option will not appear).
Press **Set**.
- 6** Press **Start** to scan the document.
If you placed the document in the ADF, the DCP starts printing.
—OR—
If you placed the document on the scanner glass, go to Step 7.
- 7** Place the next document on the scanner glass.
Select **1** and press **Set** or press **1** to copy next page.
- 8** After all the pages of the document have been scanned, select **2** and press **Set** or press **2** to print.

Make a double-sided copy from a double-sided document



- 1** Place the document face up in the ADF.
- 2** Press **Duplex/N in 1** and  or  to select Duplex(1 in 1).
Press **Set**.
- 3** Press  or  to select Portrait2 or Landscape1.
Press **Set**.
- 4** Press  or  to select Double Sided for the document.
Press **Set**.
- 5** Press **Start**.
- 6** Make sure that you have put the documents in the ADF as shown on the LCD and press **Start**.
- 7** After all the pages of the document have been scanned on one side, turn the other side of the document face up in the ADF.
Press **Start**.

Duplex (2 in 1) and Duplex (4 in 1) (For DCP-8045D)



- 1** Place the document face up in the ADF, or face down on the scanner glass.
- 2** Use the numeric keys to enter the number of copies you want (up to 99).
- 3** Press **Duplex/N in 1** and  or  to select Duplex(2 in 1) or Duplex(4 in 1).
Press **Set**.
- 4** Press  or  to select Portrait1, Portrait2, Landscape1 or Landscape2.
Press **Set**.
- 5** Press **Start** to scan the document.
If you placed the document in the ADF, the DCP starts printing.
—OR—
If you placed the document on the scanner glass, go to Step 6.
- 6** Place the next document on the scanner glass.
Select **1** and press **Set** or press **1** to copy next page.
- 7** After all the pages of the document have been scanned, select **2** and press **Set** or press **2** to print.

Changing the default copy settings

You can adjust the copy settings that are shown in the chart. These settings will stay until you change them again.

Submenu	Menu Selections	Options	Factory Settings
1.Quality	—	Text	Auto
		Photo	
		Auto	
2.Contrast	—	- ◻◻◻◻ + - ◻◻◻◻ + - ◻◻◻◻ + - ◻◻◻◻ + - ◻◻◻◻ +	- ◻◻◻◻ +



Quality

- 1 Press **Menu**, **2**, **1**.
- 2 Press  or  to select **Text**, **Photo** or **Auto**.
Press **Set**.
- 3 Press **Stop/Exit**.

21.Quality
▲ Auto
Text
▼ Photo
Select ▲▼ & Set

Contrast

You can change the contrast to help an image look lighter or darker.

- 1 Press **Menu**, **2**, **2**.
- 2 Press  to make lighter.
—OR—
Press  to make darker.
Press **Set**.
- 3 Press **Stop/Exit**.

22.Contrast
- ◻◻◻◻ +
Select ◀▶ & Set

6

Important information

IEC 60825 Specification

This machine is a Class 1 laser product as defined in IEC 60825 specifications. The label shown below is attached in countries where required.

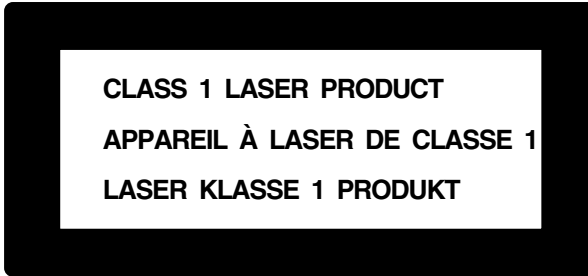

This machine has a Class 3B Laser Diode which emits invisible laser radiation in the Scanner Unit. The Scanner Unit should not be opened under any circumstances.

Laser Diode

Wave length: 760 - 810 nm

Output: 5 mW max.

Laser Class: Class 3B

Caution

Use of controls, adjustments or performance of procedures other than those specified in this manual may result in hazardous radiation exposure.

For your safety

To ensure safe operation the three-pin plug supplied must be inserted only into a standard three-pin power point which is effectively grounded through the normal household wiring.

The fact that the equipment operates satisfactorily does not imply that the power is grounded and that the installation is completely safe. For your safety, if in any doubt about the effective grounding of the power, consult a qualified electrician.

Disconnect device

This product must be installed near a socket outlet that is easily accessible. In case of emergencies, you must disconnect the power cord from the socket outlet in order to shut off power completely.

IT power system (For Norway only)

This product is also designed for IT power system with phase to phase voltage 230V.

LAN connection

Caution: Connect this product to the LAN connection which is not subjected to overvoltages.

International ENERGY STAR[®] Compliance Statement

The purpose of the International ENERGY STAR[®] Program is to promote the development and popularization of energy-efficient office equipment.

As an ENERGY STAR[®] Partner, Brother Industries, Ltd. has determined that this product meets the ENERGY STAR[®] guidelines for energy efficiency.



Ratio interference (220-240V Model Only)

This product complies with EN55022(CISPR Publication 22)/Class B. Before this product is used, ensure that you use the following interface cables.

- 1** A shielded parallel interface cable with twisted-pair conductors and that it is marked "IEEE 1284 compliant". The cable must not exceed 1.8 meters in length.
- 2** A USB cable. The cable must not exceed 2.0 meters in length.

Important safety instructions

- 1** Read all of these instructions.
- 2** Save them for later reference.
- 3** Follow all warnings and instructions marked on the product.
- 4** Before cleaning, turn off the DCP's power switch and unplug the power cord from the wall outlet. Do not use liquid or aerosol cleaners. Use a damp cloth for cleaning.
- 5** Do not use this product near water.
- 6** Do not place this product on an unstable cart, stand, or table. The product may fall, causing serious damage to the product.
- 7** Slots and openings in the cabinet and the back or bottom are provided for ventilation; to ensure reliable operation of the product and to protect it from overheating, these openings must not be blocked or covered. The openings should never be blocked by placing the product on a bed, sofa, rug, or other similar surface. This product should never be placed near or over a radiator or heater. This product should never be placed in a built-in installation unless proper ventilation is provided.
- 8** This product should be operated from the type of power source indicated on the label. If you are not sure of the type of power available, call your dealer or local power company.
Use only the power cord supplied with this DCP.
- 9** This product is equipped with a 3-wire grounded plug, a plug having a third (grounded) pin. This plug will only fit into a grounded power outlet. This is a safety feature. If you are unable to insert the plug into the outlet, call your electrician to replace your obsolete outlet. Do not defeat the purpose of the grounded plug.
- 10** Do not allow anything to rest on the power cord. Do not place this product where people can walk on the cord.
- 11** Wait until pages have exited the DCP before picking them up.

- 12** Unplug this product from the wall outlet and refer servicing to Authorized Service Personnel under the following conditions:
- When the power cord is damaged or frayed.
 - If liquid has been spilled into the product.
 - If the product has been exposed to rain or water.
 - If the product does not operate normally when the operating instructions are followed. Adjust only those controls that are covered by the operating instructions. Improper adjustment of other controls may result in damage and will often require extensive work by a qualified technician to restore the product to normal operation.
 - If the product has been dropped or the cabinet has been damaged.
 - If the product exhibits a distinct change in performance, indicating a need for service.
- 13** To protect your product against power surges, we recommend the use of a power protection device (Surge Protector).
- 14** To reduce the risk of fire, electric shock and injury to persons, note the following:
- Do not use this product near appliances that use water, a swimming pool or in a wet basement.
 - Use only the power cord indicated in this manual.

Trademarks

The Brother logo is a registered trademark of Brother Industries, Ltd.

Brother is a registered trademark of Brother Industries, Ltd.

Multi-Function Link is a registered trademark of Brother International Corporation.

© Copyright 2004 Brother Industries, Ltd. All rights reserved.

Windows, Microsoft and Windows NT are registered trademarks of Microsoft in the U.S. and other countries.

Macintosh, QuickDraw, iMac and iBook are trademarks or registered trademarks of Apple Computer, Inc.

Postscript and Postscript Level 3 are registered trademarks or trademarks of Adobe Systems Incorporated.

PaperPort and OmniPage are registered trademarks of ScanSoft, Inc.

Presto! PageManager is a registered trademark of NewSoft Technology Corporation.

Each company whose software title is mentioned in this manual has a Software License Agreement specific to its proprietary programs.

All other brand and product names mentioned in this User's Guide are registered trademarks of their respective companies.

7 Troubleshooting and routine maintenance

Troubleshooting

Error messages

As with any sophisticated office product, errors may occur. If this happens, your DCP identifies the problem and displays an error message. The most common error messages are shown below.

ERROR MESSAGES		
ERROR MESSAGE	CAUSE	ACTION
Change Drum Soon	The drum unit is near the end of its life.	Use the drum unit until you have a print quality problem; then replace the drum unit with a new one.
	The drum counter was not reset.	1. Open the front cover, and then press Clear/Back . 2. Press 1 to reset.
Check Original	The documents were not inserted or fed properly, or document scanned from ADF was longer than about 90cm.	See <i>Document jams</i> on page 7-4.
Check Paper Check Paper #1 Check Paper #2	The DCP is out of paper or paper is not properly loaded in the paper tray. —OR— The paper is jammed in the DCP.	Refill the paper in the paper tray or MP tray. —OR— Remove the paper and load it again. See <i>Paper jams</i> on page 7-5 and <i>Paper is jammed in the duplex tray (For DCP-8045D)</i> on page 7-9.
Check Paper MP	Paper in the MP tray runs out.	Reload paper. (See <i>To load paper or other media in the multi-purpose tray (MP tray) (For DCP-8045D)</i> on page 2-9.)
Check Paper Size	When you see this error, the paper in the paper tray does not match the paper size you set in Menu, 1, 2 .	Load the appropriate size paper or change the default setting. (See <i>Setting the Paper Type</i> on page 4-1).
Check Scan Lock	The scanner lock is locked.	Release the scanner lock lever, and then press Stop/Exit .

ERROR MESSAGES		
ERROR MESSAGE	CAUSE	ACTION
Cooling Down Wait for a while	The temperature of the drum unit or toner cartridge is too hot. The DCP will pause its current print job and go in to cooling down mode. During the cooling down mode, you will hear the cooling fan running while the display on the DCP shows Cooling Down, and Wait for a while.	You must wait 20 minutes for it to cool.
Cover Open Pls Close Cover	The front cover was not completely closed.	Close the front cover for the drum unit.
DX Lever Error	The paper adjustment lever for duplex printing is not correctly set for the paper size.	Set the duplex lever to the correct position. (See <i>To use Automatic Duplexing for copy and print operations (For DCP-8045D)</i> on page 2-11.)
Face Up Open	The face-up output tray is open.	Please close the face-up output tray.
Fuser Open	The fuser cover is open.	Please close the jam clear cover. (See <i>Paper jams</i> on page 7-5.)
Machine Error XX	DCP has a mechanical problem.	Call Brother or your dealer for service.
No DX Tray	You tried to make duplex printing with duplex cover open.	Install the duplex tray correctly. (See <i>Paper is jammed in the duplex tray (For DCP-8045D)</i> on page 7-9.)
Out of Memory	You can't store data in the memory.	<p>(Copy operation in process) Press Stop/Exit and wait until the other operations in process finish and then try again.</p> <p>—OR— Add an optional memory. (See <i>Memory board</i> on page 8-1.)</p> <p>(Printing operation in process) Reduce print resolution. (See <i>Print Quality</i> in Software User's Guide on the CD-ROM.)</p> <p>—OR— Clear the data in the memory. (See <i>Out of Memory message</i> on page 5-5.)</p> <p>—OR— Add an optional memory. (See <i>Memory board</i> on page 8-1.)</p>

ERROR MESSAGES		
ERROR MESSAGE	CAUSE	ACTION
Paper Jam	The paper is jammed in the DCP.	See <i>Paper jams</i> on page 7-5 and <i>Paper is jammed in the duplex tray (For DCP-8045D)</i> on page 7-9.
Pls Open Cover	A page, piece of paper or paper clip, etc. may be jammed inside the DCP.	Open the front cover. If you see any jammed paper or other item, gently pull it out, then close the front cover. If the error message remains, open and close the front cover again. If the DCP cannot reset itself and return to the date and time prompt, it will display <i>Machine Error XX</i> . Then contact your Brother dealer for service.
Toner Empty	Toner cartridge is not installed. —OR— Toner is used up and printing is not possible.	Reinstall the toner cartridge. —OR— Replace the toner cartridge with a new one. (See <i>Replacing the toner cartridge</i> on page 7-24.)
Toner Low	If the LCD shows <i>Toner Low</i> , you can still print, however the DCP is telling you that the toner will soon run out.	Order a new toner cartridge now.

Document jams

Based upon where the document is jammed, follow the appropriate set of instructions to remove it.

Document is jammed in the top of the ADF unit.

- 1 Take out any paper from the ADF that is not jammed.
- 2 Lift the ADF cover.
- 3 Pull the jammed document out to the right.
- 4 Close the ADF cover.
- 5 Press **Stop/Exit**.

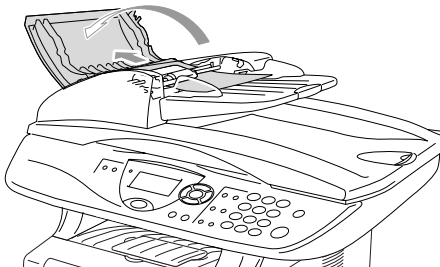

Document is jammed inside the ADF unit.

- 1 Take out any paper from the ADF that is not jammed.
- 2 Lift the document cover.
- 3 Pull the jammed document out to the right.
- 4 Close the document cover.
- 5 Press **Stop/Exit**.

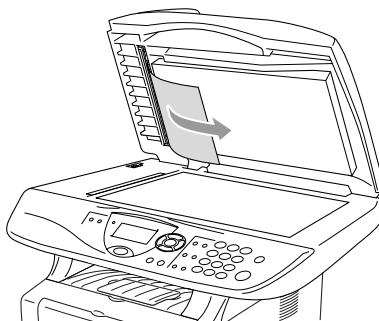

—OR—

- 1 Take the ADF support out of the ADF unit.
- 2 Pull the jammed document out to the right.
- 3 Press **Stop/Exit**.

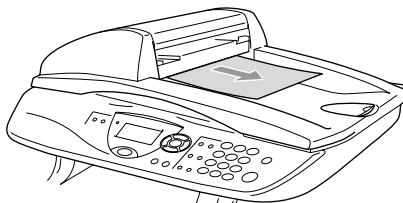

Paper jams

To clear paper jams, please follow the steps in this section.

WARNING

After you have just used the DCP, some parts inside the DCP are extremely hot. When you open the front cover or back output tray of the DCP, never touch the shaded parts shown in the following diagram.

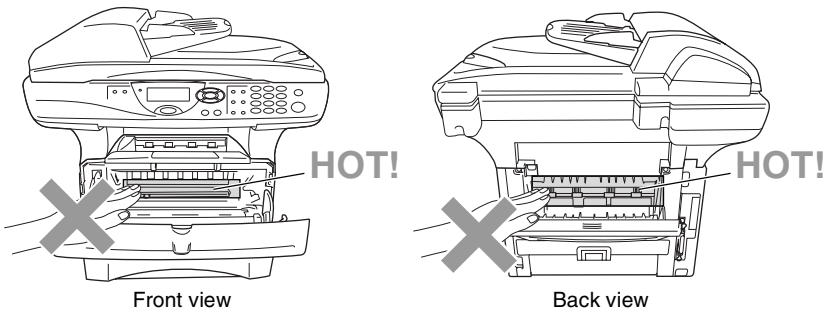

Clear the jammed paper as follows.

If the jammed paper is removed completely by using the information in the following steps, you can install the paper tray first, and then close the front cover and the DCP will resume printing automatically.



- If a paper jam occurs when using the optional lower tray unit, check for correct installation of the upper paper tray.
- Always remove all paper from the paper tray and straighten the stack when you add new paper. This helps prevent multiple sheets of paper from feeding through the DCP at one time and reduces paper jams.

- 1 Pull the paper tray completely out of the DCP.
- 2 Pull the jammed paper up and out of the DCP.

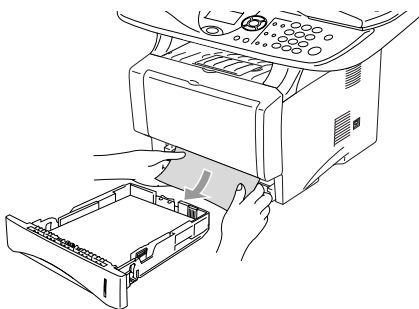

- 3 Press the cover release button and then open the front cover.
- 4 Pull out the drum unit assembly. Pull the jammed paper up and out of the DCP. If you cannot remove the drum unit assembly easily at this time, do not use extra force. Instead, pull the edge of the jammed paper from the paper tray.

If the jammed paper can not be pulled out easily, turn the jam dial towards you so that you gently pull the paper out.

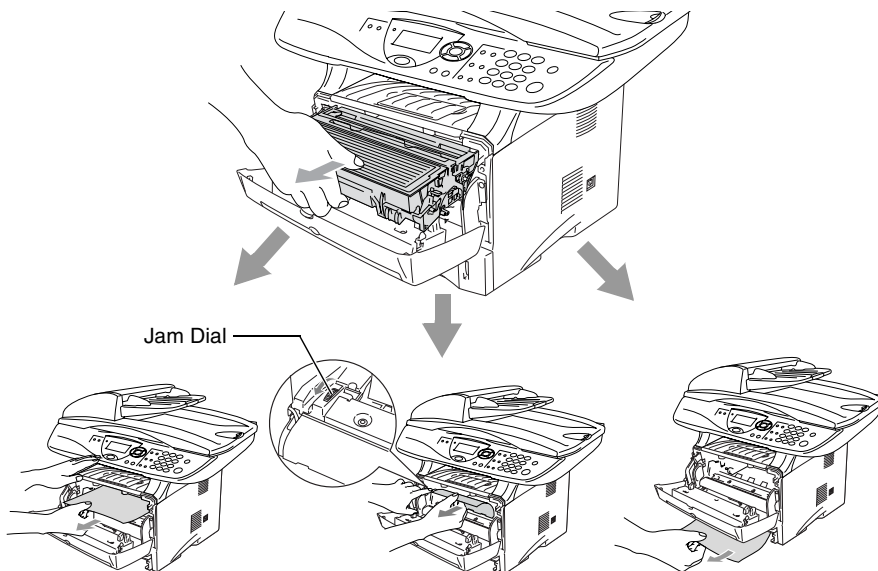

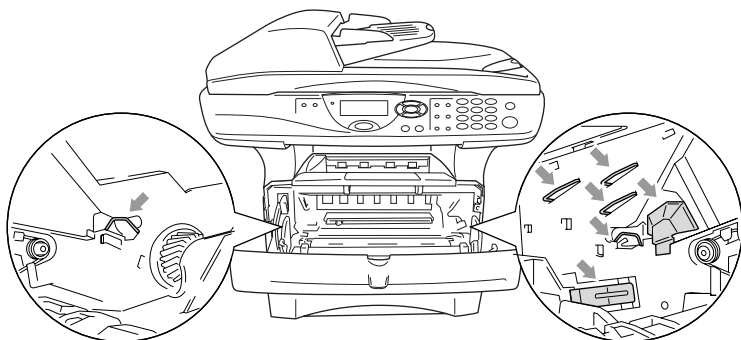

⚠ WARNING

To prevent damage to the DCP caused by static electricity, do not touch the electrodes shown in the following diagram.

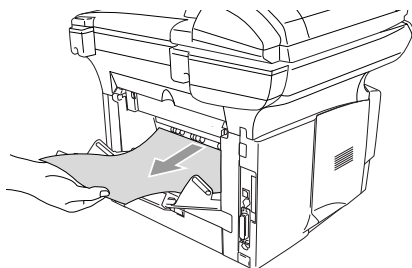

- 5** Open the back output tray. Pull the jammed paper out of the fuser unit. If the paper jam can be cleared, go to Step 7.



-  If you have to pull the paper toward the back of the DCP, the fuser may get dirty with toner powder and it may scatter on the next printouts. Print a few copies of the test page until the scattering of toner stops.

⚠ WARNING

After you have just used the DCP, some internal parts of the DCP are extremely **HOT!** Wait for the DCP to cool down before you touch the internal parts of the DCP.

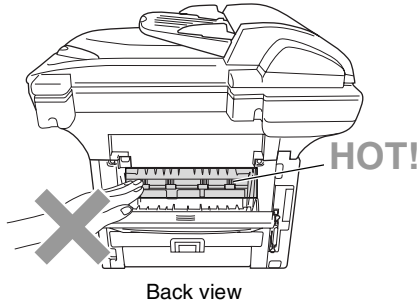

- 6** Open the jam clear cover (fuser cover). Pull the jammed paper out of the fuser unit.

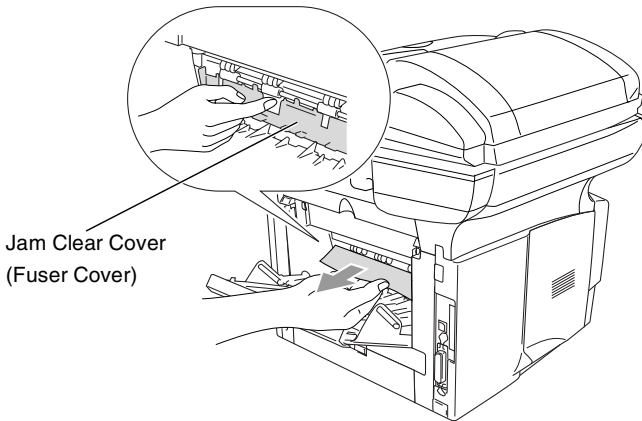

- 7** Close the jam clear cover. Close the back output tray.

- 8** Push the lock lever down and take the toner cartridge out of the drum unit. Take out the jammed paper if there is any inside the drum unit. Then put the toner cartridge back in the drum unit.

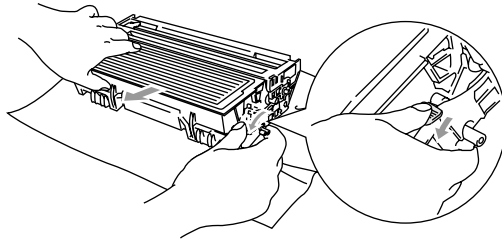

- 9** Put the drum unit assembly back in the DCP.
10 Put the paper tray in the DCP.
11 Close the front cover.

Paper is jammed in the duplex tray (For DCP-8045D)

- 1** Pull the duplex tray and paper tray out of the DCP.

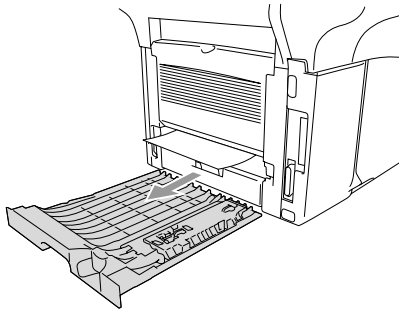

- 2** Pull the jammed paper out of the DCP.

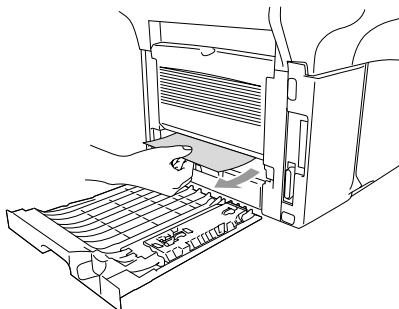

- 3** Put the duplex tray and paper tray back into the DCP.

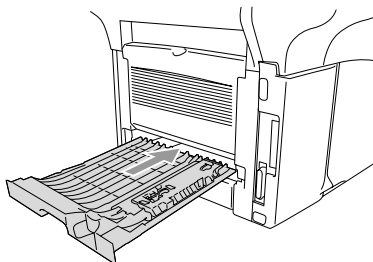

- The **Jam Duplex** message appears if you remove a sheet of paper from the Face Down Output Tray after only one side has printed.
- If the Paper Adjustment Lever for Duplex Printing is not set correctly for the paper size, paper jams may occur and the printing will be out of position on the page. (See *To use Automatic Duplexing for copy and print operations (For DCP-8045D)* on page 2-11.)

If you are having difficulty with your DCP

If the copy looks good, the problem is probably not your DCP. Check the chart below and follow the troubleshooting tips.







DIFFICULTY	SUGGESTIONS
Printing	
Condensed print and horizontal streaks or the top and bottom of sentences are cut off.	If the copy looks bad, clean the scanner area. If there is still problem, call Brother or your dealer for service.
Poor quality print.	See <i>Improving the print quality</i> on page 7-14.
Vertical black lines	Your DCP's primary corona wire for printing may be dirty. Clean your primary corona wire (See <i>Cleaning the drum unit</i> on page 7-23.)
Copy Quality Difficulties	
Vertical streaks appear in copies.	Sometimes you may see vertical streaks on your copies. Either the scanner or the primary corona wire for printing is dirty. Clean them both. (See <i>Cleaning the scanner</i> on page 7-21 and <i>Cleaning the drum unit</i> on page 7-23.)
Printer Difficulties	
The DCP does not print.	Check the following: <ul style="list-style-type: none"> • The DCP is plugged in and the power switch is turned On. (See the Quick Setup Guide.) • The toner cartridge and drum unit are installed properly. (See <i>Replacing the drum unit</i> on page 7-29.) • The interface cable is securely connected between the DCP and computer. (See the Quick Setup Guide.) • Check to see if LCD is showing an error message. (See <i>Error messages</i> on page 7-1.)
The DCP prints unexpectedly or it prints garbage.	Reset the DCP or turn it off and then on again. Check the primary settings in your application software to make sure it is set up to work with your DCP.
The DCP prints first couple of pages correctly, then some pages have text missing.	Your computer is not recognizing the printer's input buffer full signal. Please make sure to connect the DCP cable correctly.
The DCP cannot print full pages of a document. <i>Out of Memory</i> message occurs.	Reduce the printing resolution. Reduce the complexity of your document and try again. Reduce the graphic quality or the number of font sizes within your application software.
My headers or footers appear when I view my document on the screen but do not appear when I print them.	Most laser printers have a restricted area that will not accept print. Usually these are the first two lines and last two lines, leaves 62 printable lines. Adjust the top and bottom margins in your document to allow for this.

DIFFICULTY	SUGGESTIONS
Scanning Difficulties	
TWIN errors appear while scanning.	Make sure the Brother TWIN driver is selected as the primary source. In PaperPort®, click Scan in the File menu and select the Brother TWIN driver.
Software Difficulties	
Cannot install software or print.	Run the MFL-Pro Suite Repair and Install program on the CD-ROM. This program will repair and reinstall the software.
Cannot perform '2 in 1 or 4 in 1' printing.	Check that the paper size setting in the application and in the printer driver are the same.
Cannot print when using Adobe Illustrator.	Try to reduce the print resolution.
When using ATM fonts, some characters are missing or some characters are printed in their place.	If you are using Windows® 98/98SE/Me, select 'Printer Settings' from the 'Start' menu. Select the properties of the 'Brother DCP-8040 or DCP-8045D (USB) Printer'. Click 'Spool Setting' on the 'Details' tab. Select 'RAW' from 'Spool Data Format.'
"Unable to write to LPT1" or "LPT1 already in use" Error Message appears.	<ol style="list-style-type: none"> 1. Make sure the DCP is on (plugged into the AC power outlet and turned the power switch on) and that it is connected directly to the computer using a IEEE-1284 bi-directional parallel cable. The cable must not go through another peripheral device (such as a Zip Drive, External CD-ROM Drive, or Switch box). 2. Make sure the DCP is not displaying an error message on the LCD Display. 3. Make sure no other device drivers, which also communicate through the parallel port, are running automatically when you boot up the computer (such as, drivers for Zip Drives, External CD-ROM Drive, etc.) Suggested areas to check: (<i>Load=, Run=command lines in the win.ini file or the Statup Group</i>) 4. Check with you computer manufacturer to confirm that the computer's parallel port settings in the BIOS are set to support a bi-directional machine; i.e. (Parallel Port Mode – ECP)
"MFC is Busy" or "MFC Connect Failure" Error Message appears.	
"MFC Connect Failure"	If the DCP is not connected to your PC and you have loaded the Brother software, the PC will show "MFC Connect Failure" each time you restart Windows®. You can ignore this message or you can turn it off as follows. Double-click "tool\WarnOFF.REG" from the supplied CD-ROM. The Scan key on the DCP's control panel will not work unless you restart your PC with the DCP connected. To turn it back on. Double-click "tool\WarnON.REG" from the supplied CD-ROM.



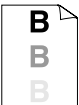



DIFFICULTY	SUGGESTIONS
Paper Handling Difficulties	
The DCP does not load paper. The LCD shows <i>Check Paper</i> or <i>Paper Jam</i> .	Check to see if the <i>Check Paper</i> or <i>Paper Jam</i> message appears on the LCD. If it is empty, load a new stack of paper into the paper tray. If there is paper in the paper tray, make sure it is straight. If the paper is curled, you should straighten it. Sometimes it is helpful to remove the paper, turn the stack over and put it back into the paper tray. Reduce the amount of paper in the paper tray, and then try again. Check that the manual feed mode or MP tray or MP mode is not selected in the printer driver.
The DCP does not feed paper from the manual feed tray.	Reinsert the paper firmly, load one sheet at a time. Make sure that manual feed mode or MP mode is selected in the printer driver.
How can I load envelopes?	You can load envelopes from the manual feed or MP tray. Your application software must be set up to print the envelope size you are using. This is usually done in the Page Setup or Document Setup menu of your software. Refer to your software application manual.
What paper can I use?	You can use plain paper, envelopes, transparencies and labels that are made for laser machines. (For information on paper you can use, See <i>Printer operation keys</i> in Software User's Guide on the CD-ROM.)
How can I clear paper jams?	See <i>Paper jams</i> on page 7-5.
Print Quality Difficulties	
Printed pages are curled.	Thin or thick paper below the standard can cause this problem. Make sure you select the Paper Type that suits the media type you use. (See <i>Setting the Paper Type</i> on page 4-1 and <i>Media Type</i> in Software User's Guide on the CD-ROM.)
Printed pages are smeared.	The Paper Type setting may be incorrect for the type of print media you are using— OR —The print media may be too thick or have a rough surface. (See <i>Setting the Paper Type</i> on page 4-1 and <i>Media Type</i> in Software User's Guide on the CD-ROM.)
Printouts are too light.	Set Toner Save mode to off in the Advance tab in the printer driver. (See <i>Toner Save Mode</i> in Software User's Guide on the CD-ROM.)
Network Difficulties	
I cannot print over the Network	Make sure that your DCP is powered on and is On Line and in Ready mode. Press the Test switch. Then the current settings of the NC-9100h are printed. Verify that the cabling and Network connections are good. If possible, try connecting the DCP to a different port on your hub using a different cable. Check to see if there is any LED activity. The NC-9100h has a two color LED for diagnosing problems.

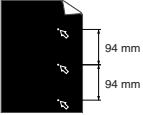
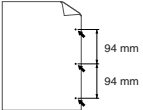
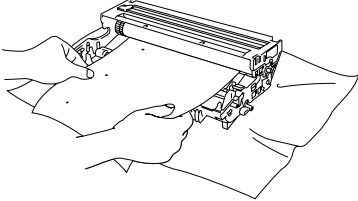
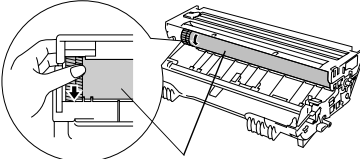
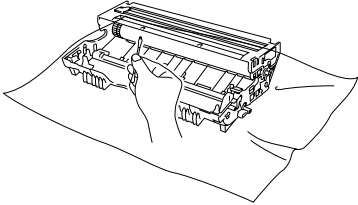

Improving the print quality

This section provides information on the following topics:

Examples of poor print quality	Recommendation
 <p>ABCDEFHG abcdeghijk A B C D a b c d e 0 1 2 3 4</p> <p>Faint</p>	<p>Check the printer's environment. Conditions such as humidity, high temperatures, and so on may cause this print fault. (See <i>Choosing a location</i> on page iv.)</p> <p>If the whole page is too light, Toner Save mode may be on. Turn off Toner Save mode in the printer Properties tab of the driver.</p> <p>—OR—</p> <p>If your DCP is not connected to a computer, turn off Toner Save mode in the DCP itself. (See <i>Toner Save</i> on page 4-4.)</p> <p>Try installing a new toner cartridge. (See <i>Replacing the toner cartridge</i> on page 7-24.)</p> <p>Try installing a new drum unit. (See <i>Replacing the drum unit</i> on page 7-29.)</p>
 <p>ABCDEFHG abcdeghijk A B C D a b c d e 0 1 2 3 4</p> <p>Gray background</p>	<p>Make sure that you use paper that meets the recommended specifications. (See <i>About paper</i> on page 2-1.)</p> <p>Check the printer's environment - high temperatures and high humidity can increase the amount of background shading. (See <i>Choosing a location</i> on page iv.)</p> <p>Use a new toner cartridge. (See <i>Replacing the toner cartridge</i> on page 7-24.)</p> <p>Use a new drum unit. (See <i>Replacing the drum unit</i> on page 7-29.)</p>
 <p>B B B</p> <p>Ghost</p>	<p>Make sure you use paper that meets our specifications. Rough-surfaced paper or thick print media may cause this problem.</p> <p>Make sure that you choose the appropriate media type in the printer driver. (See <i>About paper</i> on page 2-1.)</p> <p>Try using a new drum unit. (See <i>Replacing the drum unit</i> on page 7-29.)</p>
 <p>ABCDEFHG abcdeghijk A B C D a b c d e 0 1 2 3 4</p> <p>Toner specks</p>	<p>Make sure that you use paper that meets our specifications. Rough-surfaced paper may cause the problem. (See <i>About paper</i> on page 2-1.)</p> <p>The drum unit may be damaged. Put in a new drum unit. (See <i>Replacing the drum unit</i> on page 7-29.)</p>
 <p>B B B</p> <p>Hollow print</p>	<p>Make sure that you use paper that meets our specifications. (See <i>About paper</i> on page 2-1.)</p> <p>Choose Thick Paper mode in the printer driver, or use thinner paper than you are currently using.</p> <p>Check the printer's environment because conditions such as high humidity can cause hollow print. (See <i>Choosing a location</i> on page iv.)</p>
 <p>All black</p>	<p>You may clear the problem by cleaning the primary corona wire inside the drum unit by sliding the blue tab. Make sure you return the blue tab to the home position (▲). (See <i>Cleaning the drum unit</i> on page 7-23.)</p> <p>The drum unit may be damaged. Put in a new drum unit. (See <i>Replacing the drum unit</i> on page 7-29.)</p>

Examples of poor print quality	Recommendation
 <p>White Spots on black text and graphics at 94 mm intervals</p>  <p>Black Spots at 94 mm intervals</p>	<p>If the problem is not solved after printing a few pages, the drum unit may have glue from label stock on the OPC drum surface.</p> <p>Clean the drum unit as follows:</p> <ol style="list-style-type: none"> 1 Position the print sample in front of the drum unit, and find the exact position of the poor print.  2 Turn the drum unit gear by hand while looking at the surface of the OPC drum. <p>! Caution Be careful not to touch the photosensitive drum with your fingers.</p>  <p style="text-align: center;">Photosensitive drum</p> 3 When you have located the mark on the drum that matches the print sample, wipe the surface of the OPC drum with a cotton swab until the dust or paper powder on the surface comes off.  <p>! Caution Do not try to clean the surface of the photosensitive drum with a sharp object, such as a ball-point pen, and so on.</p> <p>The drum unit may be damaged. Put in a new drum unit. (See <i>Replacing the drum unit</i> on page 7-29.)</p>

Examples of poor print quality	Recommendation
 <p>Black toner marks across the page</p>	<p>The drum unit may be damaged. Put in a new drum unit. (See <i>Replacing the drum unit</i> on page 7-29.)</p> <p>Make sure that you use paper that meets our specifications. (See <i>About paper</i> on page 2-1.)</p> <p>If you use label sheets for laser printers, the glue from the sheets may sometimes stick to the OPC drum surface. Clean the drum unit. (See <i>Cleaning the drum unit</i> on page 7-23.)</p> <p>Do not use paper that has clips or staples because they will scratch the surface of the drum.</p> <p>If the unpacked drum unit is in direct sunlight or room light, the unit may be damaged.</p>
 <p>White lines across the page</p>	<p>Make sure that you use paper that meets our specifications. A rough surfaced paper or thick print media can cause the problem.</p> <p>Make sure that you select the appropriate media type in the printer driver.</p> <p>The problem may disappear by itself. Try printing multiple pages to clear this problem, especially if the printer has not been used for a long time.</p> <p>The drum unit may be damaged. Put in a new drum unit. (See <i>Replacing the drum unit</i> on page 7-29.)</p>
 <p>Lines across the page</p>	<p>Clean the inside of the printer and the primary corona wire in the drum unit. (See <i>Cleaning the drum unit</i> on page 7-23.)</p> <p>The drum unit may be damaged. Put in a new drum unit. (See <i>Replacing the drum unit</i> on page 7-29.)</p>
 <p>Black lines down the page</p> <p>Printed pages have toner stains down the page.</p>	<p>Clean the primary corona wire of the drum unit.</p> <p>Make sure the primary corona wire cleaner is at the home position (▲).</p> <p>The drum unit may be damaged. Install a new drum unit. (See <i>Replacing the drum unit</i> on page 7-29.)</p> <p>The toner cartridge may be damaged. Put in a new toner cartridge. (See <i>Replacing the toner cartridge</i> on page 7-24.) Make sure that a torn piece of paper is not inside the printer covering the scanner window.</p> <p>The fixing unit may be smudged. Call Customer Service.</p>
 <p>White lines down the page</p>	<p>You may clear the problem by wiping the scanner window with a soft cloth. (See <i>Cleaning the printer</i> on page 7-22.)</p> <p>The toner cartridge may be damaged. Put in a new toner cartridge. (See <i>Replacing the toner cartridge</i> on page 7-24.)</p>
 <p>Page skewed</p>	<p>Make sure the paper or other print media is loaded properly in the paper tray and that the guides are not too tight or too loose against the paper stack.</p> <p>Set the paper guides correctly.</p> <p>If you are using the manual feed tray (or the multi-purpose tray). (See <i>How to load paper</i> on page 2-5.)</p> <p>The paper tray may be too full.</p> <p>Check the paper type and quality. (See <i>About paper</i> on page 2-1.)</p>

Examples of poor print quality	Recommendation
 <p data-bbox="230 293 344 312">Curl or wave</p>	<p data-bbox="432 172 1021 212">Check the paper type and quality. High temperatures and high humidity will cause paper to curl.</p> <p data-bbox="432 217 1021 300">If you don't use the printer very often, the paper may have been in the paper tray too long. Turn over the stack of paper in the paper tray. Also, try fanning the paper stack and then rotating the paper 180° in the paper tray.</p> <p data-bbox="432 304 1021 344">Try printing using the straight-through output path. (See <i>How to load paper</i> on page 2-5.)</p>
 <p data-bbox="199 485 376 504">Wrinkles or creases</p>	<p data-bbox="432 363 766 383">Make sure that paper is loaded properly.</p> <p data-bbox="432 387 981 406">Check the paper type and quality. (See <i>About paper</i> on page 2-1.)</p> <p data-bbox="432 411 1021 451">Try printing using the straight-through output path. (See <i>How to load paper</i> on page 2-5.)</p> <p data-bbox="432 456 1021 496">Turn over the stack of paper in the tray or try rotating the paper 180° in the input tray.</p>



The drum unit is a consumable item and it is necessary to replace it periodically.

Packing and shipping the DCP

Whenever you transport the DCP, use the packing materials that came with your machine. If you do not pack the DCP correctly, you may void your warranty.

- 1 Turn the DCP power switch off.
- 2 Unplug the DCP from the AC outlet.

Lock the Scanner Lock

- 3 Push the Scanner Lock Lever up to lock the scanner. This lever is located on the left of the scanner glass.

Scanner Lock Lever

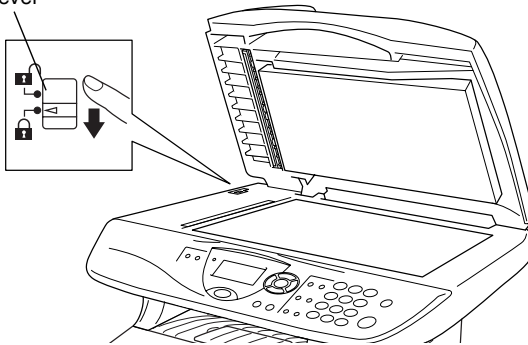

Caution

Damage caused to your DCP by failure to lock the scanner before moving and shipping may void your warranty.

- 4 Open the front cover.

- 5** Remove the drum unit and toner cartridge assembly. Leave the toner cartridge installed in the drum unit.

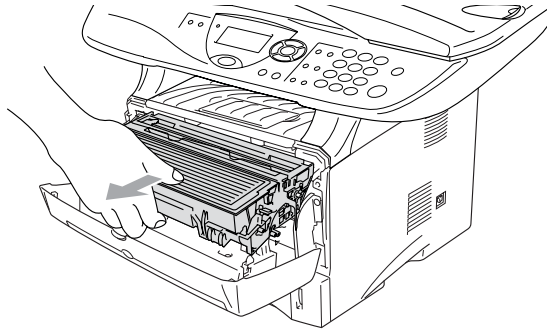

- 6** Place the drum unit and toner cartridge assembly into the plastic bag and seal the bag.

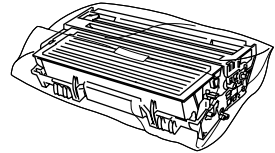

- 7** Close the front cover. Fold down the face-down output tray flap.

- 8** Wrap the DCP in the plastic bag and place it in the original carton with the original packing material.

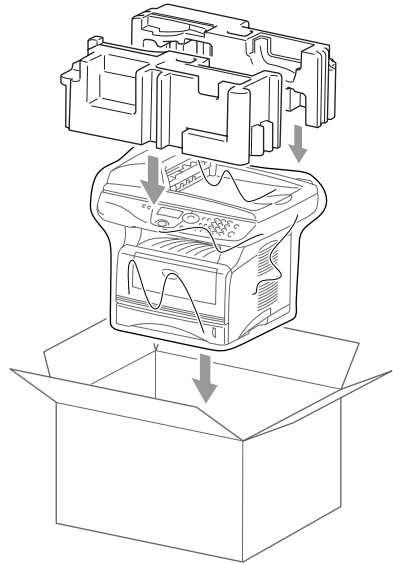
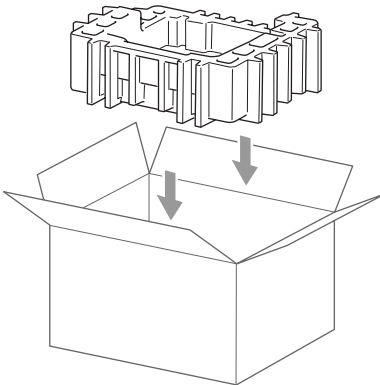

- 9** Pack the drum unit and toner cartridge assembly, AC cord and printed materials in the original carton as shown below:

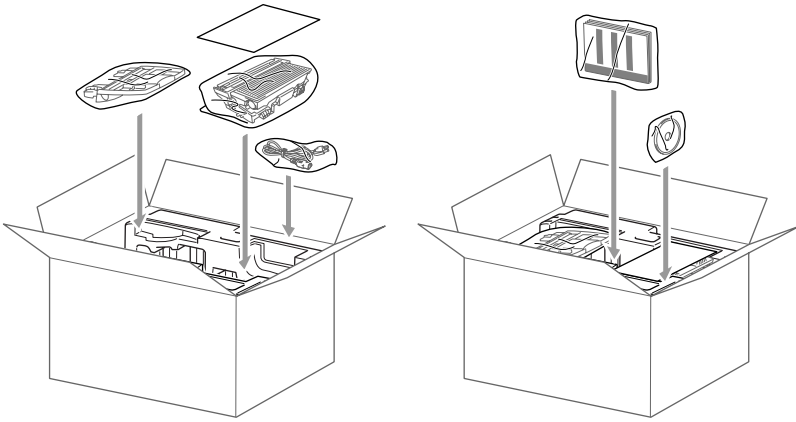

- 10** Close the carton and tape it shut.

Routine maintenance

Cleaning the scanner

Turn the DCP power switch off and lift the document cover. Clean the scanner glass and glass strip with dry cloth and the white film with isopropyl alcohol on a lint free cloth.

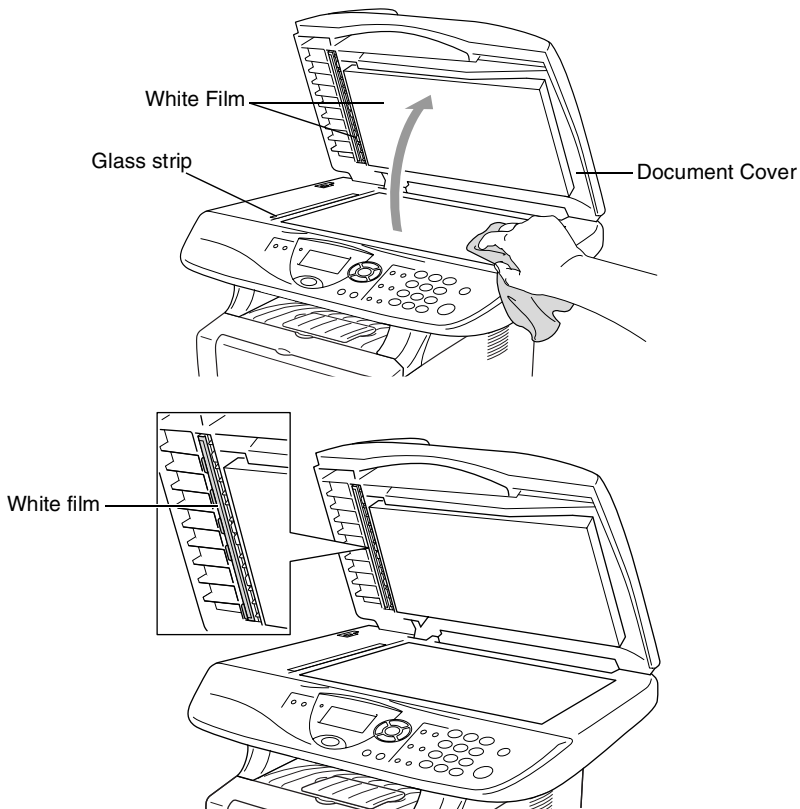

Cleaning the printer

! Caution

- Do *not* use isopropyl alcohol to remove dirt from the control panel. It may crack the panel.
 - Do *not* use isopropyl alcohol to clean the laser scanner window.
 - Do *not* touch the scanner window with your finger.
 - The drum unit contains toner, so handle it carefully. If toner scatters and your hands or clothes get dirty, immediately wipe or wash it off with cold water.
- 1 Turn the DCP power switch off and open the front cover.
 - 2 Remove the drum unit and toner cartridge assembly.

! WARNING

Just after you have used the DCP, some internal parts of the machine are extremely **HOT!** When you open the front cover of the DCP, never touch the shaded parts shown in the diagram below.

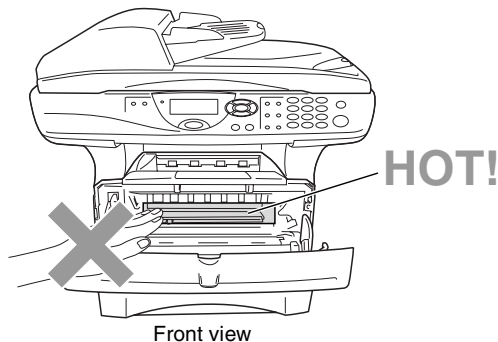

- 3 Gently clean the scanner window by wiping it with a clean soft dry cloth. Do *not* use isopropyl alcohol.

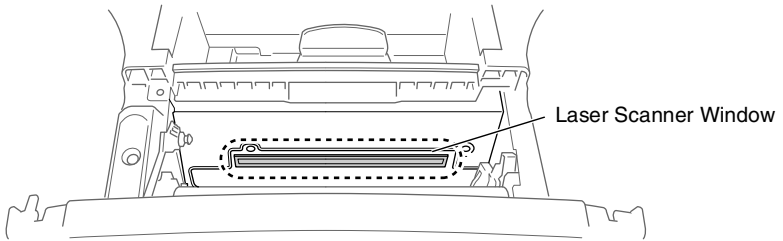

Cleaning the drum unit

We recommend placing the drum unit and toner cartridge assembly on a cloth or large disposable paper to avoid spilling and scattering toner.

- 1 Clean the primary corona wire inside the drum unit by gently sliding the blue tab from right to left several times.
- 2 Return the blue tab and snap it into the Home position (▼).

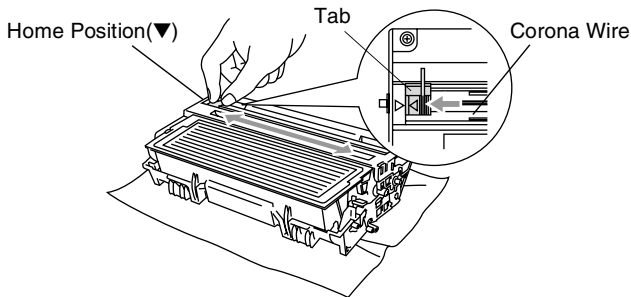

! Caution

If the blue tab is not at the Home position (▼), printed pages may have vertical stripes.

- 3 Reinstall the drum unit and toner cartridge assembly into the DCP. (See *Replacing the drum unit* on page 7-29.)
- 4 Close the front cover.
- 5 Plug in the power cord.

Replacing the toner cartridge

The DCP can print *up to 6,700* pages using a *high yield* toner cartridge. When the toner cartridge is running low, the LCD shows `Toner Low`. The DCP is supplied with a *standard* toner cartridge that must be replaced after approximately 3,500 pages. Actual page count will vary depending on your average type of document (i.e., standard letter, detailed graphics).



It is a good idea to keep a new toner cartridge ready for use when you see the `Toner Low` warning.

Discard the used toner cartridge according to local regulations, keeping it separate from domestic waste. Be sure to seal the toner cartridge tightly so toner powder does not spill out of the cartridge. If you have questions, call your local waste disposal office.

We recommend that you clean the DCP when you replace the toner cartridge.

How to replace the toner cartridge

WARNING

Just after you use the DCP, some internal parts of the machine will be extremely **HOT!** So, never touch the shaded parts shown in the illustration.

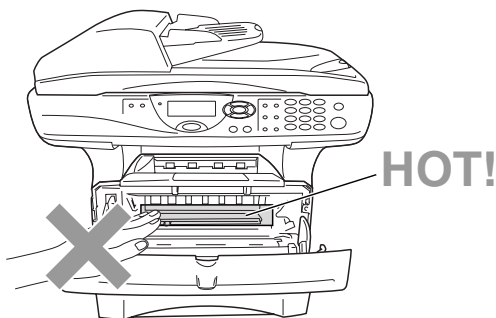

1 Open the front cover and pull out the drum unit.

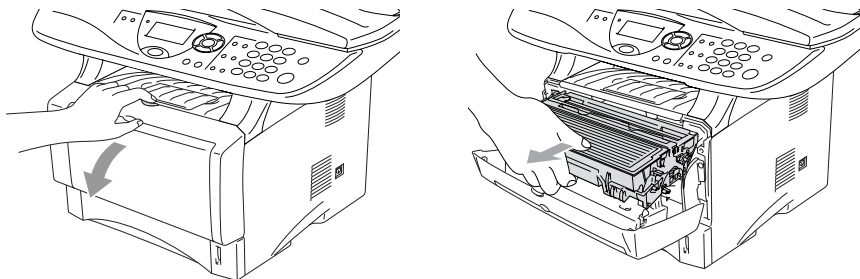

! Caution

- Place the drum unit on a drop cloth or large piece of disposable paper to avoid spilling and scattering the toner.
- To prevent damage to the DCP from static electricity, do not touch the electrodes shown below.

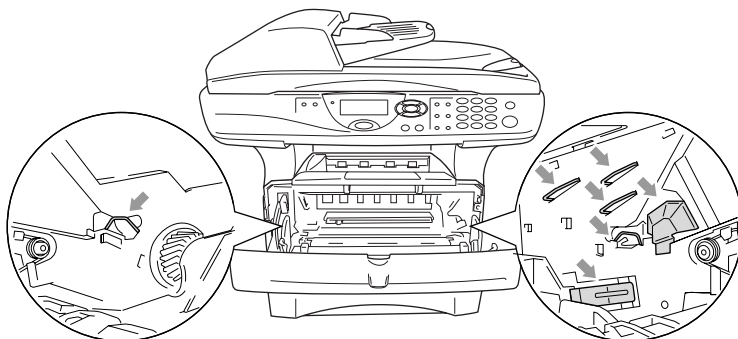

- 2 Hold down the lock lever on the right and pull the toner cartridge out of the drum unit.

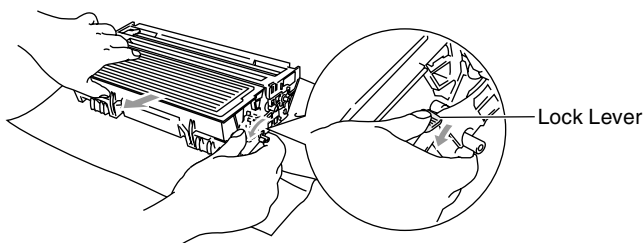

! Caution

Handle the toner cartridge carefully. If toner scatters on your hands or clothes, immediately wipe it off or wash it with cold water.

- 3 Unpack the new toner cartridge. Place the used toner cartridge into the aluminum bag and discard it according to local regulations.

! Caution

- Wait to unpack the toner cartridge until immediately before you install it in the DCP. If a toner cartridge is left unpacked for a long period of time, the toner life is shortened.
- Brother multifunction machines are designed to work with toner of a particular specification and work to a level of optimum performance, when used with genuine Brother toner cartridges. Brother cannot guarantee this optimum performance if toner or toner cartridges of other specifications are used. Brother does not therefore recommend the use of cartridges other than genuine Brother cartridges with this machine nor does it recommend the refilling of empty cartridges with toner from other sources. If damage is caused to parts of this machine as a result of the use of toner or toner cartridges other than genuine Brother products due to the incompatibility or lack of suitability of those products with the machine, any repairs required as a result will not be covered by the warranty.

- 4** Gently rock the toner cartridge from side to side five or six times to distribute the toner evenly inside the cartridge.

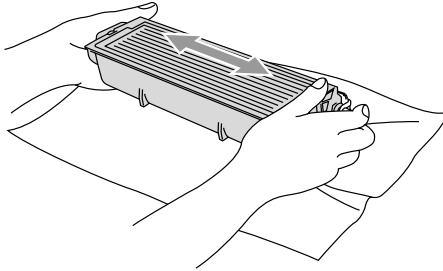

- 5** Remove the protective cover.

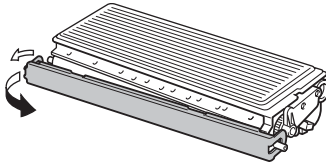

- 6** Insert the new toner cartridge in the drum unit until it clicks into place. If you put it in properly, the lock lever will lift automatically.

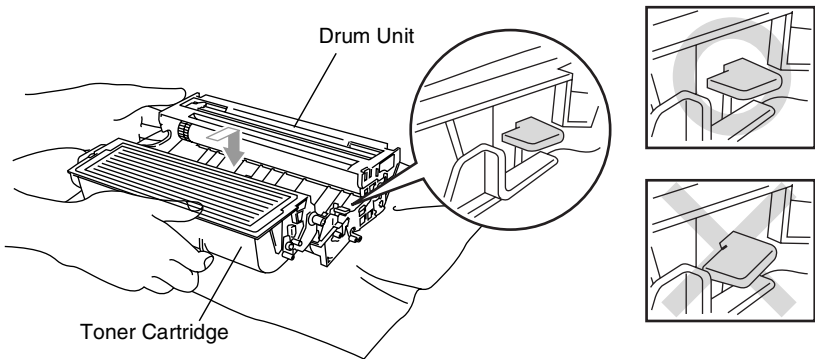

- 7** Clean the primary corona wire inside the drum unit by gently sliding the blue tab from right to left several times. Return the blue tab to the Home position (▼) before reinstalling the drum unit and toner cartridge assembly.

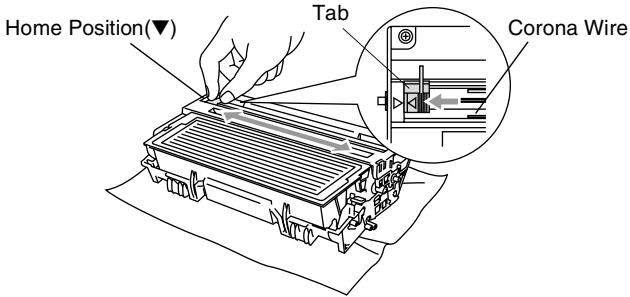

- 8** Reinstall the drum unit and toner cartridge assembly and close the front cover.

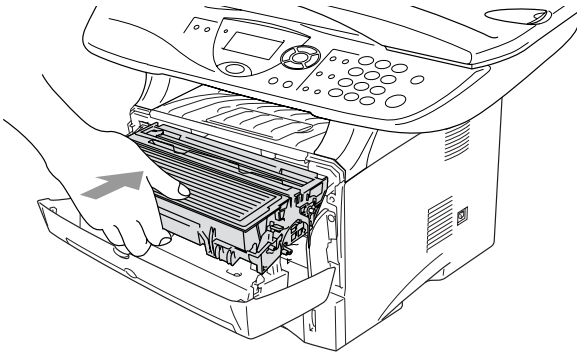

Replacing the drum unit

The DCP uses a drum unit to create print images on paper. If the LCD shows *Change Drum Soon*, the drum unit is near the end of its life and it is time to purchase a new one.

Even if the LCD shows *Change Drum Soon*, you may be able to continue printing without having to replace the drum unit for a while. However, if there is a noticeable deterioration in the output print quality (even before *Change Drum Soon* appears), then the drum unit should be replaced. You should clean the DCP when you replace the drum unit. (See *Cleaning the drum unit* on page 7-23.)

! Caution

When removing the drum unit, handle it carefully because it contains toner. If toner scatters and your hands or clothes get dirty, immediately wipe or wash with cold water.

 The actual number of pages your drum will print may be significantly less than the figure shown on page S-6. Because we have no control over the many factors that determine the actual drum life, we cannot guarantee a minimum number of pages that will be printed by your drum.

! WARNING

Just after you have used the DCP, some internal parts of the DCP are extremely **HOT!** So please be careful.

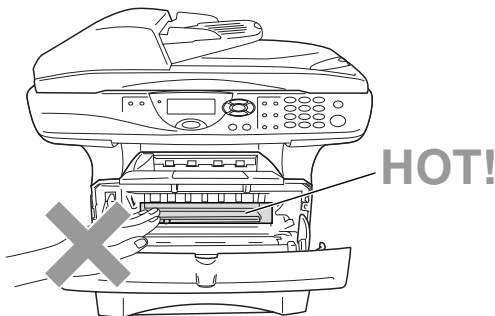

Follow these steps to replace the drum unit:

- 1** Press the cover release button and then open the front cover.
- 2** Remove the old drum unit and toner cartridge assembly. Place it on a drop cloth or disposable paper to avoid scattering toner.

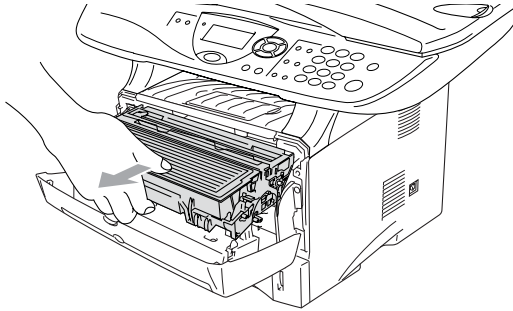

! Caution

To prevent damage to the printer from static electricity, do not touch the electrodes shown below.

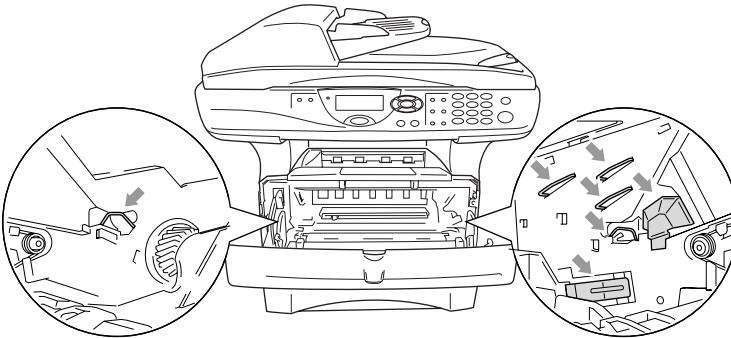

- 3 Hold down the lock lever on the right and pull the toner cartridge out of the drum unit. (See *Replacing the toner cartridge* on page 7-24.)

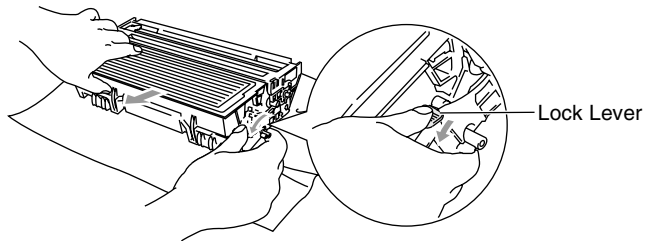

- 4 Discard the used drum unit according to local regulations, keeping it separate from domestic waste. Be sure to seal the drum unit tightly so toner powder does not spill out of the unit. If you have questions, call your local waste disposal office.
- 4 Wait to unpack the new drum unit until immediately before installing it. Place the old drum unit into the plastic bag and discard it according to local regulations.
- 5 Reinstall the toner cartridge into the new drum unit. (See *Replacing the toner cartridge* on page 7-24.)
- 6 Reinstall the new drum unit, keeping the front cover *open*.
- 7 Press **Clear/Back**.
- 8 Press **1** and when the LCD shows *Accepted*, and close the front cover.

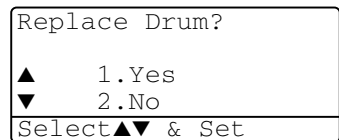

! Caution

If toner scatters and your hands or clothes get dirty, immediately wipe off or wash with cold water.

Checking the drum life

You can see the percentage of the drum's life that remains available.

1 (DCP-8040) Press **Menu, 1, 6**.

—OR—

If you have the optional tray #2,
press **Menu, 1, 7**.

(DCP-8045D) Press **Menu, 1, 7**.

17.Drum Life
Remaining:100%

2 For five seconds, the LCD shows the available percentage of drum life.



Even if the remaining drum life is 0%, you may continue to use the drum unit until you have a print quality problem.

Page Counter

You can see number of total pages, copy pages, print pages and List (total list print) pages that your DCP has printed.

1 (DCP-8040) Press **Menu, 1, 7**.

—OR—

If you have the optional tray #2,
press **Menu, 1, 8**.

(DCP-8045D) Press **Menu, 1, 8**.

18.Page Counter
▲ Total :123456
▼ Copy :120002

2 The LCD shows number of pages for **Total** and **Copy**.

Press  to see **Print** and **List**.

3 Press **Stop/Exit**.

8

Optional accessories

Memory board

The memory board is installed on the main controller board inside the DCP. When you add the optional memory board, it increases the performance for both copier and printer operations.

Model Name	Optional Memory
DCP-8040 (32 MB Standard Memory)	32MB TECHWORKS 12457-0001
DCP-8045D (32 MB Standard Memory)	64MB TECHWORKS 12458-0001
	128MB TECHWORKS 12459-0001

In general, the DIMM must have the following specifications:

Type: 100 pin and 32 bit output

CAS Lantency: 2 or 3

Clock Frequency: 100MHz or more

Capacity: 32, 64, 128MB

Height: 35mm or less

Parity: NONE

DRAM Type: SDRAM 4 Bank

Some DIMMs might not work with this DCP. For the latest information from Brother visit:

<http://solutions.brother.com>

Installing the optional memory board

⚠ WARNING

DO NOT touch the surface of the main board within 15 minutes after turning off the power.

- 1 Turn the DCP power switch off, unplug the DCP power cord from the AC outlet, and then disconnect the interface cable.

⚠ WARNING

Turn the DCP power switch off, before installing (or removing) the memory board.

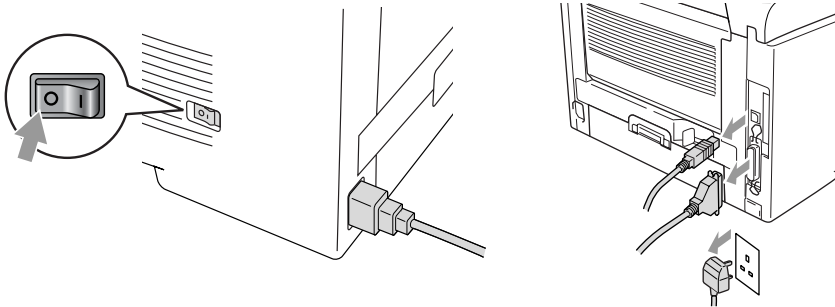

- 2 Remove the side cover. Loosen the two screws, and then remove the metal shield plate.

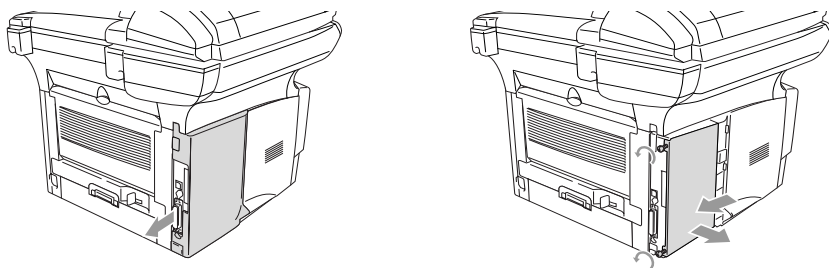



- 3 Unpack the DIMM and hold it by the edges.

⚠ WARNING

DIMM boards can be damaged by even a small amount of static electricity. Do not touch the memory chips or the board surface. Wear an antistatic wrist strap when you install or remove the board. If you do not have an antistatic wrist strap, frequently touch the bare metal on the printer.

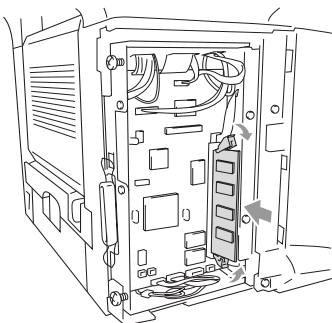
- 4 Hold the DIMM with your fingers on the side edges and your thumb on the back edge. Line up the notches on the DIMM with the DIMM slot. (Check that the locks on each side of the DIMM slot are open or facing outwards.)



- 5 Press the DIMM straight into the slot (press firmly). Make sure the locks on each side of the DIMM click into place. (To remove a DIMM, you must release the locks.)
 - 6 Put the metal plate back on and secure the metal plate with the two screws.
 - 7 Put the side cover back on.
 - 8 Reconnect any additional interface cables that you removed.
 - 9 Reconnect the power cable and then turn on the DCP power switch.
-  ■ To check that you have installed the DIMM correctly, print the printer settings by using the selection in the driver and check the printout to make sure it shows the additional memory.
- You can check the current memory size to press **Menu, 1, 8** (DCP-8040), **Menu, 1, 9** (DCP-8045D).

 **WARNING**

If the Status LED turns Red for a Service Error, please call your dealer or Brother authorized service center.

Network (LAN) board

When you add the optional Network (LAN) Board (NC-9100h), you can connect your DCP into the network to use the Network Scanner, Network Printer and Network Management operations.

WARNING

DO NOT touch the surface of the main board within 15 minutes after turning off the power.

For more details about how to configure the Network board, please see the NC-9100h Network User's Guide on the CD-ROM supplied with the DCP.

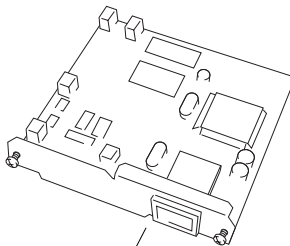

NC-9100h
Print/Fax Server

Before starting installation

Be careful when handling the NC-9100h. There are many delicate electronic components that are susceptible to damage from static electricity. To avoid such damage, use the following precautions when handling the board.

- Leave the NC-9100h in its anti-static bag until you are ready to install it.
- Make sure that you are adequately grounded before touching the NC-9100h. Use an anti-static wrist strap and a grounding mat if possible. If you do not have an anti-static wrist strap, touch the bare metal surface on the back of the machine before handling the NC-9100h.
- Avoid moving around the work area in order to eliminate static charge build-up.
- If possible, do not work on a carpeted area.
- Do not flex the board and do not touch the components on the card.

Tools Required:

Phillips Screwdriver 

Step 1: Hardware installation

WARNING

DO NOT touch the surface of the main boards within 15 minutes after turning off the power.

- 1 Turn the DCP power switch off, unplug the DCP power cord from the AC outlet, and then disconnect the interface cable.

⚠ WARNING

Turn the DCP power switch off, before installing (or removing) the NC-9100h board.

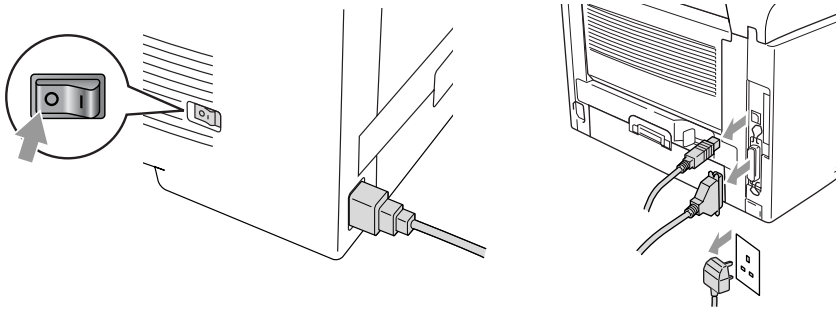

- 2** Remove the side cover. Loosen the two screws, and then remove the metal shield plate.

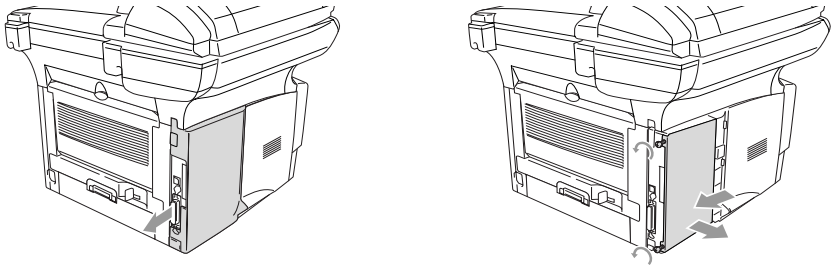

- 3** Loosen the two screws, and then remove the metal cover plate.

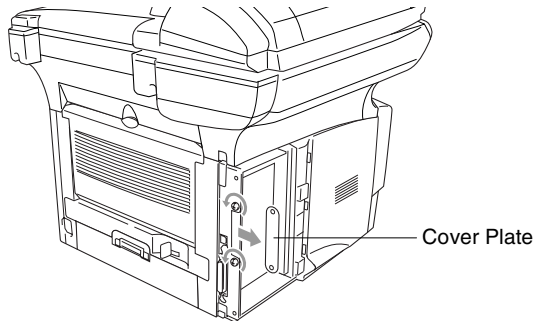

- 4 Plug the NC-9100h into connector P1 located on the main board as shown in the illustration (press firmly) and secure the NC-9100h with the two screws.

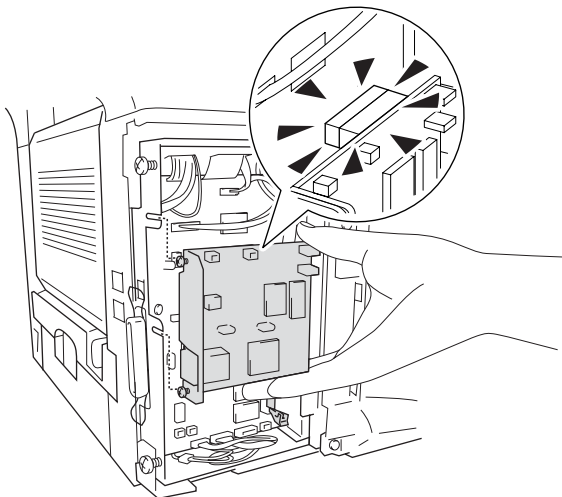

- 5 Put the metal shield plate back on and secure it with the two screws.
- 6 Put the side cover back on.
- 7 Reconnect any additional interface cables that you removed.
- 8 Reconnect the power cable and then turn on the DCP power switch.
- 9 Press the Test switch and print a network configuration page. (See *TEST SWITCH* on page 8-10.)

Step 2: Connecting the NC-9100h to an Unshielded Twisted Pair 10BASE-T or 100BASE-TX Ethernet Network

To connect the NC-9100h to a 10BASE-T or 100BASE-TX Network, you must have an Unshielded Twist Pair Cable. One side of the cable must be connected to a free port on your Ethernet hub and the other side must be connected to the 10BASE-T or 100BASE-TX connector (an RJ45 Connector) of the NC-9100h.

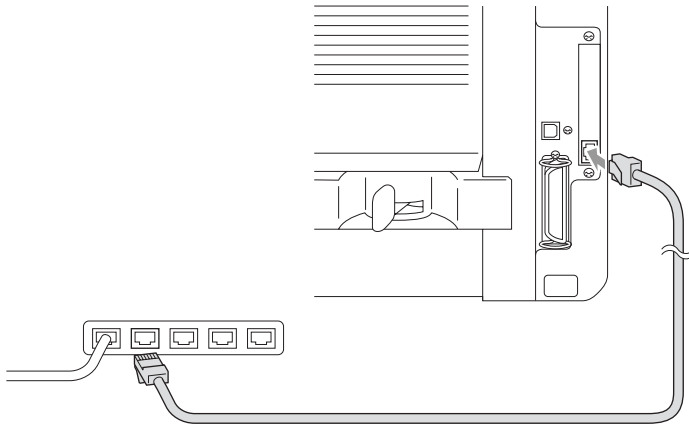

Verifying successful hardware Installation:

Plug in the AC power cord. After initialization and warm-up (this may take several seconds), the DCP will come to a Ready state.

LED

No light:

If both of the two LEDs are off, then the print server is not connected to the network.

Link/Speed LED is orange: Fast Ethernet

This Link/Speed LED will be orange if the print server is connected to a 100BASETX Fast Ethernet network.

Link/Speed LED is green: 10 BASE T Ethernet

This Link/Speed LED will be green if the print server is connected to a 10 BASE T Ethernet.

Active LED is yellow:

The Active LED will blink if the print server is receiving or transmitting data.



If there is a valid connection to the network, the LED will blink orange or green.

TEST SWITCH

Short push: Prints the network configuration page.

Long push (more than 5 seconds): Reset the network configuration back to the default settings.

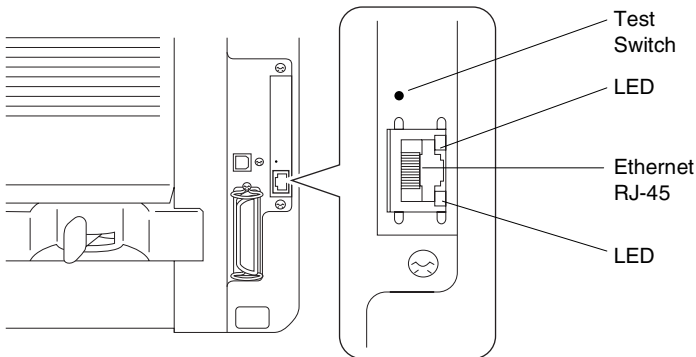

To set up the DCP on the Network, see the *NC-9100h Network User's Guide* on the CD-ROM.

Paper Tray #2

You can purchase the Paper Tray #2 accessory (LT-5000) to use as a third paper source. Tray #2 holds up to 250 sheets of 80 g/m² paper.

Paper Tray #2	Holds approx. 250 sheets of 80 g/m ²
Basis Weight	60 to 105 g/m ²
Moisture Content	4% to 6% by weight
We Recommend:	Xerox Premier 80 g/m ²
Cut sheet:	Xerox Business 80 g/m ²
	Mode DATACOPY 80 g/m ²
	IGEPA X-Press 80 g/m ²

G Glossary

- ADF (Automatic Document Feeder)** Documents can be placed in the ADF and scanned one page at a time automatically.
- Beeper** The sound the keys make when they are pressed, an error occurs.
- Beeper volume** Volume setting for the beep when you press a key or make an error.
- Contrast** Setting to compensate for dark or light documents, by copies of dark documents lighter and light documents darker.
- Drum Unit** A printing device for the DCP.
- Gray scale** The shades of gray available for copying photographs.
- LCD (liquid crystal display)** The display screen on the DCP that shows interactive messages during On-Screen Programming.
- Menu mode** Programming mode for changing your DCP's settings.
- MFL-Pro Suite** Turns your DCP into a printer and a scanner using the DCP.
- OCR (optical character recognition)** The bundled ScanSoft® OmniPage® software application converts an image of text to text you can edit.
- Photo resolution** A resolution setting that uses varying shades of gray for the best representation of photographs.
- Scanning** The process of sending an electronic image of a paper document into your computer.
- System Setup List** A printed report that shows the current settings of the DCP.
- Toner cartridge** An accessory that holds toner for the drum unit on Brother laser models.

Toner Save A process that causes less toner to be affixed to the page to extend the life of the toner assembly. This will make the receiving document significantly lighter.

True Type fonts The fonts that are used in the Windows® operating systems. If you install the Brother True Type fonts, more types of fonts will be available for Windows® applications.

S Specifications

Product description

The DCP-8040 and DCP-8045D are **3 in 1** Multi-Function Centers: Printer, Copier and Color Scanner. The DCP-8045D includes Duplex Printing.

General

Memory Capacity	32 MB
Optional Memory	1 DIMM slot; Memory expandable up to 160 MB
Automatic Document Feeder (ADF)	Up to 50 pages Temperature: 20°C - 30°C Humidity: 50% - 70% Paper: 75 g/m ² A4 size
Paper Tray	250 Sheets (80 g/m ²)
Multi-Purpose Tray	50 Sheets (80 g/m ²) (DCP-8045D only)
Manual Feed Tray	Single sheet (80 g/m ²) (DCP-8040 only)
Printer Type	Laser
Print Method	Electrophotography by semiconductor laser beam scanning
LCD (Liquid Crystal Display)	22 characters × 5 lines
Warm-up	Max. 18 seconds at 23°C
Power Source	220 - 240V AC 50/60Hz
Power Consumption	Average Operating (Copying): 450W or less (25°C) Peak: 1090W or less Sleep: 14W or less 16W or less (when Network LAN board (NC-9100h) is installed.) Standby: 85W or less (25°C)
Dimensions	532 × 444 × 469 (mm)
Weight	Without Drum/Toner Unit: DCP-8040: 16.6 kg DCP-8045D: 18.1 kg
Noise	Operating: 53 dB A or less Standby: 30 dB A or less

General (continued)

Temperature	Operating: 10 - 32.5°C
	Storage: 0 - 40°C
Humidity	Operating: 20 to 80% (without condensation)
	Storage: 10 to 90% (without condensation)

Print media

Paper Input

Paper Tray

- Paper type:
Plain paper, recycled paper and transparencies, envelopes (Manual Feed/Multi-purpose Tray)
- Paper size:
A4, Letter, Legal, B5 (ISO), B5 (JIS), Executive, A5, A6, B6 (ISO)
Weight: 60 - 105 g/m² (Paper Tray)
For more details, see *Paper specifications for each paper tray* on page 2-4.
- Maximum paper tray capacity: Approx. 250 sheets of 80 g/m² plain paper
- Maximum multi-purpose tray capacity: Approx. 50 sheets of 80 g/m² plain paper (DCP-8045D only)

Manual Feed Tray/Multi-Purpose Tray

- Paper size:
Width: 69.8 - 220.0 mm
Height: 116.0 - 406.4 mm
Weight: 60 - 161 g/m²

Paper Output

Up to 150 sheets of plain paper (Face down print delivery to the output paper support)

Copy

Color/Monochrome

Monochrome

Copy Speed

Up to 20 copies/minute (A4 paper)

Multiple Copies

Stacks or Sorts up to 99 pages

Enlarge/Reduce

25% to 400% (in increments of 1%)

Resolution

Max. 1200 x 600 dpi

Scanner

Color/Monochrome

Color/Monochrome

TWAIN Compliant

Yes (Windows® 98/98SE/Me/2000 Professional and Windows NT® Workstation Version 4.0)

Mac OS® 8.6 - 9.2/Mac OS® X 10.2.1 or greater

WIA Compliant

Yes (Windows® XP)

Resolution

Up to 9,600 × 9,600 dpi (interpolated)*

Up to 600 × 2,400 dpi (optical)

* Maximum 1200 x 1200 dpi scanning with Windows® XP
(resolution up to 9600 x 9600 dpi can be selected by using the Brother scanner utility)

Document Size

ADF Width: 148 mm to 216 mm

ADF Height: 148 mm to 356 mm

Scanner Glass Width: Max. 216 mm

Scanner Glass Height: Max. 356 mm

Scanning Width

212 mm

Gray Scale

256 levels



- Scanning directly to a networked PC is available with Windows® 98/98SE/Me/2000 Professional and XP.
- Mac OS® X scanning is supported in Mac OS® X 10.2.1 or greater.

Printer

Emulation	PCL6 (Brother Printing System for Windows® emulation mode of HP LaserJet) and BR-Script (PostScript®) Level 3
Printer Driver	Windows® 98/98SE/Me/2000 Professional/XP and Windows NT® Workstation Version 4.0 driver supporting Brother Native Compression mode and bi-directional capability Apple® Macintosh® QuickDraw® Driver and PostScript (PPD) for Mac OS® 8.6 - 9.2/ Mac OS® X 10.1/10.2.1 or Greater
Resolution	HQ1200 (Max. 2400 × 600 dots/inch)
Print Quality	Normal printing mode Economy printing mode (saves toner usage)
Print Speed	Up to 20 pages/minute A4 size (when loading paper from paper tray)
Duplex Printing	Up to 9 pages/minute: (DCP-8045D only) (9 sides per minute, 4.5 sheets per minute)
First Print	Up to 12 seconds (using A4 size paper in paper tray)

Interfaces

Interface	Recommended Cable
Parallel	A bi-directional shielded parallel cable that is IEEE 1284 compliant and not longer than 2 m.
USB	A Hi-Speed USB 2.0 cable that is not longer than 2 m.



- Please make sure that you use a Hi-Speed USB 2.0 certified cable if your computer uses a Hi-Speed USB 2.0 interface.
- Even if your computer has a USB 1.1 interface you can connect the DCP.

Computer requirements

Minimum System Requirements						
Computer Platform & Operating System Version		Processor Minimum Speed	Minimum RAM	Recommended RAM	Available Hard Disk Space	
					for Drivers	for Applications ^{*2}
Windows ^{®*1} Operating System	98, 98SE	Pentium II or equivalent	32 MB	64 MB	90 MB	130 MB
	Me		64 MB	128 MB		
	NT [®] Workstation 4.0					
	2000 Professional		128 MB	256 MB	150 MB	220 MB
	XP					
Apple [®] Macintosh [®] Operating System	Mac OS [®] 8.6 - 9.2 (Printing and Scanning)	All base models meet minimum Requirements		64 MB	80 MB	200 MB
	Mac OS [®] X 10.1/10.2.1 or greater (Printing and Scanning ^{*3})		128 MB	160 MB		
NOTE: All registered trademarks referenced herein are the property of their respective companies.						
For the latest drivers, go to the Brother Solutions Center at http://solutions.brother.com/						

*1 Microsoft[®] Internet Explorer 5 or greater.

*2 Application Software is different for Windows[®] and Macintosh[®].

*3 Scanning is supported in 10.2.1 or greater.

Consumable items

Toner Cartridge Life Expectancy

TN-3030: Standard Toner Cartridge - Up to 3,500* pages

TN-3060: High Yield Toner Cartridge - Up to 6,700* pages

*(when printing letter size or A4 paper at 5% print coverage)



Toner life expectancy will vary depending upon the type of average print job.

Drum Unit Life Expectancy

Up to 20,000 pages/drum unit (DR-3000)



There are many factors that determine the actual drum life, such as temperature, humidity, type of paper, toner you use and number of pages per print job.

Network (LAN) board (NC-9100h)

DCP-8040 (Option)
DCP-8045D (Option)

When you add the optional Network (LAN) Board (NC-9100h), you can connect your DCP into the network to use the Network Scanner, Network Printer and Network Management software.

Support for:

Windows® 98/Me/NT® 4.0/2000/XP
Novell NetWare 3.X, 4.X, 5.X
Mac OS® 8.6 - 9.2, X 10.1/10.2.1 or Greater
Ethernet 10/100 BASE-TX Auto Negotiation
TCP/IP, IPX/SPX, AppleTalk, DLC/LLC, NetBIOS
RARP, BOOTP, DHCP, APIPA, WINS
LPR/LPD, Port9100, SMTP/POP3
SMB(NetBIOS/ IP), IPP, SSDP
mDNS, FTP
SNMP, MIBII as well as Brother private MIB
TELNET, HTTP, TFTP

Included Utilities:

BRAdmin Professional and Web Based
Management



- Scanning directly to a networked PC is not supported in Windows NT® and Mac OS®.
- BRAdmin Professional is not supported in Mac OS®.

Optional External Wireless Print/Scan Server (NC-2200w)

NC-2200w External Wireless Print/Scan Server (Optional)

Network types

Support for

Protocols

Connecting the optional External Wireless Print/Scan Server (NC-2200w) to your MFC will allow you to print and scan over a wireless network.

IEEE802.11b wireless LAN

Windows® 98/98SE/Me/2000/XP and Windows NT®
Mac OS® X 10.2.4 or greater

TCP/IP

ARP, RARP, BOOTP, DHCP, APIPA (Auto IP),
WINS/NetBIOS, DNS, LPR/LPD, Port9100,
SMB Print, IPP, RawPort, mDNS,
TELNET, SNMP, HTTP



You can assign the scan key to one networked computer only.

Index

A

- ADF (automatic document feeder), using 1-10
- ADF cover 7-4

C

- Cleaning (routine maintenance)
 - drum unit 7-23
 - printer 7-22
 - scanner 7-21
- control panel, overview 1-6
- Copy
 - contrast 5-20
 - default settings, changing 5-20
 - Duplex/N in 1 5-12
 - Enlarge/Reduce 5-7
 - enter Copy mode 5-1
 - keys 5-6
 - multiple 5-4
 - paper 2-1
 - Quality (type of document) 5-9
 - scanner glass 5-4
 - single 5-3, 5-4
 - Sort (ADF only) 5-9
 - temporary settings 5-2, 5-6
 - Tray Select 5-11
 - tray use 4-7
 - using ADF 5-3

D

- Drum unit
 - checking remaining life 7-32
 - replacing 7-29

- Duplex/N in 1 key 5-12
 - Duplex/1 in 1 5-17
 - Duplex/2 in 1 5-19
 - Duplex/4 in 1 5-19

E

- Ecology
 - Scanner lamp 4-5
 - Sleep Time 4-5
- Envelopes 2-3
- Error messages on LCD 7-1
 - Check Paper 7-1
 - Out of Memory 7-2
 - while scanning a document 5-5

G

- Gray scale S-3

H

- HELP 3-1

J

- Jams
 - document 7-4
 - paper 7-5

L

- LAN Configuration 3-8, 3-9
- LCD (Liquid Crystal Display)
 - LCD Contrast 4-8

M

- Maintenance, routine 7-21
- Menu table 3-1
- Multi-purpose tray (MP tray) 2-1

P

Page Counter	7-32
Paper	S-2
capacity	2-3
jam	7-4
Size	4-3
Print	
area	5-1
difficulty	7-11
improving the print quality	7-14
jams	7-5
resolution	S-4
specifications	S-4
Print media	2-1

Q

Quality key (copying)	5-6
-----------------------------	-----

R

Reducing	
copies	5-7
Resolution	
print	S-4
Scan	S-3

S

Safety Instructions	ii, 6-4
Scanner Lamp	4-5
Scanner Lock	7-18
Shipping the machine	7-18

T

Temporary Copy Settings ...	5-6
Toner cartridge	
replacing	7-24
Tray use, setting	
copy	4-7
Troubleshooting	7-1
error messages on LCD ...	7-1

if you are having difficulty	
paper handling	7-13
printer difficulties	7-11

V

Volume, setting	
beeper	4-4

At your side.
brother®



UK/IRE/SAF/PAN NORDIC
LF6335004