

FAX-1360

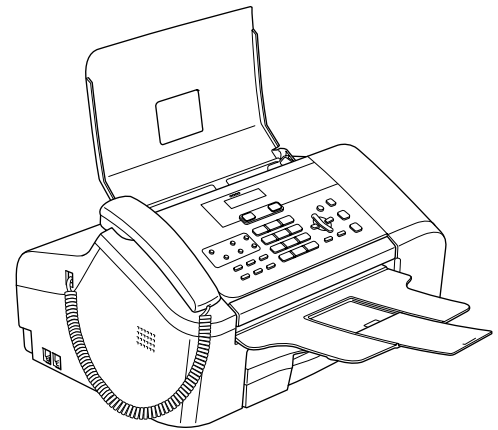





Before you can use the machine, you must set up the hardware.
Please read this Quick Setup Guide for the correct setup procedure.

Setting Up the Machine

Setup is Complete!

Keep this Quick Setup Guide and the User's Guide in a convenient place for quick and easy reference at all times.



Symbols used in this guide

 Warning	 Caution	 Improper Setup
Warnings tell you what to do to prevent possible personal injury.	Cautions specify procedures you must follow or avoid to prevent possible damage to the machine or other objects.	Improper Setup icons alert you to devices and operations that are not compatible with the machine.
 Note	 User's Guide	
Notes tell you how you should respond to a situation that may arise or give tips about how the current operation works with other features.	Indicates reference to the User's Guide we have supplied.	

Carton components

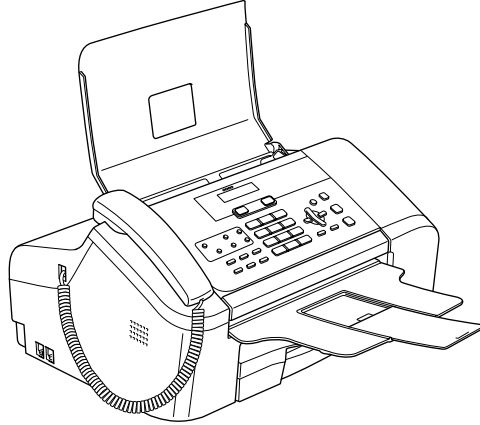
Carton components may vary from one country to another.
Save all packing materials and the carton in case for any reason you must ship your machine.

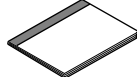
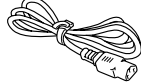
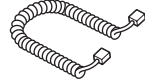

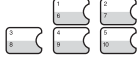
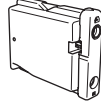
 Quick Setup Guide	 User's Guide	 Power Cord	 Handset Curled Cord
 Telephone Handset	 Telephone Line Cord	 One Touch Labels	 Black (LC960BK) Ink Cartridge

Control panel

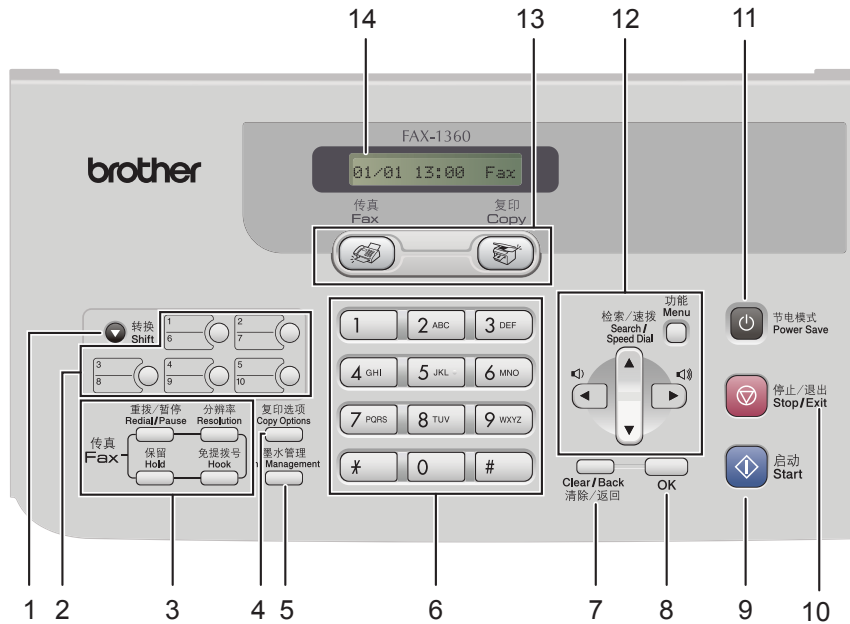

- | | |
|--------------------------|---------------------------------|
| 1 Shift | 8 OK key |
| 2 One Touch keys | 9 Start key |
| 3 Fax and Telephone keys | 10 Stop/Exit key |
| 4 Copy Options key | 11 Power Save key |
| 5 Ink Management key | 12 Menu keys |
| 6 Dial Pad | 13 Mode keys |
| 7 Clear/Back key | 14 LCD (Liquid Crystal Display) |

Note

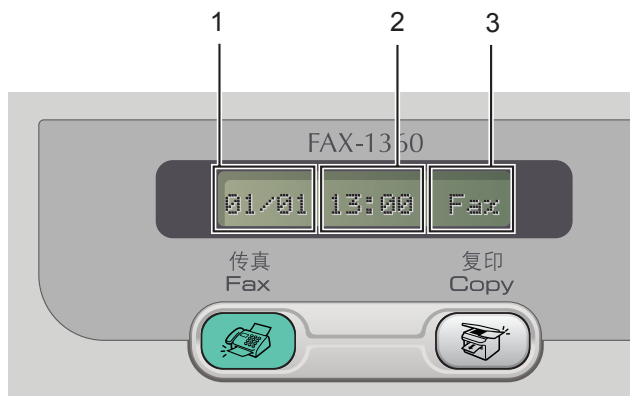

- | |
|----------------|
| 1 Date |
| 2 Time |
| 3 Receive mode |

When the machine is idle (not being used) it will return to the default display shown above. The default display shows the date, time, and the current receive mode.



For the details of the control panel, see Control panel overview in Chapter 1 of the User's Guide.

1 Removing the protective parts

- 1 Remove the protective tape.

2 Installing the Handset

- 1 Connect the curled handset cord to the machine and the other end to the handset.

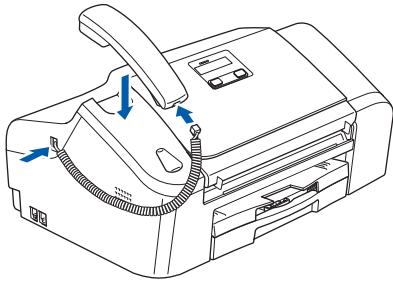

3 Opening the document support and document tray

- 1 Open the document support (①) and the document tray (②) and then pull out the extension (③).

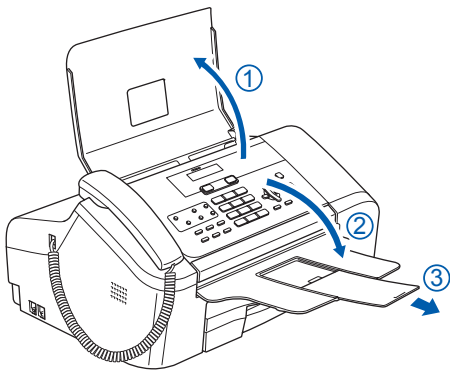

4 Loading paper

-  You can load up to 100 sheets of 80 g/m² (20lb) paper.
For details, see *Acceptable paper and other media* in Chapter 2 of the User's Guide.

- 1 Pull the paper tray completely out of the machine. If the paper support flap (1) is open, close it. Open the output paper tray cover (2).

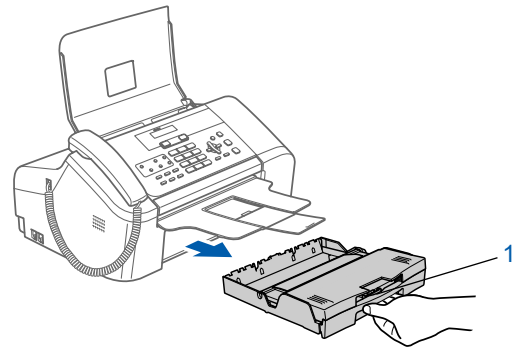

- 2 Press and hold the universal guide release button (1) as you slide out the front of the paper tray to match the paper size you are using.

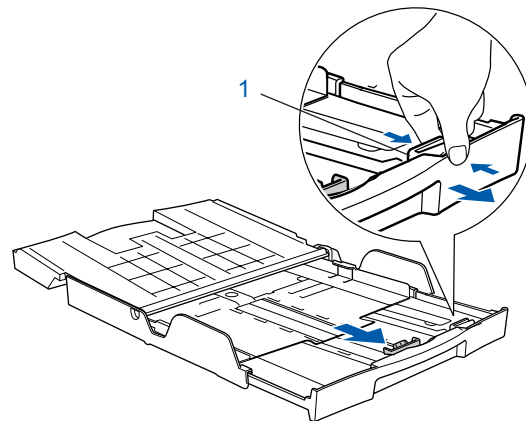

- 3 Press and slide the paper side guides (1) and paper length guide (2) to fit the paper size.

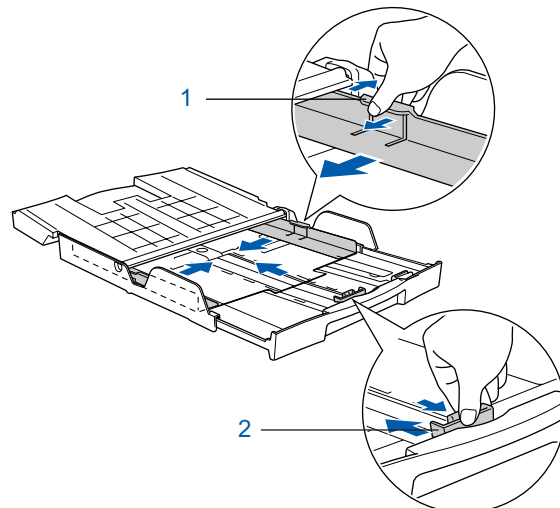

Setting Up the Machine

- 4** Fan the stack of paper well to avoid paper jams and misfeeds.

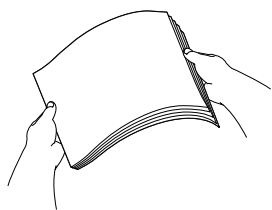

- 5** Gently put the paper into the paper tray print side down and top edge first. Check that the paper is flat in the tray.

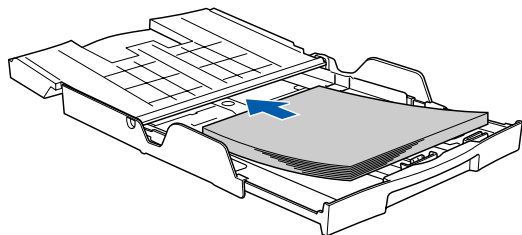

- 6** Gently adjust the paper side guides with both hands and the paper length guide to fit the paper. Make sure that the paper guides touch the edges of the paper.

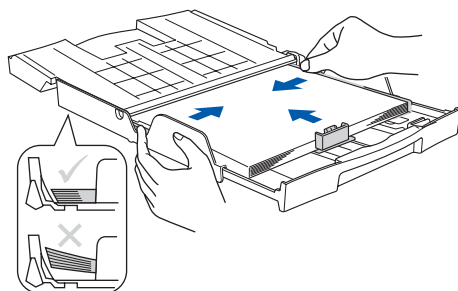

 **Note**

Be careful that you do not push the paper in too far; it may lift at the back of the tray and cause paper feed problems.

- 7** Close the output paper tray cover (1) and slide it forward.

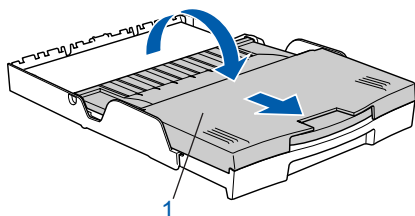

- 8** Slowly push the paper tray completely into the machine.

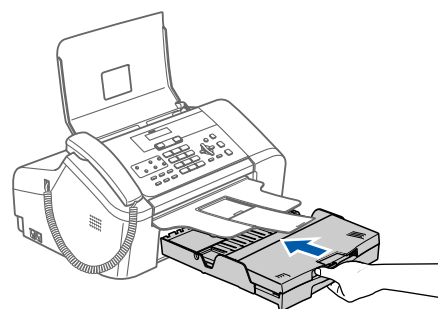

- 9** While holding the paper tray in place, pull out the paper support (1) until it clicks and unfold the paper support flap (2).

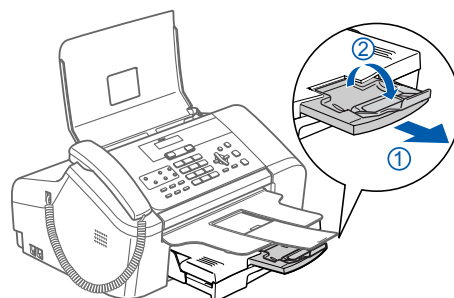

 **Note**

Do not use the paper support flap for Legal size paper.

5 Connecting the phone line

- 1 Connect the telephone line cord. Connect one end of the telephone line cord to the socket on the machine marked **LINE** and the other end to a modular wall socket.

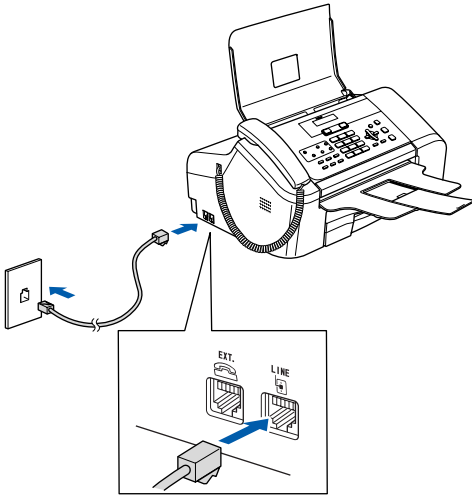

Note

If you are sharing one phone line with an external telephone, connect it as shown below.

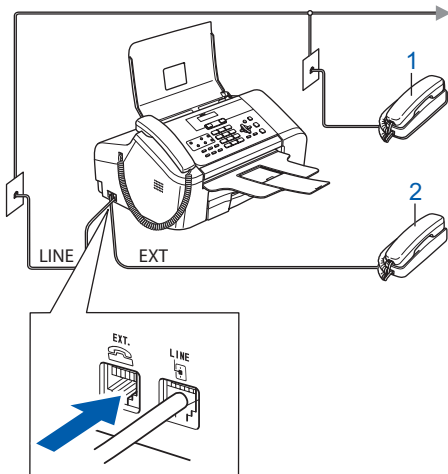

- 1 Extension telephone
- 2 External telephone

Note

If you are sharing one phone line with an external telephone answering machine, connect it as shown below.

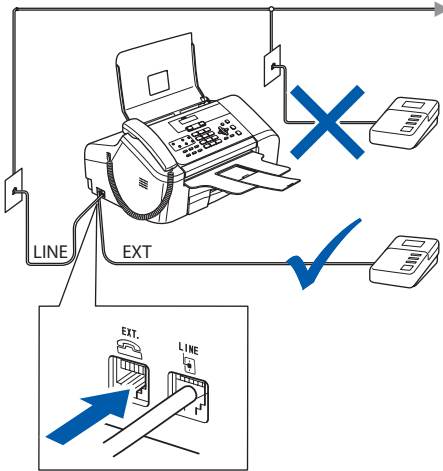

Set the receive mode to 'External TAD' if you have an external answering machine. For details, see *Connecting an external TAD (telephone answering device)* in Chapter 7 of the User's Guide.

6 Connecting the power cord

- 1 Connect the power cord.

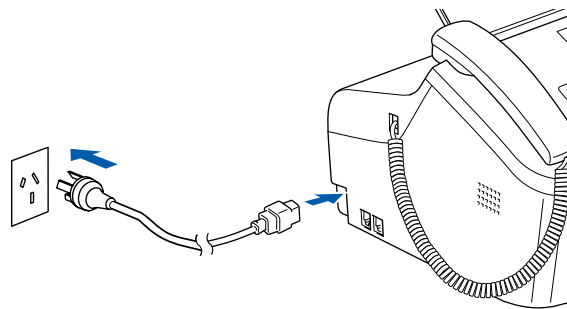

Warning

- The machine must be fitted with an earthed plug.
- Since the machine is grounded through the power outlet, you can protect yourself from potentially hazardous electrical conditions on the telephone network by keeping the power cord connected to your machine when you connect it to a telephone line. Similarly, you can protect yourself when you want to move your machine by disconnecting the telephone line first and then the power cord.

Setting Up the Machine

7 Installing the ink cartridge

Warning

If ink gets in your eyes, wash them out with water at once, and if irritation occurs consult a doctor.

- 1 Make sure that the power is turned on. The LCD shows:

No Cartridge

- 2 Open the ink cartridge cover (1).

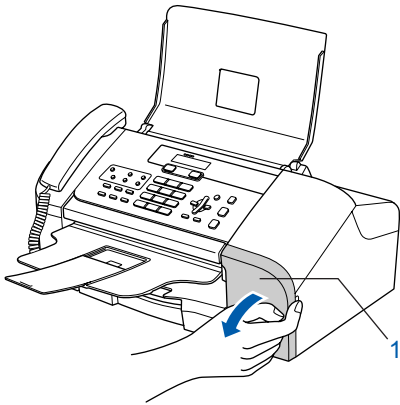

- 3 Pull the lock release lever down and remove the yellow protective part (1).

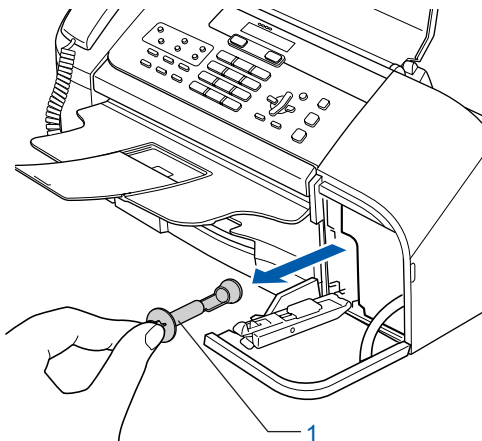
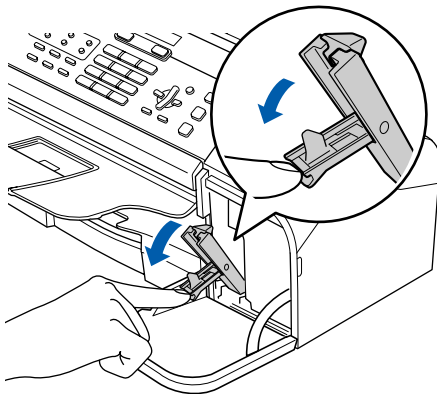

Note

Do not throw away the yellow protective part. You will need it if you transport the machine.

- 4 Take out the ink cartridge.

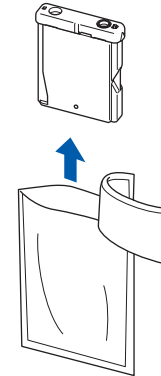

- 5 Carefully remove the protective yellow cap (1).

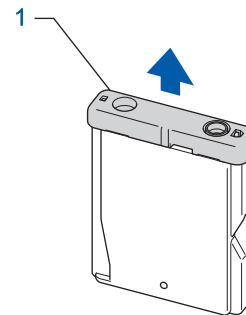

Improper Setup

DO NOT touch the area shown in the illustration below.

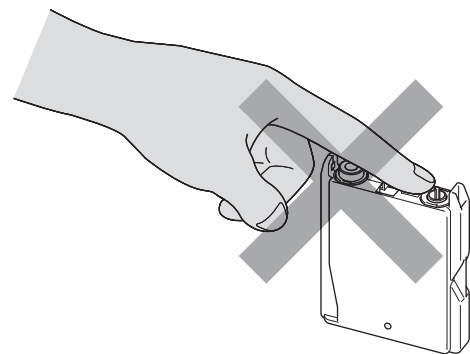

Note

If the protective yellow cap comes off when you open the bag, the cartridge will not be damaged.

- 6** Install the ink cartridge in the direction of the arrow on the label.

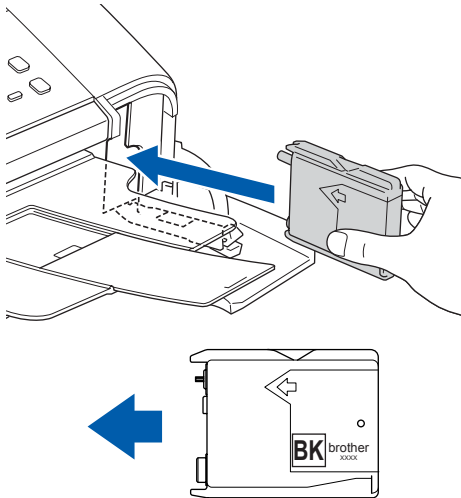

- 7** Lift the lock release lever and gently push until it clicks, and then close the ink cartridge cover.

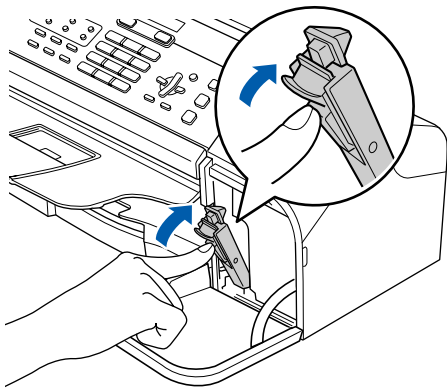

Note

If the LCD shows *Install Black* after you install the ink cartridge, check that the ink cartridge is installed correctly.

The machine will clean the ink tube system for use for the first time. The cleaning process will last approximately two minutes.
The LCD shows:

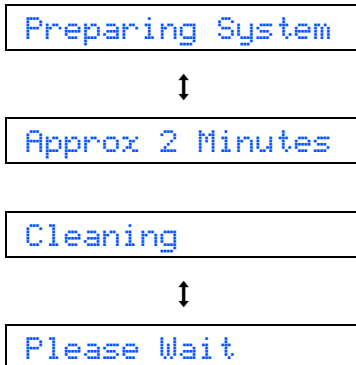

Caution

- DO NOT take out the ink cartridge if you do not need to replace it. If you do so, it may reduce the ink quantity and the machine will not know the quantity of ink left in the cartridge.
- DO NOT shake the ink cartridge. If ink stains your skin or clothing, wash with soap or detergent at once.
- DO NOT repeatedly insert and remove the cartridge. If you do so, ink may seep out of the cartridge.
- Once you open an ink cartridge, install it in the machine and use it up within six months of installation. Use unopened ink cartridges by the expiration date written on the cartridge package.
- DO NOT dismantle or tamper with the ink cartridge, this can cause the ink to leak out of the cartridge.
- Brother multifunction machines are designed to work with ink of a particular specification and will work to a level of optimum performance when used with genuine Brother branded ink cartridges. Brother cannot guarantee this optimum performance if ink or ink cartridges of other specifications are used. Brother does not therefore recommend the use of cartridges other than genuine Brother branded cartridges with this machine or the refilling of empty cartridges with ink from other sources. If damage is caused to the print head or other parts of this machine as a result of using incompatible products with this machine, any repairs required as a result may not be covered by the warranty.

8 Print quality check

- 1** After the cleaning cycle is finished, the LCD shows:

Set Paper and



Press Start

- 2** Make sure paper is loaded in the paper tray. Press **Start**. The machine starts printing the Print Quality Check Sheet (only during initial ink cartridge installation).

Setting Up the Machine

- 3** Check the quality of the block on the sheet.

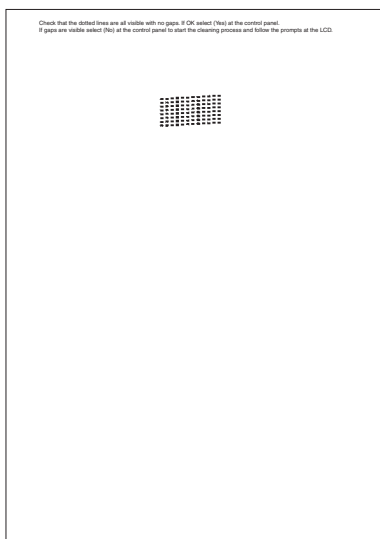

⊘ Improper Setup

Avoid touching the printed surface of the paper immediately after printing, the surface may not be completely dry and may stain your fingers.

- 4** The LCD shows:

Is Quality OK?



1.Yes 2.No

- 5** Do one of the following:

- If all lines are clear and visible, press **1** (Yes) on the dial pad to finish the quality check.
- If you can see missing short lines, press **2** (No) on the dial pad and go to step **6**.

OK

Poor

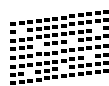
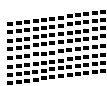

- 6** The LCD shows:

Start Cleaning?



1.Yes 2.No

- 7** Press **1** (Yes), the machine will then start cleaning.

- 8** After cleaning is finished, press **Start**. The machine starts printing the Print Quality Check Sheet again and goes back to step **3**.

9 Setting the LCD contrast

You can adjust the LCD contrast for a sharper and more vivid display. If you are having difficulty seeing the LCD from your position, we recommend changing the contrast setting for improved viewing.

- 1** Press **Menu**.
- 2** Press **1**.
- 3** Press **5**.
- 4** Press **▲** or **▼** to choose **Dark** or **Light**.
- 5** Press **OK**.
- 6** Press **Stop/Exit**.

Contrast:Light



Contrast:Dark

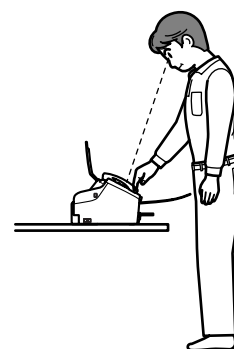

10 Setting the date and time

The machine displays the date and time, and if you set up the station ID, the date and time displayed on your machine will be printed on every fax you send.

- 1 Press **Menu**.
- 2 Press **0**.
- 3 Press **2**.
- 4 Enter the last two digits of the year on the dial pad, and then press **OK**.

Year: 2007

(e.g. Enter **0 7** for 2007.)

- 5 Enter the two digits for the month on the dial pad, and then press **OK**.

Month: 03

(e.g. Enter **0 3** for March.)

- 6 Enter the two digits for the day on the dial pad, and then press **OK**.

Day: 01

(e.g. Enter **0 1** for the first day of the month.)

- 7 Enter the time in 24-hour format on the dial pad, and then press **OK**.

Time: 15:25

(e.g. Enter **1 5, 2 5** for 3:25 P.M.)

- 8 Press **Stop/Exit**.



To confirm the current date and time, print out the Users Settings Report. See Printing Reports in the User's Guide.

11 Setting your station ID

You should store your name and fax number to be printed on all fax pages that you send.

- 1 Press **Menu**.
- 2 Press **0**.
- 3 Press **3**.
- 4 Enter your fax number (up to 20 digits) on the dial pad, and then press **OK**. To enter a "+" for international codes, press *****. For example, to enter the Chinese dialling code "+86", press *****, **8, 6** and then the rest of your number.

Fax: +86XXXXXXXXXX

- 5 Enter your name (up to 20 characters) using the dial pad, and then press **OK**.

Name: _



Note

- See the following chart for entering your name.
- If you need to enter a character that is on the same key as the last character, press to move the cursor to the right.
- If you entered a letter incorrectly and want to change it, press or to move the cursor under the incorrect character, press **Clear/Back**.

Press key	One time	Two times	Three times	Four times
2	A	B	C	2
3	D	E	F	3
4	G	H	I	4
5	J	K	L	5
6	M	N	O	6
7	P	Q	R	S
8	T	U	V	8
9	W	X	Y	Z

- 6 Press **Stop/Exit**.



Note

If you make a mistake and want to start again, press **Stop/Exit** and go back to step 1.



For details, see Entering Text in Appendix C of the User's Guide.

12 Setting tone or pulse dialling mode

Your machine comes set for a Tone dialling service. If you have a Pulse dialling service (rotary), you need to change the dialling mode.

- 1 Press **Menu**.
- 2 Press **0**.
- 3 Press **4**.
- 4 Press **▲** or **▼** to choose **Pulse (or Tone)**. Press **OK**.
- 5 Press **Stop/Exit**.

13 Choosing a Receive Mode

There are four possible receive modes: **Fax Only**, **Fax/Tel**, **Manual** and **External TAD**.

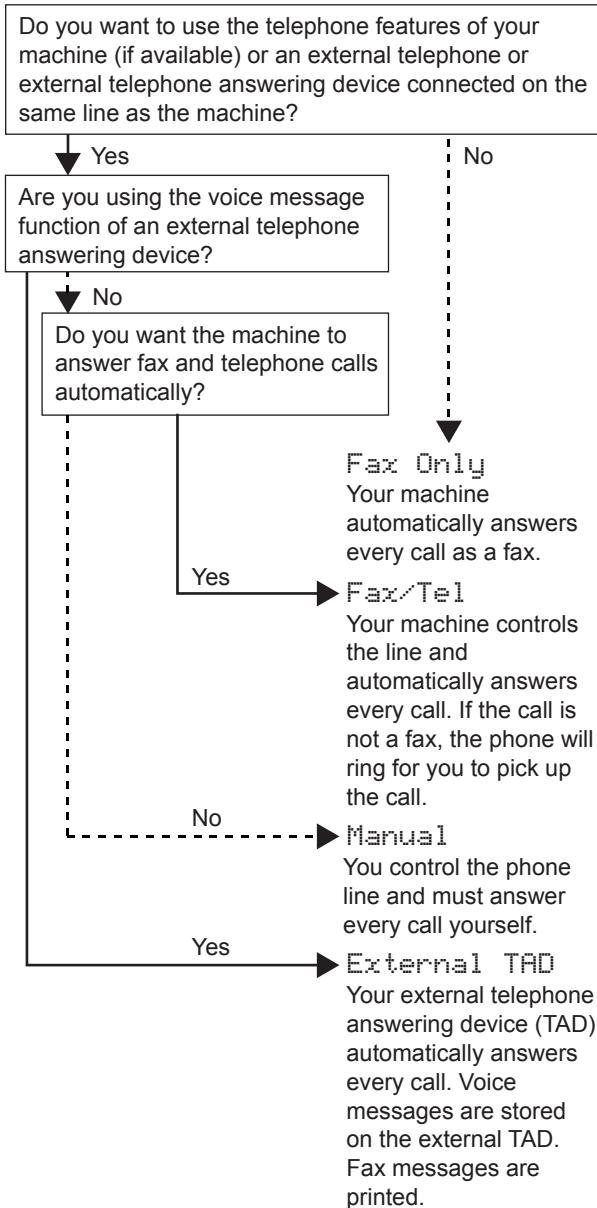

- 1 Press **Menu**.
- 2 Press **0**.
- 3 Press **1**.
- 4 Press **▲** or **▼** to choose the mode. Press **OK**.
- 5 Press **Stop/Exit**.



For details, see *Using receive modes in Chapter 6 of the User's Guide*.

Replacement consumables

Ink cartridge

Black
LC960BK

Trademarks

The Brother logo is a registered trademark of Brother Industries, Ltd.

Brother is a registered trademark of Brother Industries, Ltd.

All other brand and product names mentioned in this manual are trademarks or registered trademarks of their respective companies.

Compilation and Publication

Under the supervision of Brother Industries Ltd., this manual has been compiled and published, covering the latest product descriptions and specifications.

The contents of this manual and the specifications of this product are subject to change without notice.

Brother reserves the right to make changes without notice in the specifications and materials contained herein and shall not be responsible for any damages (including consequential) caused by reliance on the materials presented, including but not limited to typographical and other errors relating to the publication.

This product is designed for use in a Professional Environment.

Copyright and License

©2006 Brother Industries, Ltd.

brother®

ENG