



# Safety and Legal

DCP-J125/J315W/J515W/J715W  
MFC-J220/J265W/J410/J415W/J615W

Please read this booklet before attempting to operate the machine, or before attempting any maintenance. Failure to follow these instructions may result in an increased risk of fire, electrical shock, burns or suffocation.

## Symbols and conventions used in the documentation

The following symbols and conventions are used throughout the documentation.

<b>Bold</b>	Bold typeface identifies specific buttons on the machine's control panel, or on the computer screen.
<i>Italics</i>	Italicized typeface emphasizes an important point or refers you to a related topic.
Courier New	Text in the Courier New font identifies messages on the LCD of the machine.

### WARNING

WARNING indicates a potentially hazardous situation which, if not avoided, could result in death or serious injuries.

### CAUTION

CAUTION indicates a potentially hazardous situation which, if not avoided, may result in minor or moderate injuries.

### IMPORTANT

IMPORTANT indicates a potentially hazardous situation which may result in property-damage-only accidents or loss of product functionality.



Notes tell you how you should respond to a situation that may arise or give tips about how the operation works with other features.



Electrical Hazard icons alert you to possible electrical shock.



Improper Setup icons alert you to devices and operations that are not compatible with the machine.

Follow all warnings and instructions marked on the machine.



### Note

The illustrations in this guide show the MFC-J615W.

# Compilation and Publication Notice

Under the supervision of Brother Industries, Ltd. this manual has been compiled and published, covering the latest product descriptions and specifications.

The contents of this manual and the specifications of this product are subject to change without notice.

Brother reserves the right to make changes without notice in the specifications and materials contained herein and shall not be responsible for any damages (including consequential) caused by reliance on the materials presented, including but not limited to typographical and other errors relating to the publication.

# To use the machine safely

## ⚠ WARNING



DO NOT place the machine near heaters, air conditioners, water, chemicals or devices that contain magnets or generate magnetic fields.



Plastic bags are used in the packing of your machine. To avoid the danger of suffocation, keep these bags away from babies and children.



DO NOT use flammable substances, any type of spray, or an organic solvent/liquid that contains alcohol or ammonia to clean the inside or outside of the machine. Refer to Basic User's Guide.



Never push objects of any kind into this product through cabinet slots, since they may touch dangerous voltage points or short out parts resulting in the risk of fire or electric shock. If metal objects, water or other liquids get inside the machine, immediately unplug the machine from the electrical socket. Call your Brother dealer or Brother Customer Service.



Never touch telephone wires or terminals that are not insulated unless the telephone line has been unplugged at the wall socket. Never install telephone wiring during a lightning storm. Never install a telephone wall socket in a wet location. (MFC only)

This machine should be connected to an adjacent grounded AC power source within the range indicated on the rating label.

---

DO NOT handle the plug with wet hands. Doing this might cause an electrical shock.

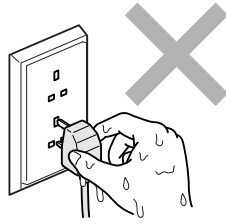

Always make sure the plug is fully inserted.

---

This machine is equipped with a 3-wire grounded plug. This plug will only fit into a grounded power outlet. This is a safety feature. If you are unable to insert the plug into the outlet, call your electrician to replace your obsolete outlet. DO NOT defeat the purpose of the grounded plug.

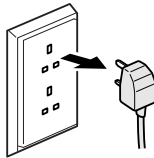

---

DO NOT connect it to a DC power source or inverter. If you are not sure, contact a qualified electrician.

---

DO NOT attempt to service this machine yourself because opening or removing covers may expose you to dangerous voltage points and other risks and may void your warranty. Call your Brother dealer or Brother Customer Service.

---

## **⚠ CAUTION**

Put your machine on a flat, stable surface that is free of vibration and shocks, such as a desk.

---

Put the machine near a telephone socket and a standard grounded electrical socket.

---

Choose a dry, well ventilated location where the temperature remains between 10 °C and 35 °C. Slots and openings in the casing and the back or bottom are provided for ventilation. To ensure reliable operation of the machine and to protect it from overheating, these openings must not be blocked or covered.

---

Some areas of the machine can cause injury if covers (shaded) are closed with force. Take care when placing your hand in the areas shown in the illustrations.

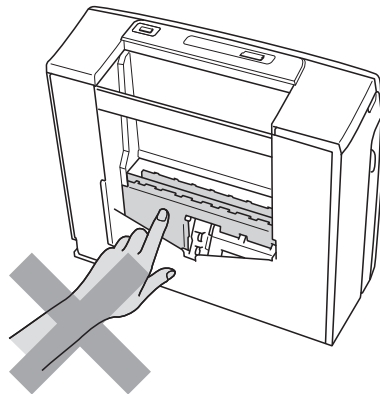
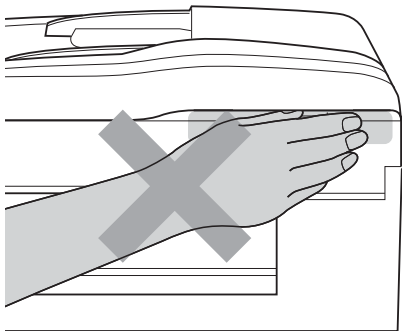
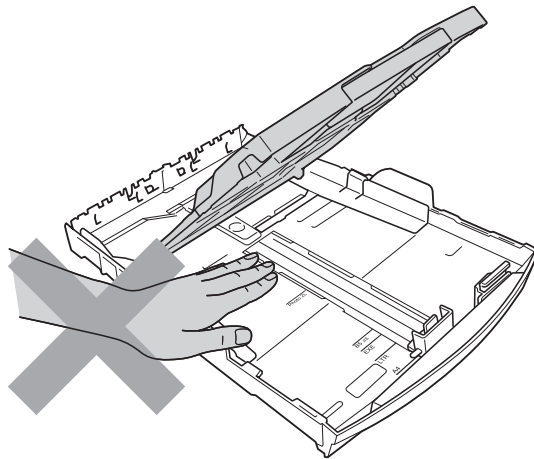
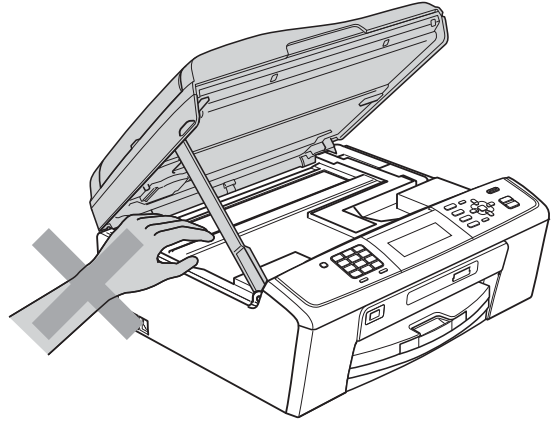

---

DO NOT carry the machine by holding the scanner cover or the Jam Clear Cover.

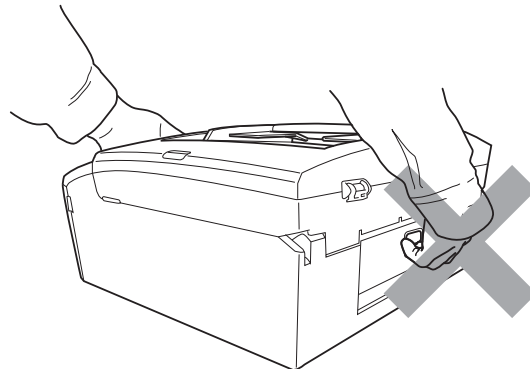

---

If the machine becomes unusually hot, releases smoke, generates any strong smells, or if you accidentally spill any liquid on it, immediately unplug the machine from the electrical socket. Call your Brother dealer or Brother Customer Service.

---

If the machine has been dropped or the casing has been damaged, unplug this machine from the power socket and call your Brother dealer or Brother Customer Service.

## ! IMPORTANT

- DO NOT put objects on top of the machine.
- If the machine does not operate normally when the operating instructions are followed, adjust only those controls that are covered by the operating instructions. Incorrect adjustment of other controls may result in damage and will often require extensive work by a qualified technician to restore the machine to normal operation.
- Use of controls, adjustments or performance of procedures other than those specified in the documentation supplied with the machine may result in hazardous radiation exposure.

### Note

- DO NOT place anything in front of the machine that will block received faxes. DO NOT place anything in the path of received faxes. (MFC only)
  - Wait until pages have exited the machine before picking them up.
-

# Product Warranty & Liability

## Approval Information (MFC only)

---

THIS EQUIPMENT IS DESIGNED TO WORK WITH A TWO WIRE ANALOGUE PSTN LINE FITTED WITH THE APPROPRIATE CONNECTOR.

Brother advises that this product may not function correctly in a country other than where it was originally purchased, and does not offer any warranty in the event that this product is used on public telecommunication lines in another country.

## Declaration of Conformity (Europe only) (DCP-J315W, DCP-J515W, DCP-J715W, MFC-J220, MFC-J265W, MFC-J410, MFC-J415W and MFC-J615W only)

---

We, Brother Industries, Ltd.

15-1, Naeshiro-cho, Mizuho-ku, Nagoya 467-8561 Japan

declare that this product is in compliance with the essential requirements of Directives 1999/5/EC and 2005/32/EC.

The Declaration of Conformity (DoC) is on our Website.

Please go to <http://solutions.brother.com/>

-> choose region (eg. Europe)

-> choose country

-> choose your model

-> choose "Manuals"

-> choose Declaration of Conformity (Select Language when required.)

## **Declaration of Conformity (Europe only) (DCP-J125 only)**

---

We, Brother Industries, Ltd.

15-1, Naeshiro-cho, Mizuho-ku, Nagoya 467-8561 Japan

declare that this product is in compliance with the essential requirements of Directives 2004/108/EC, 2006/95/EC and 2005/32/EC.

The Declaration of Conformity (DoC) is on our Website.

Please go to <http://solutions.brother.com/>

-> choose region (eg. Europe)

-> choose country

-> choose your model

-> choose "Manuals"

-> choose Declaration of Conformity (Select Language when required.)

## **Radio interference**

---

This product complies with EN55022 (CISPR Publication 22)/Class B. When connecting the machine to a computer, ensure that you use a USB cable which does not exceed 2 m in length.



## International ENERGY STAR® Qualification Statement

---

The purpose of the International ENERGY STAR® Program is to promote the development and popularization of energy-efficient office equipment.

As an ENERGY STAR® Partner, Brother Industries, Ltd. has determined that this product meets the ENERGY STAR® specifications for energy efficiency.



## EU Directive 2002/96/EC and EN50419

---



European  
Union Only

This equipment is marked with the above recycling symbol. It means that at the end of the life of the equipment you must dispose of it separately at an appropriate collection point and not place it in the normal domestic unsorted waste stream. This will benefit the environment for all.  
(European Union only)

# Regulatory Notices

## WARNING

DO NOT use this machine near water, for example, near a bath tub, wash bowl, kitchen sink or washing machine, in a wet basement or near a swimming pool.

---

Avoid using this machine during an electrical storm. There may be a remote risk of electric shock from lightning.

---

DO NOT use this machine to report a gas leak in the vicinity of the leak. (MFC only)

---

Use only the power cord supplied with this machine.

---

DO NOT use the machine if the power cord is frayed or damaged, doing so may cause a fire.

---

DO NOT allow anything to rest on the power cord.

---

DO NOT place this product where people can walk on the cord.

---

DO NOT pull on the middle of the AC power cord. Doing this might cause an electrical shock.

---

Wiring information (U.K. only)

If you need to replace the plug fuse, fit a fuse that is approved by ASTA to BS1362 with the same rating as the original fuse. Always replace the fuse cover. Never use a plug that does not have a cover. If in any doubt, call a qualified electrician.

Warning - This machine must be earthed.

The wires in the mains lead are coloured in line with the following code:

- Green and Yellow: Earth
  - Blue: Neutral
  - Brown: Live
-

## CAUTION

This product must be installed near an electrical socket that is easily accessible. In case of an emergency, you must unplug the power cord from the electrical socket to shut off the power completely. (IEC)

## IMPORTANT

**LAN connection (MFC-J615W and DCP-J715W only)**

DO NOT connect this machine to a LAN connection that is subject to over-voltages. (IEC)



### Note

Brother shall not be liable for any loss or damage that may arise from the use of the information contained herein (including, without limitation, any direct, special or consequential damages). Nothing contained herein shall affect any existing product warranty, or be construed as granting any additional product warranty.

# Trademarks

The Brother logo is a registered trademark of Brother Industries, Ltd.

Brother is a registered trademark of Brother Industries, Ltd.

Multi-Function Link is a registered trademark of Brother International Corporation.

Windows Vista is either a registered trademark or trademark of Microsoft Corporation in the United States and/or other countries.

Microsoft, Windows, Windows Server and Internet Explorer are registered trademarks of Microsoft Corporation in the United States and/or other countries.

Apple and Macintosh are trademarks of Apple Inc., registered in the United States and other countries.

Adobe, Flash, Illustrator, PageMaker and Photoshop are either registered trademarks or trademarks of Adobe Systems Incorporated in the United States and/or other countries.

Nuance, the Nuance logo, PaperPort and ScanSoft are trademarks or registered trademarks of Nuance Communications, Inc. or its affiliates in the United States and/or other countries.

PowerPC is a trademark of International Business Machines Corporation.

Memory Stick, Memory Stick PRO, Memory Stick PRO Duo, Memory Stick Duo, MagicGate Memory Stick, Memory Stick Micro and M2 are trademarks of Sony Corporation.

AOSS is a trademark of Buffalo Inc.

Wi-Fi, WPA, WPA2, Wi-Fi Protected Access and Wi-Fi Protected Setup are either trademarks or registered trademarks of Wi-Fi Alliance in the United States and/or other countries.

Intel and Pentium are trademarks of Intel Corporation in the U.S. and other countries.

AMD is a trademark of Advanced Micro Devices, Inc.

FaceFilter Studio is a trademark of Reallusion, Inc.

BRAdmin Professional is a trademark of Brother Industries, Ltd.

UNIX is a registered trademark of The Open Group.

Linux is the registered trademark of Linus Torvalds in the U.S. and other countries.

CorelDraw, Corel Paint Shop Pro and Corel WordPerfect are trademarks or registered trademarks of Corel Corporation and/or its subsidiaries in Canada, the United States and/or other countries.

Each company whose software title is mentioned in this manual has a Software License Agreement specific to its proprietary programs.

**Any trade names and product names of companies appearing on Brother products, related documents and any other materials are all trademarks or registered trademarks of those respective companies.**

# Open Source Licensing Remarks

This product includes open-source software.

Please see Open Source Licensing Remarks and Copyright information on the supplied CD-ROM.

(For Windows®) “X:\License.txt” (where X is your drive letter).

(For Macintosh) Double-click the CD-ROM icon on your desktop. Then double-click the **Utilities** icon. License.rtf will appear.

## Unlawful use of copying equipment

It is an offence to make reproductions of certain items or documents with the intent to commit fraud. We suggest you check with relevant legal authorities if in doubt about a particular item or document.

The following is a non-exhaustive list of documents which may not lawfully be copied:

- Currency
- Bonds or other certificates of indebtedness
- Certificates of Deposit
- Armed Forces Service or Draft papers
- Passports
- Postage Stamps (cancelled or uncanceled)
- Immigration Papers
- Welfare documents
- Cheques or Drafts drawn by Governmental Agencies
- Identification Documents, badges or insignias

Copyrighted works cannot be copied, subject to the “fair dealing” exception relating to sections of a copyrighted work. Multiple copies would indicate improper use.

Works of art should be considered the equivalent of copyrighted works.

Licenses and Certificates of Title to motor vehicles may not be copied under certain national laws.

**brother**®