





Please read the Product Safety Guide first, then read this Quick Setup Guide for the correct setup and installation procedure.

To view the Quick Setup Guide in other languages, please visit <http://solutions.brother.com/>.

 **Note**

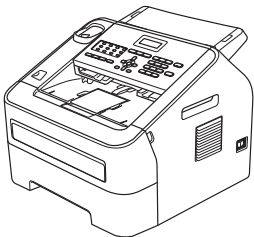
Most of the illustrations in this guide show the MFC-7290.

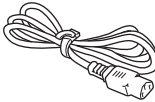
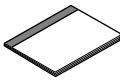
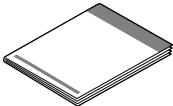
1 Unpack the machine and check the components

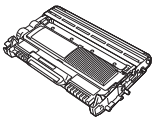
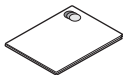
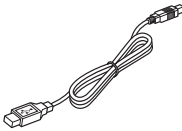
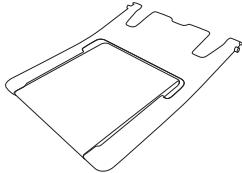
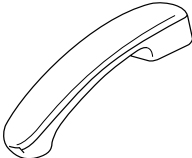
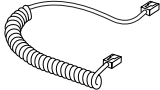
	 Installer CD-ROM		 AC Power Cord
	 Basic User's Guide	 Quick Setup Guide	 Telephone Line Cord
 Drum Unit and Toner Cartridge Assembly (pre-installed)	 Product Safety Guide	 USB Interface Cable	
 ADF Document Output Support	 Telephone Handset	 Curled Handset Cord	

⚠ WARNING	WARNING indicates a potentially hazardous situation which, if not avoided, could result in death or serious injuries.
⚠ CAUTION	CAUTION indicates a potentially hazardous situation which, if not avoided, may result in minor or moderate injuries.

⚠ WARNING

Plastic bags are used in the packing of your machine. To avoid danger of suffocation, keep these plastic bags away from babies and children. Plastic bags are not toys.

⚠ CAUTION

When moving the machine, grasp the side handholds firmly from the front of the machine.

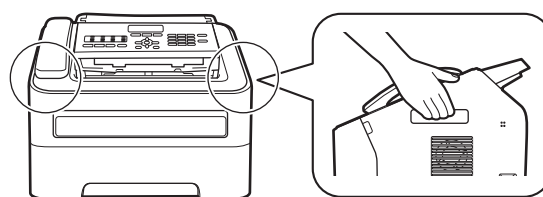

Note

- Keep a minimum gap around the machine as shown in the illustration.

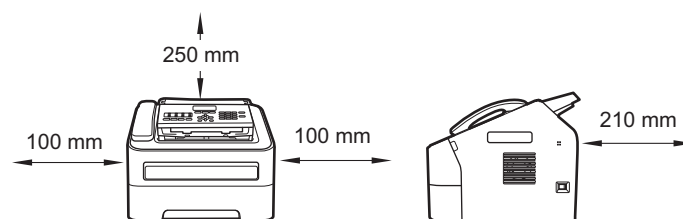

- The components included in the box may differ depending on your country.
- We recommend that you save the original packaging.
- If for any reason you must ship your machine, carefully repack the machine in the original packaging to avoid any damage during transit. The machine should be adequately insured with the carrier. For how to repack the machine, see *Packing and shipping the machine* in the *Advanced User's Guide*.
- To ensure safe operation the supplied plug must be inserted only into a standard power outlet that is properly grounded through the standard electrical wiring. Non grounded equipment may cause an electrical shock hazard, and may cause excessive electrical noise radiation.

USB cable

- It is recommended to use a USB 2.0 cable (Type A/B) that is no longer than 2 metres.

2 Remove the packing material from the machine

⚠ IMPORTANT

DO NOT connect the AC power cord yet.

- a Remove the packing tape from the outside of the machine.
- b Open the front cover.

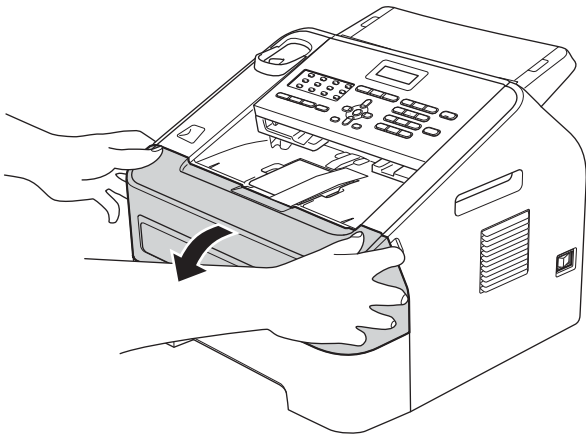

- c Remove the Silica Pack from the inside of the machine.

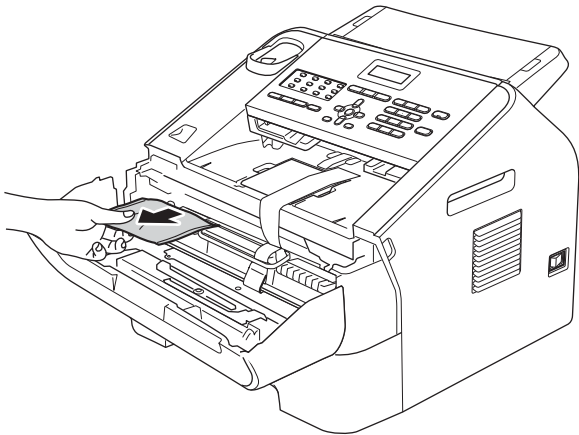

⚠ CAUTION

DO NOT eat the silica gel pack. Please throw away. If ingested, seek medical attention immediately.

- d Lift the elastic band off the drum.

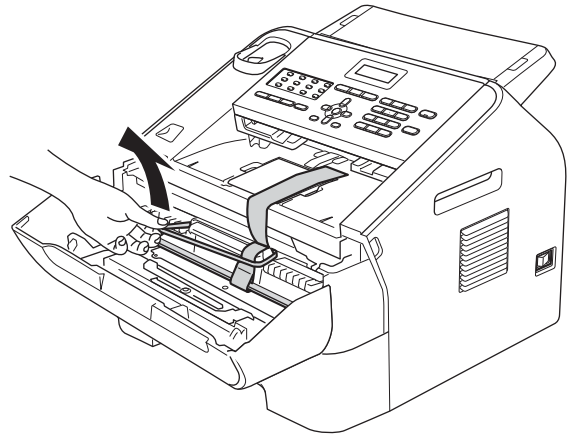

- e Pull the paper strip to remove the protective material as shown in the illustration.

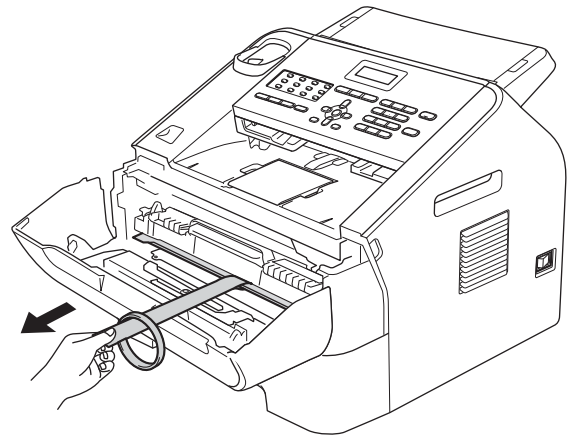

- f Take out the drum unit and toner cartridge assembly.

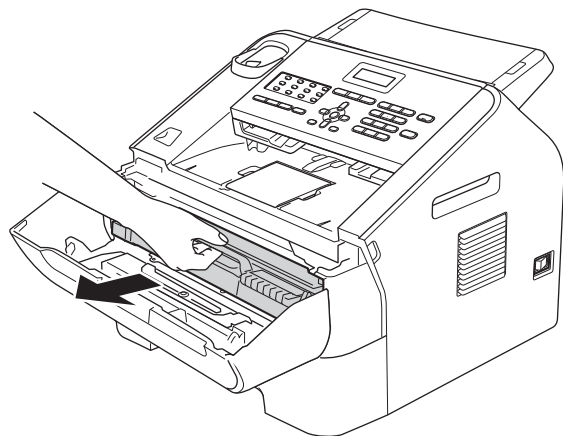

- g** Gently shake it from side to side several times to distribute the toner evenly inside the assembly.

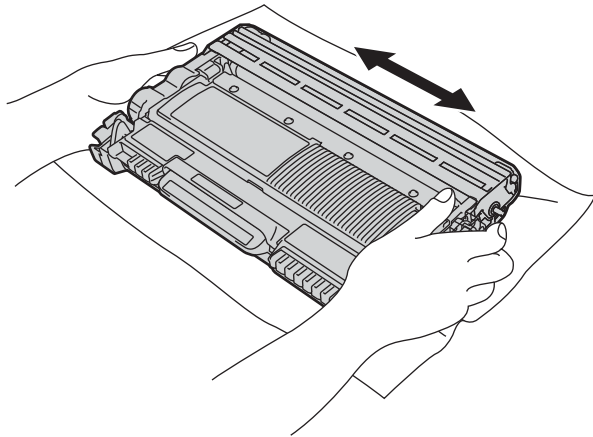

- h** Put the drum unit and toner cartridge assembly back in the machine.

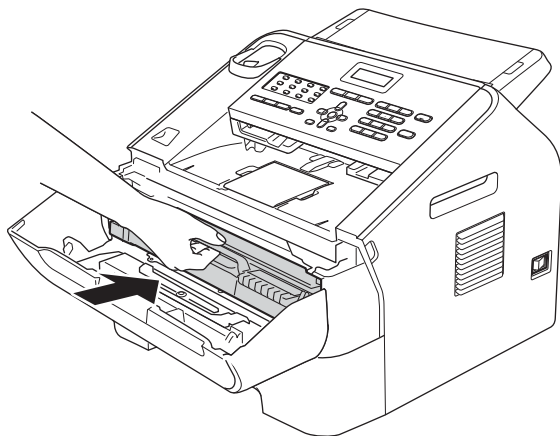

- i** Close the front cover of the machine.

3 Attach the ADF Document Output Support

- a** Unfold the ADF Document Support.

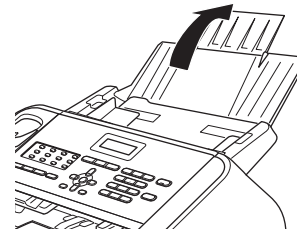

- b** Open the control panel cover by lifting it toward the back.

Control Panel Cover

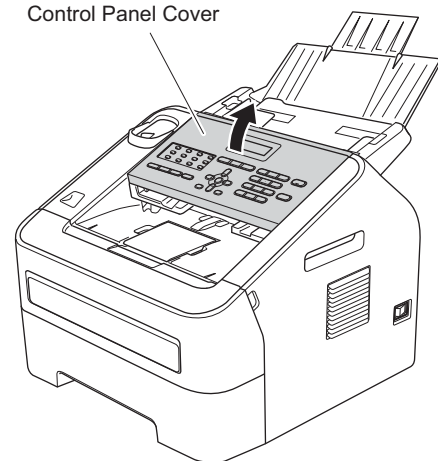

- c** Attach the ADF Document Output Support.

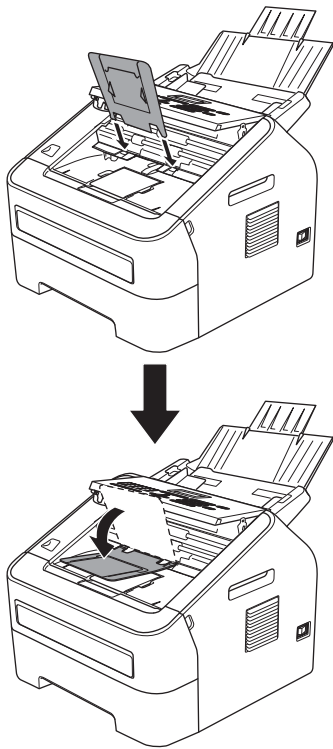

- d** Close the control panel cover.

4 Install the Handset

- a** Connect the curled handset cord to the machine and the other end to the handset.

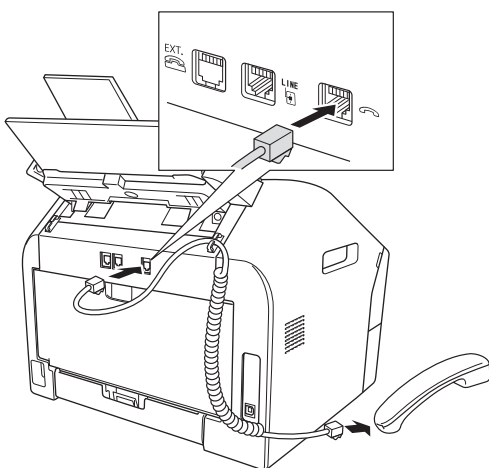

5 Load paper in the paper tray

- a** Pull the paper tray completely out of the machine.

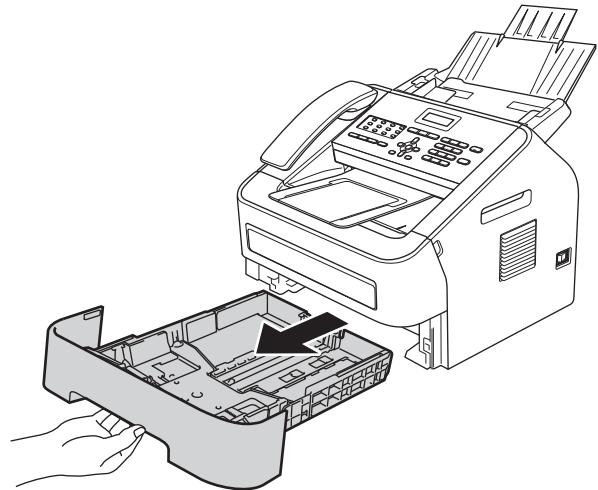

- b** While pressing the green paper-guide release lever ①, slide the paper guides to fit the paper size you are loading in the tray. Make sure that the guides are firmly in the slots.

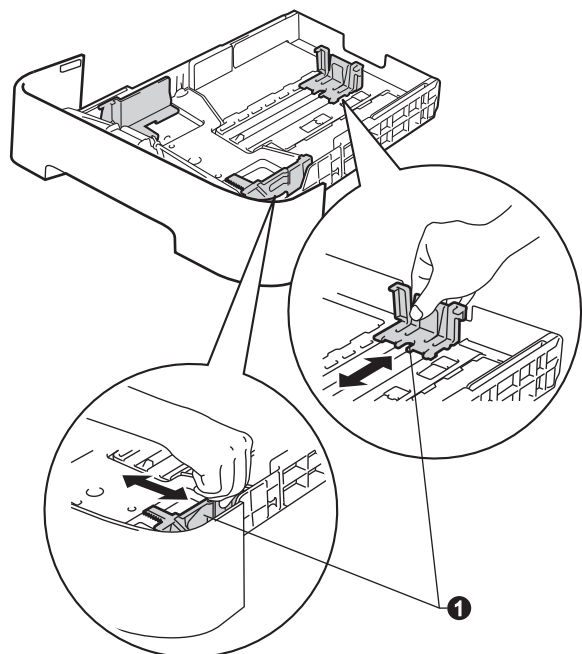

- c** Fan the stack of paper well to avoid paper jams and misfeeds.

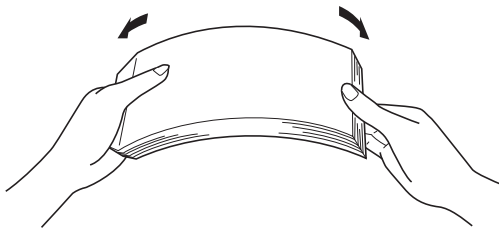

- d** Put paper in the tray and make sure:
- The paper is below the maximum paper mark (▼▼▼) ❶.
 - Over filling the paper tray will cause paper jams.
 - The side to be printed on must be face down.
 - The paper guides gently touch the sides of the paper so it will feed correctly.

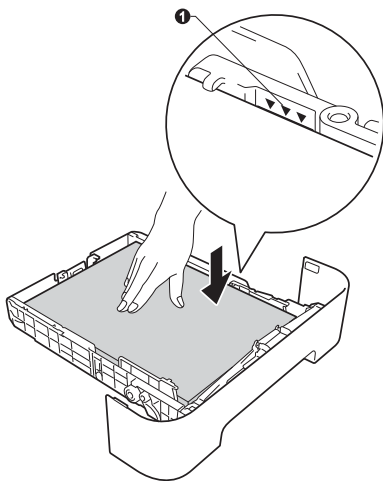

- e** Put the paper tray firmly back in the machine. Make sure that it is completely inserted into the machine.

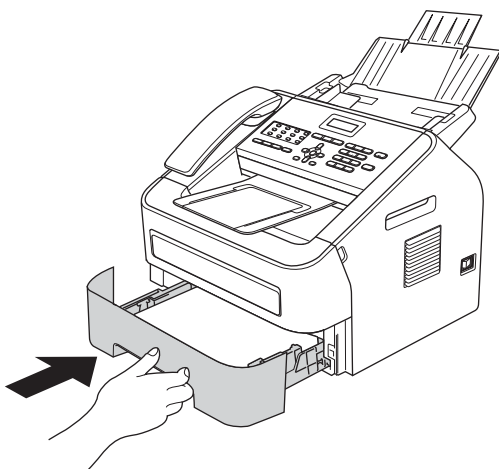

- f** Unfold the support flap ❶ to prevent paper from sliding off the face-down output tray.

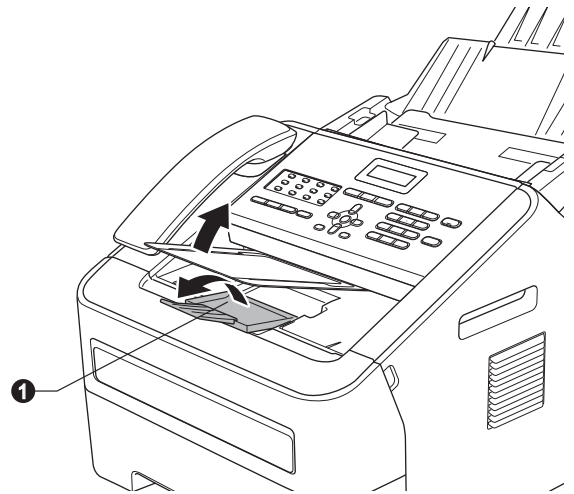

-  For more information about recommended paper, see *Recommended paper and print media* in the *Basic User's Guide*.

6 Connect the power cord and telephone line

- a** Connect the AC power cord to the machine, and then plug it into an electrical socket.
- b** Turn the machine's power switch on.

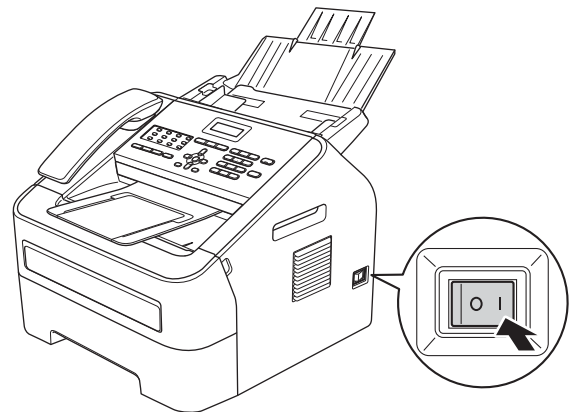

- C** Connect the telephone line cord. Connect one end of the telephone line cord to the socket on the machine marked **LINE** and the other end to a telephone wall socket.

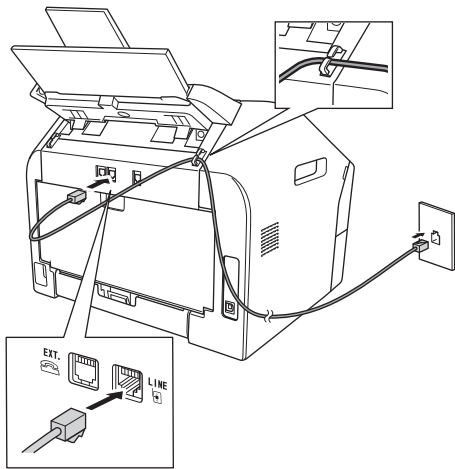

IMPORTANT

The telephone line cord **MUST** be connected to the socket on the machine marked **LINE**.

WARNING

The machine must be grounded using an earthed plug. Since the machine is grounded through the electrical socket, you can protect yourself from potentially hazardous electrical conditions on the telephone network by keeping the power cord connected to your machine when you connect it to a telephone line. Similarly, you can protect yourself when you want to move your machine by disconnecting the telephone line first and then the power cord.

Note

If you are sharing one telephone line with an external telephone, connect it as shown below. Before you connect the external telephone, remove the protective cap ③ from the **EXT.** socket on the machine.

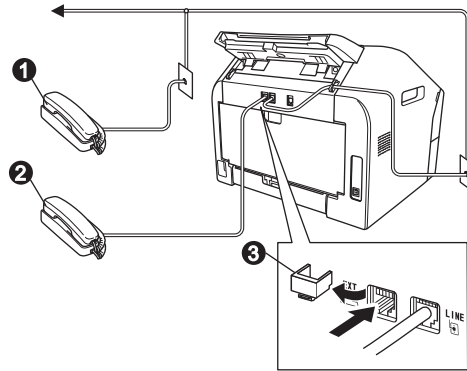

- ① Extension telephone
- ② External telephone
- ③ Protective cap

Note

If you are sharing one telephone line with an external telephone answering machine, connect it as shown below. Before you connect the external telephone answering machine, remove the protective cap ③ from the **EXT.** socket on the machine.

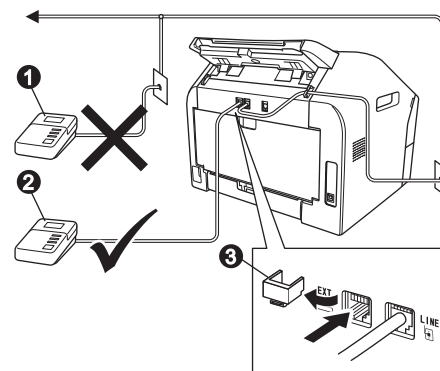

- ① Extension telephone answering machine (not allowed)
- ② External telephone answering machine
- ③ Protective cap

Set the receive mode to **External TAD** if you have an external answering machine. See *Connecting an external TAD* in the *Basic User's Guide*.

7 Choose your language (If needed)

- a** Press **Menu**, **0**, **0**.
- b** Press **▲** or **▼** to choose your language.
Press **OK**.
- c** Press **Stop/Exit**.

8 Set the LCD contrast (if needed)

If you are having difficulty reading the LCD, try changing the contrast setting.

- a** Press **Menu**, **1**, **5**.
- b** Press **▶** to increase the contrast.
—OR—
Press **◀** to decrease the contrast.
Press **OK**.
- c** Press **Stop/Exit**.

9 Set the date and time

The machine displays the time, and if you set up the station ID the date and time will be added to each fax you send.

- a** Press **Menu**, **0**, **1**.
- b** Enter the last two digits of the year on the dial pad, and then press **OK**.

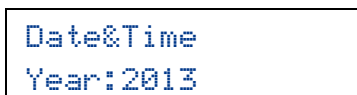

Date&Time
Year:2013

(e.g. Enter **1**, **3** for 2013.)

- c** Enter the two digits for the month on the dial pad, and then press **OK**.

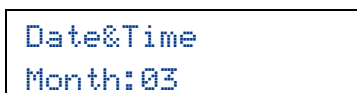

Date&Time
Month:03

(e.g. Enter **0**, **3** for March.)

- d** Enter the two digits for the day on the dial pad, and then press **OK**.

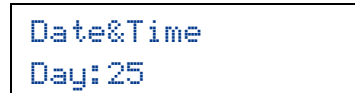

Date&Time
Day:25

(e.g. Enter **2**, **5** for 25th.)

- e** Enter the time in 24-hour format on the dial pad, and then press **OK**.

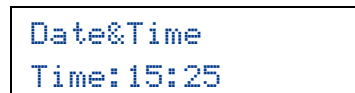

Date&Time
Time:15:25

(e.g. Enter **1**, **5**, **2**, **5** for 15:25.)

- f** Press **Stop/Exit**.

10 Enter personal information (Station ID)

The machine displays the date and time, and if you set up the Station ID, it will add it to each fax you send.

- a** Press **Menu**, **0**, **2**.
- b** Enter your fax number (up to 20 digits) on the dial pad, and then press **OK**.



Station ID
Fax:

- c** Enter your telephone number (up to 20 digits) on the dial pad, and then press **OK**. If your telephone number and fax number are the same, enter the same number again.



Station ID
Tel:

- d** Use the dial pad to enter your name (up to 10 characters for Chinese or 20 characters for alphanumeric), and then press **OK**.



Name:
Enter & OK Key ▲ 拼

Note

- You can register your name in Chinese or English in this machine, you can switch between the alphabet input mode and the Chinese-entry mode by pressing ▲ button, the current input mode will appear in the lower right corner of LCD. Simplified Chinese can be converted from Pinyin entry.
- See the following chart for entering your name.
- If you need to enter a character that is on the same key as the last character, press ► to move the cursor to the right.
- If you entered a character incorrectly and want to change it, press ◀ or ▶ to move the cursor to the incorrect character, press **Clear**.

Press key	One time	Two times	Three times	Four times	Five times	Six times	Seven times	Eight times	Nine times
2	a	b	c	A	B	C	2	a	b
3	d	e	f	D	E	F	3	d	e
4	g	h	i	G	H	I	4	g	h
5	j	k	l	J	K	L	5	j	k
6	m	n	o	M	N	O	6	m	n
7	p	q	r	s	P	Q	R	S	7
8	t	u	v	T	U	V	8	t	u
9	w	x	y	z	W	X	Y	Z	9

 For more details, see *Entering text* in the *Basic User's Guide*.

- e** Press **Stop/Exit**.

Note

If you make a mistake and want to start again, press **Stop/Exit** and go back to step **a**.

11 Fax Transmission Report

Your Brother machine is equipped with a Transmission Verification Report that can be used as confirmation that you sent a fax. This report lists the name or fax number of the receiving party, the date, time, and duration of the transmission, the number of pages transmitted, and whether or not the transmission was successful. If you want to use the Fax Transmission Report feature see *Printing reports* in the *Advanced User's Guide*.

12 Set tone or pulse dialling mode

Your machine comes set for a Tone dialling service. If you have a Pulse dialling service (rotary), you need to change the dialling mode.

- a** Press **Menu, 0, 3**.
- b** Press ▲ or ▼ to choose *Pulse (or Tone)*. Press **OK**.
- c** Press **Stop/Exit**.

13 Set the telephone line compatibility

If you are connecting the machine to a VoIP service (over the Internet) you need to change the compatibility setting.

Note

If you are using an analogue telephone line you can skip this step.

- a** Press **Menu, 2, 0, 1**.
- b** Press ▲ or ▼ to choose *Basic (for VoIP)*. Press **OK**.
- c** Press **Stop/Exit**.

14

Dial Prefix

The dial prefix setting will automatically dial a predefined number before every fax number you dial. For example: If your phone system requires a 9 to dial an outside number this setting will automatically dial 9 for every fax you send.

a Press **Menu**, **0**, **5**.

b Enter the prefix number (up to 5 digits) on the dial pad, and then press **OK**.



Note

- You can use the numbers 0 to 9, #, * and !. (Press **Hook/Hold** to display "!".)
- You cannot use ! with any other numbers or characters.
- If your telephone system requires a timed break recall (hookflash), press **Hook/Hold** to enter the break.
- If the pulse dialling mode is on, # and * are not available to use.

c Press **Stop/Exit**.

15 Choose your Operating System

These installation instructions are for Windows® XP Home/Windows® XP Professional, Windows® XP Professional x64 Edition, Windows Vista®, Windows® 7, and Mac OS X (versions 10.5.8, 10.6.x, 10.7.x).

Note

- You can visit us at <http://solutions.brother.com/> where you can get product support, the latest driver updates and utilities, and answers to frequently asked questions (FAQs) and technical questions.
- For Linux®, visit your model page at <http://solutions.brother.com/>.

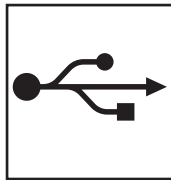
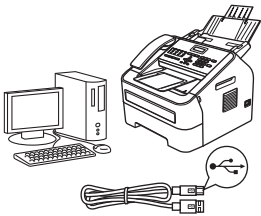

Windows®, go to page 12
Macintosh, go to page 14



For Windows® Users

(Windows® XP/XP Professional x64 Edition/Windows Vista®/Windows® 7)

16 Before you install

a Make sure that your computer is ON and you are logged on with Administrator rights.

IMPORTANT

- If there are any programs running, close them.
- The screens may differ depending on your operating system.

Note

(For MFC-7290)
 The installer CD-ROM includes Presto! PageManager. This software supports Windows® XP, XP Professional x64 Edition, Windows Vista® and Windows® 7. Update to the latest Windows® Service Pack before installing MFL-Pro Suite.

b Turn off the machine.

Note

If the USB cable is connected to your computer before the installation, the dialog box will automatically appear to inform that your computer found new hardware. Please cancel it to close the screen.

17 Install MFL-Pro Suite

a Put the installer CD-ROM into your CD-ROM drive. If the model name screen appears, choose your machine. If the language screen appears, choose your language.

Note

If the Brother screen does not appear automatically, go to **My Computer (Computer)**, double-click the CD-ROM icon, and then double-click **start.exe**.

b Click **Install MFL-Pro Suite**, and click **Yes** if you accept the license agreements.

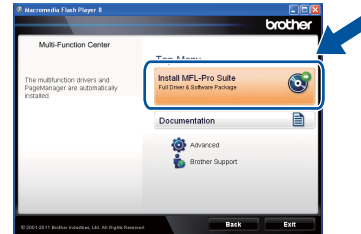

Note

- If the installation does not continue automatically, open the top menu again by ejecting and then reinserting the CD-ROM or double-click the **start.exe** program from the root folder, and continue from step **b** to install MFL-Pro Suite.
- For Windows Vista® and Windows® 7 users, when the **User Account Control** screen appears, click **Allow** or **Yes**.

c Choose **Standard** and then click **Next**.

d Follow the on-screen instructions until this screen appears.



e Connect the USB cable to the USB port marked with the  symbol on your machine and then connect the cable to your computer.

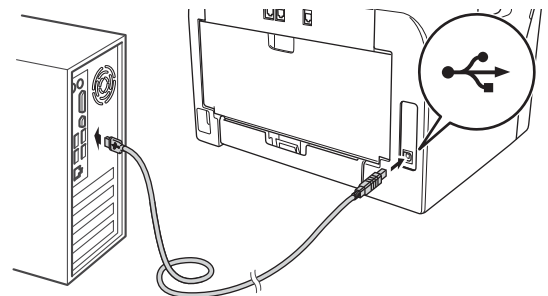

f Turn the machine on.
The installation will automatically start. Follow the on-screen instructions.



! IMPORTANT

DO NOT cancel any of the screens during the installation. It may take a few seconds for all screens to appear.

Note

For Windows Vista® and Windows® 7 users, when the **Windows Security** screen appears, select the check box and click **Install** to complete the installation correctly.

g When the **Setup Complete** screen appears, check the box of the action you want to perform, and then click **Next**.

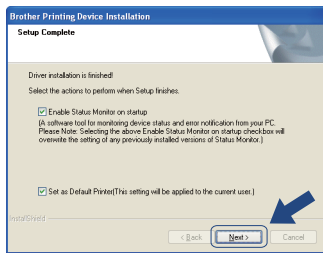

18 Finish and restart

a Click **Finish** to restart your computer. After restarting the computer, you must be logged on with Administrator rights.

Note

- If an error message appears during the software installation, run the **Installation Diagnostics** located in **Start/All Programs/Brother/MFC-XXXX** (where MFC-XXXX is your model name).
- Depending on your security settings, a Windows® Security or antivirus software window may appear when using the machine or its software. Please allow or permit the window to continue.

Finish

The installation is now complete.

Note

XML Paper Specification Printer Driver

The XML Paper Specification Printer Driver is the most suitable driver for Windows Vista® and Windows® 7 when printing from applications that use the XML Paper Specification documents. Please download the latest driver by accessing the Brother Solutions Center at <http://solutions.brother.com/>.



For Macintosh Users (Mac OS X 10.5.8 - 10.7.x)

16 Before you install

- a** Make sure your machine is connected to the power and your Macintosh is ON. You must be logged on with Administrator rights.

IMPORTANT

For users of Mac OS X 10.5.7 or lower, upgrade to Mac OS X 10.5.8 - 10.7.x. (For the latest drivers and information for the Mac OS X you are using, visit <http://solutions.brother.com/>.)

- b** Connect the USB cable to the USB port marked with the  symbol on your machine and then connect the cable to your Macintosh.

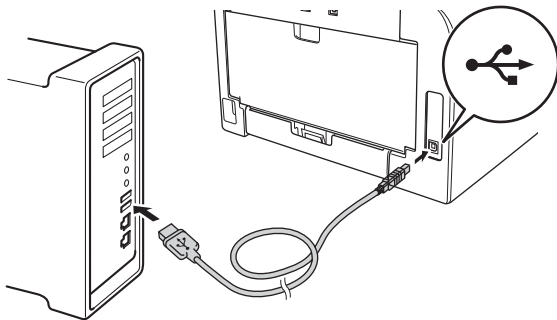

- c** Make sure your machine's power switch is on.

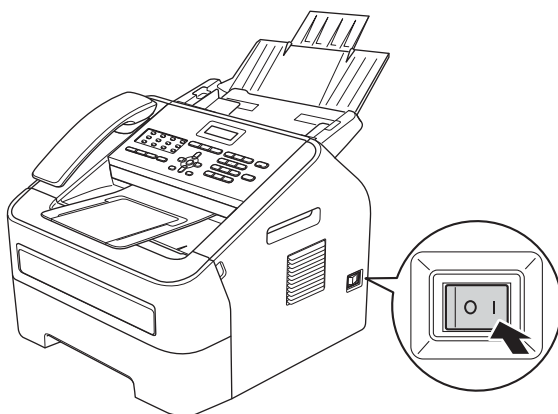

17 Install MFL-Pro Suite

- a** Put the installer CD-ROM into your CD-ROM drive.
- b** Double-click the **Start Here OSX** icon. If prompted, select your model and then follow the on-screen instructions.



IMPORTANT

DO NOT cancel any of the screens during the installation. It may take a few minutes for the installation to complete.

- c** Choose your machine from the list, and then click **OK**.

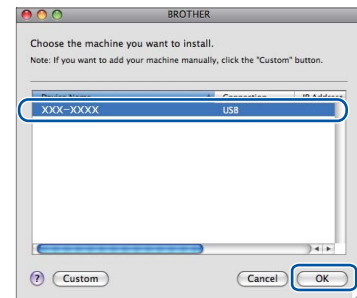

- d** When this screen appears, click **Next**.

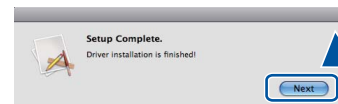

- OK!** The installation of MFL-Pro Suite is now complete. Go to step 18 on page 15.



18 Download and install Presto! PageManager (For MFC-7290)

When Presto! PageManager is installed OCR capability is added to Brother ControlCenter2. You can easily scan, share and organize photos and documents using Presto! PageManager.

- a** On the **Brother Support** screen, click **Presto! PageManager** and follow the on-screen instructions.

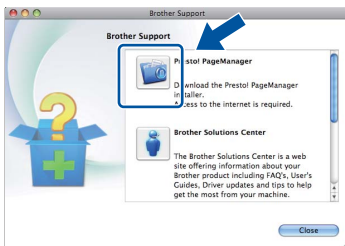

Finish

The installation is now complete.

Brother CreativeCenter



Get inspired. If you're using Windows®, double-click the Brother CreativeCenter icon on your desktop to access our FREE web site with many ideas and resources for personal and professional use. This icon appears after installing MFL-Pro Suite or the optional software available from the Brother Solutions Center.



Mac users can access Brother CreativeCenter at this web address:

<http://www.brother.com/creativecenter/>

Consumables

When the time comes to replace consumable items, an error will be indicated by the LCD on the control panel. For more information about the consumables for your machine, visit us at <http://www.brother.com/original/> (click "Asia/Oceania", and then click "China") or contact your local Brother reseller.

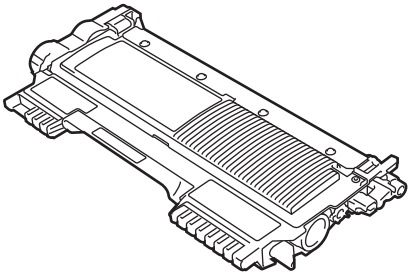
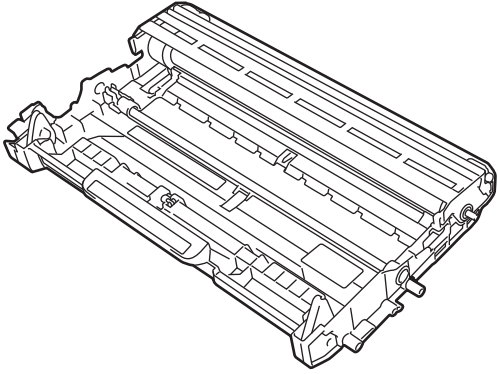
Toner cartridges	Drum unit
Standard Toner: TN-2215 High Yield Toner: TN-2225	DR-2250
	

Trademarks

The Brother logo is a registered trademark of Brother Industries, Ltd.

Brother is a registered trademark of Brother Industries, Ltd.

Microsoft and Windows are registered trademarks of Microsoft Corporation in the United States and/or other countries.

Windows Vista is either a registered trademark or trademark of Microsoft Corporation in the United States and/or other countries.

Apple, Macintosh, and Mac OS are trademarks of Apple Inc., registered in the U.S. and other countries.

Mac and the Mac logo are trademarks of Apple Inc., registered in the U.S. and other countries.

Linux is the registered trademark of Linus Torvalds in the U.S. and other countries.

Each company whose software title is mentioned in this manual has a Software License Agreement specific to its proprietary programs.

Any trade names and product names of companies appearing on Brother products, related documents and any other materials are all trademarks or registered trademarks of those respective companies.

Compilation and Publication

Under the supervision of Brother Industries, Ltd., this manual has been compiled and published, covering the latest product descriptions and specifications.

The contents of this manual and the specifications of this product are subject to change without notice.

Brother reserves the right to make changes without notice in the specifications and materials contained herein and shall not be responsible for any damages (including consequential) caused by reliance on the materials presented, including but not limited to typographical and other errors relating to the publication.

Copyright and License

©2012 Brother Industries, Ltd. All rights reserved.