

brother

Advanced User's Guide

DCP-T300
DCP-T500W
DCP-T700W
MFC-T800W

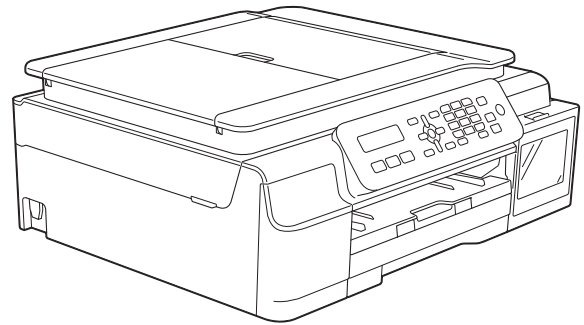

Version 0

CHN-ENG

User's Guides and where do I find them?

Which Guide?	What's in it?	Where is it?
Product Safety Guide	Read this Guide first. Please read the Safety Instructions before you set up your machine. See this Guide for trademarks and legal limitations.	Printed / In the box
Quick Setup Guide	Follow the instructions for setting up your machine and installing the drivers and software for the operating system and connection type you are using.	Printed / In the box
Basic User's Guide	Learn the basic Fax (MFC-T800W), Copy and Scan operations, and how to replace consumables. See troubleshooting tips.	PDF file / CD-ROM (Windows®) / Brother Solutions Center ² (Macintosh)
Advanced User's Guide	Learn more advanced operations: Fax (MFC-T800W), Copy, security features (MFC-T800W), printing reports, and performing routine maintenance.	PDF file / CD-ROM (Windows®) / Brother Solutions Center ² (Macintosh)
Software and Network User's Guide ¹	This Guide provides instructions for Scanning, Printing, PC-Fax (MFC-T800W) and other operations that can be performed by connecting your Brother machine to a computer. You can also find useful information about using the Brother ControlCenter utility, using your machine in a network environment, and frequently used terms.	HTML / CD-ROM (Windows®) / Brother Solutions Center ² (Macintosh)
Google Cloud Print Guide ³	This Guide provides details on how to use Google Cloud Print™ services for printing over the Internet.	PDF file / Brother Solutions Center ²
Mobile Print/Scan Guide for Brother iPrint&Scan ³	This Guide provides useful information about printing from your mobile device and scanning from your Brother machine to your mobile device when connected to a Wi-Fi® network.	PDF file / Brother Solutions Center ²

¹ Network features are not supported by the DCP-T300.

² Visit us at www.95105369.com.

³ DCP-T500W, DCP-T700W and MFC-T800W only.

Table of Contents

1	General setup	1
	IMPORTANT NOTE.....	1
	Memory Storage	1
	Sleep Mode	1
	LCD	2
	LCD Contrast.....	2
	Mode Timer (MFC models only)	2
2	Security features (MFC models only)	3
	TX Lock	3
	Setting and changing the TX Lock password	3
	Turning TX Lock on/off	4
3	Sending a fax (MFC models only)	5
	Additional sending options.....	5
	Sending faxes using multiple settings	5
	Stop faxing.....	5
	Contrast	5
	Changing the fax resolution.....	5
	Additional sending operations.....	6
	Sending a fax manually	6
	Sending a fax at the end of a conversation	7
	Broadcasting.....	7
	Real Time Transmission.....	8
	Overseas Mode	9
	Checking and cancelling waiting jobs	9
4	Receiving a fax (MFC models only)	10
	Memory Receive.....	10
	Printing a fax from the memory	10
	PC-Fax Receive (Windows®)	10
	Turning off Memory Receive operation	11
	Changing Memory Receive operations	11
	Additional receiving operations.....	12
	Out of Paper Reception	12
	Printing a reduced incoming fax	12
	Receiving a fax at the end of a conversation.....	12

5	Dialling and storing numbers (MFC models only)	13
	Additional dialling operations	13
	Combining Speed Dial numbers	13
	Additional ways to store numbers	14
	Setting up Groups for Broadcasting	14
	Changing or deleting a Group	14
6	Printing reports	16
	Fax reports (MFC models only)	16
	Transmission Verification Report	16
	Fax Journal (activity report)	16
	Reports	17
	How to print a report	17
7	Making copies	18
	Copy options	18
	Stop copying	18
	Changing copy speed and quality	18
	Enlarging or reducing copies	19
	Making N in 1 copies or a poster (Page Layout)	20
	2 in 1 ID copy (Page Layout)	21
	Sorting copies	22
	Adjusting Density	23
	Remove Background Color	23
A	Routine maintenance	24
	Cleaning and checking the machine	24
	Cleaning the outside of the machine	24
	Cleaning the machine's printer platen	25
	Cleaning the paper feed rollers	26
	Cleaning the paper pick-up rollers	27
	Packing and shipping the machine	28
B	Glossary	30
C	Index	33

IMPORTANT NOTE

- Most of the illustrations in this User's Guide show the MFC-T800W.

Memory Storage

Even if there is a power failure, you will not lose your menu settings because they are stored permanently. Temporary settings (such as Contrast, Overseas mode, and so on) will be lost. You may have to reset the date and time.

Sleep Mode

You can choose how long the machine will remain idle before it goes into Sleep Mode (up to 60 minutes). The timer will restart if any operation is carried out on the machine.

(MFC-T800W)

- 1 Press **Menu**, **2**, **6**.
- 2 Press **▲** or **▼** to choose 1 Min, 2 Mins, 3 Mins, 5 Mins, 10 Mins, 30 Mins or 60 Mins.
Press **OK**.
- 3 Press **Stop/Exit**.

(DCP-T300, DCP-T500W and DCP-T700W)

- 1 Press **Menu**.
- 2 Press **▲** or **▼** to choose 0.Initial Setup.
Press **OK**.
- 3 Press **▲** or **▼** to choose 3.Sleep Mode.
Press **OK**.
- 4 Press **▲** or **▼** to choose 1 Min, 2 Mins, 3 Mins, 5 Mins, 10 Mins, 30 Mins or 60 Mins, which is the length of time the machine is idle before entering Sleep Mode.
Press **OK**.
- 5 Press **Stop/Exit**.

LCD

LCD Contrast

If you are having difficulty reading the LCD, try changing the contrast setting.

(MFC-T800W)

- 1 Press **Menu**, **2**, **5**.
- 2 Press **▲** or **▼** to choose *Light* or *Dark*. Press **OK**.
- 3 Press **Stop/Exit**.

(DCP-T300, DCP-T500W and DCP-T700W)

- 1 Press **Menu**.
- 2 Press **▲** or **▼** to choose *0.Initial Setup*. Press **OK**.
- 3 Press **▲** or **▼** to choose *2.LCD Contrast*. Press **OK**.
- 4 Press **▲** or **▼** to choose *Light* or *Dark*. Press **OK**.
- 5 Press **Stop/Exit**.

Mode Timer (MFC models only)

The machine's control panel has three temporary mode keys: **FAX**, **SCAN** and **COPY**. You can change the amount of time the machine takes after the last **SCAN** or **COPY** operation before it returns to **FAX** mode. If you choose *Off*, the machine stays in the mode you used last.



- 1 Press **Menu**, **2**, **1**.
- 2 Press **▲** or **▼** to choose *0 Sec*, *30 Secs*, *1 Min*, *2 Mins*, *5 Mins* or *Off*. Press **OK**.
- 3 Press **Stop/Exit**.

Security features (MFC models only)

TX Lock

TX Lock lets you prevent unauthorized access to the machine.

While TX Lock is On, the following operations are available:

- Receiving faxes
- PC-Fax Receive ¹
(If PC-Fax Receive was already On)

¹ While the TX Lock feature is turned on, your machine will receive faxes and store them in its memory. Then, when TX Lock is turned off, the faxes will be sent to your chosen PC.

While TX Lock is On, the following operations are NOT available:

- Operation from the control panel
- PC printing

NOTE

If you forget the TX Lock password, contact Brother customer service for support.

Setting and changing the TX Lock password

NOTE

If you have already set the password, you will not need to set it again.

Setting the password

Make a careful note of your password.

- 1 Press **Menu**, **3**, **0**, **1**.
- 2 Enter a four-digit number for the password.
Press **OK**.
- 3 When the LCD shows `Verify:`, re-enter the password.
Press **OK**.
- 4 Press **Stop/Exit**.

Changing the password

- 1 Press **Menu**, **3**, **0**, **1**.
- 2 Press **▲** or **▼** to choose `Set Password`.
Press **OK**.
- 3 Enter a four-digit number for the old password.
Press **OK**.
- 4 Enter a four-digit number for a new password.
Press **OK**.
- 5 When the LCD shows `Verify:`, re-enter the password.
Press **OK**.
- 6 Press **Stop/Exit**.

Turning TX Lock on/off

Turning TX Lock on

- 1 Press **Menu**, **3**, **0**, **1**.
- 2 Press **▲** or **▼** to choose `Set TX Lock`. Press **OK**.
- 3 Enter the registered four-digit password. Press **OK**.
The machine goes offline and the LCD shows `TX Lock Mode`.

Turning TX Lock off

- 1 Press **Menu**.
- 2 Enter the registered four-digit password. Press **OK**.
TX Lock is turned off.

NOTE

If you enter the wrong password, the screen shows `Wrong Password` and stays offline. The machine will stay in `TX Lock Mode` until the registered password is entered.

3

Sending a fax (MFC models only)

Additional sending options

Sending faxes using multiple settings

When you send a fax, you can choose a combination of settings, such as Fax Resolution, Contrast, Overseas Mode, and Real Time TX.

- 1 Load your document.
- 2 Press  (FAX).
- 3 Choose a setting you want to change in the Setup Send menu (Menu, 3, 2). Press **OK**.
- 4 Choose the option you want for the setting. Press **OK**.
- 5 Do one of the following:
 - Press **1** to change another setting.
 - Press **2** when you have finished changing your settings. Go to step 6.
- 6 Enter the fax number.
- 7 Press **Mono Start**.

NOTE

Some settings are temporary and the machine returns to its default settings after you send a fax.

Stop faxing

To stop faxing, press **Stop/Exit**.

Contrast

If your document is very light or very dark, you may want to change the contrast. For most documents, the factory setting **Auto** can be used. **Auto** chooses the suitable contrast for your document.

Choose **Light** when sending a light document. Choose **Dark** when sending a dark document.

- 1 Load your document.
- 2 Press  (FAX).
- 3 Press **Menu, 3, 2, 2**.
- 4 Press **▲** or **▼** to choose **Auto**, **Light** or **Dark**. Press **OK**.
- 5 Press **2** so you can continue sending your fax.
- 6 Enter the fax number.
- 7 Press **Mono Start**.

NOTE

Even if you choose **Light** or **Dark**, the machine will send the fax using the **Auto** setting when you choose **Photo** as the Fax Resolution.

Changing the fax resolution

The quality of a fax can be improved by changing the fax resolution. Resolution can be changed for the next fax or for all faxes.

To change the fax resolution for the next fax

- 1 Load your document.
- 2 Press  (FAX).

- 3 Press **Fax Auto/Manual** then ▲ or ▼ to choose the resolution. Press **OK**.
- 4 Enter the fax number.
- 5 Press **Mono Start**.

To change the default fax resolution

- 1 Load your document.
- 2 Press  (**FAX**).
- 3 Press **Menu**, **3**, **2**, **1**.
- 4 Press ▲ or ▼ to choose the resolution you want. Press **OK**.
- 5 Press **2** so you can continue sending your fax.
- 6 Enter the fax number.
- 7 Press **Mono Start**.

NOTE

You can choose four different resolution settings for faxes.

Options	
Standard	Suitable for most typed documents.
Fine	Good for small print and transmits a little slower than Standard resolution.
S.Fine	Good for small print or artwork and transmits slower than Fine resolution.
Photo	Use when the document has varying shades of grey or is a photograph. Photo has the slowest transmission.

Additional sending operations

Sending a fax manually

Manual transmission lets you hear the dialling, ringing and fax-receiving tones while sending a fax.

NOTE

To send a multi-page fax, use the ADF.

- 1 Load your document.
- 2 Press  (**FAX**).
- 3 To listen for a dial tone, press **Hook**.
- 4 Dial the fax number.
- 5 When you hear the fax tones, press **Mono Start**. Press **1** when you select the **Fax Mode** to **Advanced Mode** and send the fax from the scanner glass.

Sending a fax at the end of a conversation

At the end of a conversation, you can send a fax to the other party before you both hang up.

- 1 Ask the other party to wait for fax tones (beeps) and then to press the Start or Send key before hanging up.
- 2 Load your document.
- 3 Press  (FAX).
- 4 Press **Mono Start**.
 - If you are using the scanner glass, press **1** to send a fax.

(When you select the Fax Mode to Advanced Mode)
- 5 Replace the handset of the external phone.

Broadcasting

Broadcasting is automatically sending the same fax message to more than one fax number. You can include Groups, Speed Dial numbers, and up to 50 manually dialed numbers in the same broadcast.

After the broadcast is finished, a Broadcast Report will be printed.

Before you begin the broadcast

Speed Dial numbers must be stored in the machine's memory before they can be used in a broadcast. (See Basic User's Guide: *Storing Speed Dial numbers.*)

Group numbers must also be stored in the machine's memory before they can be used in a broadcast. Group numbers include many stored Speed Dial numbers for easier dialling. (See *Setting up Groups for Broadcasting* on page 14.)

How to broadcast a fax

- 1 Load your document.
- 2 Press  (FAX).
- 3 Enter a number.
Press **OK**.
You can use either a Speed Dial, a Group or a manually entered number using the dial pad.
- 4 Repeat step 3 until you have entered all the fax numbers to be included in the broadcast.

5 Press **Mono Start**.

Faxing from the ADF

- The machine starts scanning the document.

Faxing from the scanner glass

When the LCD asks you `Next Page?`, do one of the following:

- To send a single page, press **2** (or press **Mono Start** again).

The machine starts sending the document.

- To send more than one page, press **1** and place the next page on the scanner glass.

Press **OK**.

The machine starts scanning the page. (Repeat this step for each page.)

After all the pages have been scanned, press **2** or **Mono Start** to begin faxing.

NOTE

- If you did not use up any of the numbers for Groups, you can “broadcast” faxes to as many as 90 different numbers.
- The machine’s available memory will vary depending on the types of jobs in the memory and the numbers used for broadcasting.
- If the `Out of Memory` message appears, press **Stop/Exit** to cancel or **Mono Start** to send the pages scanned so far.

Cancelling a Broadcast in progress

- 1 Press **Menu, 3, 5**.
The LCD will show the fax number or name being dialled and the Broadcasting job number.
- 2 Press **▲** or **▼** to choose the Broadcasting job number.
- 3 Press **OK**.
The LCD will ask you the following question:

1.Clear 2.Exit
- 4 To cancel the broadcast, press **1**.
- 5 Press **Stop/Exit**.

Real Time Transmission

When you are sending a fax, the machine will scan the documents into the memory before sending. Then, as soon as the telephone line is free, the machine will start dialling and sending.

Sometimes, you may want to send an important document immediately, without waiting for the machine to scan it into memory. You can set `Real Time TX` to `On` for all documents or `Next Fax Only` for the next fax only.

Sending in real time for all faxes

- 1 Press  (**FAX**).
- 2 Press **Menu, 3, 2, 3**.
- 3 Press **▲** or **▼** to choose `On` (or `Off`). Press **OK**.
- 4 Press **2** so you can continue sending your fax.
- 5 Load your document.
- 6 Enter the fax number.
- 7 Press **Mono Start**.

Sending in real time for the next fax only

- 1 Press  (FAX).
- 2 Press **Menu**, **3**, **2**, **3**.
- 3 Press **▲** or **▼** to choose `Next Fax Only`. Press **OK**.
- 4 Press **▲** or **▼** to choose `Next Fax:Off` or `Next Fax:On`.
- 5 Press **OK**.
- 6 Press **2** so you can continue sending your fax.
- 7 Load your document.
- 8 Enter the fax number.
- 9 Press **Mono Start**.

NOTE

- If the memory is full and you are sending a fax from the ADF, the machine will send the document in real time (even if `Real Time TX` is set to `Off`).
- In Real Time Transmission, the automatic redial feature does not work when you are using the scanner glass.
- If the memory is full, faxes from the scanner glass cannot be sent until you clear some of the memory.

Overseas Mode

If you are having difficulty sending a fax overseas due to possible interference on the telephone line, we recommend that you turn on Overseas Mode. After you send a fax using this feature, the feature will automatically turn itself off.

- 1 Load your document.
- 2 Press  (FAX).
- 3 Press **Menu**, **3**, **2**, **4**.
- 4 Press **▲** or **▼** to choose `On` (or `Off`). Press **OK**.
- 5 Press **2** so you can continue sending your fax.
- 6 Enter the fax number.
- 7 Press **Mono Start**.

Checking and cancelling waiting jobs

You can check which jobs are still waiting in the memory to be sent, or cancel a job. (If there are no jobs, the LCD shows `No Jobs Waiting`.)

- 1 Press **Menu**, **3**, **5**.
Any waiting jobs appear on the LCD.
- 2 Press **▲** or **▼** to scroll through the jobs and choose the job you want to cancel. Press **OK**.
- 3 Do one of the following:
 - Press **1** to cancel it.
 - Press **2** to exit without cancelling.
- 4 Repeat steps 2 and 3 for each job you want to cancel.
- 5 When you have finished, press **Stop/Exit**.

4

Receiving a fax (MFC models only)

Memory Receive

Memory Receive lets you receive faxes while you are away from the machine.

You can only use one Memory Receive operation at a time:

- PC-Fax Receive
- Off

You can change your selection at any time. If received faxes are still in the machine's memory when you change the Memory Receive operation, a message will appear on the LCD. (See *Changing Memory Receive operations* on page 11.)

Printing a fax from the memory

If you have chosen PC-Fax Receive, your machine will receive and store your faxes in its memory when your PC is turned off. To print faxes from the memory, follow the instructions.

- 1 Press **Menu**, **3**, **4**.
- 2 Press **Mono Start**.
- 3 Press **Stop/Exit**.

NOTE

When you print a fax from the memory, the fax data will be erased from your machine.

PC-Fax Receive (Windows®)

If you turn on the PC-Fax Receive feature, your machine will store received faxes in the memory and send them to your PC. You can then use your PC to view and store these faxes.

Even if you have turned off your PC (for example, at night or at the weekend), your machine will receive and store your faxes in its memory.

When you start your PC and the PC-FAX Receiving software runs, your machine transfers the faxes to your PC.

To transfer the received faxes to your PC you must have the PC-FAX Receiving software running on your PC.

(See *Software and Network User's Guide*.)

If you choose `Backup Print:On`, the machine will also print the fax.

- 1 Press  (**FAX**).
- 2 Press **Menu**, **3**, **1**, **6**.
- 3 Press **▲** or **▼** to choose `PC Fax Receive`. Press **OK**.
- 4 Press **▲** or **▼** to choose `<USB>` or the name of the PC you want to receive faxes if you are on a network. Press **OK**.
- 5 Press **▲** or **▼** to choose `Backup Print:On` or `Backup Print:Off`. Press **OK**.
- 6 Press **Stop/Exit**.

NOTE

- PC-Fax Receive is not supported by Mac OS.
- Before you can set up PC-Fax Receive, you must install the MFL-Pro Suite software on your PC. Make sure your PC is connected and turned on.

(See Software and Network User's Guide.)

- If you get an error message and the machine cannot print the faxes in the memory, you can use this setting to transfer your faxes to your PC. (See Basic User's Guide: *Transferring your faxes or Fax Journal report.*)

Turning off Memory Receive operation

- 1 Press  (FAX).
- 2 Press **Menu, 3, 1, 6**.
- 3 Press **▲** or **▼** to choose *Off*. Press **OK**.
- 4 Press **Stop/Exit**.

NOTE

The LCD will show you more options if there are still received faxes in the machine's memory. (See *Changing Memory Receive operations* on page 11.)

Changing Memory Receive operations

If there are received faxes in your machine's memory when you change the Memory Receive operation, the LCD will ask you one of the following questions:

If all the received faxes have already been printed

- Erase All Doc?
 - If you press **1** (Yes), faxes in the memory will be erased before the setting changes.
 - If you press **2** (No), faxes in the memory will not be erased and the setting will be unchanged.

If unprinted faxes remain in the memory

- Print All Fax?
 - If you press **1** (Yes), faxes in the memory will be printed before the setting changes. If a backup copy has already been printed, it will not be printed again.
 - If you press **2** (No), faxes in the memory will not be printed and the setting will be unchanged.

The LCD will ask you the following question:

- Send Fax to PC?
 - If you press **1** (Yes), faxes in the memory will be sent to your PC before the setting changes. You will be asked if you want to turn on Backup Print. (For more information, see *PC-Fax Receive (Windows®)* on page 10.)
 - If you press **2** (No), faxes in the memory will not be erased or transferred to your PC and the setting will be unchanged.

Additional receiving operations

Out of Paper Reception

As soon as the paper tray becomes empty during fax reception, the LCD shows `No Paper Fed`. Put some paper in the paper tray. (See Basic User's Guide: *Loading paper and other print media*.)

If you don't put paper in the paper tray, the machine will continue receiving the fax. The remaining pages will be stored in the memory, if enough memory is available.

Further incoming faxes will also be stored in memory until the memory is full. To print the faxes, put fresh paper in the tray. When the memory is full, the machine will stop answering calls.

Printing a reduced incoming fax

If you choose `On`, the machine reduces each page of an incoming fax to fit on one sheet of A4 or Letter size paper. The machine calculates the reduction ratio by using the page size of the fax and your Paper Size setting.

(See Basic User's Guide: *Paper Size*.)

- 1 Press  (FAX).
- 2 Press **Menu**, **3**, **1**, **5**.
- 3 Press **▲** or **▼** to choose `On` (or `Off`). Press **OK**.
- 4 Press **Stop/Exit**.

Receiving a fax at the end of a conversation

At the end of a conversation, you can ask the other party to send you a fax before you both hang up. Make sure the ADF is empty.

- 1 Ask the other party to place the document in their machine and to press the Start or Send key.
- 2 When you hear the other machine's CNG tones, press **Mono Start** on your machine.
- 3 Press **2** to choose `Receive` to receive the fax.
(When you select the `Fax Mode` to `Advanced Mode`)
- 4 Replace the handset of the external telephone.

Dialling and storing numbers (MFC models only)

Additional dialling operations





Combining Speed Dial numbers

Sometimes, you may want to choose from several long-distance carriers when you send a fax. Rates may vary depending on the time and destination. To take advantage of low rates, you can store the access codes of long-distance carriers and credit card numbers as Speed Dial numbers. (See Basic User's Guide: *Storing Speed Dial numbers.*)



You can store these long dialling sequences by dividing them and setting them up as separate Speed Dial numbers in any combination.

You can even include manual dialling using the dial pad.

For example, you might have stored '01632' on Address Book: #03 and '960555' on Address Book: #02. You can use them both to dial '01632-960555' as shown in the following example:

- 1 Press  (FAX).
- 2 Press  (Address Book).
- 3 Press  or  to choose *Search*. Press **OK**.
- 4 Enter **#, 03**.
- 5 Press  (Address Book).
- 6 Enter **#, 02**.
- 7 Press **Mono Start**.
You will dial '01632-960555'.

To temporarily change a number, you can use the dial pad to manually substitute part of the number. For example, to change the number to '01632-960556', you could enter the number (#03 '01632') using

 (Address Book), choose *Search*, , press **OK**, press **#, 03**, and then press **'960556'** using the dial pad.



NOTE

If you must wait for another dial tone or signal at any point in the dialling sequence, create a pause in the number by pressing **Redial/Pause**. Each key press adds a 3.5 second delay. You can press **Redial/Pause** as many times as needed to increase the length of the pause.

Additional ways to store numbers



Setting up Groups for Broadcasting

A Group, which is stored in a Speed Dial location, allows you to send the same fax message to many fax numbers by pressing

 (FAX),  (Address Book), Search, **OK**, #, the two-digit location number and **Mono Start**.

(See *Broadcasting* on page 7.)

First, you'll need to store each fax number in a Speed Dial location. (See Basic User's Guide: *Storing Speed Dial numbers*.) Then you can include them as numbers in the Group. Each Group uses a Speed Dial location. You can have up to six Groups, or you can assign up to 39 numbers to a large Group.

- 1 Press  (FAX).
- 2 Press  (Address Book) and ▲ or ▼ to choose *Setup Groups*. Press **OK**.
- 3 Use the dial pad to enter the two-digit Speed Dial location number you want to add to the Group. Press **OK**.
- 4 Use the dial pad to enter a Group number (1 to 6). Press **OK**.

- 5 To add Speed Dial numbers to a group, follow the instructions below:
For example, to add Speed Dial numbers #05 and #09, press

 (Address Book), **05**,

 (Address Book), **09**.

The LCD shows:

G01:#05#09



- 6 Press **OK** when you have finished adding numbers.
- 7 Use the dial pad to enter a name (up to 16 characters) for the Group. (For help entering letters, see Basic User's Guide: *Entering Text*.) Press **OK**.

NOTE

You can print a list of all the Speed Dial numbers. (See *Reports* on page 17.)

Changing or deleting a Group

You can change the Speed Dial numbers in a Group. To delete a Group, delete all of its Speed Dial numbers.

- 1 Press  (FAX).
- 2 Press  (Address Book) and ▲ or ▼ to choose *Setup Groups*. Press **OK**.
- 3 Use the dial pad to enter the two-digit Speed Dial location number for the Group you want to change. Press **OK**.
- 4 Do one of the following:
 - Press **1** to change the added Group.
 - Press **2** to return to 3 to enter another Speed Dial location number.
 - Press **Stop/Exit** to exit without making a change.

- 5 Add or delete the Speed Dial numbers in the Group.
 - To add Speed Dial numbers, press ◀ or ▶ to position the cursor under a blank space.

Press  (**Address Book**) and enter the Speed Dial number you want to add to the Group using the dial pad.
 - To delete Speed Dial numbers, press ◀ or ▶ to position the cursor under the Speed Dial number you want to delete, and then press **Clear**.
- 6 Press **OK** when you have finished adding or deleting Speed Dial numbers.
- 7 Enter the new Group name (up to 16 characters) using the dial pad. (For example, type "NEW CLIENTS".) (For help entering letters, see Basic User's Guide: *Entering Text*.) Press **OK**.

NOTE

How to change the stored name or number:

If you want to change a character, press ◀ or ▶ to position the cursor under the character you want to change, and then press **Clear**. Re-enter the character.

6

Printing reports

Fax reports (MFC models only)

You can use the **Menu** keys to set up the Transmission Verification Report and the Journal Period.

Transmission Verification Report

You can use the Transmission Verification Report as proof that you sent a fax. (See Basic User's Guide: *Transmission Verification Report*.)

Fax Journal (activity report)

You can set the machine to print a journal at specific intervals (every 50 faxes; every 6, 12 or 24 hours; or every 2 or 7 days). If you set the interval to `Off`, you can still print the report by following the steps in *How to print a report* on page 17. The factory default is `Every 50 Faxes`.

1 Press **Menu**, **3**, **3**, **2**.

2 Press **▲** or **▼** to choose an interval. Press **OK**.
If you choose `Every 50 Faxes`, go to step 5.

- `Every 6, 12, or 24 hours; every 2 or 7 days`

The machine will print the report at the chosen time and then erase all jobs from its memory. If the machine's memory becomes full with 200 jobs before the time you chose has passed, the machine will print the Journal early and then erase all jobs from the memory. If you want an extra report before it is due to print, you can print it without erasing the jobs from the memory.

- `Every 50 Faxes`

The machine will print the Journal when the machine has stored 50 jobs.

3 If you choose `Every 7 Days`, press **▲** or **▼** to choose the first day for the 7-day countdown. Press **OK**.

4 Enter the time (in 24-hour format) by pressing the keyboard on the control panel. Press **OK**.
(For example: enter 19:45 for 7:45 PM.)

5 Press **Stop/Exit**.

Reports

The following reports are available:

- **XMIT Verify**
(MFC models only)
Prints a Transmission Verification Report for your last transmission.
- **Address Book**
(MFC models only)
Prints a list of names and numbers stored in the Address Book memory, in numerical order.
- **Fax Journal**
(MFC models only)
Prints a list of information about the last incoming and outgoing faxes.
(TX: Transmit.) (RX: Receive.)
- **User Settings**
Prints a list of your settings.
- **Network Config**
(DCP-T500W, DCP-T700W and MFC-T800W)
Prints a list of your Network settings.
- **WLAN Report**
(DCP-T500W, DCP-T700W and MFC-T800W)
Prints a WLAN connection report.
- **Caller ID**
(MFC models only)
Prints a list of the available Caller ID information about the last 30 received faxes and telephone calls.

How to print a report

(MFC-T800W)

- 1 Press **Menu**, **6**.
- 2 Do one of the following:
 - Press **▲** or **▼** to choose the report you want. Press **OK**.
 - Enter the number of the report you want to print.
- 3 Press **Mono Start**.
- 4 Press **Stop/Exit**.

(DCP-T300, DCP-T500W and DCP-T700W)

- 1 Press **Menu**.
- 2 Press **▲** or **▼** to choose **Print Reports**. Press **OK**.
- 3 Press **▲** or **▼** to choose the report you want to print. Press **OK**.
- 4 Press **Mono Start**.
- 5 Press **Stop/Exit**.

7

Making copies

Copy options

You can change the copy settings temporarily for the next copy.

The machine returns to its default settings after being idle for 1 minute.

Press **Copy Options** and then press **▲** or **▼** to choose the copy settings you want. Press **OK**.

Press **Copy Quality**¹ to change the speed and quality of your copies.

When you have finished choosing settings, press **Mono Start** or **Color Start**.

¹ DCP models only

Stop copying

To stop copying, press **Stop/Exit**.

Changing copy speed and quality

You can choose different settings to change the speed and quality of your copies. The factory default is *Normal*.

If you choose *Normal* you can only choose *Plain Paper* in *Paper Type*.

■ Normal

Normal is the recommended mode for ordinary print outs. This produces good copy quality with good copy speed.

■ Best

Use *Best* mode to copy precise images, such as photographs. This provides the highest resolution and slowest speed.

(MFC-T800W)

- 1 Load your document.
- 2 Press  (**COPY**).

- 3 Enter the number of copies you want.
- 4 Press **Copy Options** and **▲** or **▼** to choose *Quality*. Press **OK**.
- 5 Press **▲** or **▼** to choose *Normal* or *Best*. Press **OK**.
- 6 If you do not want to change additional settings, press **Mono Start** or **Color Start**.

To change the default setting, follow the instructions below:

- 1 Press **Menu, 4, 1**.
- 2 Press **▲** or **▼** to choose *Normal* or *Best*. Press **OK**.
- 3 Press **Stop/Exit**.

(DCP-T300, DCP-T500W and DCP-T700W)

- 1 Load your document.
- 2 Enter the number of copies you want.
- 3 Press **Copy Quality** repeatedly to choose *Normal* or *Best*.
- 4 Press **Mono Start** or **Color Start**.

To change the default setting, follow the instructions below:

- 1 Press **Menu**.
- 2 Press **▲** or **▼** to choose *2.COPY*. Press **OK**.
- 3 Press **▲** or **▼** to choose *3.Quality*. Press **OK**.
- 4 Press **▲** or **▼** to choose *Normal* or *Best*. Press **OK**.
- 5 Press **Stop/Exit**.

Enlarging or reducing copies

You can choose an enlargement or reduction ratio. If you choose **Fit to Page**, your machine will adjust to the size you set in **Paper Size**.

(MFC-T800W)

- 1 Load your document.
- 2 Press  (**COPY**).
- 3 Enter the number of copies you want.
- 4 Press **Copy Options** and **▲** or **▼** to choose **Enlarge/Reduce**. Press **OK**.
- 5 Press **▲** or **▼** to choose the enlargement or reduction ratio you want. Press **OK**.

NOTE

If you chose **Custom (25-400%)**, enter an enlargement or reduction ratio from 25% to 400%.

198% 10x15cm→A4
186%10x15cm→LTR
141% A5→A4
100%
97% LTR→A4
93% A4→LTR
83% LGL→A4
69% A4→A5
47% A4→10x15cm
Fit to Page
Custom (25-400%)

- 6 If you do not want to change additional settings, press **Mono Start** or **Color Start**.

(DCP-T300, DCP-T500W and DCP-T700W)

- 1 Load your document.
- 2 Enter the number of copies you want.

- 3 Press **Enlarge/Reduce**.
- 4 Press **▲** or **▼** to choose the enlargement or reduction ratio you want. Press **OK**.

NOTE

If you chose **Custom (25-400%)**, press **▲** or **▼** repeatedly to enter an enlargement or reduction ratio from 25% to 400%.

198% 10x15cm→A4
186%10x15cm→LTR
141% A5→A4
100%
97% LTR→A4
93% A4→LTR
83% LGL→A4 (DCP-T700W)
83% (DCP-T300 and DCP-T500W)
69% A4→A5
47% A4→10x15cm
Fit to Page
Custom (25-400%)

- 5 Press **Mono Start** or **Color Start**.

NOTE

- **Layout (2in1 ID)** is not available with **Enlarge/Reduce - MFC-T800W (Enlarge/Reduce - DCP-T300, DCP-T500W and DCP-T700W)**.
- **Layout (2in1 ID), Sort and Remove Bkg. Clr** are not available with **Fit to Page**.
- **Fit to Page** does not work correctly when the document on the scanner glass is skewed by more than 3 degrees. Using the document guidelines on the left and top, place your document in the upper-left corner, with the document face down on the scanner glass.
- **Fit to Page** is not available when using the ADF ¹.

¹ DCP-T700W and MFC-T800W only

Making N in 1 copies or a poster (Page Layout)

The N in 1 copy feature can help you save paper by letting you copy two or four pages onto one printed page.

You can also produce a poster. When you use the poster feature, your machine divides your document into sections, then enlarges the sections so you can assemble them into a poster. If you want to print a poster, use the scanner glass.

NOTE

Sort, Enlarge/Reduce - MFC-T800W (**Enlarge/Reduce** - DCP-T300, DCP-T500W and DCP-T700W) and Remove Bkg. Clr are not available with Layout (2in1 ID).

- 1 Load your document.
- 2 (MFC models only)
Press  (**COPY**).
- 3 Enter the number of copies you want. ¹
¹ You can only make one copy at a time when you are using Poster layout.
- 4 Press **Copy Options** and ▲ or ▼ to choose Layout (2in1 ID). Press **OK**.
- 5 Press ▲ or ▼ to choose Off (1in1), 2in1 (P), 2in1 (L), 4in1 (P), 4in1 (L), Poster (3x3) or 2in1 (ID) ¹. Press **OK**.

¹ For information about 2 in 1 (ID), see *2 in 1 ID copy (Page Layout)* on page 21.

- 6 If you do not want to change additional settings, press **Mono Start** or **Color Start** to scan the page.

If you placed the document in the ADF ¹ or are making a poster, the machine scans the document and starts printing.

¹ DCP-T700W and MFC-T800W only

If you are using the scanner glass, go to step 7.

- 7 (MFC-T800W)
After the machine has scanned the page, press **1** to scan the next page. (DCP-T300, DCP-T500W and DCP-T700W)
After the machine has scanned the page, press ▲ to scan the next page.
- 8 Place the next page on the scanner glass. Press **OK** to scan the page. Repeat steps 7 and 8 for each page of the layout.
- 9 (MFC-T800W)
After all the pages have been scanned, press **2** to finish. (DCP-T300, DCP-T500W and DCP-T700W)
After all the pages have been scanned, press ▼ to finish.

NOTE

- Make sure the paper size is set to A4 or Letter.
- You can only make one color copy at a time.
- You can only make one Poster copy at a time.
- (P) means Portrait and (L) means Landscape.

Place the document face down in the direction shown below:

■ 2in1 (P)



■ 2in1 (L)



■ 4in1 (P)



■ 4in1 (L)



■ Poster (3x3)

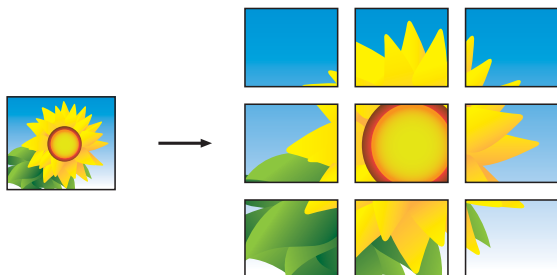

NOTE

The poster copies have overlapping portions so that you can easily paste them together.

2 in 1 ID copy (Page Layout)

You can copy both sides of your identification card onto one page, keeping the original card size. Make sure the paper size is set to A4 or Letter.

NOTE

You can copy an identification card to the extent permitted under applicable laws. (See Product Safety Guide: *Unlawful use of copying equipment.*)

- 1 Place your identification card *face down* near the left corner of the scanner glass as shown in the illustration.

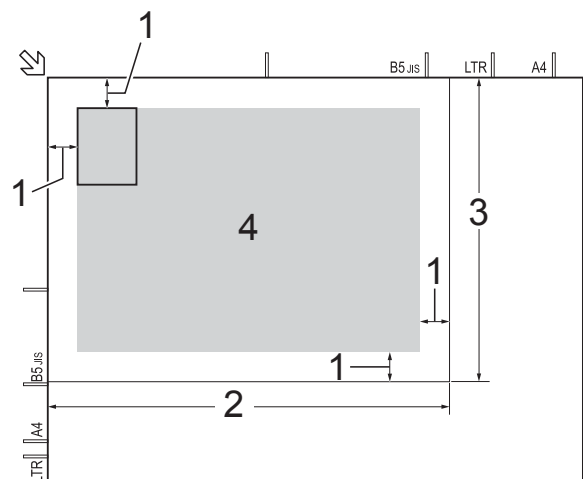

- 1 3 mm or greater (top, left)
- 2 210 mm
- 3 148 mm
- 4 scannable area

- 2 (MFC models only)
Press  (**COPY**).
- 3 Enter the number of copies you want.
- 4 Press **Copy Options** and ▲ or ▼ to choose *Layout (2in1 ID)*. Press **OK**.
- 5 Press ▲ or ▼ to choose *2in1 (ID)*. Press **OK**.

6 Press **Mono Start** or **Color Start**.
The machine starts scanning one side of the identification card.

7 (MFC-T800W)
After the machine has scanned one side, press **1**. Turn over the identification card and press **OK** to scan the other side.
(DCP-T300, DCP-T500W and DCP-T700W)
After the machine has scanned one side, press **▲**.
Turn over the identification card and press **OK** to scan the other side.

NOTE

- *Sort, Enlarge/Reduce* - MFC-T800W (**Enlarge/Reduce** - DCP-T300, DCP-T500W and DCP-T700W) and *Remove Bkg.Clr* are not available with *2in1 (ID)*.
- You can only make one color copy at a time.

Sorting copies

You can sort multiple copies. Pages will be sorted in the order 123, 123, 123, and so on.

We recommend you load single-sided documents in the ADF ¹ for sorting copies. For 2-sided documents and books, use the scanner glass.

¹ DCP-T700W and MFC-T800W only

- 1** Load your document.
- 2** (MFC models only)
Press  (**COPY**).
- 3** Enter the number of copies you want.
- 4** Press **Copy Options** and **▲** or **▼** to choose *Stack/Sort*.
Press **OK**.
- 5** Press **▲** or **▼** to choose *Sort*.
Press **OK**.

6 If you do not want to change additional settings, press **Mono Start** or **Color Start**.

If you placed the document in the ADF ¹, the machine scans the document and starts printing.

¹ DCP-T700W and MFC-T800W only

If you are using the scanner glass, go to step 7.

7 (MFC-T800W)
After the machine scans the page, press **1** to scan the next page.
(DCP-T300, DCP-T500W and DCP-T700W)
After the machine scans the page, press **▲** to scan the next page.

8 Place the next page on the scanner glass. Press **OK** to scan the page. Repeat steps **7** and **8** until all the pages have been scanned.

9 (MFC-T800W)
Press **2** to finish scanning.
The machine starts printing.
(DCP-T300, DCP-T500W and DCP-T700W)
Press **▼** to finish scanning.
The machine starts printing.

NOTE

Fit to Page and *Layout (2in1 ID)* are not available with *Sort*.

Adjusting Density

You can adjust the copy density to make copies darker or lighter.

- 1 Load your document.
- 2 (MFC models only)
Press  (**COPY**).
- 3 Enter the number of copies you want.
- 4 Press **Copy Options** and ▲ or ▼ to choose *Density*.
Press **OK**.
- 5 Press ▲ or ▼ to make a lighter or darker copy.
Press **OK**.
- 6 If you do not want to change additional settings, press **Mono Start** or **Color Start**.

To change the default setting, follow the instructions below:

(MFC-T800W)

- 1 Press **Menu**, 4, 2.
- 2 Press ▲ or ▼ to make a lighter or darker copy.
Press **OK**.
- 3 Press **Stop/Exit**.

(DCP-T300, DCP-T500W and DCP-T700W)

- 1 Press **Menu**.
- 2 Press ▲ or ▼ to choose 2.*Copy*.
Press **OK**.
- 3 Press ▲ or ▼ to choose 4.*Density*.
Press **OK**.
- 4 Press ▲ or ▼ to make a lighter or darker copy.
Press **OK**.
- 5 Press **Stop/Exit**.

Remove Background Color

Removes the background color of the document when copying. This can save ink and help you read the document clearly.

As you select a higher setting, the white background will become more apparent.

NOTE

This function is for use only when making color copies. The background color is automatically removed for all monochrome copies.

- 1 Load your document.
- 2 (MFC models only)
Press  (**COPY**).
- 3 Enter the number of copies you want.
- 4 Press **Copy Options** and ▲ or ▼ to choose *Remove Bkg. Clr.*
Press **OK**.
- 5 Press ▲ or ▼ to choose *Low, Medium, High* or *Off*.
Press **OK**.
- 6 Press **Color Start**.

NOTE

Fit to Page and *Layout (2in1 ID)* are not available with *Remove Bkg. Clr.*

A

Routine maintenance

Cleaning and checking the machine

Cleaning the outside of the machine

Clean the LCD screen as follows:

IMPORTANT

DO NOT use any type of liquid cleaners (including ethanol).

- 1 Press and hold down  to turn the machine off. The LCD will show *Shutting Down* for a few seconds before the power goes off.
- 2 Clean the LCD screen with a *dry*, soft lint-free cloth.

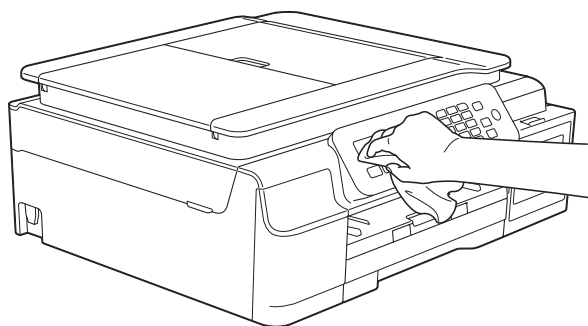

Clean the outside of the machine as follows:

IMPORTANT

- Use neutral detergents. Cleaning with volatile liquids, such as thinner or benzene, will damage the outside surface of the machine.
- DO NOT use cleaning materials that contain ammonia.
- DO NOT use isopropyl alcohol to remove dirt from the control panel. It may crack the panel.

- 1 Pull the paper tray (1) completely out of the machine.

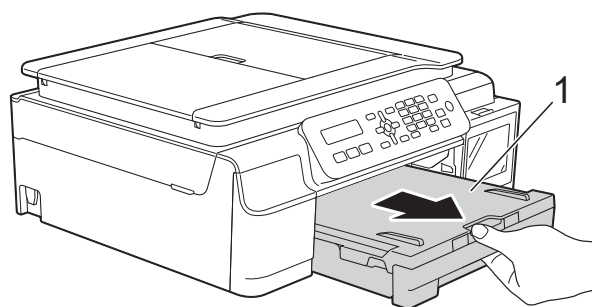

- 2 Wipe the outside of the machine with a *dry*, soft lint-free cloth to remove dust.

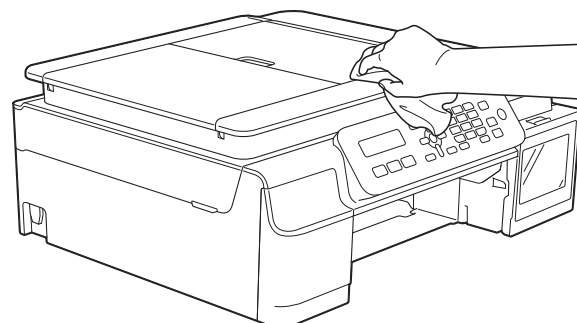

- 3 Lift the output paper tray cover and remove anything that is stuck inside the paper tray.

- 4 Wipe the inside and outside of the paper tray with a *dry*, soft lint-free cloth to remove dust.

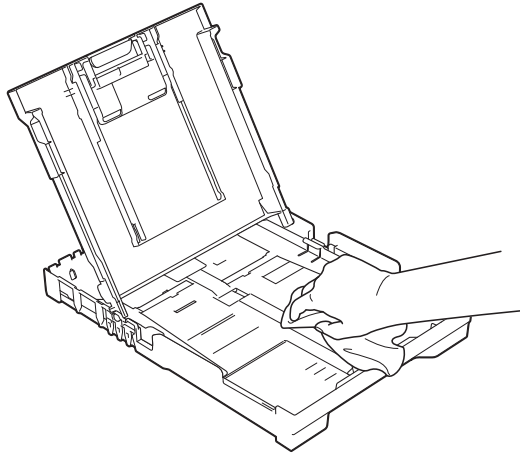

- 5 Close the output paper tray cover and put the paper tray firmly back in the machine.

Cleaning the machine's printer platen

WARNING



Be sure to unplug the machine from the electrical socket before cleaning the printer platen to avoid an electrical shock.

- 1 Place both hands under the plastic tabs on both sides of the machine and lift the scanner cover into the open position.

- 2 Clean the machine's printer platen (1) and the area around it, wiping off any scattered ink with a *dry*, soft lint-free cloth.

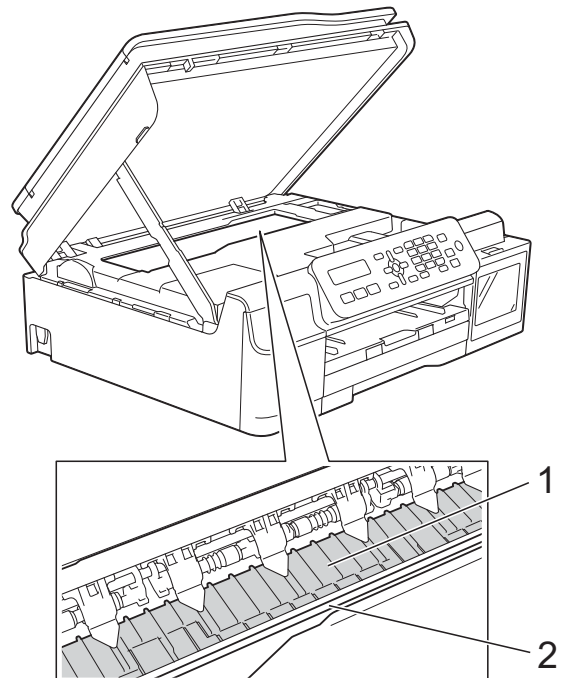

IMPORTANT

DO NOT touch the encoder strip (2). Doing this may cause damage to the machine.

- 3 Lift the scanner cover to release the lock. Gently push the scanner cover support down and close the scanner cover using both hands.
- 4 Re-connect the power cord.

Cleaning the paper feed rollers

If the paper feed rollers are stained with ink, it may cause paper feed problems.

- 1 Unplug the machine from the electrical socket. Pull the paper tray (1) completely out of the machine.

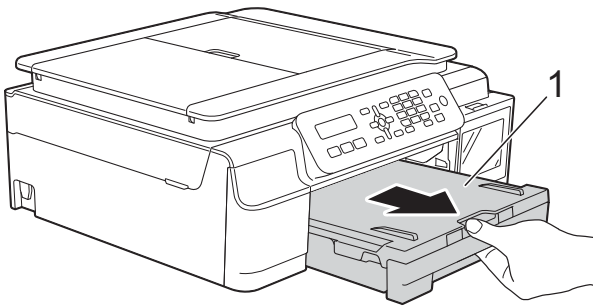

NOTE

If the paper support flap is open, close it, and then close the paper support.

- 2 Clean the Paper Feed Rollers (1) with a soft lint-free cloth slightly moistened with water, using a side-to-side motion. After cleaning, wipe the rollers with a *dry*, soft lint-free cloth to remove all moisture.

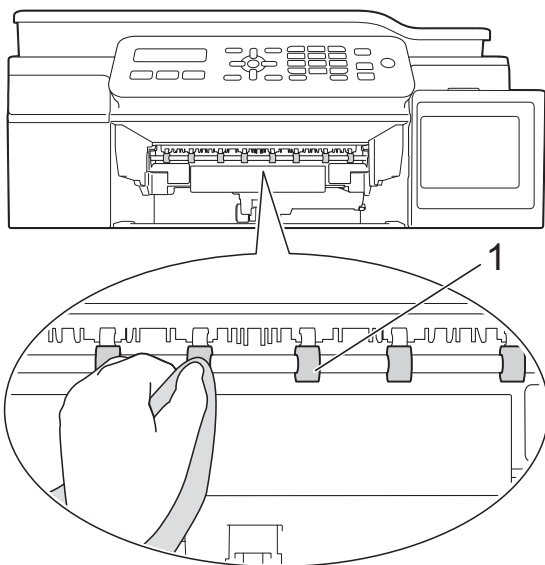

- 3 Put the paper tray firmly back in the machine.
- 4 Re-connect the power cord.

NOTE

Do not use the machine again until the rollers are completely dry. Using the machine before the rollers are dry may cause paper feed problems.

Cleaning the paper pick-up rollers

- 1 Unplug the machine from the electrical socket.
- 2 Pull the paper tray completely out of the machine.

NOTE

If the machine has been feeding multiple pages when there are only a few sheets of paper left in the tray, clean the Base Pad (1) with a soft lint-free cloth slightly moistened with water.

After cleaning, wipe the pad with a *dry*, soft lint-free cloth to remove all moisture.

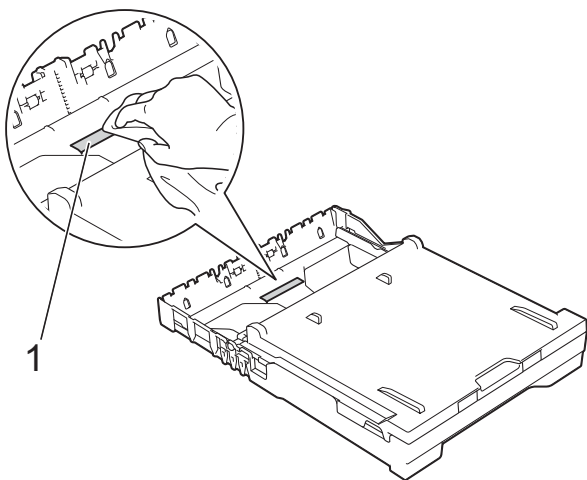

- 3 Open the Jam Clear Cover (1) at the back of the machine.

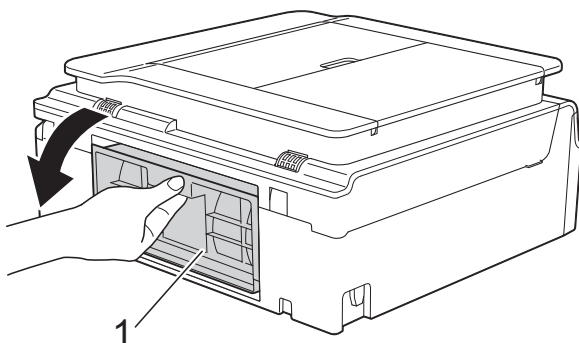

- 4 Clean the Paper Pick-up Rollers (1) with a soft lint-free cloth slightly moistened with water. Slowly turn the rollers so that the whole surface is cleaned. After cleaning, wipe the rollers with a *dry*, soft lint-free cloth to remove all moisture.

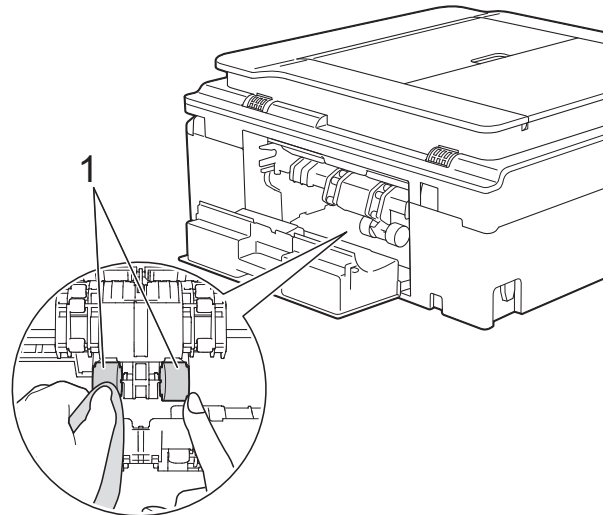

- 5 Close the Jam Clear Cover. Make sure the cover is closed completely.

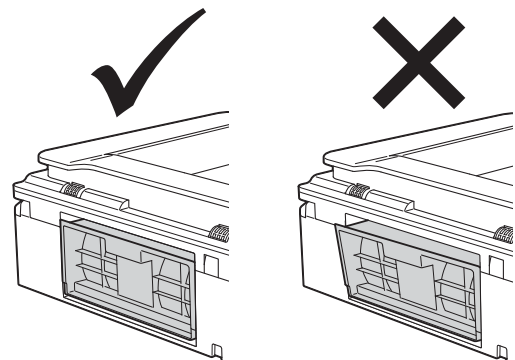

- 6 Put the paper tray firmly back in the machine.
- 7 Re-connect the power cord.

Packing and shipping the machine

When you transport the machine, use the packing materials that came with your machine. Follow the instructions below to correctly package your machine. Damage caused to your machine during transit may not be covered by your warranty.

The machine should be adequately insured with the carrier.

IMPORTANT

It is important to allow the machine to “park” the print head after a print job. Listen carefully to the machine before unplugging it to make sure that all mechanical noises have stopped. Not allowing the machine to finish this parking process may lead to print problems and possible damage to the print head.

- 1 Unplug the machine from the electrical socket.
- 2 Place both hands under the plastic tabs on both sides of the machine to lift the scanner cover into the open position. Then unplug the machine from the telephone wall socket and take the telephone line cord out of the machine.
- 3 Unplug the interface cable from the machine, if it is connected.

- 4 Lift the scanner cover (1) to release the lock. Gently push the scanner cover support down (2) and close the scanner cover (3) using both hands.

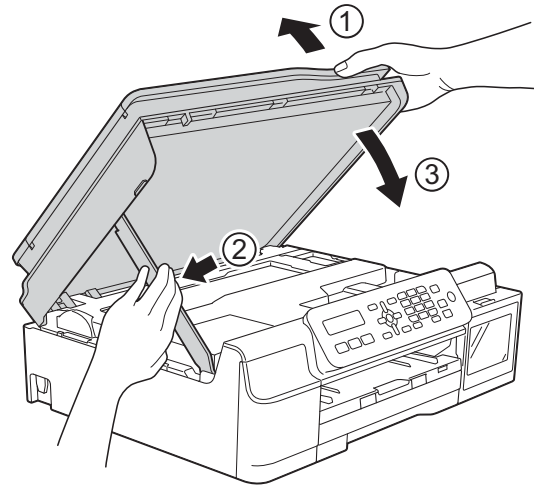

⚠ CAUTION

Be careful not to pinch your fingers when you close the scanner cover.

- 5 Open the ink tank cover.
- 6 Make sure the cap of the ink tank is tightened properly. Press the cap down to tighten it securely onto the ink tank, and then close the ink tank cover.

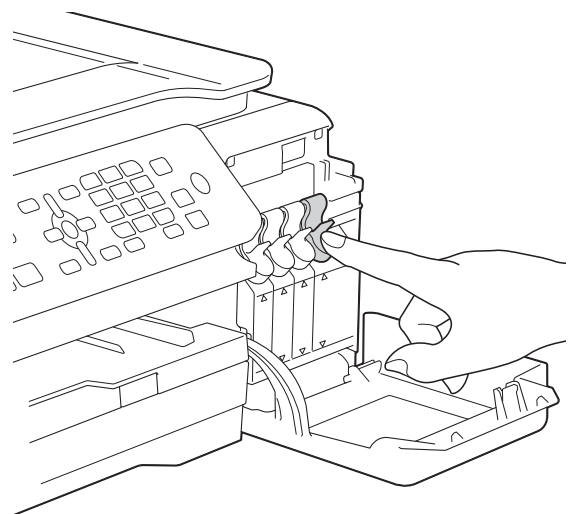

- 7 Wrap the machine in the bag.

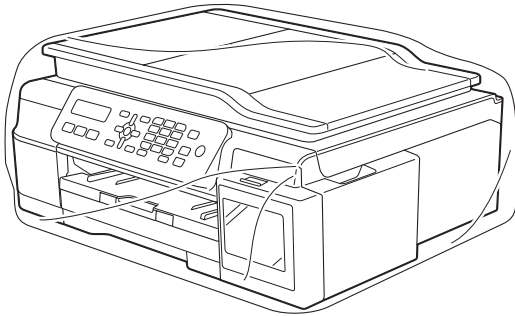

- 8 Pack the machine and the printed materials in the original carton with the original packing material as shown in the illustration.
Do not pack the used ink bottles in the carton.

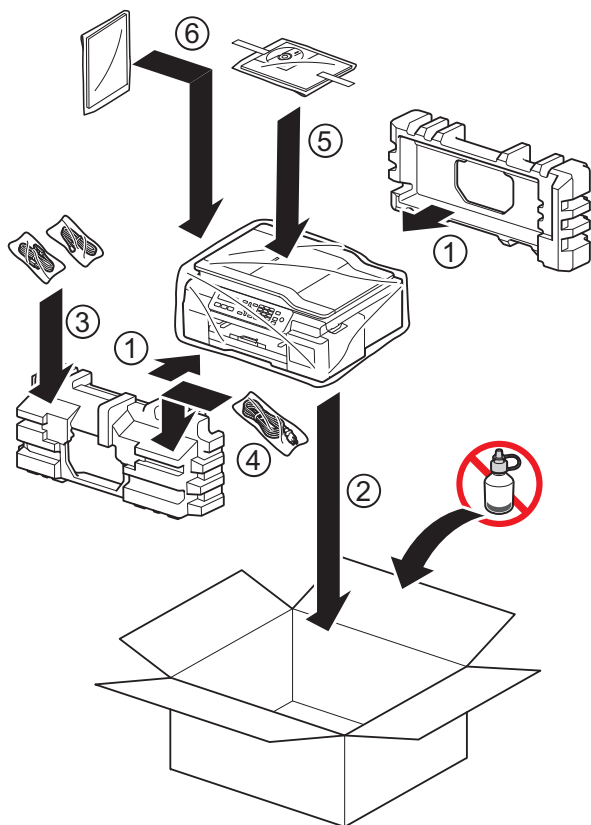

- 9 Close the carton and tape it shut.

B

Glossary

This is a comprehensive list of features and terms that appear in Brother manuals. Availability of these features depends on the model you purchased.

Address Book

Your list of Speed Dial and Group names and numbers that you have stored for easy dialling.

ADF (automatic document feeder)

The document can be placed in the ADF and scanned one page at a time automatically.

Auto Reduction

Reduces the size of incoming faxes.

Automatic fax transmission

Sending a fax without picking up the handset of an external telephone.

Automatic Redial

A feature that enables your machine to redial the last fax number after five minutes if the fax did not go through because the line was busy.

Beeper Volume

Volume setting for the beep when you press a key or make an error.

Brightness

Changing the Brightness makes the whole image lighter or darker.

Broadcasting

The ability to send the same fax message to more than one location.

Caller ID

A service purchased from the telephone company that lets you see the number (or name) of the party calling you.

CNG tones

The special tones (beeps) sent by fax machines during automatic transmission to tell the receiving machine that a fax machine is calling.

Coding method

Method of coding the information contained in the document. All fax machines must use a minimum standard of Modified Huffman (MH). Your machine is capable of greater compression methods, Modified Read (MR), Modified Modified Read (MMR) and JPEG, if the receiving machine has the same capability.

Color Enhancement

Adjusts the color in the image for better print quality by improving sharpness, white balance and color density.

Communication error (Comm. Error)

An error during fax sending or receiving, usually caused by line noise or static.

Compatibility group

The ability of one fax unit to communicate with another. Compatibility is assured between ITU-T Groups.

Contrast

Setting to compensate for dark or light documents, by making faxes or copies of dark documents lighter and light documents darker.

Density

Changing the Density makes the whole image lighter or darker.

ECM (Error Correction Mode)

Detects errors during fax transmission and resends the pages of the fax that had an error.

Extension telephone

A telephone using the same line as your fax but plugged into a separate wall socket.

External telephone

A TAD (telephone answering device) or telephone that is connected to your machine.

F/T Ring Time

The length of time that the Brother machine rings (when the Receive Mode setting is Fax/Tel) to notify you to pick up a voice call that it answered.

Fax Detect

Enables your machine to respond to CNG tones if you interrupt a fax call by answering it.

Fax Journal

Lists information about the last 200 incoming and outgoing faxes. TX means Transmit. RX means Receive.

Fax tones

The signals sent by sending and receiving fax machines while communicating information.

Fax/Tel

You can receive faxes and telephone calls. Do not use this mode if you are using a telephone answering device (TAD).

Fine resolution

Resolution is 203 × 196 dpi. It is used for small print and graphs.

Greyscale

The shades of grey available for copying, scanning and faxing photographs.

Group number

A combination of Speed Dial numbers that are stored in a Speed Dial location for Broadcasting.

Journal Period

The pre-programmed time period between automatically printed Fax Journal reports. You can print the Fax Journal report on demand without interrupting the cycle.

LCD (Liquid Crystal Display)

The display screen on the machine that shows interactive messages during On-Screen Programming and shows the date and time when the machine is idle.

Manual fax

You can press **Hook** to hear the receiving fax machine answer before you press **Mono Start** to begin sending the fax.

Memory Receive

Receives faxes into the machine's memory when the machine is out of paper.

Menu mode

Programming mode for changing your machine's settings.

OCR (optical character recognition) (MFC models only)

Presto! PageManager software application converts an image of text to text you can edit.

Overseas Mode

Makes temporary changes to the fax tones to accommodate noise and static on overseas telephone lines.

Pause

Allows you to place a 3.5 second delay in the dialling sequence while you are dialling using the dial pad or while you are storing Speed Dial numbers. Press **Redial/Pause** key on the control panel as many times as needed for longer pauses.

Photo resolution

A resolution setting that uses varying shades of grey for the best representation of photographs.

Pulse

A form of rotary dialling on a telephone line.

Real Time Transmission

When the memory is full, you can send faxes in real time.

Remaining jobs

You can check which jobs are waiting in memory and cancel jobs individually.

Remote Activation Code

Press this code (* 5 1) when you answer a fax call on an extension or external telephone.

Remote Deactivation Code (For Fax/Tel mode only)

When the machine answers a voice call, it fast double-rings. You can pick up at an extension telephone by pressing this code (# 5 1).

Resolution

The number of vertical and horizontal lines per inch. (See Standard resolution, Fine resolution, Super Fine resolution and Photo resolution.)

Ring Delay

The number of rings before the machine answers in Fax Auto and Fax/Tel modes.

Ring Volume

Volume setting for the machine's ring.

Scanning

The process of sending an electronic image of a paper document to your computer.

Search

A numerical or alphabetical electronic listing of stored Speed Dial and Group numbers.

Settings Tables

At-a-glance instructions that show all the settings and options that are available for setting up your machine.

Speed Dial

You can set up names and numbers for easy dialling.

Standard resolution

203 × 98 dpi. It is used for regular sized text and the quickest transmission.

Station ID

The stored information that appears on the top of faxed pages. It includes the sender's name and fax number.

Super Fine resolution

203 × 392 dpi. Best for very small print and line art.

TAD (telephone answering device)

You can connect an external TAD to your machine.

Temporary settings

You can choose certain options for each fax transmission and copy without changing the default settings.

Tone

A form of dialling on the telephone line used for touch-tone telephones.

Transmission

The process of sending faxes over the phone lines from your machine to the receiving fax machine.

Transmission Verification Report

A listing for each fax sent, that shows its date, time and number.

User Settings

A printed report that shows the current settings of the machine.

WLAN Report

A printed report that shows the result of the WLAN Connection.

C

Index

Numerics

2 in 1 ID Copy21

A

Access codes, storing and dialling 13

Address Book

 Broadcasting (Group dial)7

 Cancelling a Broadcast8

 changing Groups14

 deleting Groups14

 setting up Groups for Broadcasting ... 14

 using Groups7

Apple Macintosh

 See Software and Network User's Guide.

B

Broadcasting7

 setting up Groups for 14

C

Caller ID

 Caller ID History report 17

Cancelling

 jobs awaiting redial9

Cleaning

 paper feed rollers26

 printer platen25

ControlCenter

 See Software and Network User's Guide.

Copy

 2 in 1 ID21

 density23

 enlarge/reduce19

 page layout (N in 1)20

 poster20

 quality18

 remove background color23

 sort22

 using ADF22

D

Dialling

 access codes and credit card

 numbers 13

 Groups (Broadcasting) 7

F

Fax Storage

 printing from memory 10

 turning off 11

Fax, from PC

 See Software and Network User's Guide.

Fax, stand-alone

 receiving

 at end of conversation 12

 into PC 10

 into the memory 12

 out of paper reception 12

 printing from memory 10

 reducing to fit on paper 12

 sending 5

 at end of conversation 7

 Broadcasting 7

 cancelling from memory 9

 contrast 5

 manual 6

 overseas 9

 Real Time Transmission 8

 Resolution 5

G

Groups for Broadcasting 14

I

ID Copy 21

L

LCD (Liquid Crystal Display)

 Contrast 2

M

- Macintosh
 - See Software and Network User's Guide.
- Manual
 - transmission6
- Memory Storage 1
- Mode, entering
 - Timer2

N

- Network
 - Printing
 - See Software and Network User's Guide.
 - Scanning
 - See Software and Network User's Guide.

P

- Packing and shipping the machine28
- Power failure 1
- Presto! PageManager
 - See Software and Network User's Guide.
 - Also see Help in the Presto! PageManager application.
- Print
 - fax from memory10
 - report17
- Printing
 - See Software and Network User's Guide.

R

- Reducing
 - copies 19
 - incoming faxes 12
- Remote Setup
 - See Software and Network User's Guide.
- Reports 16
 - Address Book 17
 - Caller ID history 17
 - Fax Journal 17
 - Journal Period 16
 - how to print 17
 - Network Configuration 17
 - Transmission Verification 16, 17
 - User Settings 17
 - WLAN Report 17
- Resolution
 - setting for next fax 5

S

- Scanning
 - See Software and Network User's Guide.
- Shipping the machine 28
- Sleep Mode 1

T

- TX Lock
 - turning on/off 4

W

- Windows®
 - See Software and Network User's Guide.
- Wireless Network
 - See Quick Setup Guide and Software and Network User's Guide.

brother

Visit us on the World Wide Web
<http://www.brother.com>

These machines are approved for use in the country of purchase only. Local Brother companies or their dealers will only support machines purchased in their own countries.



www.brotherearth.com