



(EU only)

brother



Product Safety Guide

DCP-J785DW/MFC-J985DW

Brother Industries, Ltd.

15-1, Naeshiro-cho, Mizuho-ku, Nagoya 467-8561, Japan

Please read this booklet before attempting to operate the product, or before attempting any maintenance. Failure to follow these instructions may result in an increased risk of fire, electrical shock, burns or suffocation. Brother shall not be liable for damage caused where the product owner has failed to follow instructions set out in this guide.

How to use this guide:

- 1 Read the whole guide before using your product and keep it for later reference.
- 2 Carefully follow the instructions set out in this guide and always ensure that you follow all warnings and instructions marked on the product.
- 3 If you have concerns about how to use your product after reading this guide, please contact Brother customer service or your local Brother dealer.
- 4 To ensure you understand all of the instructions, study the Symbols and Conventions used in the documentation.

Symbols and conventions used in the documentation

The following symbols and conventions are used throughout the documentation.

Follow all warnings and instructions marked on the product.

WARNING

WARNING indicates a potentially hazardous situation which, if not avoided, could result in death or serious injuries.

CAUTION

CAUTION indicates a potentially hazardous situation which, if not avoided, may result in minor or moderate injuries.

IMPORTANT

IMPORTANT indicates a potentially hazardous situation which, if not avoided, may result in damage to property or loss of product functionality.

NOTE

NOTE specifies the operating environment, conditions for installation, or special conditions of use.



Prohibition icons indicate actions that must not be performed.



This icon indicates that flammable sprays must not be used.



This icon indicates that organic solvents such as alcohol and liquids must not be used.



Electrical Hazard icons alert you to possible electrical shocks.



Fire Hazard icons alert you to the possibility of a fire.

Bold

Bold typeface identifies specific keys on the machine's control panel or on the computer screen.

Italics

Italicized typeface emphasizes an important point or refers you to a related topic.

Courier New

Text in the Courier New font identifies messages on the LCD of the product.

NOTE

The illustrations in this guide show the MFC-J985DW.

Compilation and Publication Notice

This product's manuals have been compiled and published to provide the latest product safety information at the time of publication. The information contained in the manuals may be subject to change.

For the latest manuals, please visit us at support.brother.com.

Choose a safe location for your product



WARNING



Choose a location where the temperature remains between 10°C and 35°C and the humidity is between 20% to 80% (without condensation).



DO NOT expose the product to direct sunlight, excessive heat, open flames, corrosive gasses, moisture or dust.

Doing so may create a risk of an electrical shock, electrical short or fire. It may also damage the product and/or render it inoperable.



DO NOT place the product near chemicals or in a place where chemicals could be spilled on it. Should chemicals come into contact with the product, there may be a risk of fire or electric shock.

In particular, organic solvents or liquids such as benzene, paint thinner, polish remover, or deodoriser may melt or dissolve the plastic cover and/or cables, resulting in a risk of fire or electric shock. These or other chemicals may also cause the product to malfunction or become discoloured.

CAUTION

Put your product on a flat, stable surface that is free from shocks and vibrations, such as a desk. Put the product near a telephone socket (MFC models only) and a standard grounded electrical socket.

DO NOT place heavy objects on the product. DO NOT place this product on an unstable cart, stand, or table, particularly if children are expected to be near the product. The product is heavy and may fall, causing injury to you or others, and serious damage to the product. For the products with scanning functionality, there is an added risk of injury if the scanner glass should break.

Avoid placing your product in a high-traffic area. If you must place it in a high-traffic area, ensure that the product is in a safe location where it cannot be accidentally knocked-over, which could cause injury to you and serious damage to the product.

IMPORTANT

- DO NOT put objects on top of the product. Doing so could increase the risk of overheating should the product malfunction.
 - DO NOT place anything in front of the product that will block received faxes (MFC models only) or printed pages. DO NOT place anything in the path of received faxes (MFC models only) or printed pages.
 - DO NOT place your product next to sources of interference, such as speakers or the base units of non-Brother cordless telephones. Doing so may interfere with the operation of the product's electronic components.
 - DO NOT place the product on any tilted/slanted surface. DO NOT tip the product after the ink cartridges are installed. Doing so may cause ink spillage and internal damage to the product.
-

General precautions

WARNING

Plastic bags are used in the packing of your product. Plastic bags are not toys. To avoid the danger of suffocation, keep these bags away from babies and children and dispose of them correctly.

DO NOT use the product near any medical electrical equipment. The radio emissions from the product may affect medical electrical equipment and cause a malfunction, which may result in a medical accident.

For users with pacemakers:

This product generates a weak magnetic field. If you experience any unusual symptoms with your pacemaker while near the product, move away from the product and consult a doctor immediately.



DO NOT use flammable substances, any type of spray, or an organic solvent/liquid containing alcohol or ammonia to clean the inside or outside of the product. Doing so could cause a fire or electrical shock. Instead, use only a dry, lint-free cloth. For instructions on how to clean the product, see the *Online User's Guide*.

CAUTION

Wait until pages have exited the product before picking them up. Failure to do this may cause injury to your fingers by trapping them in a roller.

DO NOT put your hand or any foreign objects into the ink insertion slot. Doing this may cause injury.

To prevent injuries, be careful not to put your fingers in the areas shown in the illustrations.

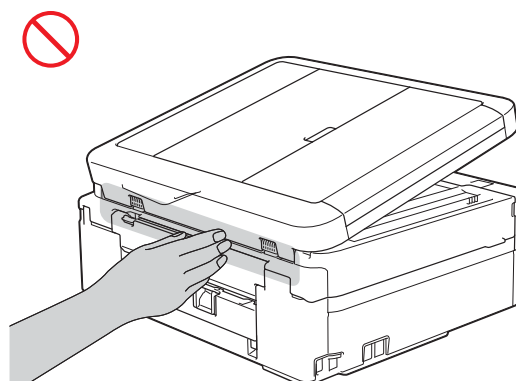
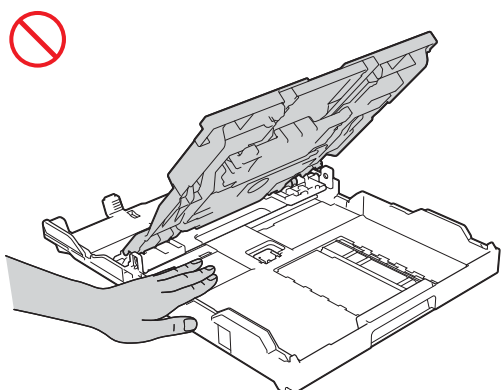
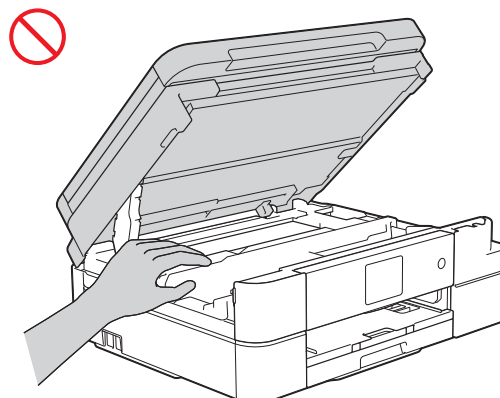
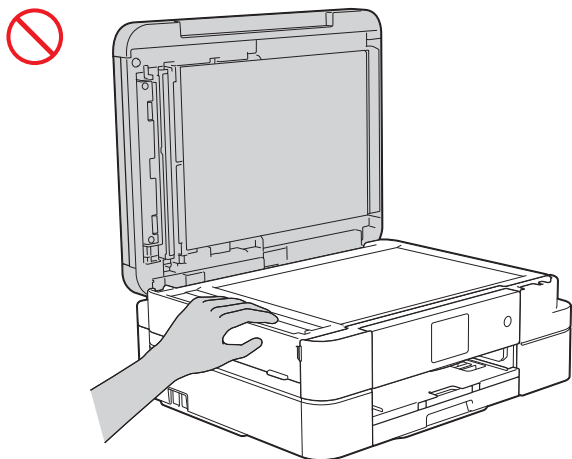

DO NOT touch the edges of the metal parts behind the rollers in the grey shaded area shown in the illustration. Doing this may cause injury to your fingers by cutting them.

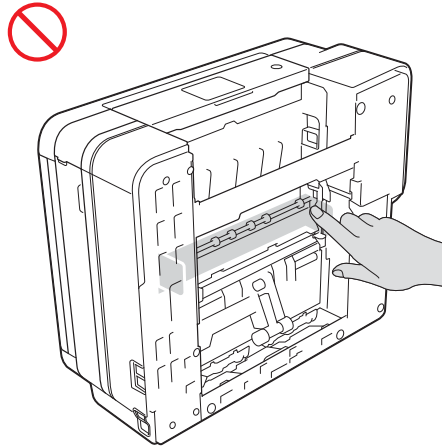

Do not apply weight or pressure to the grey shaded area shown in the illustration below. Doing so may cause the ADF document support (1) to inadvertently open.

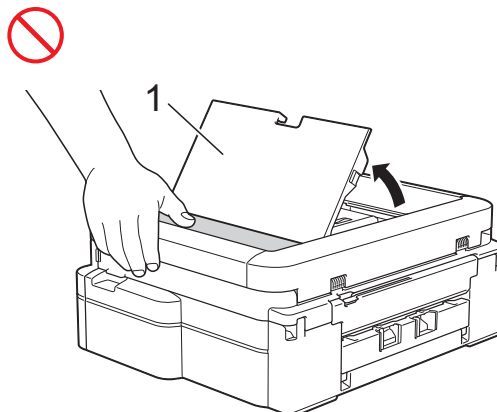

DO NOT carry the product by holding the scanner cover, the Jam Clear Cover, the manual feed slot cover (some models only), or the control panel. Doing so may cause the product to slip out of your hands.

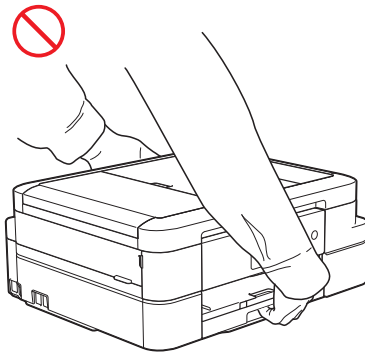
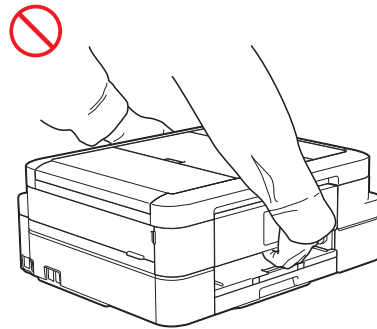
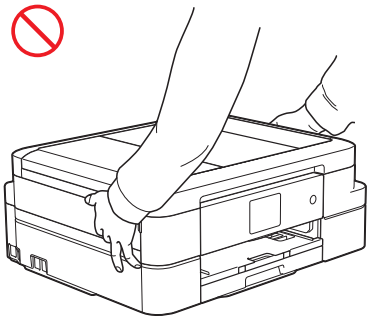

Only carry the machine by placing your hands under the entire machine.

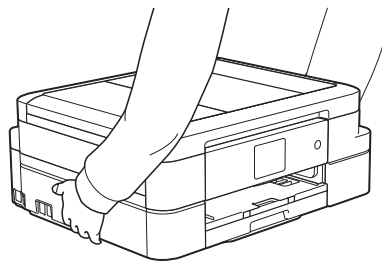

If ink comes into contact with your skin, or into your eyes or mouth, please follow these steps immediately:

- If ink is on your skin, wash it away with water and soap immediately.
- If ink gets into your eyes, rinse them with water immediately. If left as it is, it may cause red eye or mild inflammation. In case of any abnormality, consult your doctor.
- If ink gets into your mouth, spit it out and consult your doctor immediately.

-
- Be careful not to get ink in your eyes when replacing the ink cartridge.
 - Keep the ink cartridge out of the reach of children.
 - Avoid swallowing ink.
 - DO NOT shake the ink cartridge. The ink may leak out if the cartridge is shaken.
 - DO NOT dismantle the ink cartridge. The ink may get in your eyes, or on your skin.

DO NOT run your hand over the edge of the printer paper.
Sharp edges of the paper may cause an injury.

IMPORTANT

- Disruption of power can wipe out information in the product's memory.
 - DO NOT connect your product to an electrical socket on the same circuit as large appliances or other equipment that requires a significant amount of electricity to operate. Operating this product in conjunction with the other product(s) could create an overvoltage, tripping circuit breakers or blowing fuses.
 - We recommend that you only use our genuine ink cartridges.
Use of non-genuine ink may cause damage to the print head, and also result in variations in colours and print quality.
-

Connecting the product safely

WARNING



There are high-voltage electrodes inside the product. Before you access the inside of the product, including for routine maintenance such as cleaning, make sure you have unplugged the power cord from the electrical socket as well as any telephone (RJ-11) (MFC models only) or Ethernet (models with Wired LAN interface only) cables from the product.

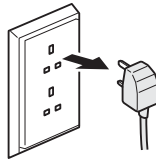

DO NOT handle the plug with wet hands.

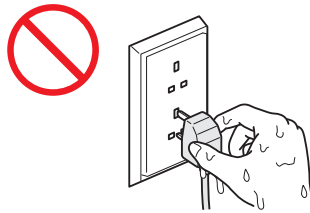

Always make sure the plug is fully inserted.



DO NOT allow the plug, power outlet or the product to become dusty.



DO NOT attempt to service this product yourself. Opening or removing covers may expose you to dangerous voltages and other risks, and may void your warranty. If you experience any problems with your product, contact Brother customer service or your local Brother dealer.



DO NOT allow any type of liquid to come into contact with the plug or power outlet.



If water, other liquids, or metal objects get inside the product, immediately unplug the product from the electrical socket, and contact Brother customer service or your local Brother dealer.



This product should be connected to an AC power source within the range indicated on the rating label. DO NOT connect it to a DC power source or inverter. If you are not sure what kind of power source you have, contact a qualified electrician.



Power Cord Safety:

- DO NOT allow anything to rest on the power cord.
 - DO NOT place this product where people can walk on the cord.
 - DO NOT place this product in a position where the cord is stretched, or strain is otherwise put on the cord.
 - Doing so may cause the cord to become worn or frayed.
-



This product is equipped with a 3-wire grounded plug. This plug will only fit into a grounded power outlet. This is a safety feature. If you are unable to insert the plug into the outlet, call your electrician to replace your obsolete outlet. DO NOT use the supplied grounded plug in any other outlet except those specified. Doing so may cause an electrical shock.

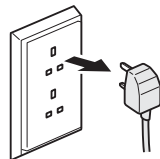



(MFC models only)

Use caution when installing or modifying telephone lines.

Never touch telephone wires or terminals that are not insulated unless the telephone line has been unplugged at the wall socket. Never install telephone wiring during a lightning storm. Never install a telephone wall socket in a wet location.



DO NOT use the product or handle the cord if the cord has become worn or frayed. If unplugging your product, DO NOT touch the damaged/frayed part.



DO NOT pull on the middle of the AC power cord. DO NOT allow anything to rest on the power cord. DO NOT place this product where people may step on the cord. Doing so may cause an electrical shock or fire.



Brother strongly recommends that you DO NOT use any type of extension cord.

Servicing the product

WARNING



If the product has been dropped or the casing has been damaged, there may be the possibility of an electric shock. Unplug the product from the electrical socket and contact Brother customer service or your local Brother dealer.



If the product becomes unusually hot, releases smoke, generates any strong smells, or if you accidentally spill any liquid on it, immediately unplug the product from the electrical socket. Call your Brother dealer or Brother customer service.

IMPORTANT

If the product does not operate normally when the operating instructions are followed, adjust only those controls that are covered by the operating instructions. Incorrect adjustment of other controls may result in damage and will often require extensive work by a qualified technician to restore the product to normal operation.

Product Warranty & Liability

Nothing in this guide shall affect any existing product warranty or be construed as granting any additional product warranty. Failure to follow the safety instructions in this guide may invalidate your product's warranty.

WARNING

DO NOT allow this product to come into contact with water. This product should not be used around standing water, including a bath tub, sink, or swimming pool; around appliances containing water, including a refrigerator; or in a wet basement.

Avoid using this product during an electrical storm. There may be a remote risk of electric shock from lightning.

DO NOT use this product to report a gas leak in the vicinity of the leak.

Only use the power cord supplied with this product.

CAUTION

This product must be installed near an electrical socket that is easily accessible. In case of an emergency, you must unplug the power cord from the electrical socket to shut off the power completely.

Approval Information (MFC models only)

THIS EQUIPMENT IS DESIGNED TO WORK WITH A TWO WIRE ANALOGUE PSTN LINE FITTED WITH THE APPROPRIATE CONNECTOR.

Brother advises that this product may not function correctly in a country other than where it was originally purchased, and does not offer any warranty in the event that this product is used on public telecommunication lines in another country.

Wiring information (U.K. only)

If you need to replace the fuse in the plug, fit a fuse that is approved by ASTA to BS1362 with the same rating as the original fuse. Always replace the fuse cover. Never use a plug that does not have a cover. If in any doubt, call a qualified electrician.

Warning - This product must be earthed.

The wires in the mains lead are coloured in line with the following code:

- Green and Yellow: Earth
- Blue: Neutral
- Brown: Live

Declaration of Conformity (Europe only)

We, Brother Industries Ltd.

15-1 Naeshiro-cho, Mizuho-ku, Nagoya 467-8561 Japan

declare that this product is in conformity with the essential requirements of all relevant directives and regulations applied within the European Community.

The Declaration of Conformity (DoC) can be downloaded from our website. Visit support.brother.com and:

-> select "Manuals"

-> select your model

Declaration of Conformity for R&TTE (Radio and Telecommunications) Directive 1999/5/EC (Europe only) (Applicable to models with telecommunications and/or radio interfaces)

We, Brother Industries Ltd.

15-1 Naeshiro-cho, Mizuho-ku, Nagoya 467-8561 Japan

declare that these products are in conformity with the provisions of the R&TTE Directive 1999/5/EC. A copy of the Declaration of Conformity can be downloaded by following the instructions in the Declaration of Conformity (Europe only) section.

Wireless LAN

This Multifunction Printer supports Wireless LAN.

Frequency band(s): 2400 - 2483.5 MHz

Maximum radio-frequency power transmitted in the frequency band(s): Less than 20 dBm (e.i.r.p)

NFC (Models with NFC function only)

This Multifunction Printer supports NFC (Near Field Communication).

Frequency band(s): 13.553 - 13.567 MHz

LAN connection (Models with Wired LAN function only)

IMPORTANT

DO NOT connect this product to a LAN connection that is subject to over-voltages.

Radio interference

This product complies with EN55022 (CISPR Publication 22)/Class B. When connecting the product to a computer, ensure that you use a USB cable which does not exceed 2 metres in length.

Recycling information in accordance with the WEEE and Battery Directives



Product mark



Battery mark

European Union only

The product/battery is marked with one of the above recycling symbols. It indicates that at the end of the life of the product/battery, you should dispose of it separately at an appropriate collection point and not place it in the normal domestic waste stream.

Imaging Equipment Voluntary Agreement

(This applies to new models placed on the EU market after January 2015.)

Brother warrants that service parts will be available for at least five years after the end of production.

To obtain service parts, please contact your Brother supplier or dealer.

International ENERGY STAR® Compliance Statement

The purpose of the International ENERGY STAR® Program is to promote the development and popularization of energy-efficient office equipment.

As an ENERGY STAR® Partner, Brother Industries, Ltd. has determined that this product meets the ENERGY STAR® guidelines for energy efficiency.



Trademarks

Microsoft, Windows, Windows Vista and Windows Server are either registered trademarks or trademarks of Microsoft Corporation in the United States and/or other countries.

Macintosh, iPad, iPhone, iPod touch and OS X are trademarks of Apple Inc., registered in the United States and other countries.

AirPrint and the AirPrint logo are trademarks of Apple Inc.

AOSS is a trademark of Buffalo Inc.

Wi-Fi and Wi-Fi Direct are registered trademarks of Wi-Fi Alliance.

WPA and WPA2 are trademarks of Wi-Fi Alliance.

©2015 Google Inc. All rights reserved.

Android, Google Cloud Print and Google Play are trademarks of Google, Inc. Use of these trademarks are subject to Google Permissions.

Each company whose software title is mentioned in this manual has a Software License Agreement specific to its proprietary programs.

Any trade names and product names of companies appearing on Brother products, related documents and any other materials are all trademarks or registered trademarks of those respective companies.

Open Source Licensing Remarks

This product includes open-source software.

To see the open source licensing remarks, please go to the manual download selection of your model's home page on Brother Solutions Center at support.brother.com.

Copyright and License

©2016 Brother Industries, Ltd. All rights reserved.

This product includes software developed by the following vendors:

©1983-1998 PACIFIC SOFTWARES, INC. ALL RIGHTS RESERVED.

©2008 Devicescape Software, Inc. All rights reserved.

This product includes the "KASAGO TCP/IP" software developed by ZUKEN ELMIC, Inc.

Other Information

FlashFX[®] is a registered trademark of Datalight, Inc.

FlashFX[®] Copyright 1998-2014 Datalight, Inc.

U.S. Patent Office 5,860,082/6,260,156

FlashFX[®] Pro[™] is a trademark of Datalight, Inc.

FlashFX[®] Tera[™] is a trademark of Datalight, Inc.

Reliance[™] is a trademark of Datalight, Inc.

Reliance Nitro[™] is a trademark of Datalight, Inc.

Datalight[®] is a registered trademark of Datalight, Inc.

Copyright 1989-2014 Datalight, Inc., All Rights Reserved

Brother Customer Service

Customer Service

Visit www.brother.com for contact information for your local Brother office.

Service centre locations

For service centres in your country, contact your local Brother Office. Address and telephone contact information for local offices can be found at www.brother.com by selecting your country.

Unlawful use of copying equipment

It is an offence to make reproductions of certain items or documents with the intent to commit fraud. The following is a non-exhaustive list of documents which it may be unlawful to produce copies of. We suggest you check with your legal adviser and/or the relevant legal authorities if in doubt about a particular item or document:

- Currency
- Bonds or other certificates of indebtedness
- Certificates of deposit
- Armed forces service or draft papers
- Passports
- Postage stamps (cancelled or uncanceled)
- Immigration papers
- Welfare documents
- Cheques or drafts drawn by governmental agencies
- Identifying badges or insignias

In addition, driving licenses and/or Certificates of Title to motor vehicles may not be copied under certain national laws.

Copyrighted works cannot be copied lawfully, subject to the “fair dealing” exception relating to sections of a copyrighted work. Multiple copies would indicate improper use. Works of art should be considered the equivalent of copyrighted works.

brother



www.brotherearth.com

LEX246004-00
UK
Version 0