



D036JX001-00
UK
Version 0

Quick Setup Guide



DCP-L1630W / DCP-L1632W

Read the *Product Safety Guide* first, then read this *Quick Setup Guide* for the correct installation procedure.
Not all models are available in all countries.

EN



The latest manuals are available on the Brother support website:
support.brother.com/manuals

Unpack the machine and check the components

Remove the protective tape or film covering the machine and the supplies.

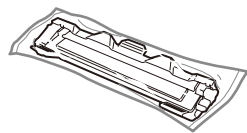
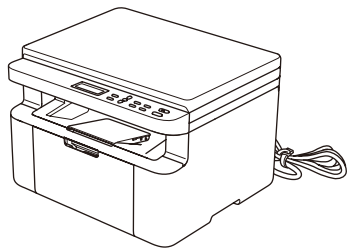

Toner Cartridge



A5 Paper Long Edge Support



Quick Setup Guide



Product Safety Guide

NOTE:

- The components included in the box may differ depending on your country.
- The available connection interfaces vary depending on the model.
If you use a wired connection, you must purchase the correct cable for the interface you want to use.
 - **USB cable**
We recommend using a USB 2.0 cable (Type A/B) that is no more than 2 metres long.
 - **Network cable**
Use a straight-through Category 5 (or greater) twisted-pair cable.
- The screens and images in this *Quick Setup Guide* show the DCP-L1632W.
- Brother aims to reduce waste and save both raw materials and the energy required to produce them.
Read more about our environmental work at www.brotherearth.com.
- Save all packing materials and the box in case you need to ship your machine.

1 Remove the packing materials and install the toner cartridge

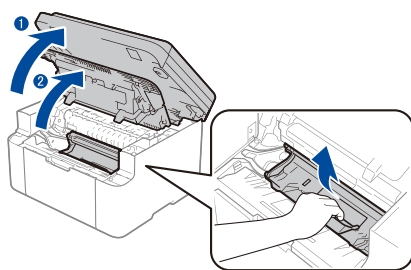

Drum Unit (Remove the drum unit)

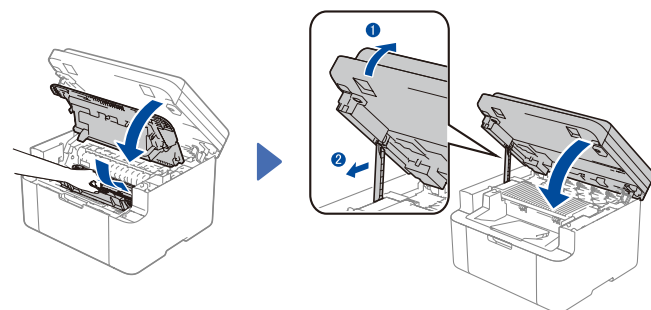
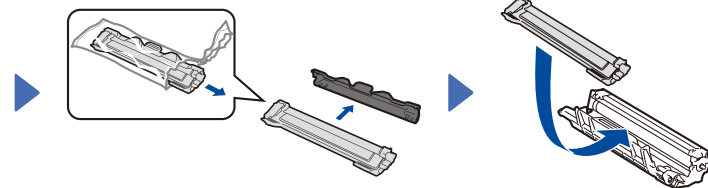

2 Load paper in the paper tray

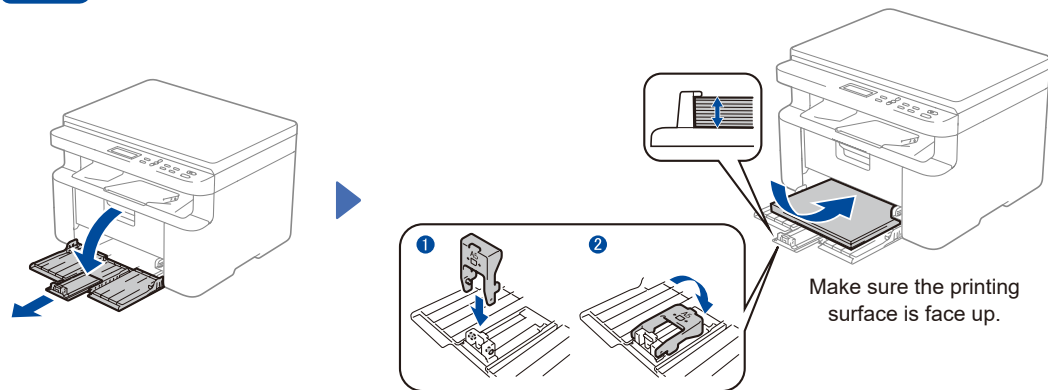

For the long edge of A5 paper

Make sure the printing surface is face up.

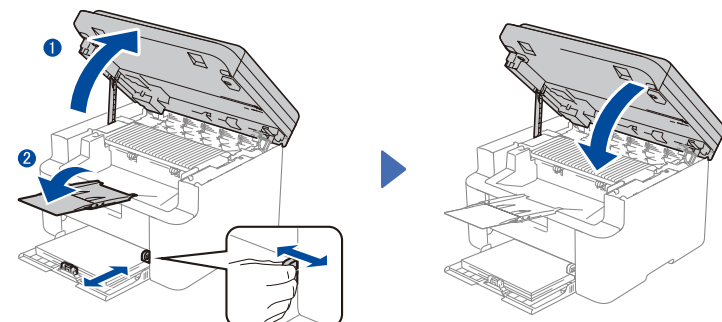

Adjust the paper guides to fit the paper being used.

3 Connect the power cord and turn the machine on

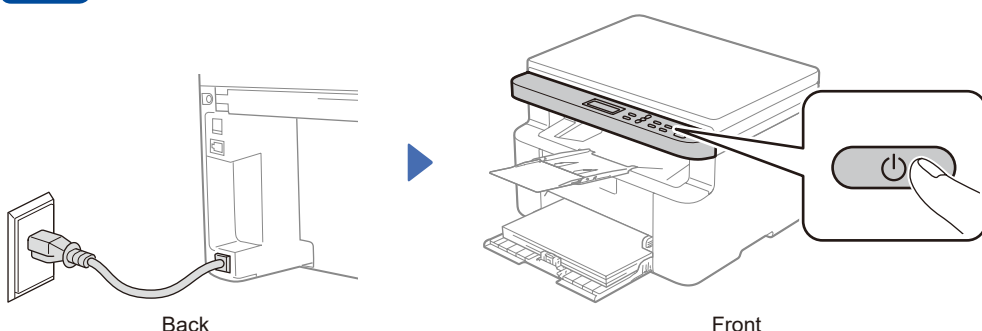

Back

Front

4 Select your country/language (Initial setup only)

After turning the machine on, you may be required to set your country or language (depending on your machine).
If required, follow the on-screen instructions.



5 Select your language (if needed)

1. Press **Menu**.
2. Press **▲** or **▼** to display [Initial Setup], and then press **OK**.
3. Press **▲** or **▼** to display [Local Language], and then press **OK**.
4. Press **▲** or **▼** to select your language, and then press **OK**.
5. Press **Stop/Exit**.

6 Connect your computer or mobile device to your machine

Follow these steps to complete the setup using one of the connection types available on your machine.

Visit setup.brother.com to download and install Brother software.

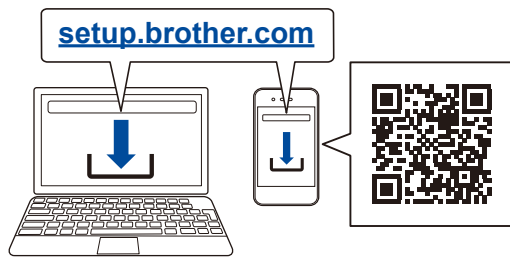

Follow the on-screen instructions and prompts.

Setup Finished

You can now print and scan using your machine.

Important Notice for Network Security:

The default password to manage this machine's settings is located on the back of the machine and marked "Pwd". We recommend immediately changing the default password to protect your machine from unauthorised access.

Can't Connect? Check the following:

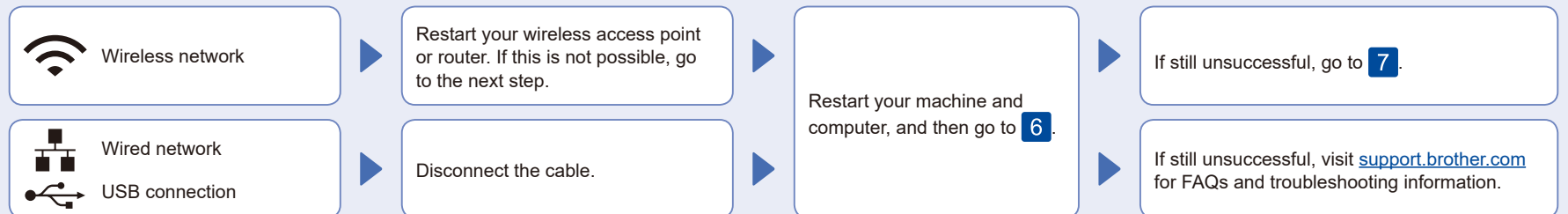

7 Manual wireless setup (Wireless models)

If the wireless setup is unsuccessful, set up the connection manually.

Find your SSID (Network Name) and Network Key (Password) on your wireless access point or router and write them in the table provided below.

SSID (Network Name)	
Network Key (Password)	

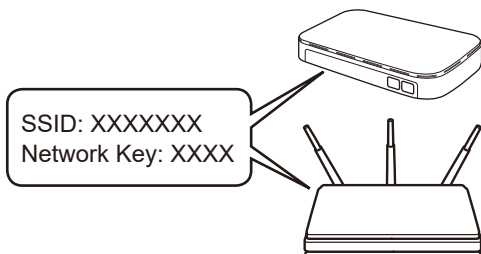

Press **Menu**, and then select [Network] > [WLAN (Wi-Fi)] > [Find Network]. Follow the LCD instructions.

Select the SSID (Network Name) for your access point or router and enter the Network Key (Password).

Press and hold (or press repeatedly) **▲** or **▼** to select one of the following characters:
 0123456789abcdefghijklmnopqrstuvwxyz
 ABCDEFGHIJKLMNOPQRSTUVWXYZ
 (space)!"#\$%&'()*+,-./:;<=>?@[\] ^ _ { } ~

When the wireless setup is successful, the LCD displays [Connected].

Go to **6** to install software.

If you cannot find this information, ask your network administrator or wireless access point or router manufacturer.

If the setup is unsuccessful, restart your Brother machine and your wireless access point or router, and repeat **7**. If still unsuccessful, visit support.brother.com.