

Quick Reference Chart 1 - Preparing the bobbin thread / 快速使用指南1 - 縫紉機的線芯準備

Be sure to first read the "Safety Precautions" in the Operation Manual. This Quick Reference Chart provides information on winding and installing the bobbin. For each step in the procedure, refer to the illustration of the sewing machine in the center for an indication of the exact location of the operation. For details on the procedure, refer to "Winding/Installing the Bobbin" in the Operation Manual.

請先參閱使用說明書中的“安全注意事項”。此快速使用指南提供有關併紗及安裝線芯的方法。請參看以下縫紉機的插圖以確定每一步驟的準確位置。有關每一步驟的詳情，可參閱說明書中的“併紗及安裝線芯”之項目。

Actual size
實際尺寸

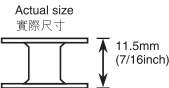

11.5mm
(7/16inch)

Prepare a specially designed bobbin.
預備一個專用的線芯。

1

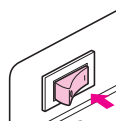

Turn on the sewing machine.
開啟電源。

2

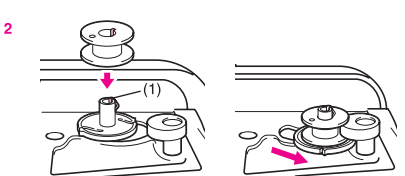

Place the bobbin on the bobbin winder shaft (1), and then slide the bobbin winder shaft to the right.
將線芯放在繞線卷軸器上(1)，再把繞線卷軸器推向右方。

3

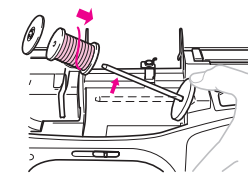

Slide the spool and spool cap onto the spool pin. • Make sure that the thread unrolls from the bottom of the spool.
把線管及線管蓋放入在線軸上。• 請確定縫紉線是由線管的最低位置開始展開。

4

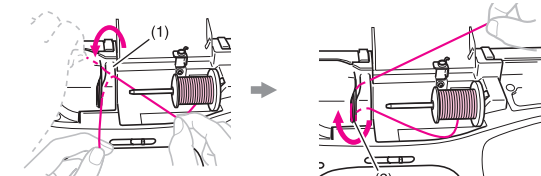

Pass the thread behind the thread guide cover 1, then under the thread guide plate (2). • Thread the sewing machine in the order indicated by the broken line on the machine.
把縫紉線繞在導線器的後面(1)，再把線拉向導線板的最下方(2)。• 必須依照畫面顯示的虛線來穿線。

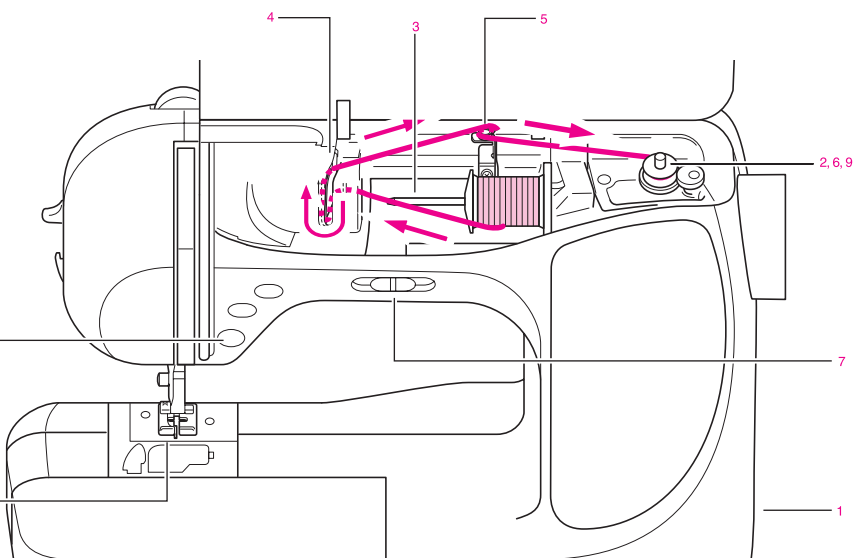

5

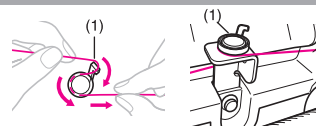

Wind the thread around the bobbin winder thread guide (1).
把縫紉線順著卷軸器的導引繼續上(1)。

6

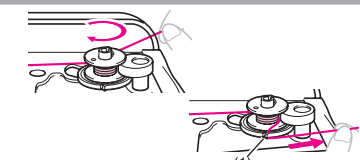

Wind the thread clockwise around the bobbin four or five times, and then cut the thread by passing it through the slit in the bobbin winder seat (1).
把縫紉線順時針方向繼續繞在線芯上大約4-5次，然後繞過繞線卷軸器旁的空隙位，把線剪斷(1)。

12

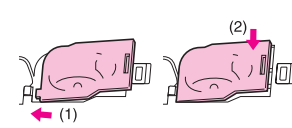

Reattach the bobbin cover.
蓋上線芯蓋。

11

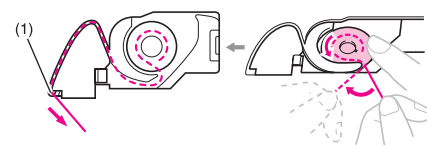

Insert the bobbin into the shuttle, pass the thread through the slot, and then cut the thread with the cutter (1). • Be sure to insert the bobbin correctly.
把線芯置入梭床內，再將線繞過滑道，然後用裁斷機把線剪斷(1)。• 請確定已正確地置入線芯。

10

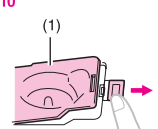

Remove the bobbin cover (1).
移出線芯蓋(1)。

9

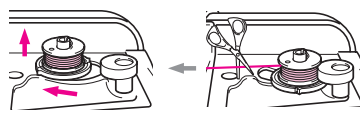

Cut the thread, slide the bobbin winder shaft to the left, and then remove the bobbin.
剪斷線後，把繞線卷軸器推向左方，拿出線芯。

8

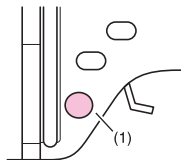

After the bobbin stops spinning, press the start/stop button (1).
當線芯停止轉動時，再按按開始/停止按鍵(1)。

7

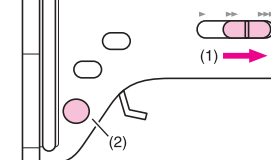

Increase the sewing speed (1), and then press the start/stop button (2).
加強縫紉速度(1)，然後按“開始/停止”鍵(2)。

See reverse.
請看背頁

Quick Reference Chart 2 - Upper Threading / 快速使用指南2 - 縫紉機的上線程序

Be sure to first read the "Safety Precautions" in the Operation Manual. This Quick Reference Chart provides information on threading the sewing machine. For each step in the procedure, refer to the illustration of the sewing machine in the center for an indication of the exact location of the operation. For details on the procedure, refer to "Upper Threading" in the Operation Manual.

請先參閱使用說明書中的“安全注意事項”。此快速使用指南提供有關穿線的方法。請參看以下縫紉機的插圖以確定每一步驟的準確位置。有關每一步驟的詳情，可參閱說明書中的“縫紉機的上線程序”之項目。

1

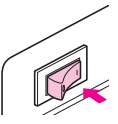

Turn on the sewing machine.
開啟電源。

2

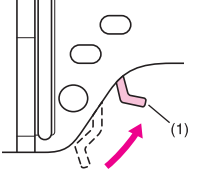

Raise the presser foot lever (1).
把壓腳的控制桿推向(1)。

3

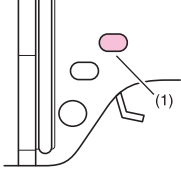

Press the needle position button (1) to raise the needle.
按控制針位置的按鍵(1)升高縫衣針。

4

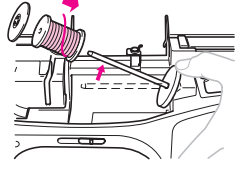

Slide the spool and spool cap onto the spool pin. I Make sure that the thread unrolls from the bottom of the spool.
把線管及線管蓋放入在線軸上。請確定線是由線管的最低位置開始展開。

5

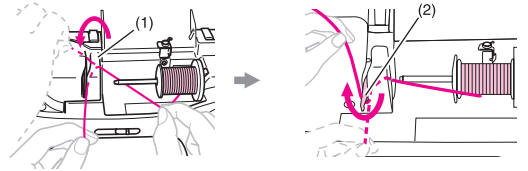

Pass the thread behind the thread guide cover (1), then under the thread guide plate (2). I Thread the sewing machine in the order indicated by the solid line on the machine.
把縫紉線繼續在導線器的後面(1)，再把線拉向導線板的最下方(2) 依照畫面顯示的實線。必須依照畫面顯示的實線來穿線。

6

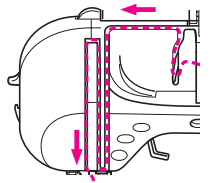

Pass the thread through the guides.
把縫紉線繞過導線板。

7

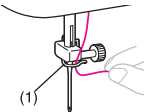

Pass the thread through the thread hook (1).
再把縫紉線繞過鉤(1)。

8

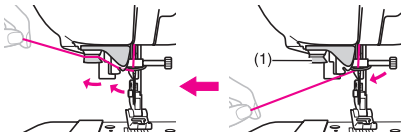

Pass the thread through the thread guide discs 1 from the front.
縫紉線必須由前方繞過導線板(1)。

9

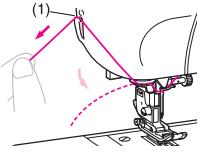

Cut the thread on the thread cutter (1).
用裁斷器把線剪斷。

10

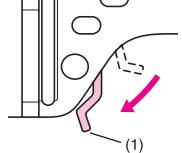

Lower the presser foot lever (1).
把壓腳的控制桿推向(1)。

11

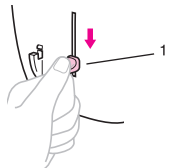

Lower the needle threader lever (1) until it clicks, and then release the lever.
按下穿針器的控制桿(1)直至聽到一聲響才放開。

12

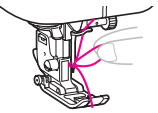

Carefully pull on the loop of thread passed through the eye of the needle.
小心地把線圈穿過針孔。

13

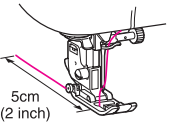

Pass the thread through the presser foot, and then pull out about 5 cm (2 inch) of thread toward the rear of the machine.
把線繞過壓腳，然後從後方拉出大約5厘米(2吋)的縫紉線。

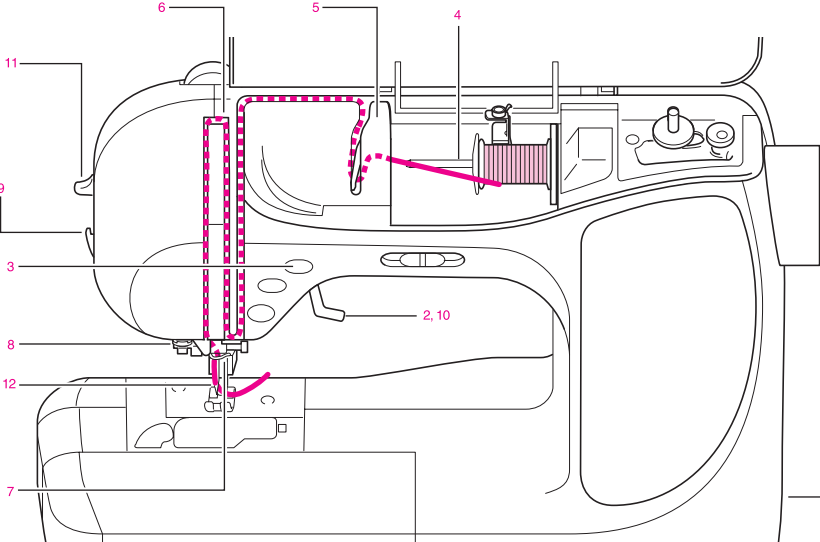

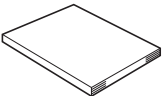

Refer to the Operation Manual for additional details.
有關其他詳情，請參閱使用說明書。