

# Quick Reference Guide

快速操作指南  
快速導覽手冊  
빠른 참조 안내서

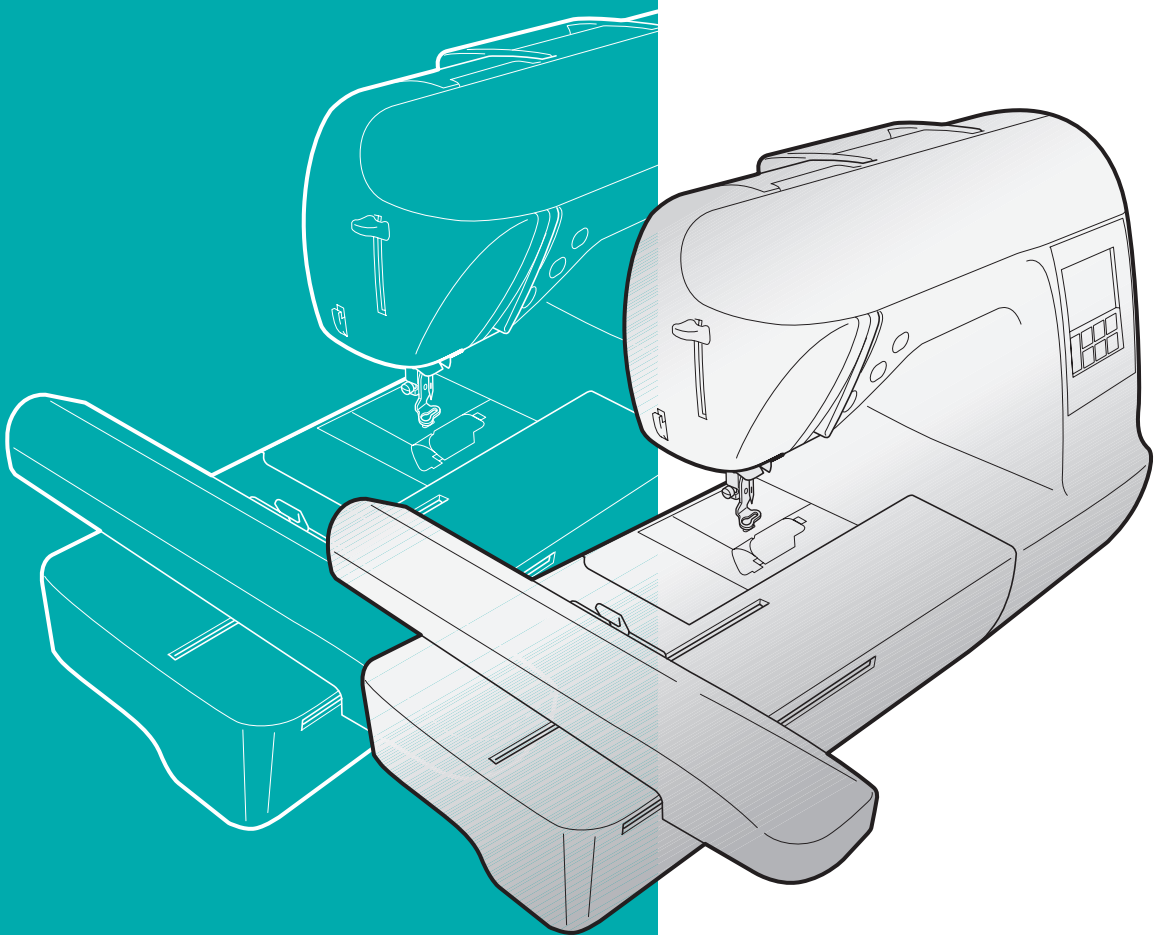

**Refer to the operation manual for detailed instruction.**

Also, there are differences in the keys and screens depending on the display language. In this guide, English screens are used for basic explanations.

有关详细说明，请参见使用说明书。

另外，按键和画面会因显示语言略有不同。在本操作指南中，使用英文画面进行基本说明。

關於詳細指示，請參閱使用說明書。

另外，不同顯示語言的按鍵及畫面會有所差異。在本說明書中，基本說明均以英文畫面為準。

자세한 내용은 작동 설명서를 참조하세요.

언어에 따라 키와 화면이 다릅니다. 이 안내서에서는 영어 화면을 기준으로 설명합니다.

## Contents

Bobbin Winding and Setting .....	2
Upper Threading.....	4
Preparing to Embroider.....	6
Selecting Embroidery Patterns .....	8
Character Patterns .....	9
Frame patterns.....	11
Embroidery Pattern Color Change Table....	12
Color Thread Conversion Chart .....	21

## 目录

梭芯绕线和设置 .....	2
面线穿线 .....	4
准备绣花 .....	6
选择绣花花样.....	8
文字花样 .....	9
框架花样 .....	11
绣花花样颜色变换表 .....	12
绣花线颜色转换表.....	21

## 目錄

捲底線裝置及設定.....	2
穿上線.....	4
準備刺繡 .....	6
選擇刺繡花樣.....	8
文字花樣 .....	9
外框花樣 .....	11
刺繡花樣顏色變換表 .....	12
繡線顏色轉換表 .....	21

## 목차

실토리 감기 및 설정.....	2
윗실 끼우기.....	4
자수 준비 .....	6
자수 패턴 선택 .....	8
문자 패턴 .....	9
테두리 패턴.....	11
자수 패턴 색 변경 표.....	12
색실 변환 차트 .....	21

# Bobbin Winding and Setting

## 梭芯绕线和设置

## 捲底線裝置及設定

## 실토리 감기 및 설정

Follow the numbered steps below in order. Refer to the operation manual for detailed instruction.

遵循下面按顺序编号的步骤。有关详细说明，请参见使用说明书。

請按照以下編號的步驟依序進行。關於詳細指示，請參閱使用說明書。

아래 번호 순서를 따르세요. 자세한 내용은 작동 설명서를 참조하세요.

Use only the enclosed bobbin or bobbins of the same type.

请务必使用随机附带的梭芯或者同类型的梭芯。

務必使用隨附的梭子或同類型的梭子。

동봉된 실토리 또는 같은 종류의 실토리만 사용하세요.

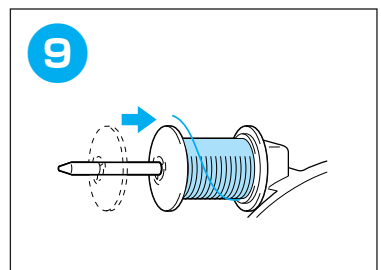
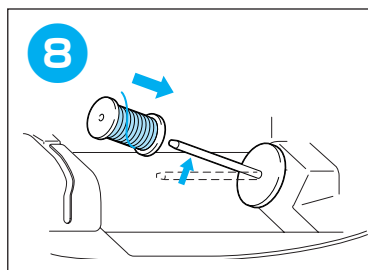
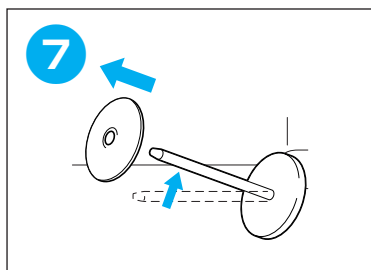
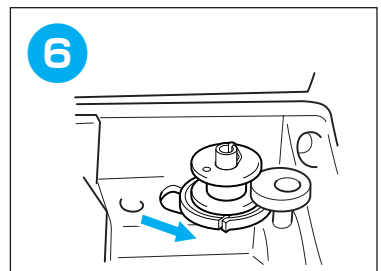
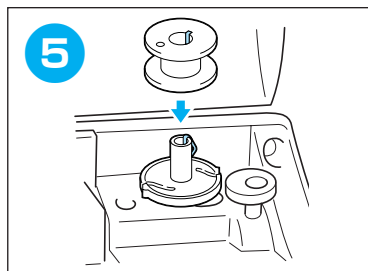
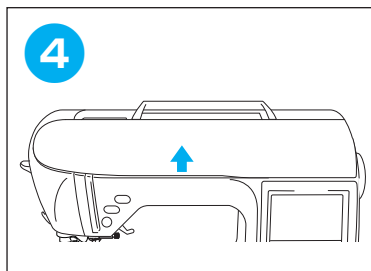
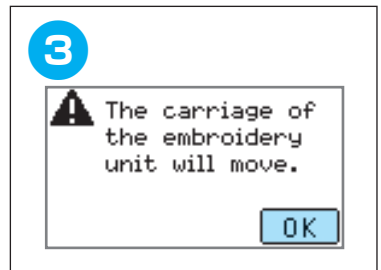
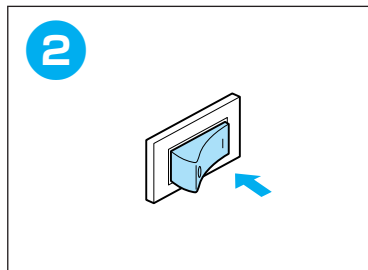
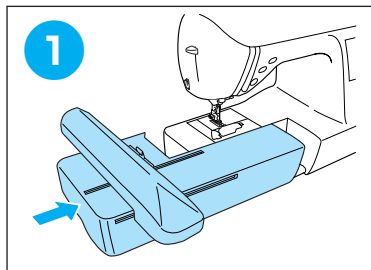
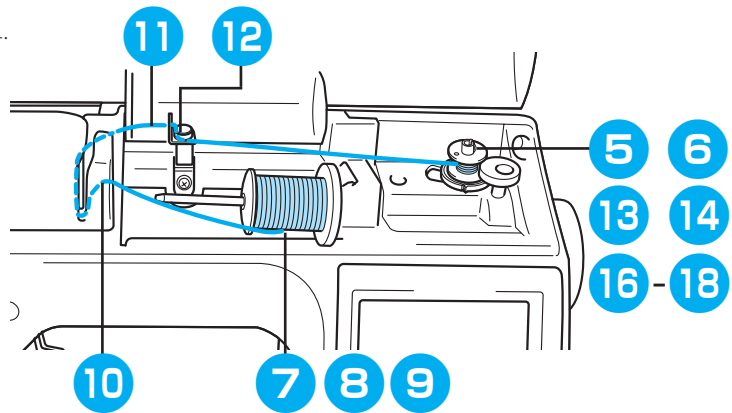
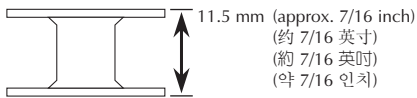

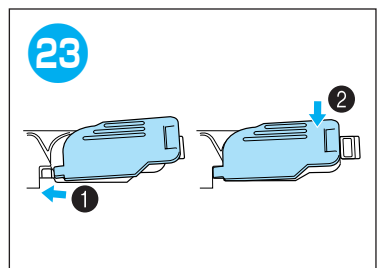
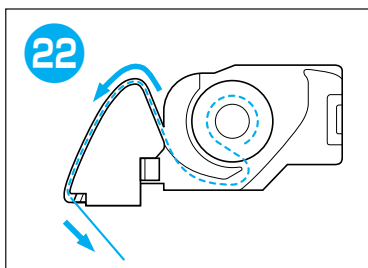
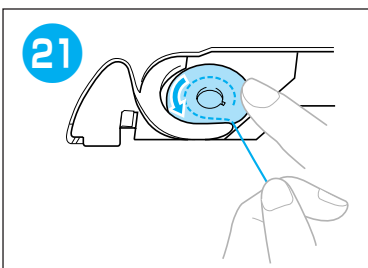
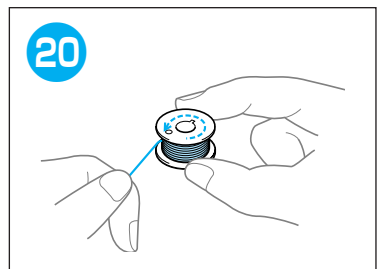
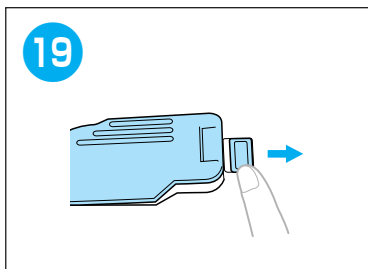
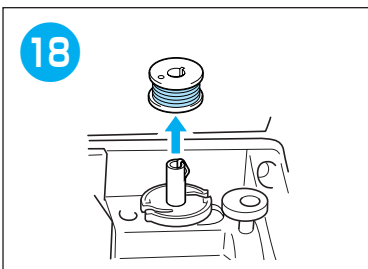
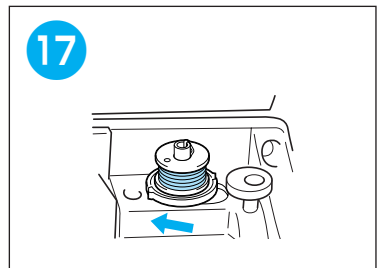
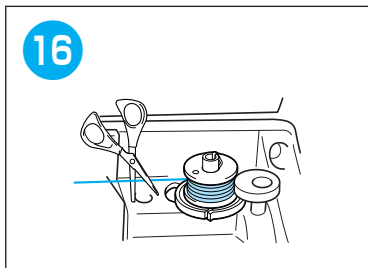
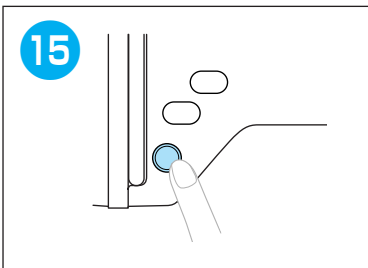
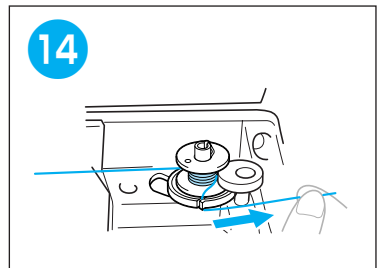
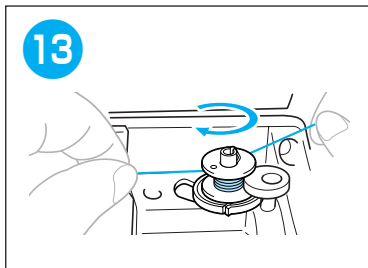
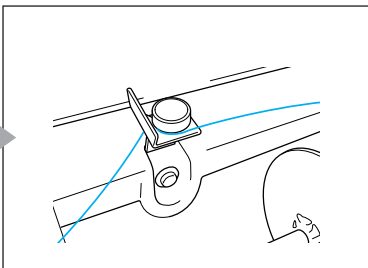
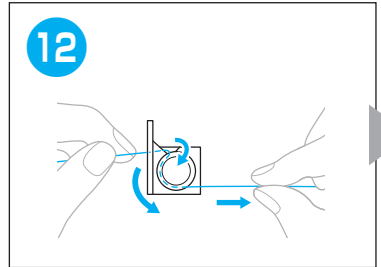
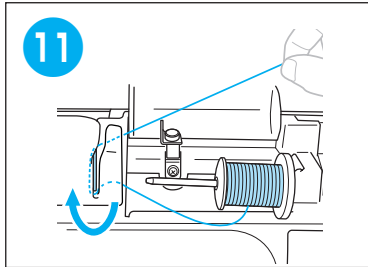
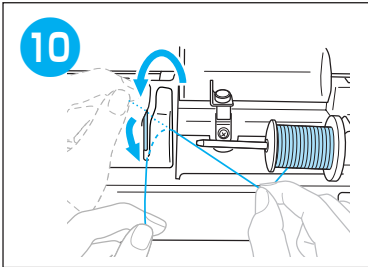

# Upper Threading

面线穿线

穿上線

윗실 끼우기

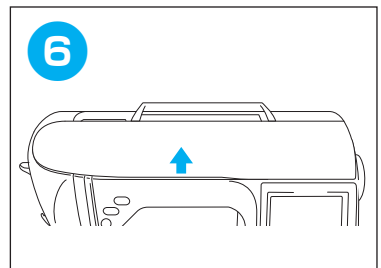
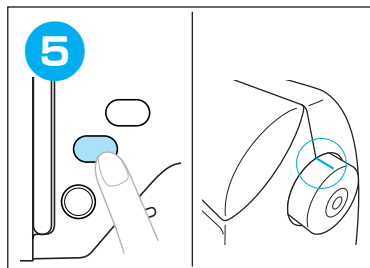
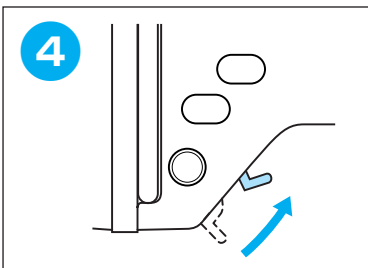
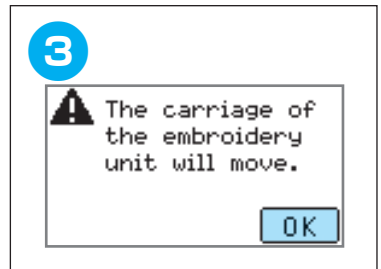
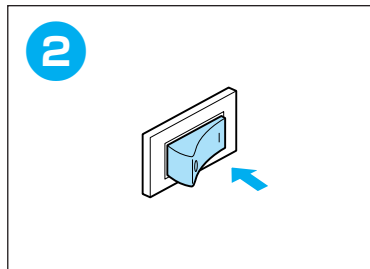
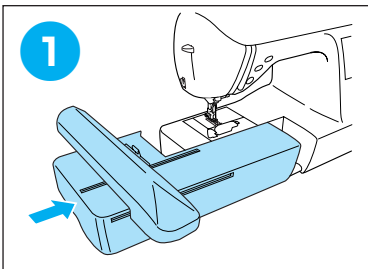
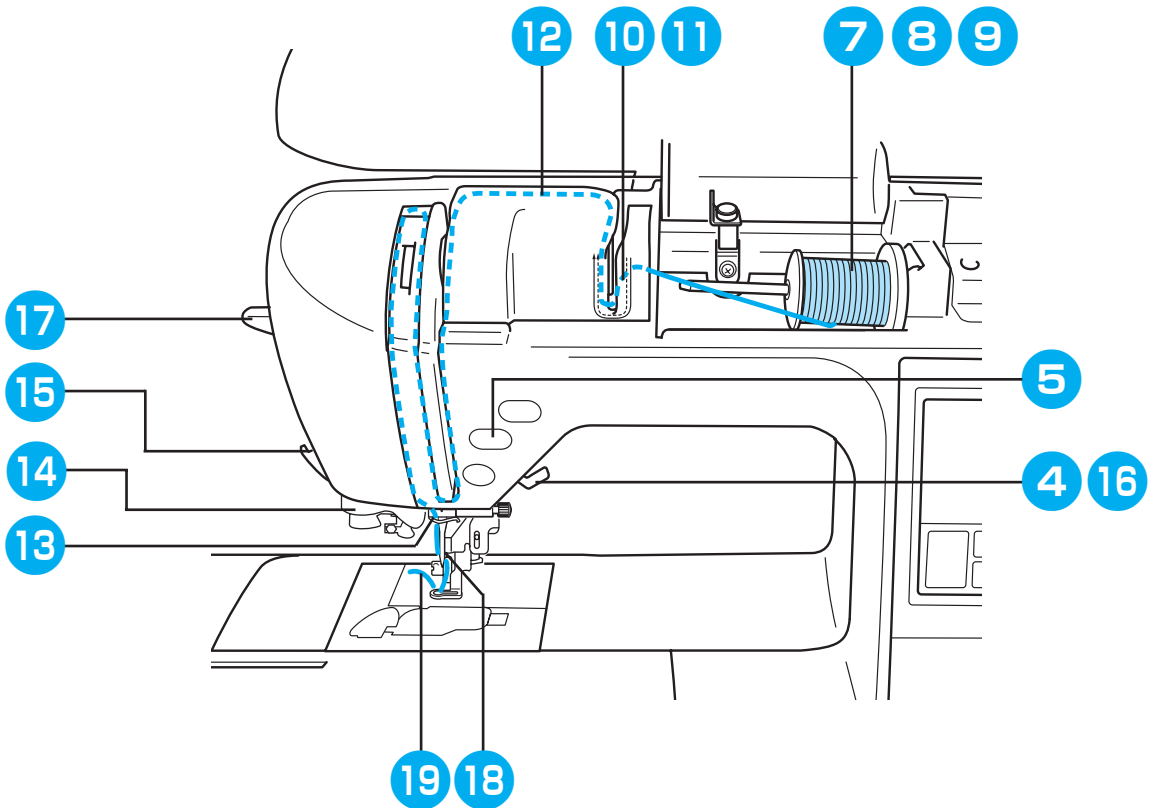

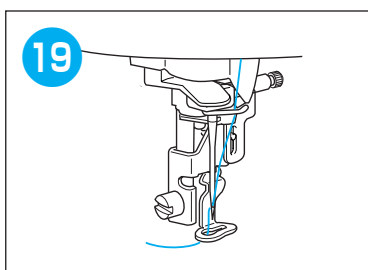
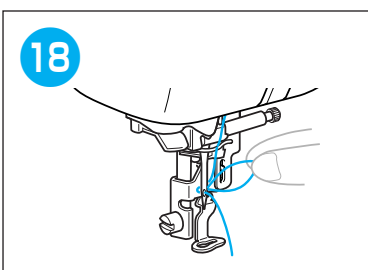
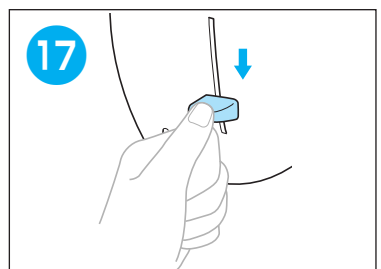
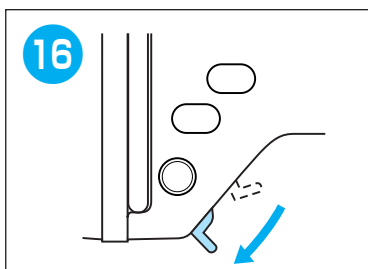
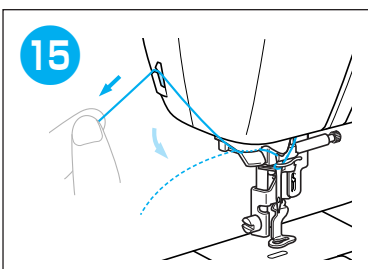
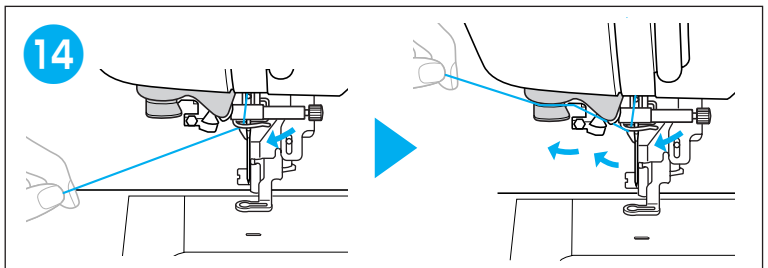
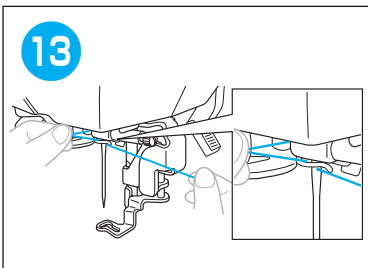
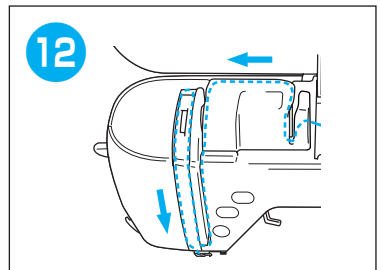
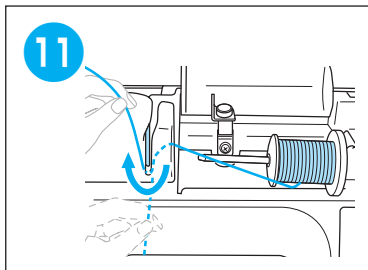
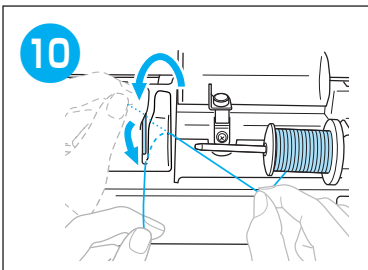
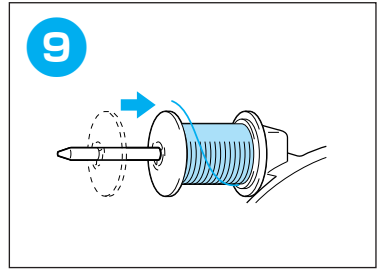
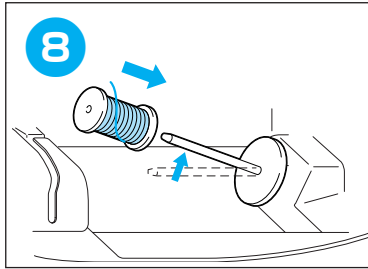
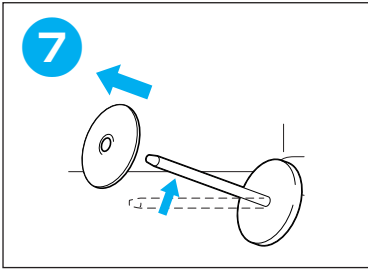

# Preparing to Embroider

准备绣花

準備刺繡

자수 준비

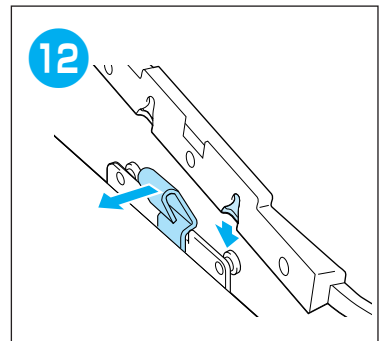
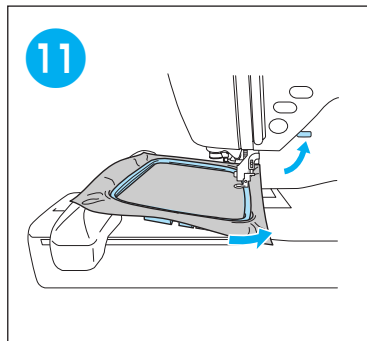
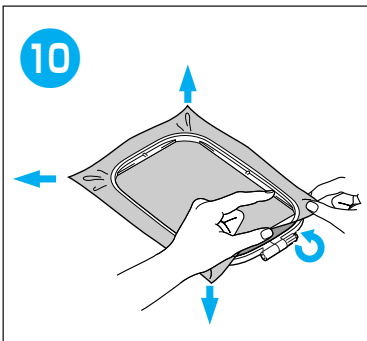
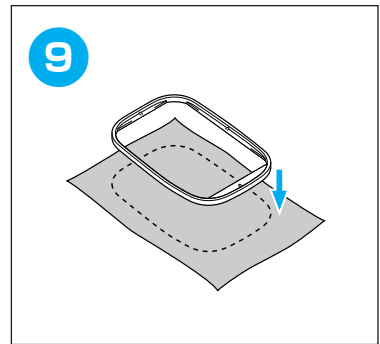
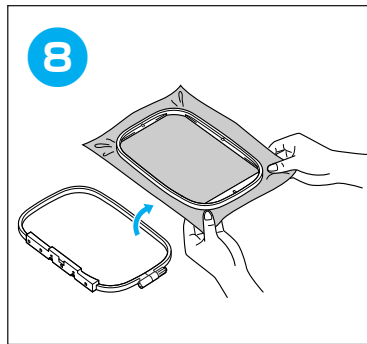
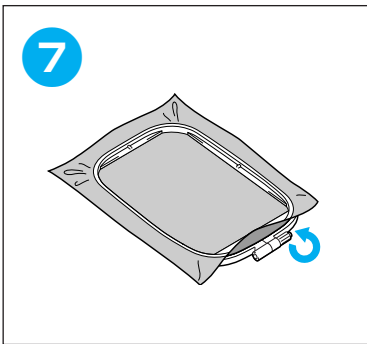
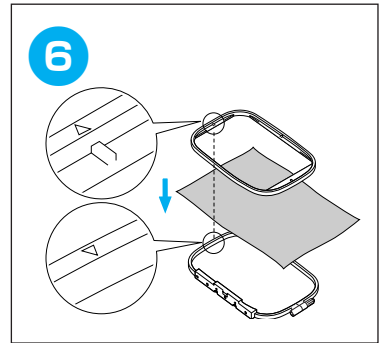
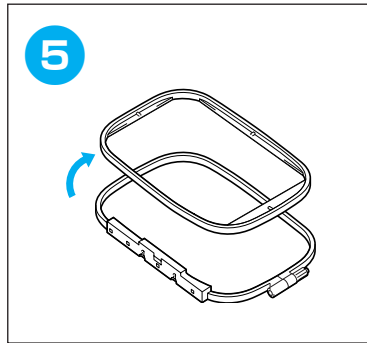
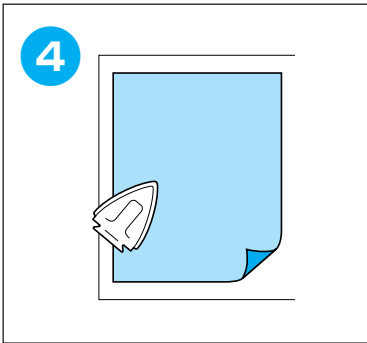
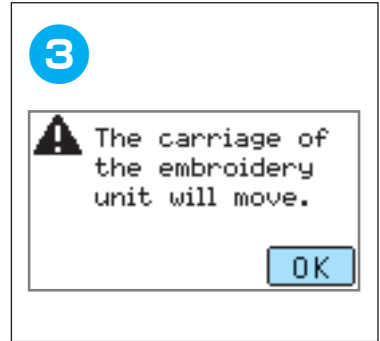
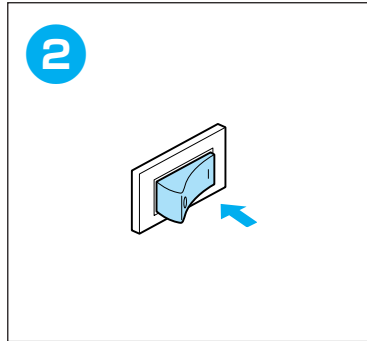
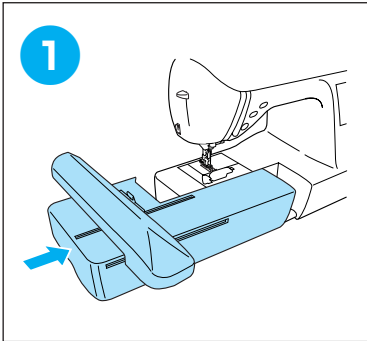



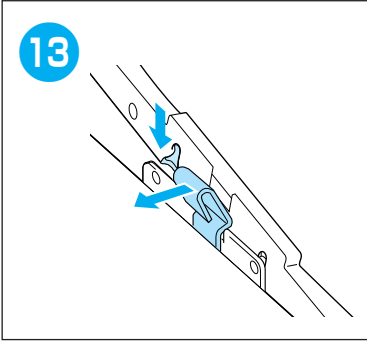

# Selecting Embroidery Patterns

选择绣花花样

選擇刺繡花樣

자수 패턴 선택

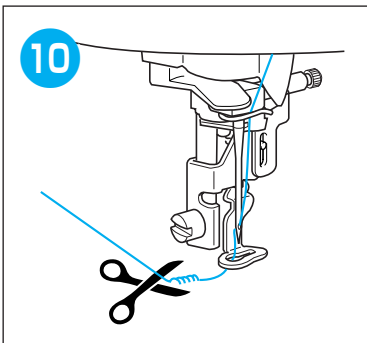
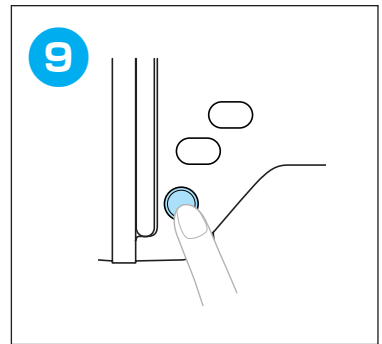
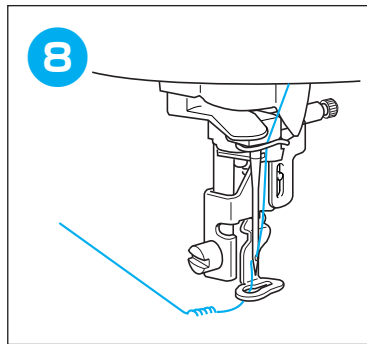
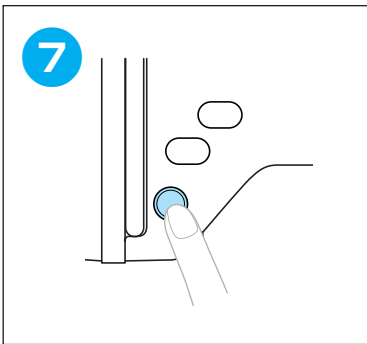
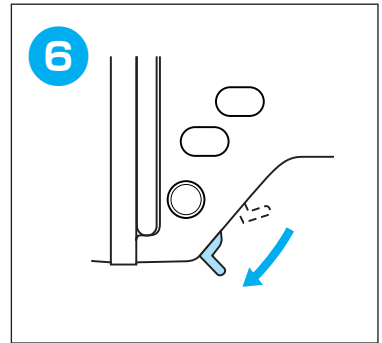
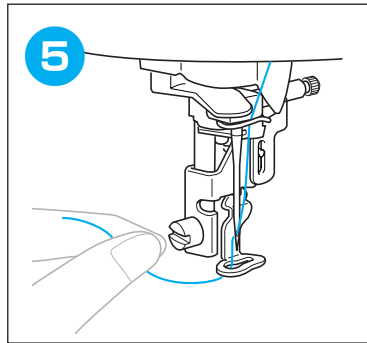
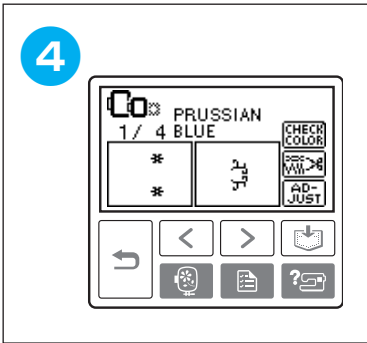
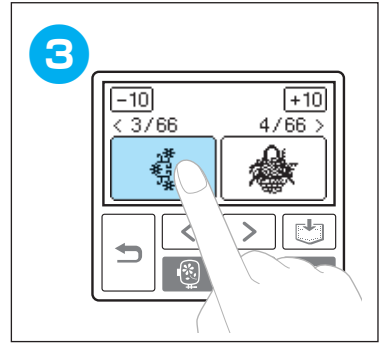
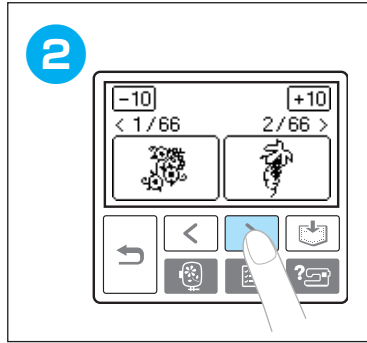
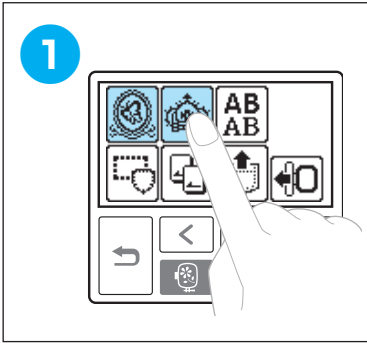

# Character Patterns

文字花样

文字花樣

문자 패턴

## ABC

A B C D E F G H I J K L M N O P Q R S  
 T U V W X Y Z  
 a b c d e f g h i j k l m n o p q r s  
 t u v w x y z  
 0 1 2 3 4 5 6 7 8 9  
 & ? ! - \_ ( ) ' . , /  
 Ä Å Æ Æ Ñ Ö Ø Ç Ü  
 ä à â â æ ë è é ê ñ ö ò ø ì ç ü ù ß

## ABC

A B C D E F G H I J K L M N O P Q R S  
 T U V W X Y Z  
 a b c d e f g h i j k l m n o p q r s  
 t u v w x y z  
 0 1 2 3 4 5 6 7 8 9  
 & ? ! - \_ ( ) ' . , /  
 Ä Å Æ Æ Ñ ö Ø Ç Ü  
 ä à â â æ ë è é ê ñ ö ò ø ì ç ü ù ß

## ABC

A B C D E F G H I J K L M N O P Q R S  
 T U V W X Y Z  
 a b c d e f g h i j k l m n o p q r s  
 t u v w x y z  
 0 1 2 3 4 5 6 7 8 9  
 & ? ! - \_ ( ) ' . , /  
 Ä Å Æ Æ Ñ ö Ø Ç Ü  
 ä à â â æ ë è é ê ñ ö ò ø ì ç ü ù ß

**ABC**

A B C D E F G H I J K L M N O P Q R S  
T U V W X Y Z  
a b c d e f g h i j k l m n o p q r s  
t u v w x y z  
0 1 2 3 4 5 6 7 8 9  
& ? ! - \_ ( ) ' . , /  
Ä Å Æ Æ Ñ Ö Ø Ç Ü  
ä å æ Æ ñ ö ø ç ü ß

**ABC**

A B C D E F G H I J K L M N O P Q R S  
T U V W X Y Z  
a b c d e f g h i j k l m n o p q r s  
t u v w x y z  
0 1 2 3 4 5 6 7 8 9  
& ? ! - \_ ( ) ' . , /  
Ä Å Æ Æ Ñ Ö Ø Ç Ü  
ä å æ Æ ñ ö ø ç ü ß

**ABC**

A B C D E F G H I J K L M N O P Q R S  
T U V W X Y Z  
a b c d e f g h i j k l m n o p q r s  
t u v w x y z  
0 1 2 3 4 5 6 7 8 9  
& ? ! - \_ ( ) ' . , /  
Ä Å Æ Æ Ñ Ö Ø Ç Ü  
ä å æ Æ ñ ö ø ç ü ß

# Frame patterns

框架花樣

外框花樣

테두리 패턴





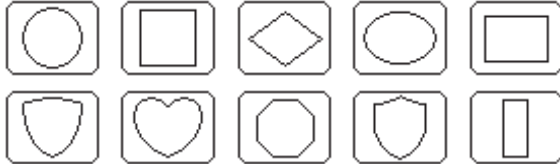



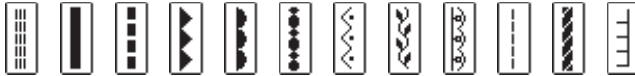

■ Frame shapes ■ 框架形狀  
 ■ 外框形狀 ■ 테두리 모양



■ Stitches ■ 針迹  
 ■ 針趾 ■ 재봉



■ Sample at actual size ■ 实际尺寸样本  
 ■ 實際尺寸樣本 ■ 실제 크기 샘플

Sample combining  and  / 組合  和  实例 /  
 結合  與  的樣本 /  +  혼합 샘플

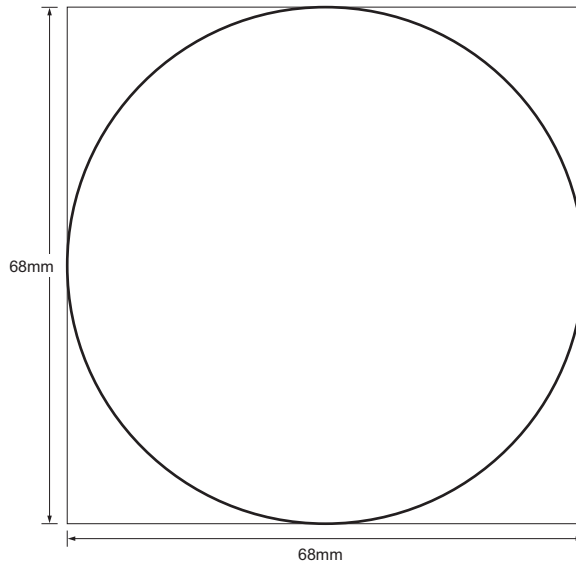



# Embroidery Pattern Color Change Table

No. 1-  
No. 70 绣花花样颜色变换表  
刺繡花樣顏色變換表  
자수 패턴 색 변경 표



No.1

8min	
1	(502)
2	(019)
3	(205)
4	(208)

Size  
↕9.5cm ↔7.1cm



No.6

4min	
1	(485)
2	(473)
3	(264)
4	(322)
5	(334)
6	(000)
7	(133)

Size  
↕2.0cm ↔9.5cm



No.11

2min	
1	(124)
2	(027)

Size  
↕3.8cm ↔4.1cm



No.2

11min	
1	(086)
2	(843)
3	(058)
4	(010)
5	(205)

Size  
↕5.7cm ↔7.7cm



No.7

8min	
1	(502)
2	(010)
3	(208)

Size  
↕7.3cm ↔6.0cm



No.12

3min	
1	(205)
2	(502)
3	(070)

Size  
↕3.6cm ↔5.2cm

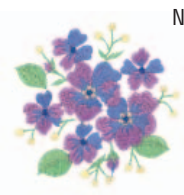

No.3

16min	
1	(502)
2	(612)
3	(070)
4	(010)
5	(007)

Size  
↕7.4cm ↔7.4cm



No.8

2min	
1	(800)
2	(507)
3	(900)

Size  
↕2.6cm ↔2.9cm



No.13

2min	
1	(810)

Size  
↕5.5cm ↔4.1cm



No.4

1min	
1	(800)
2	(507)

Size  
↕2.9cm ↔1.9cm



No.9

2min	
1	(027)
2	(810)
3	(620)

Size  
↕2.3cm ↔4.0cm



No.14

6min	
1	(804)
2	(027)
3	(804)
4	(206)

Size  
↕9.1cm ↔8.9cm



No.5

2min	
1	(507)
2	(513)
3	(205)
4	(339)

Size  
↕3.8cm ↔4.3cm



No.10

3min	
1	(534)
2	(800)
3	(307)
4	(030)

Size  
↕2.7cm ↔4.1cm



No.15

16min	
1	(513)
2	(534)
3	(612)
4	(620)
5	(070)
6	(010)

Size  
↕9.6cm ↔8.6cm

COUNTRY (C)

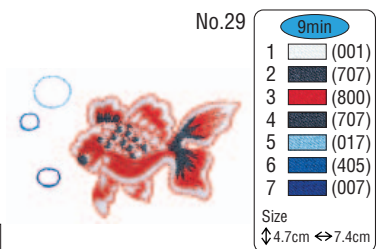
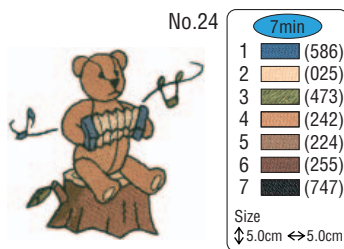
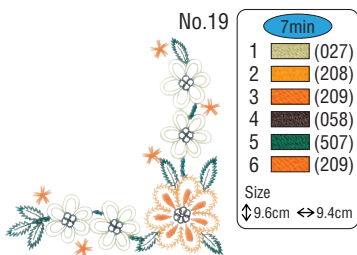
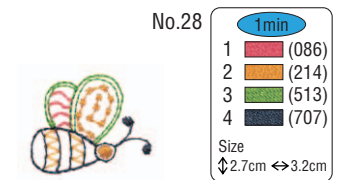
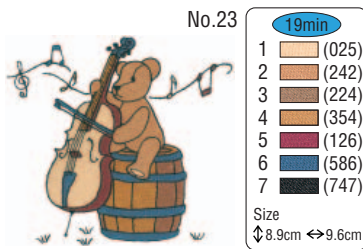
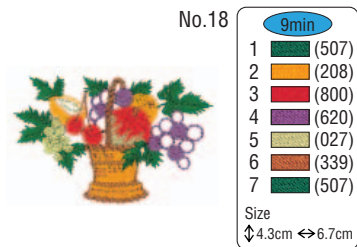
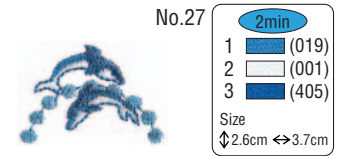
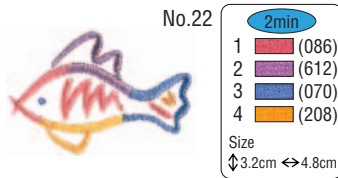
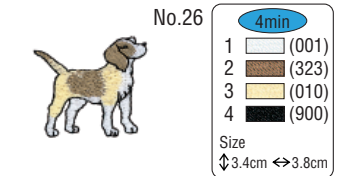
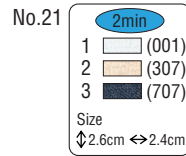
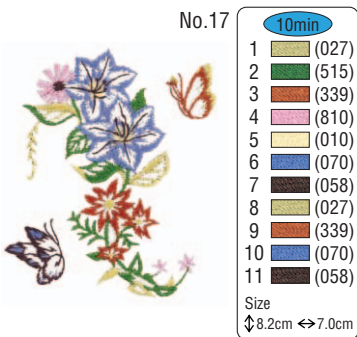
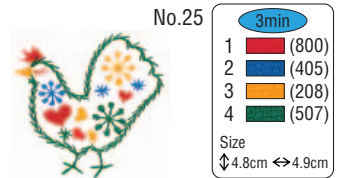
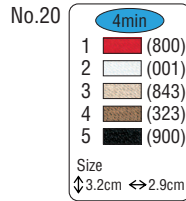
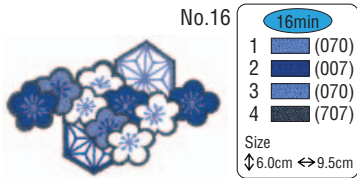

COUNTRY

COUNTRY

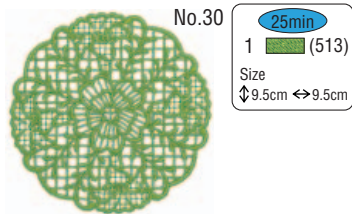

No.30

**25min**

1 (513)

Size  
 ↓9.5cm ↔9.5cm



No.35

**13min**

1 (810)

Size  
 ↓7.4cm ↔9.6cm



No.40

**21min**

1 (152)  
 2 (158)  
 3 (126)  
 4 (024)  
 5 (155)  
 6 (158)  
 7 (024)  
 8 (126)

Size  
 ↓9.5cm ↔9.5cm

COUNTRY



No.31

**4min**

1 (810)

Size  
 ↓4.8cm ↔8.5cm



No.36

**6min**

1 (019)  
 2 (405)  
 3 (019)  
 4 (208)

Size  
 ↓6.8cm ↔6.0cm



No.41

**7min**

1 (158)

Size  
 ↓15.6cm ↔12.3cm

COUNTRY



No.32

**2min**

1 (810)

Size  
 ↓3.4cm ↔3.5cm



No.37

**3min**

1 (209)  
 2 (205)  
 3 (058)  
 4 (405)  
 5 (800)

Size  
 ↓6.0cm ↔5.0cm



No.42

**2min**

1 (158)

Size  
 ↓9.4cm ↔4.2cm

COUNTRY



No.33

**3min**

1 (017)  
 2 (079)

Size  
 ↓5.7cm ↔3.8cm



No.38

**6min**

1 (586)  
 2 (575)  
 3 (706)

Size  
 ↓9.6cm ↔2.5cm

COUNTRY



No.43

**1min**

1 (620)

Size  
 ↓7.1cm ↔7.1cm



No.34

**12min**

1 (612)

Size  
 ↓9.6cm ↔6.2cm



No.39

**11min**

1 (473)  
 2 (485)  
 3 (354)  
 4 (444)  
 5 (463)

Size  
 ↓9.5cm ↔9.5cm

COUNTRY



No.44

**1min**

1 (620)

Size  
 ↓5.7cm ↔5.7cm



# Embroidery Pattern Color Change Table

绣花花样颜色变换表

刺繡花樣顏色變換表

자수 패턴 색 변경 표

No.45



8min	
1	(152)
2	(444)
3	(717)
4	(255)
5	(354)
6	(446)
7	(444)

Size  
↓7.6cm ↔8.2cm

COUNTRY

No.49

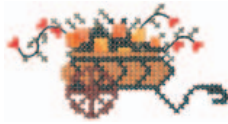

7min	
1	(334)
2	(322)
3	(335)
4	(336)
5	(473)
6	(354)
7	(485)
8	(148)
9	(255)

Size  
↓4.8cm ↔9.4cm

COUNTRY

No.53

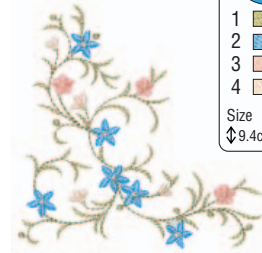

7min	
1	(027)
2	(017)
3	(124)
4	(307)

Size  
↓9.4cm ↔9.5cm

No.46

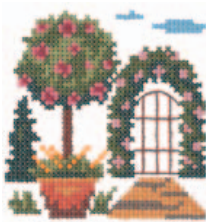

19min	
1	(706)
2	(354)
3	(264)
4	(122)
5	(133)
6	(335)
7	(444)
8	(446)
9	(485)
10	(126)
11	(255)
12	(512)

Size  
↓9.2cm ↔9.0cm

COUNTRY

No.50



2min	
1	(149)
2	(370)
3	(334)
4	(133)
5	(624)
6	(322)
7	(717)
8	(485)

Size  
↓2.8cm ↔5.4cm

COUNTRY

No.54



2min	
1	(027)
2	(124)
3	(017)
4	(307)

Size  
↓3.0cm ↔9.4cm

No.47



11min	
1	(025)
2	(224)
3	(473)
4	(155)
5	(485)
6	(149)

Size  
↓9.4cm ↔8.2cm

COUNTRY

No.51

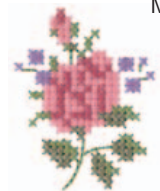

4min	
1	(024)
2	(152)
3	(444)
4	(473)
5	(623)

Size  
↓5.3cm ↔4.0cm

COUNTRY

No.55



3min	
1	(079)
2	(124)

Size  
↓4.6cm ↔3.2cm

No.48



5min	
1	(446)
2	(335)
3	(404)

Size  
↓9.0cm ↔5.8cm

COUNTRY

No.52



1min	
1	(025)
2	(155)
3	(483)
4	(158)

Size  
↓1.6cm ↔2.2cm

COUNTRY

No.56



3min	
1	(208)
2	(612)
3	(010)
4	(027)
5	(206)
6	(058)

Size  
↓2.9cm ↔3.8cm

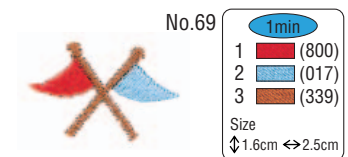
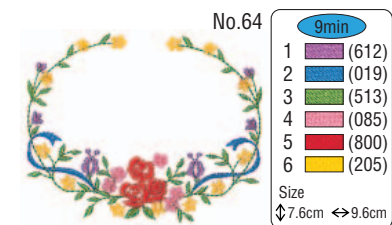
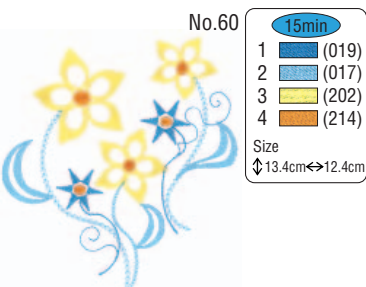
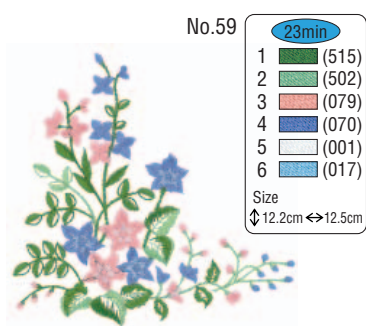
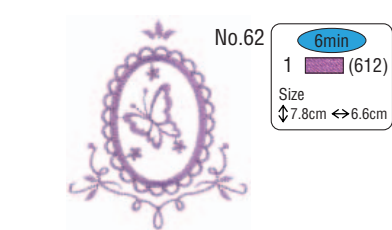
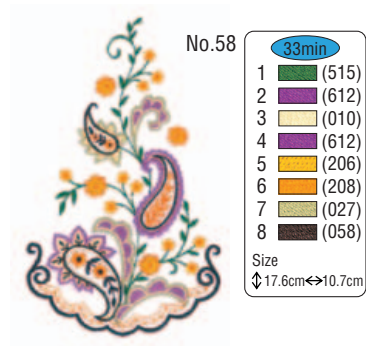
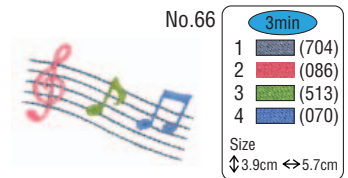
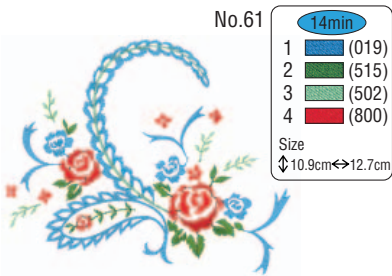
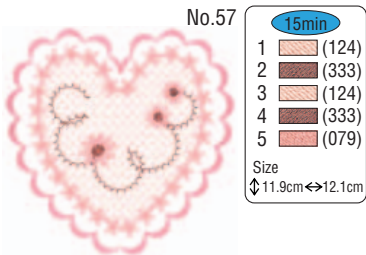



# Embroidery Pattern Color Change Table

No. 1-  
No. 66 绣花花样颜色变换表  
刺繡花樣顏色變換表  
자수 패턴 색 변경 표

No.1

7min

1	(206)
2	(027)
3	(804)
4	(812)

Size  
↓6.4cm ↔ 6.6cm

No.7

25min

1	(473)
2	(444)
3	(463)
4	(473)
5	(354)
6	(158)
7	(322)
8	(336)
9	(264)
10	(322)
11	(336)
12	(264)
13	(444)
14	(706)

Size  
↓9.6cm ↔ 9.4cm

COUNTRY (C)

No.12

3min

1	(070)
2	(607)
3	(070)

Size  
↓9.6cm ↔ 3.0cm

No.2

4min

1	(070)
---	-------

Size  
↓7.9cm ↔ 4.7cm

No.8

5min

1	(007)
---	-------

Size  
↓4.6cm ↔ 8.5cm

No.13

3min

1	(476)
2	(126)
3	(024)
4	(122)

Size  
↓8.1cm ↔ 1.6cm

COUNTRY (C)

No.3

2min

1	(007)
2	(405)
3	(800)
4	(070)

Size  
↓5.2cm ↔ 2.9cm

No.4

4min

1	(323)
2	(507)
3	(800)
4	(214)

Size  
↓2.8cm ↔ 3.2cm

No.9

3min

1	(007)
---	-------

Size  
↓3.9cm ↔ 8.1cm

No.14

4min

1	(328)
2	(323)
3	(612)
4	(208)

Size  
↓2.2cm ↔ 9.6cm

No.5

2min

1	(019)
---	-------

Size  
↓2.2cm ↔ 4.3cm

No.10

2min

1	(214)
---	-------

Size  
↓3.0cm ↔ 5.7cm

No.6

4min

1	(079)
---	-------

Size  
↓4.9cm ↔ 6.6cm

No.11

5min

1	(214)
2	(019)
3	(027)

Size  
↓5.2cm ↔ 5.2cm

No.15

9min

1	(328)
2	(323)
3	(612)
4	(208)

Size  
↓9.6cm ↔ 9.6cm



No.16

23min

1	(515)
2	(405)
3	(019)
4	(704)
5	(007)

Size  
 ↓ 16.4cm ↔ 9.9cm



No.20

3min

1	(158)
---	-------

Size  
 ↓ 7.1cm ↔ 8.7cm

COUNTRY



No.17

15min

1	(507)
2	(620)
3	(019)
4	(405)
5	(209)
6	(800)

Size  
 ↓ 15.7cm ↔ 7.2cm



No.21

4min

1	(086)
---	-------

Size  
 ↓ 7.1cm ↔ 4.5cm



No.22

9min

1	(001)
2	(208)
3	(017)
4	(612)
5	(070)
6	(707)
7	(900)

Size  
 ↓ 3.9cm ↔ 5.7cm



No.18

18min

1	(323)
2	(502)
3	(515)
4	(079)
5	(085)
6	(208)

Size  
 ↓ 13.6cm ↔ 10.0cm



No.23

18min

1	(513)
2	(001)
3	(323)
4	(800)
5	(017)
6	(810)
7	(900)
8	(513)
9	(001)
10	(323)
11	(019)
12	(070)
13	(900)
14	(058)
15	(502)
16	(704)
17	(900)

Size  
 ↓ 9.6cm ↔ 6.5cm



No.19

7min

1	(017)
---	-------

Size  
 ↓ 5.9cm ↔ 8.3cm



No.24

1min

1	(612)
---	-------















Size  
 ↓ 5.8cm ↔ 9.4cm

# Embroidery Pattern Color Change Table

绣花花样颜色变换表

刺繡花樣顏色變換表

자수 패턴 색 변경 표



























 <p><b>No.25</b></p> <p>1 (612)</p> <p>Size ↓17.6cm ↔ 5.7cm</p>	 <p><b>No.30</b></p> <p>1 (604) 2 (334) 3 (155)</p> <p>Size ↓5.8cm ↔ 3.6cm</p> <p>COUNTRY</p>	 <p><b>No.36</b></p> <p>1 (507) 2 (208) 3 (001) 4 (307) 5 (800) 6 (339)</p> <p>Size ↓4.2cm ↔ 4.9cm</p>
 <p><b>No.26</b></p> <p>1 (612)</p> <p>Size ↓12.6cm ↔ 12.6cm</p>	 <p><b>No.31</b></p> <p>1 (800) 2 (001) 3 (900) 4 (019) 5 (205) 6 (323)</p> <p>Size ↓3.0cm ↔ 2.1cm</p>	 <p><b>No.37</b></p> <p>1 (800) 2 (030) 3 (507) 4 (070) 5 (005) 6 (070) 7 (900) 8 (328)</p> <p>Size ↑5.5cm ↔ 9.3cm</p>
 <p><b>No.27</b></p> <p>1 (070) 2 (079)</p> <p>Size ↓6.9cm ↔ 6.3cm</p>	 <p><b>No.32</b></p> <p>1 (005) 2 (323) 3 (058) 4 (900) 5 (323) 6 (005)</p> <p>Size ↓2.9cm ↔ 2.9cm</p>	 <p><b>No.38</b></p> <p>1 (586) 2 (485) 3 (473) 4 (149) 5 (334)</p> <p>Size ↓5.5cm ↔ 9.0cm</p> <p>COUNTRY</p>
 <p><b>No.28</b></p> <p>1 (323)</p> <p>Size ↓10.0cm ↔ 6.5cm</p>	 <p><b>No.33</b></p> <p>1 (704)</p> <p>Size ↓2.3cm ↔ 3.0cm</p>	 <p><b>No.39</b></p> <p>1 (588) 2 (000) 3 (126) 4 (024) 5 (255) 6 (354) 7 (586)</p> <p>Size ↓3.4cm ↔ 8.1cm</p> <p>COUNTRY</p>
 <p><b>★ No.29</b></p> <p>1 (086) 2 (086) 3 (086) 4 (328)</p> <p>Size ↓4.9cm ↔ 4.8cm</p>	 <p><b>No.34</b></p> <p>1 (001) 2 (405) 3 (017) 4 (800)</p> <p>Size ↓3.2cm ↔ 3.3cm</p>	 <p><b>No.40</b></p> <p>1 (507) 2 (007) 3 (405) 4 (810) 5 (085) 6 (001) 7 (800) 8 (900) 9 (208)</p> <p>Size ↓9.6cm ↔ 6.3cm</p>

★ Refer to the operation manual for the embroidery machine for details on how to embroider appliqués.

★ 有关如何绣制贴布绣的详细信息，请参见绣花机的使用说明书。

★ 關於詳細資訊以及如何進行貼布繡，請參閱縫紉機的使用說明書。

★ 자세한 아플리케 자수 방법은 재봉기 작동 설명서를 참조하세요.

	<p>No.41</p> <p>1min</p> <p>1 (070)</p> <p>Size</p> <p>↕3.1cm ↔3.9cm</p>		<p>No.50</p> <p>1min</p> <p>1 (070)</p> <p>Size</p> <p>↕4.5cm ↔3.1cm</p>		<p>No.59</p> <p>1min</p> <p>1 (070)</p> <p>Size</p> <p>↕3.1cm ↔2.9cm</p>
	<p>No.42</p> <p>2min</p> <p>1 (070)</p> <p>Size</p> <p>↕3.1cm ↔3.6cm</p>		<p>No.51</p> <p>1min</p> <p>1 (070)</p> <p>Size</p> <p>↕3.1cm ↔4.0cm</p>		<p>No.60</p> <p>1min</p> <p>1 (070)</p> <p>Size</p> <p>↕3.4cm ↔3.4cm</p>
	<p>No.43</p> <p>1min</p> <p>1 (070)</p> <p>Size</p> <p>↕3.1cm ↔2.9cm</p>		<p>No.52</p> <p>1min</p> <p>1 (070)</p> <p>Size</p> <p>↕3.1cm ↔3.1cm</p>		<p>No.61</p> <p>2min</p> <p>1 (070)</p> <p>Size</p> <p>↕3.1cm ↔3.7cm</p>
	<p>No.44</p> <p>2min</p> <p>1 (070)</p> <p>Size</p> <p>↕3.1cm ↔3.1cm</p>		<p>No.53</p> <p>2min</p> <p>1 (070)</p> <p>Size</p> <p>↕3.1cm ↔4.6cm</p>		<p>No.62</p> <p>1min</p> <p>1 (070)</p> <p>Size</p> <p>↕3.1cm ↔3.5cm</p>
	<p>No.45</p> <p>1min</p> <p>1 (070)</p> <p>Size</p> <p>↕3.1cm ↔2.8cm</p>		<p>No.54</p> <p>1min</p> <p>1 (070)</p> <p>Size</p> <p>↕3.1cm ↔4.3cm</p>		<p>No.63</p> <p>2min</p> <p>1 (070)</p> <p>Size</p> <p>↕3.1cm ↔5.3cm</p>
	<p>No.46</p> <p>2min</p> <p>1 (070)</p> <p>Size</p> <p>↕3.5cm ↔3.2cm</p>		<p>No.55</p> <p>1min</p> <p>1 (070)</p> <p>Size</p> <p>↕3.1cm ↔2.6cm</p>		<p>No.64</p> <p>1min</p> <p>1 (070)</p> <p>Size</p> <p>↕3.1cm ↔3.8cm</p>
	<p>No.47</p> <p>1min</p> <p>1 (070)</p> <p>Size</p> <p>↕3.1cm ↔2.4cm</p>		<p>No.56</p> <p>1min</p> <p>1 (070)</p> <p>Size</p> <p>↕3.1cm ↔3.2cm</p>		<p>No.65</p> <p>1min</p> <p>1 (070)</p> <p>Size</p> <p>↕3.1cm ↔2.9cm</p>
	<p>No.48</p> <p>1min</p> <p>1 (070)</p> <p>Size</p> <p>↕3.2cm ↔4.2cm</p>		<p>No.57</p> <p>1min</p> <p>1 (070)</p> <p>Size</p> <p>↕3.1cm ↔2.6cm</p>		<p>No.66</p> <p>1min</p> <p>1 (070)</p> <p>Size</p> <p>↕4.5cm ↔3.3cm</p>
	<p>No.49</p> <p>1min</p> <p>1 (070)</p> <p>Size</p> <p>↕3.1cm ↔2.7cm</p>		<p>No.58</p> <p>2min</p> <p>1 (070)</p> <p>Size</p> <p>↕3.1cm ↔3.7cm</p>		

# Color Thread Conversion Chart

## 繡線顏色轉換表

# 绣花线颜色转换表

## 색실 변환 차트

	Color Name	Embroidery	Country	Madeira Polyneon	Madeira Rayon	Sulky	R.A. Polyester
1	Black / 黑色 / 黒 / 검정색	 900	 100	1800	1000	1005	5596
2	White / 白色 / 白 / 흰색	 001	 000	1801	1002	1001	5597
3	Red / 红色 / 紅 / 빨강색	 800	 149	1637	1037	1037	5678
4	Pink / 粉红色 / 粉 / 핑크색	 085	 155	1921	1108	1224	5523
5	Deep Rose / 深玫红 / 深玫瑰 / 담홍색	 086	 024	1721	1117	1154	9168
6	Flesh Pink / 肉粉色 / 淡粉 / 연핑크	 124	 152	1915	1015	1064	5677
7	Dark Fuchsia / 深紫红 / 深桃紅 / 어두운 핑크	 107	 126	1984	1383	1533	5804
8	Vermillion / 朱红色 / 朱紅 / 주홍색	 030	 148	1779	1179	1184	9023
9	Carmine / 洋红色 / 胭脂紅 / 진홍색	 807	 158	1986	1081	1511	5561
10	Royal Purple / 蓝紫色 / 皇家紫 / 청자주	 869	 636	1788	1188	1192	5681
11	Magenta / 品红 / 紅紫 / 자홍색	 620	 625	1710	1319	1191	5592
12	Salmon Pink / 橙红色 / 橙紅 / 밝은 주황	 079	 122	1816	1317	1225	5773
13	Amber Red / 琥珀红 / 琥珀紅 / 짙은 적갈색	 333	 212	1942	1341	1119	5591
14	Lemon Yellow / 柠檬黄 / 檸檬黃 / 레몬색	 202	 342	1623	1023	1067	5625
15	Yellow / 黄色 / 黃 / 노란색	 205	 043	1980	1068	1187	5860
16	Harvest Gold / 金黄色 / 金 / 황금색	 206	 334	1971	1024	1124	5770
17	Orange / 橙色 / 橘 / 주황색	 208	 335	1951	1137	1024	5694
18	Pumpkin / 南瓜色 / 南瓜色 / 호박색	 126	 322	1952	1155	1065	5630
19	Tangerine / 橘子色 / 蜜桔橘 / 다홍색	 209	 336	1965	1078	1078	5518
20	Cream Brown / 乳褐色 / 奶油棕 / 담황색	 010	 331	1866	1022	1061	5761
21	Cream Yellow / 乳黄色 / 奶油黃 / 연노랑	 812	 370	1861	1349	1135	5564
22	Khaki / 卡其色 / 卡其色 / 카키색	 348	 242	1939	1255	1055	5636
23	Deep Gold / 深黄色 / 深金 / 황토색	 214	 354	1772	1172	1025	5770
24	Brass / 黄铜色 / 黃銅色 / 황동색	 328	 404	1791	1192	1159	9109
25	Linen / 亚麻色 / 亞麻色 / 살색	 307	 025	1682	1149	1082	5635
26	Dark Brown / 深褐色 / 深棕 / 암갈색	 058	 717	1859	1130	1129	5637
27	Reddish Brown / 红褐色 / 紅棕 / 적갈색	 337	 264	1753	1253	1021	5781
28	Clay Brown / 土棕褐色 / 土棕褐 / 흙갈색	 339	 224	1621	1021	1158	5590
29	Beige / 米黄色 / 米色 / 베이지색	 843	 012	1738	1138	1127	5598
30	Warm Gray / 暖灰色 / 暖灰 / 연회색	 399	 706	1860	1085	1218	9126
31	Russet Brown / 赤褐色 / 黃褐棕 / 황갈색	 330	 414	1726	1194	1126	5702
32	Light Brown / 浅棕色 / 淺棕 / 연갈색	 323	 255	1729	1056	1128	5789
33	Seacrest / 蓝绿色 / 青瓷色 / 청자색	 542	 505	1647	1219	1077	5578
34	Mint Green / 薄荷绿 / 薄荷綠 / 민트 그린	 502	 461	1702	1302	1047	5511
35	Leaf Green / 叶绿色 / 黃 / 연녹색	 509	 463	1749	1050	1510	5514
36	Olive Green / 橄榄绿 / 橄欖綠 / 올리브 그린	 519	 476	1904	1396	1174	5502
37	Dark Olive / 深橄榄色 / 暗橄欖綠 / 암녹색	 517	 473	1769	1156	1156	9122
38	Teal Green / 青绿色 / 深青綠 / 청녹색	 534	 483	1879	1298	1503	5751
39	Emerald Green / 翡翠绿 / 鮮綠 / 선녹색	 507	 485	1750	1250	1079	5508
40	Deep Green / 深绿色 / 深綠 / 진녹색	 808	 467	1703	1370	1208	5615

