

Operation keys and LCD
Teclas de operación y pantalla de LCD

Touches de fonctionnement et écran à cristaux liquides
Teclas de operação e LCD

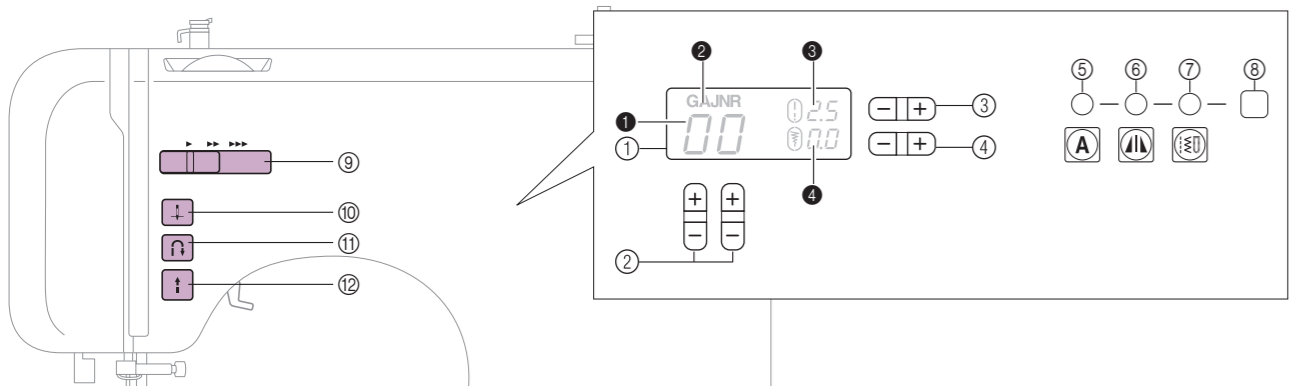

- | | | | |
|---------------------------------------|---|---|--|
| ① LCD (liquid crystal display) | ① Écran à cristaux liquides | ① LCD (pantalla de cristal líquido) | ① LCD (tela de cristal líquido) |
| ② Number of the selected stitch | ② Numéro du point sélectionné | ② Número de la puntada seleccionada | ② Número do ponto selecionado |
| ③ Presser foot to be used | ③ Pied-de-biche à utiliser | ③ Pie prensatela que se va a utilizar | ③ Calçador a ser utilizado |
| ④ Stitch length (mm) | ④ Longueur du point (mm) | ④ Longitud de la puntada (mm) | ④ Comprimento do ponto (mm) |
| ⑤ Stitch width (mm) | ⑤ Largeur du point (mm) | ⑤ Anchura de la puntada (mm) | ⑤ Largura do ponto (mm) |
| ② Stitch selection keys | ② Touches de sélection de point | ② Teclas de selección de puntada | ② Teclas de seleção de ponto |
| ③ Stitch length adjustment key | ③ Touche de réglage de la longueur du point | ③ Tecla de ajuste de longitud de la puntada | ③ Tecla de ajuste do comprimento do ponto |
| ④ Stitch width adjustment key | ④ Touche de réglage de la largeur du point | ④ Tecla de ajuste de anchura de la puntada | ④ Tecla de ajuste da largura do ponto |
| ⑤ Character stitch indicator | ⑤ Témoin de point de caractère | ⑤ Indicador de puntada con caracteres | ⑤ Indicador do ponto de letras do alfabeto |
| ⑥ Mirror image stitch indicator | ⑥ Témoin de point en image miroir | ⑥ Indicador de puntada imagen en espejo | ⑥ Indicador do ponto de imagem espelhada |
| ⑦ Utility stitch indicator | ⑦ Témoin de point utilitaire | ⑦ Indicador de puntada con aplicaciones | ⑦ Indicador do ponto utilitário |
| ⑧ Stitch category selection key | ⑧ Touche de sélection de catégorie de point | ⑧ Tecla de selección de la categoría de puntada | ⑧ Tecla de seleção da categoria do ponto |
| ⑨ Sewing speed controller | ⑨ Commande de vitesse de couture | ⑨ Controlador de velocidade de costura | ⑨ Controlador da velocidade de costura |
| ⑩ Needle position button | ⑩ Touche Positionnement d'aiguille | ⑩ Botón de Posición de aguja | ⑩ Botão da posição da agulha |
| ⑪ Reverse/reinforcement stitch button | ⑪ Touche Point inverse/renfort | ⑪ Botón de Costura en reversa/remate | ⑪ Botão do ponto reverso/de reforço |
| ⑫ Start/stop button | ⑫ Touche Marche/Arrêt | ⑫ Botón de Inicio/parar | ⑫ Botão de início/parada |

Selecting a stitch
Selección de una puntada

Sélection d'un point
Seleção de um ponto

Example: (04)
Ejemplo: (04)

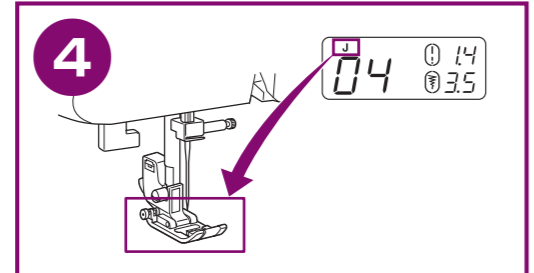
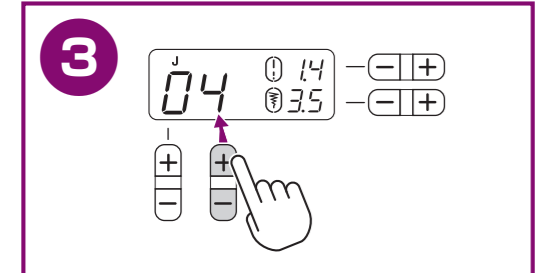
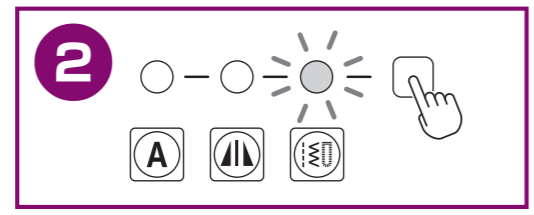
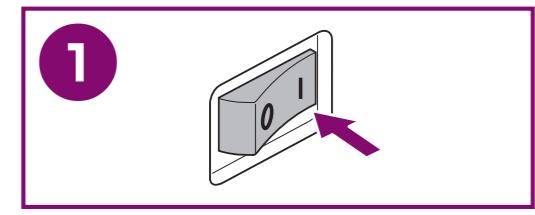

Refer to the Operation Manual for detailed instructions about sewing.
Reportez-vous au Manuel d'instructions pour des directives de couture plus détaillées.
Consultar el Manual de instrucciones detalladas acerca de la costura.
Consulte o Manual de Operações para obter instruções detalhadas sobre costura.

1

Preparing the bobbin thread
Preparación del hilo de la bobina

Préparation du fil de la canette
Preparação da linha da bobina

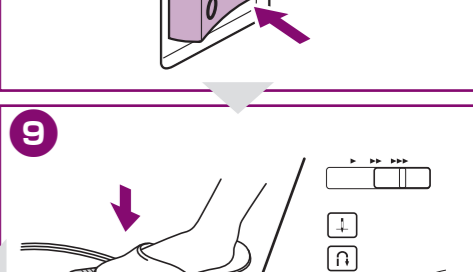
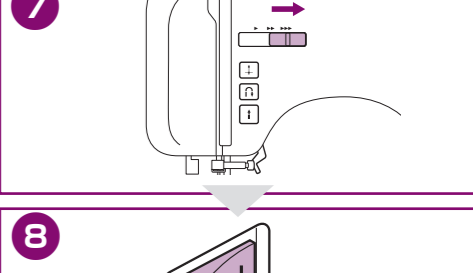
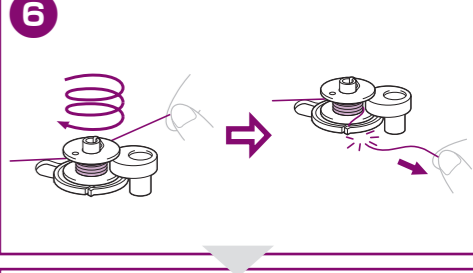
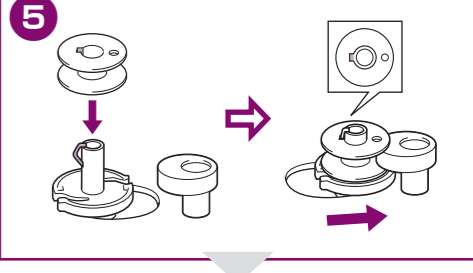
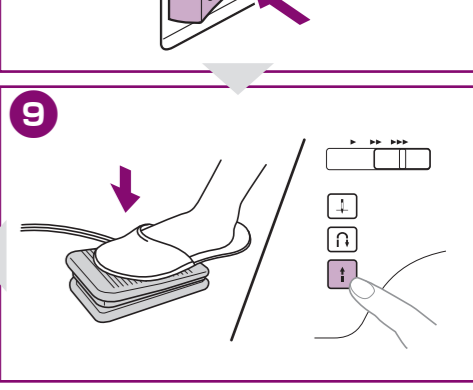
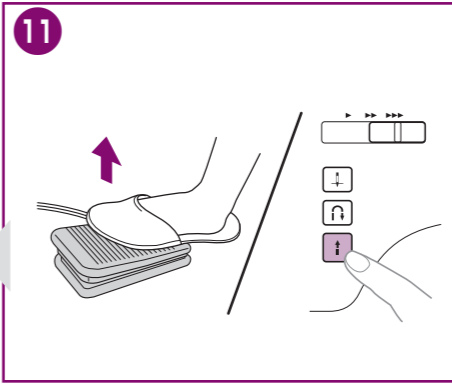
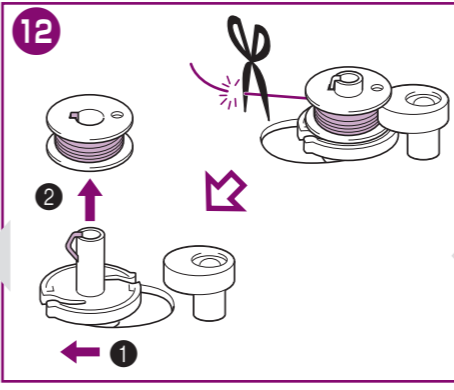
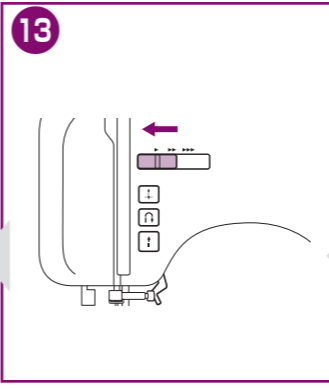
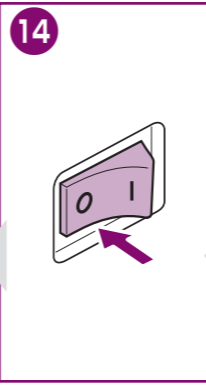
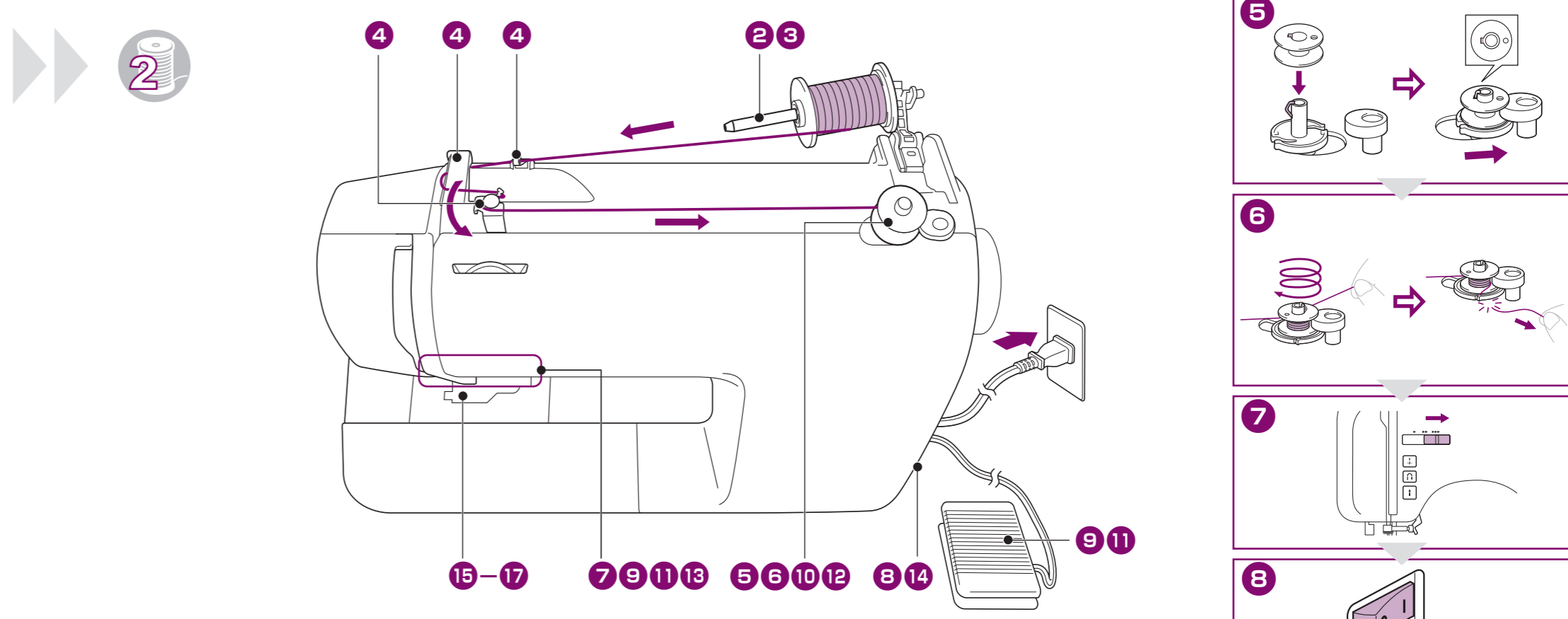
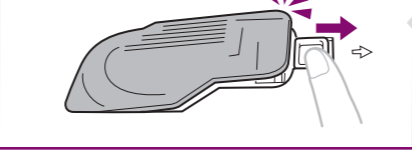
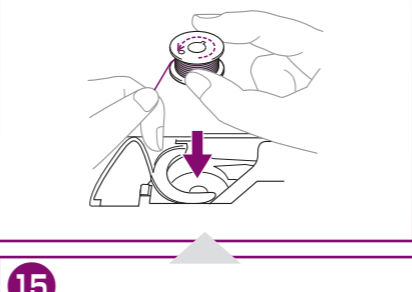
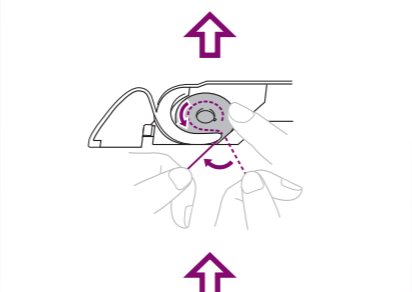
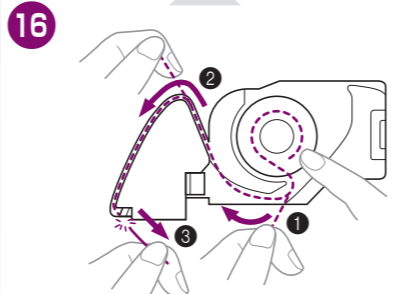
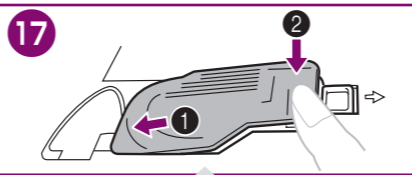
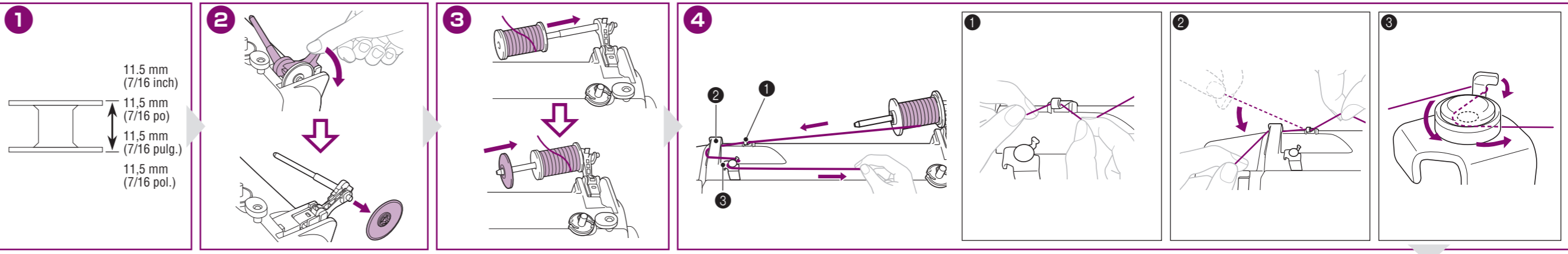

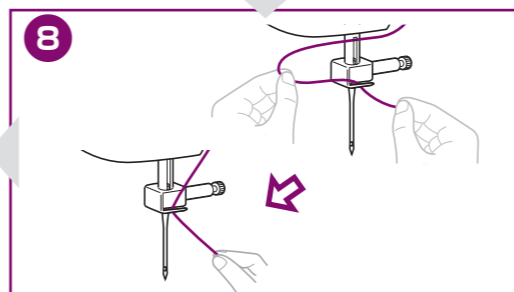
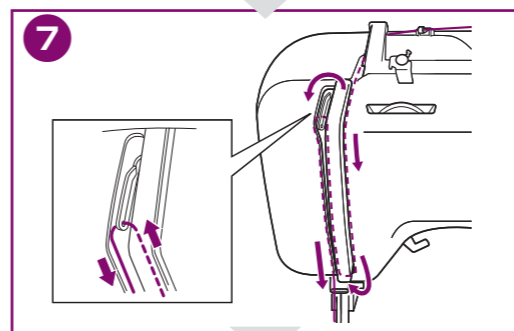
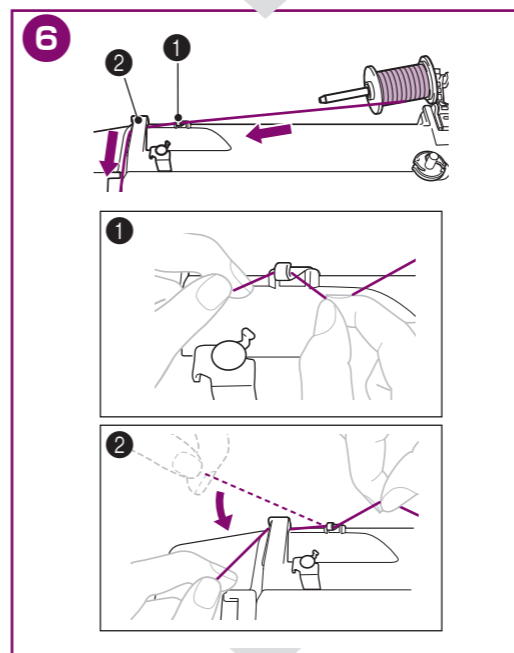
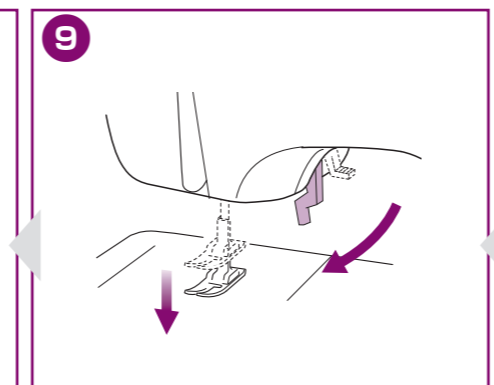
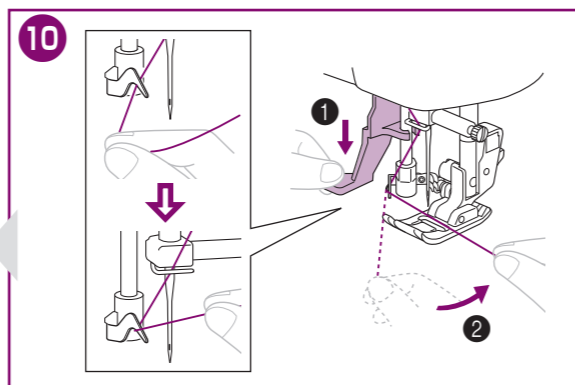
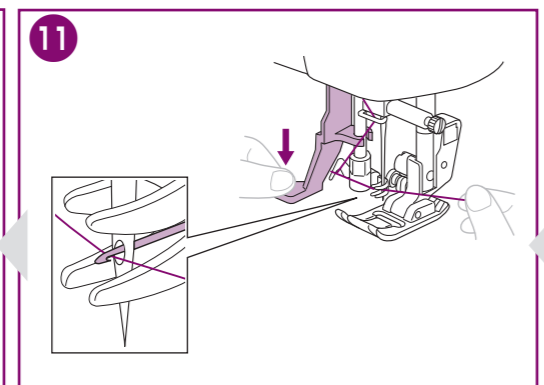
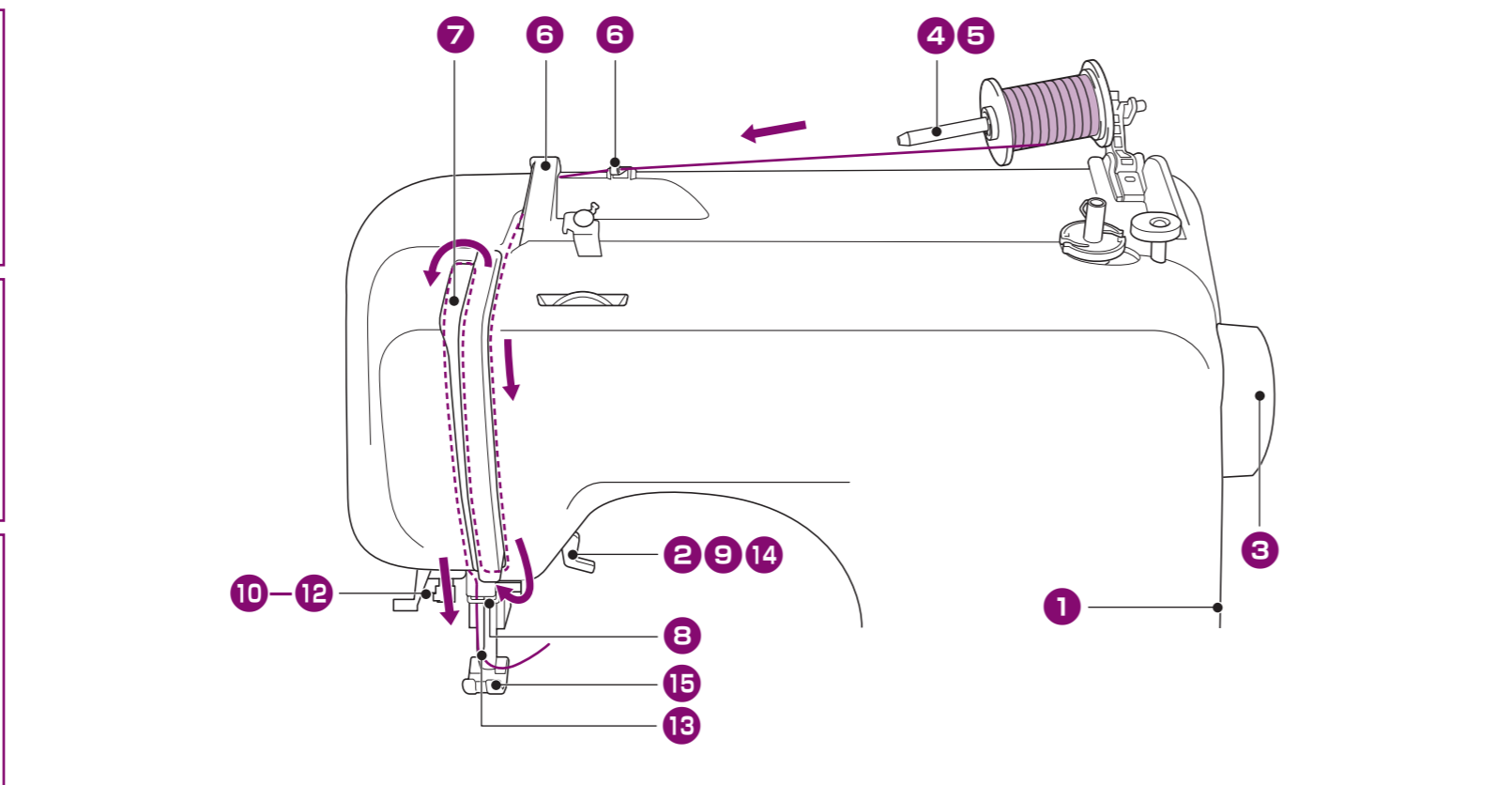
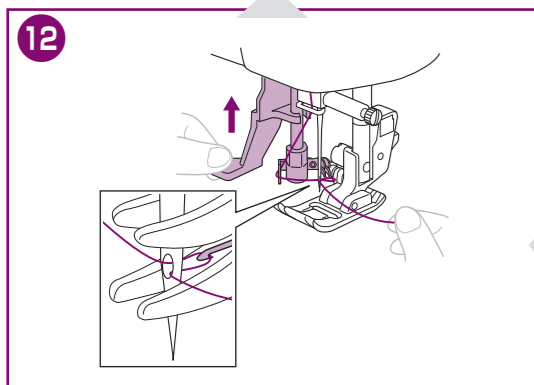
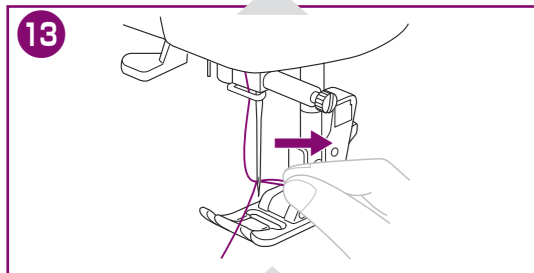
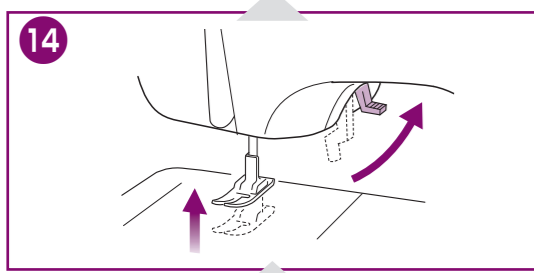
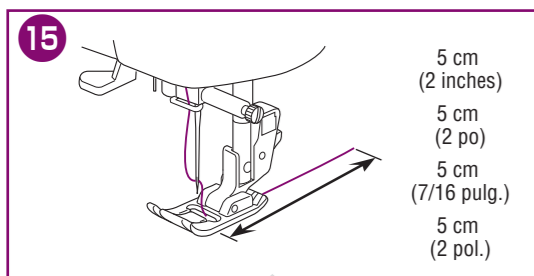
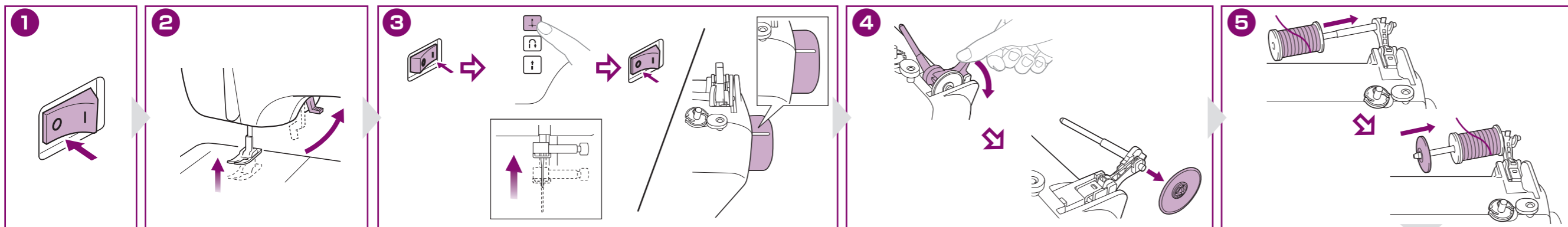

(EN) Quick Reference Guide
(FR) Guide de référence rapide
(ES) Guía de referencia rápida
(PT) Guia de referência rápida



Be sure to first read the "IMPORTANT SAFETY INSTRUCTIONS" in the Operation Manual. Refer to the Operation Manual for detailed instruction.

Lea primero las "INSTRUCCIONES DE SEGURIDAD IMPORTANTES" del Manual de instrucciones. Consulte el manual de instrucciones para obtener información detallada.

Lisez attentivement les « INSTRUCTIONS DE SÉCURITÉ IMPORTANTES » du Manuel d'instructions. Reportez-vous au Manuel d'instructions pour des directives détaillées.

Assegure-se de ler primeiro "INSTRUÇÕES DE SEGURANÇA IMPORTANTES" no Manual de Operações. Consulte o Manual de Operações para obter instruções detalhadas.

List of stitches / Liste des points / Lista de tipos de puntadas / Lista de pontos

00	01	02	03	04	05	06	07	08	09	00	01	02	03	04	05	06	07	08	09											
10	11	12	13	14	15	16	17	18	19	10	11	12	13	14	15	16	17	18	19											
20	21	22	23	24	25	26	27	28	29	20	21	22	23	24	25	26	27	28	29											
30	31	32	33	34	35	36	37	38	39	30	31	32	33	34	35	36	37	38	39											
40	41	42	43	44	45	46	47	48	49	40	41	42	43	44	45	46	47	48	49											
50	51	52	53	54	55	56	57	58	59	50	51	52	53	54	55	56	57	58	59											
60	61	62	63	64	65	66	67	68	69	60	61	62	63	64	65	66	67	68	69											
70	71	72	73	74	75	76	77	78	79	70	71	72	73	74	75	76	77	78	79											
80	81	82	83	84	85	86	87	88	89	80	81	82	83	84	85	86	87	88	89											
90	91	92	93	94	95	96	97	98	99	90	91	92	93	94	95	96	97	98	99											
										A																				
										01	02	03	04	05	06	07	08	09	10	11										
										A	B	C	D	E	F	G	H	I	J	K										
										12	13	14	15	16	17	18	19	20	21	22										
										L	M	N	O	P	Q	R	S	T	U	V										
										23	24	25	26	27	28	29	30	31	32	33										
										W	X	Y	Z	&	?	!	_	0	1	2										
										34	35	36	37	38	39	40	41	42	43	44										
										3	4	5	6	7	8	9	'	,	.	(
										45	46	47	48	49	50	51	52	53	54	55										
)	-	Ä	Å	Æ	Ñ	Ö	Ø	Ç	Ü	ß										

Useful Features / Fonctions utiles / Funciones útiles / Recursos úteis

- Quick-set bobbin
- Needle threader
- Fast bobbin winding system
- Canette à réglage rapide
- Enfileur d'aiguille
- Système de bobinage rapide de la canette
- Bobina rápida
- Enhebrador de aguja
- Sistema de devanado rápido de bobina
- Bobina de colocação rápida
- Enfiador de linha
- Sistema de enchimento da bobina rápido

Refer to the Operation Manual for detailed instruction.

Reportez-vous au Manuel d'instructions pour des directives détaillées.

Consulte el Manual de instrucciones para obtener información detallada.

Consulte o Manual de Operações para obter instruções detalhadas.