

brother®

**Quick reference guide**

**快速操作指南**

**快速導覽手冊**

**빠른 참조 안내서**

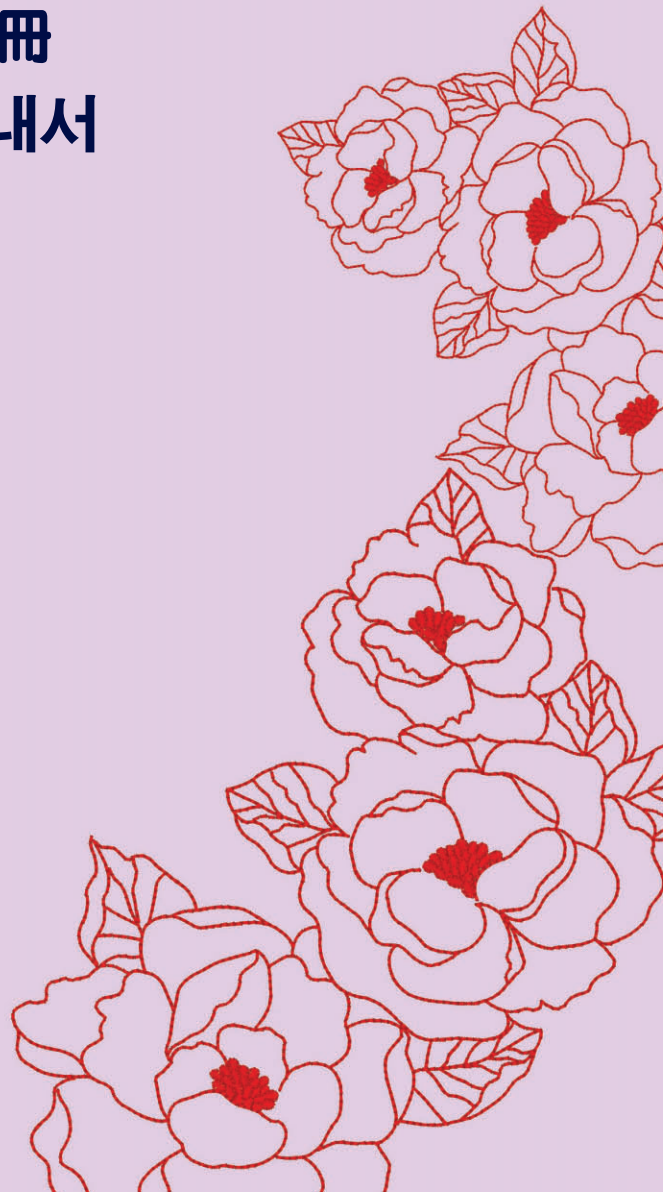
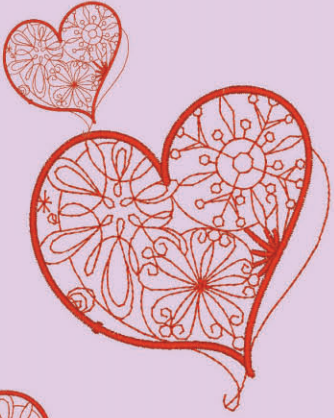
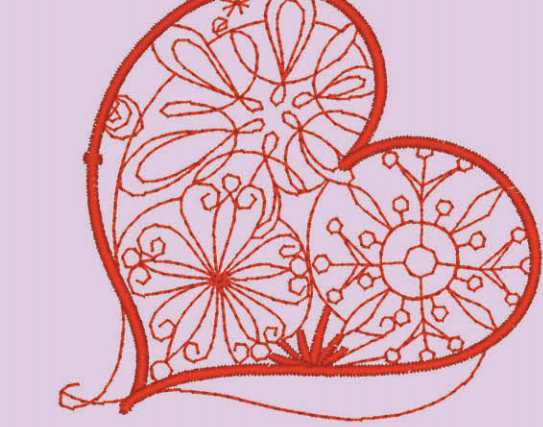

Refer to the operation manual for detailed instruction.

Also, there are differences in the keys and screens depending on the display language. In this guide, English screens are used for basic explanations.

有关详细说明，请参见使用说明书。

另外，按键和画面会因显示语言略有不同。在本指南中，使用英语画面进行基本说明。

關於詳細指示，請參閱使用說明書。

另外，不同顯示語言的按鍵及畫面會有所差異。在本說明書中，基本說明均以英文畫面為準。

자세한 내용은 작동 설명서를 참조하세요.

언어에 따라 키와 화면이 다릅니다. 이 안내서에서는 영어 화면을 기준으로 설명합니다.

### <English display>

<英语画面>

<英語顯示>

<영어 표시>

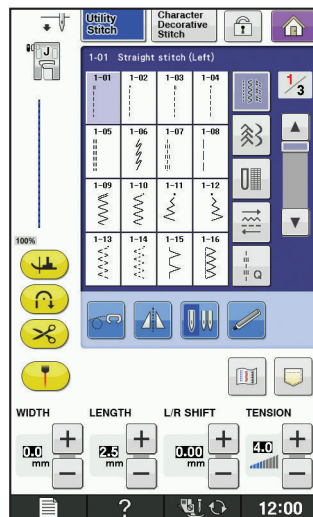

### <Example: Simplified Chinese>

<示例：简体中文>

<範例：簡體中文>

<예: 중국어 간체>

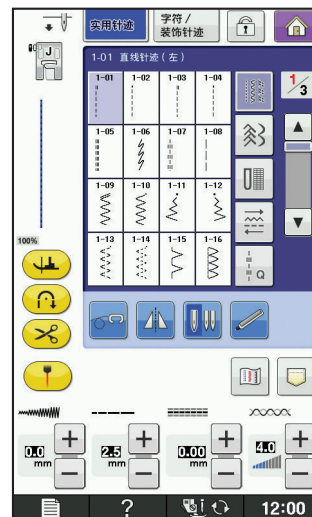

Copyright, Zündt Design 2012, All rights reserved.

All artwork and designs created by Zündt Design, Ltd are copyrighted. The embroidery data you obtain from zundtdesign.com and Zündt Design, Ltd is licensed for customer use only.

所有 Zündt Design, Ltd 的作品和设计受版权保护。从 zundtdesign.com 和 Zündt Design, Ltd 获取的绣花数据仅供客户许可使用。

Zündt Design, Ltd. 創作的的所有作品與設計均受版權保護。您從 zundtdesign.com 和 Zündt Design, Ltd. 取得的刺繡資料僅供顧客使用。

Zündt Design, Ltd 가 만든 모든 아트워크와 디자인은 저작권법으로 보호됩니다. zundtdesign.com 및 Zündt Design, Ltd 에서 입수한 자수 데이터는 고객만 사용할 수 있습니다.

## Contents

Winding the Bobbin .....	2
Setting the Bobbin .....	4
Upper Threading.....	5
Preparing to Embroider .....	6
Selecting Stitch Patterns .....	8
Summary of Stitch Patterns.....	13
Embroidery Pattern Color Change Table.....	30
Examples of Combinations.....	51
Color Thread Conversion Chart.....	56

## 目录

梭芯绕线 .....	2
设置梭芯 .....	4
面线穿线 .....	5
准备绣花 .....	6
选择针迹花样 .....	8
针迹花样摘要 .....	13
绣花花样颜色变更表 .....	30
花样组合示例 .....	51
绣花线颜色转换表 .....	56

## 目錄

梭子繞線 .....	2
安裝梭子 .....	4
穿上線 .....	5
準備刺繡 .....	6
選擇針跡花樣 .....	8
刺繡花樣概要 .....	13
刺繡花樣顏色轉換表 .....	30
組合範例 .....	51
繡線顏色轉換表 .....	56

## 목차

실토리 감기 .....	2
실토리 설정 .....	4
윗실 끼우기 .....	5
자수 준비 .....	6
재봉 패턴 선택 .....	8
재봉 패턴 요약 .....	13
자수 패턴 색 변경 표 .....	30
조합 예 .....	51
색실 변환 차트 .....	56

# Winding the Bobbin

## 梭芯绕线

## 梭子繞線

## 실토리 감기

Follow the numbered steps below in order. Refer to the operation manual for detailed instruction.  
 遵循下面按顺序编号的步骤。有关详细说明，请参见使用说明书。  
 依序按下列編號步驟進行。關於詳細指示，請參閱使用說明書。  
 아래 번호 순서를 따르세요. 자세한 내용은 작동 설명서를 참조하세요.

Use only the enclosed bobbin or bobbins of the same type.  
 仅使用随机附带的梭芯或者同类型的梭芯。  
 只能使用隨附的梭子或相同類型的梭子。  
 동봉된 실토리 또는 같은 종류의 실토리만 사용하세요.

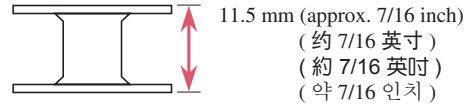

### ◆ Using the Supplemental Spool Pin

You can wind the bobbin during sewing.

### ◆ 使用辅助的线筒轴

您可以在绣制的过程中进行梭芯绕线。

### ◆ 使用輔助線輪柱

可以在縫紉過程中繞線。

### ◆ 보조 실패꽃이 사용

제봉 중에 실토리를 감을 수 있습니다.

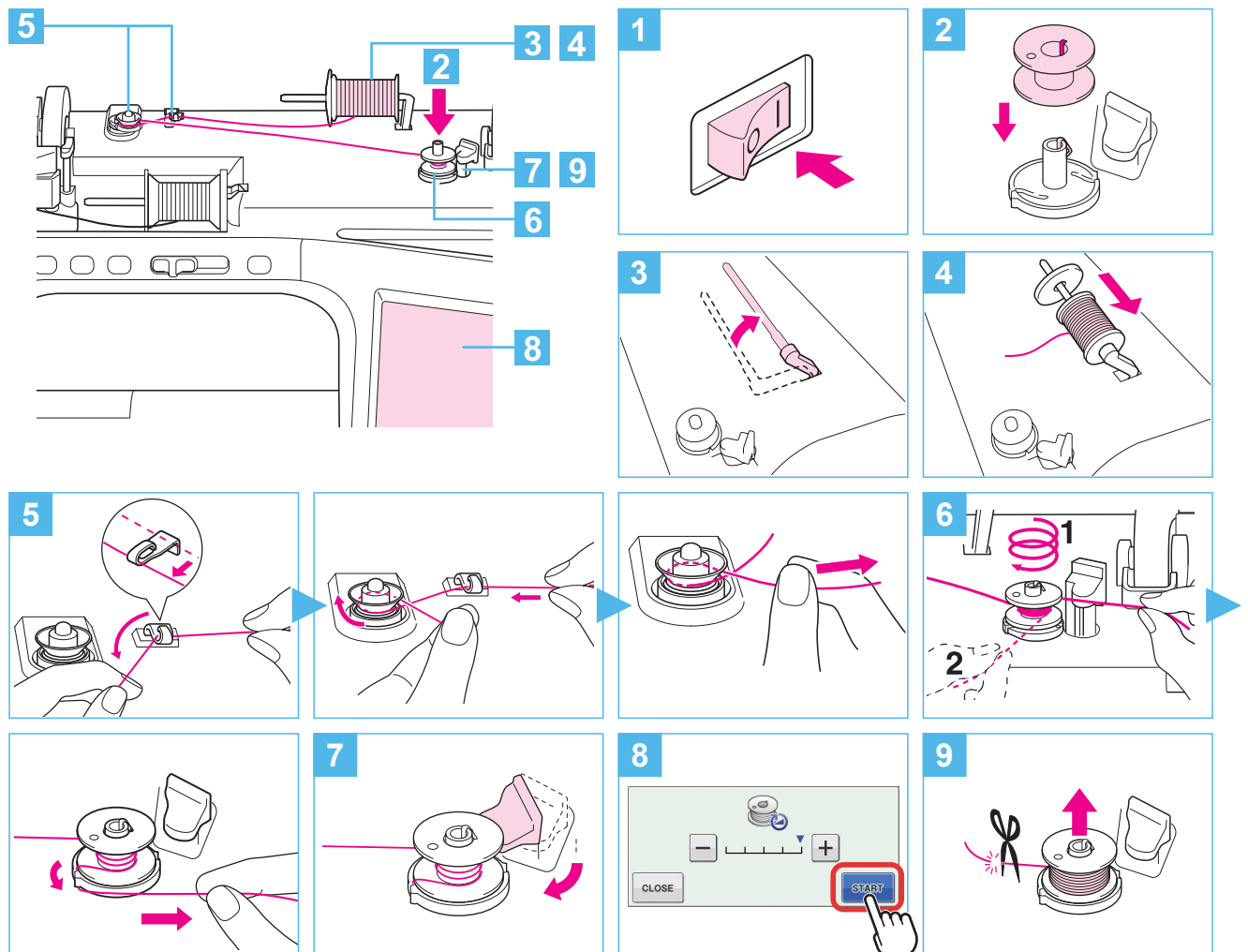

◆ **Using the Spool Pin**

You can use the main spool pin to wind the bobbin before sewing.

◆ **使用线筒轴**

可以在绣制之前使用主线筒轴进行梭芯绕线。

◆ **使用線輪柱**

縫紉前，可以使用主線輪柱來繞線。

◆ **실패꽃이 사용**

재봉 전에 메인 실패꽃이를 사용하여 실토리를 감을 수 있습니다.

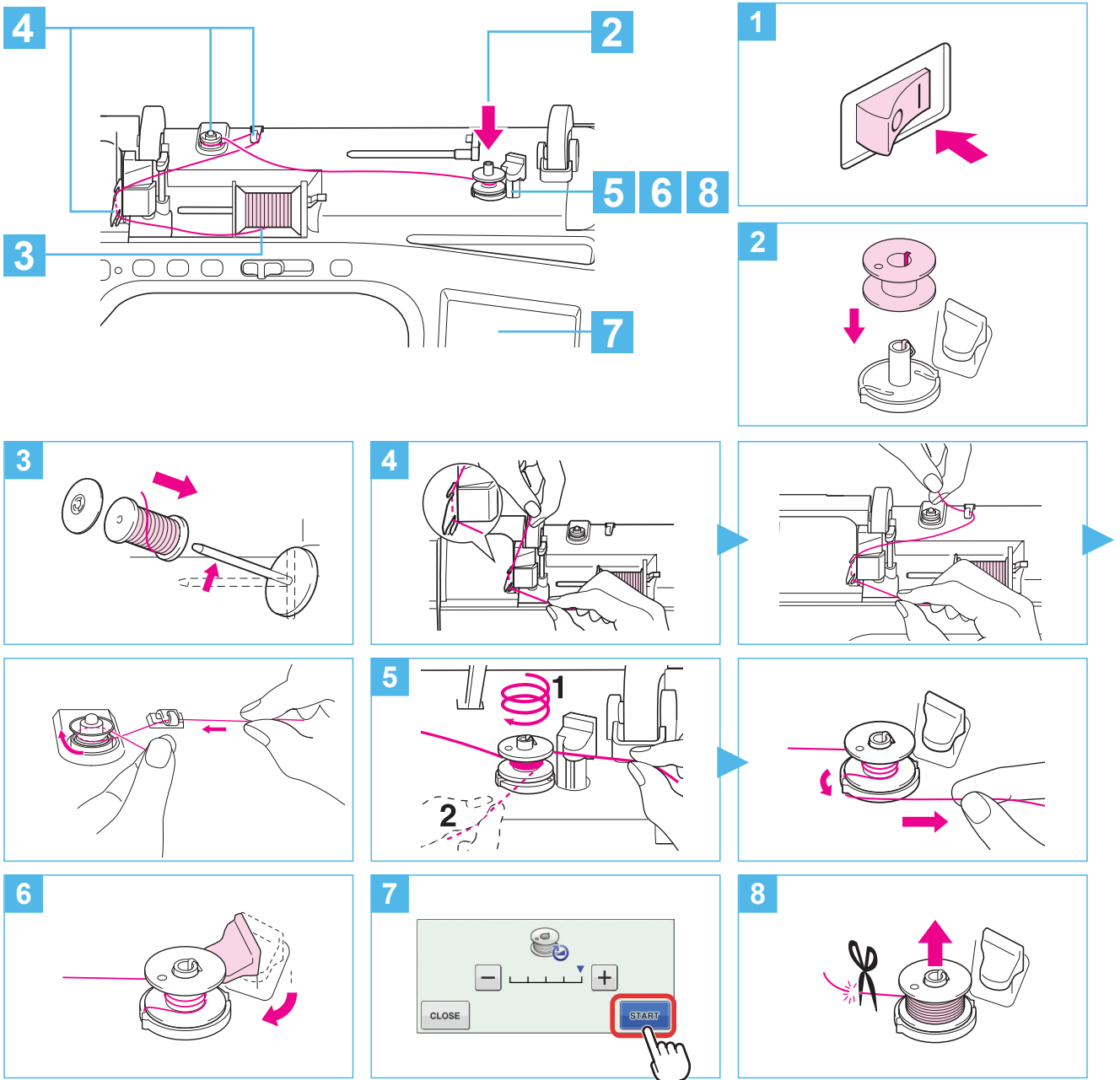

# Setting the Bobbin

## 设置梭芯

## 安裝梭子

## 실토리 설정

Refer to the operation manual for detailed instruction.

有关详细说明，请参见使用说明书。

關於詳細指示，請參閱使用說明書。

자세한 내용은 작동 설명서를 참조하세요.

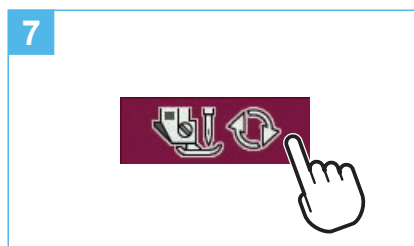
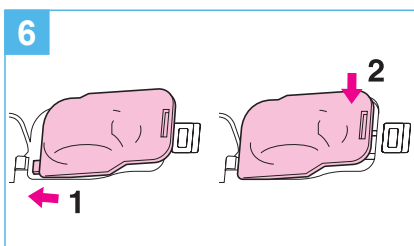
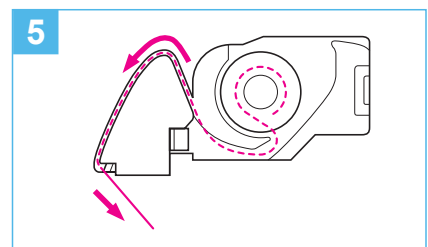
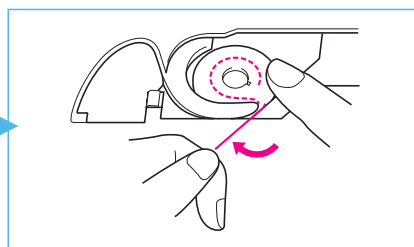
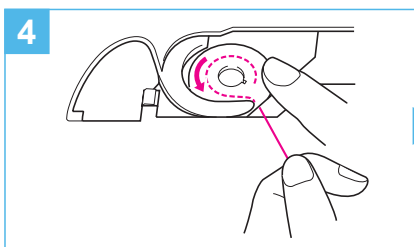
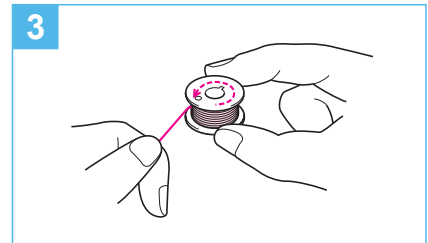
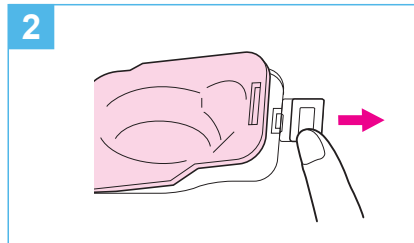

# Upper Threading

面线穿线  
穿上線  
윗실 끼우기

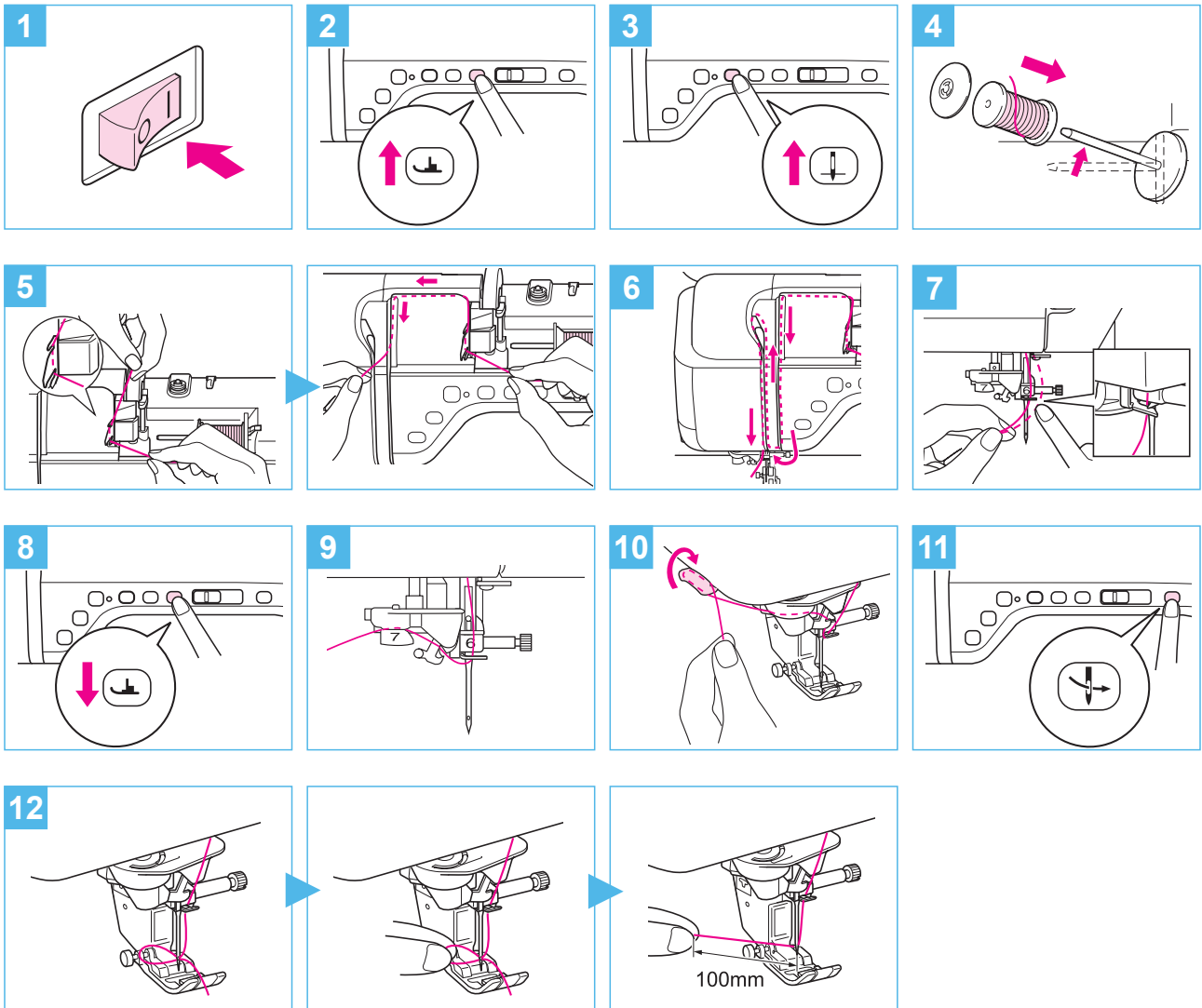
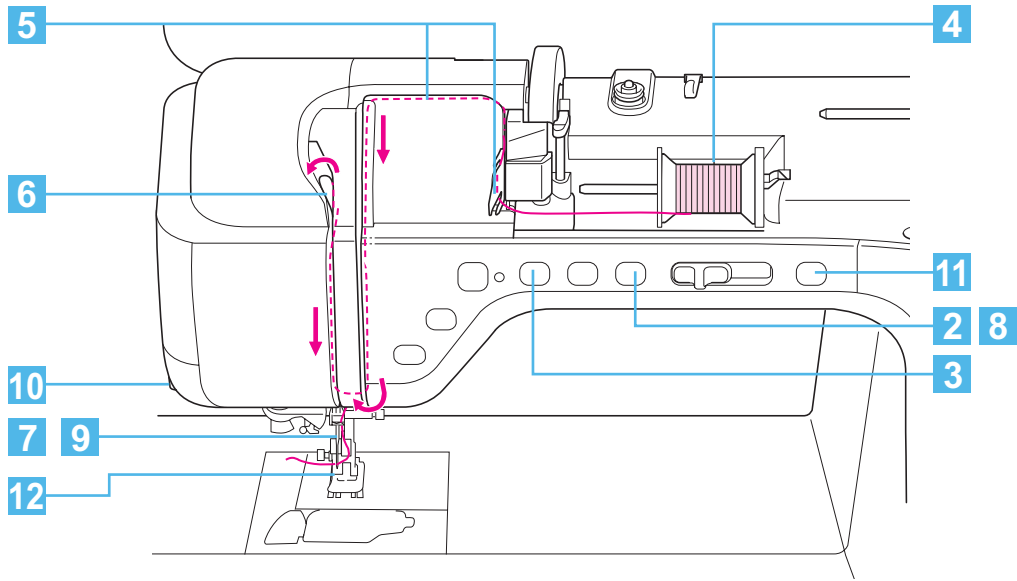

# Preparing to Embroider

准备绣花  
準備刺繡  
자수 준비

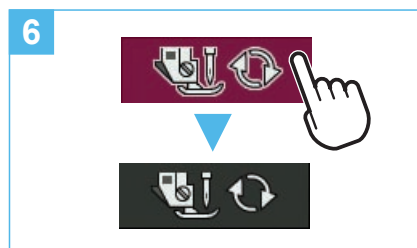
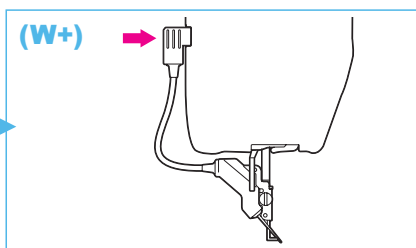
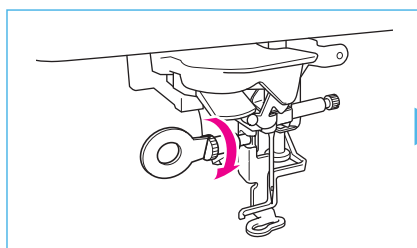
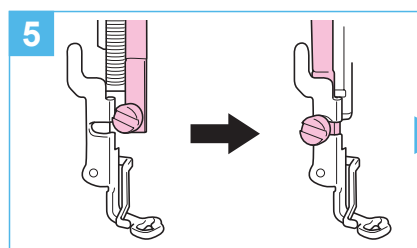
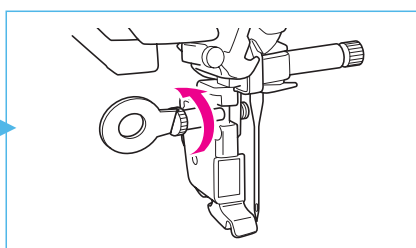
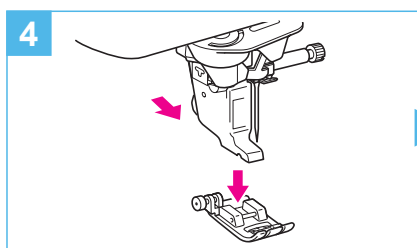
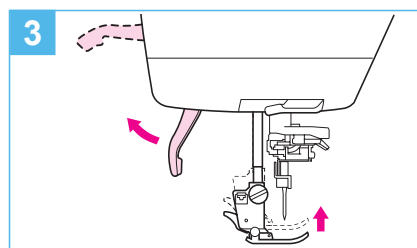
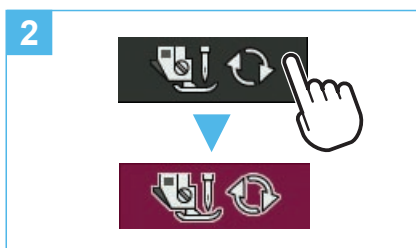
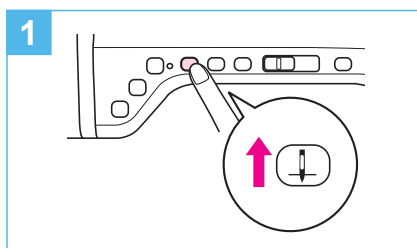
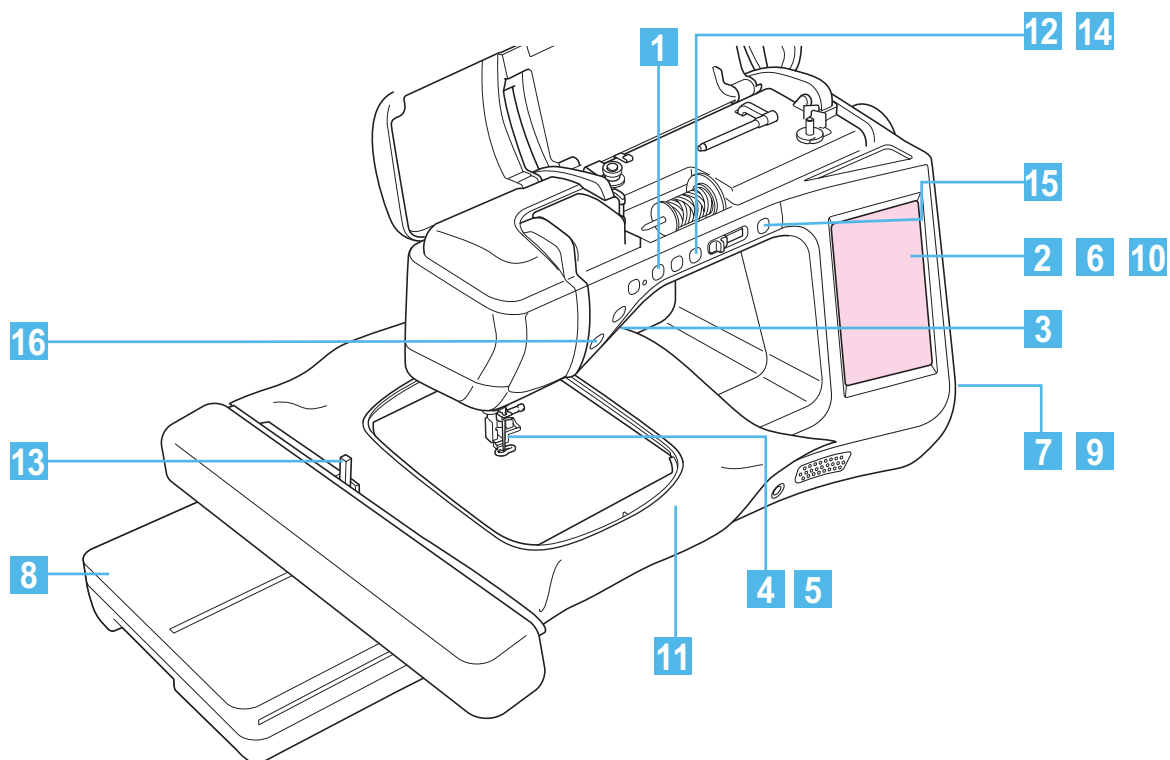



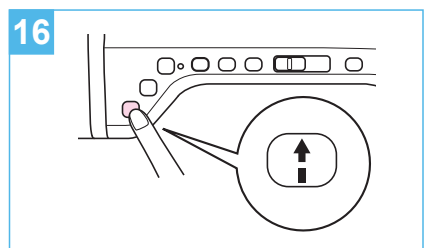
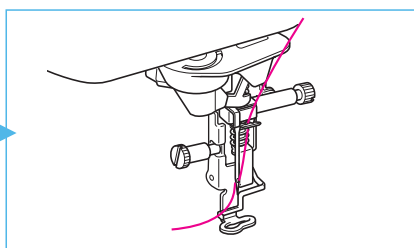
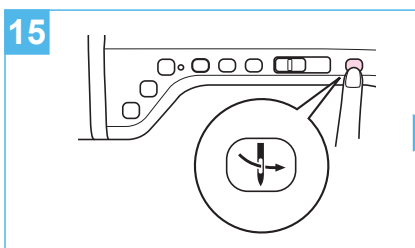
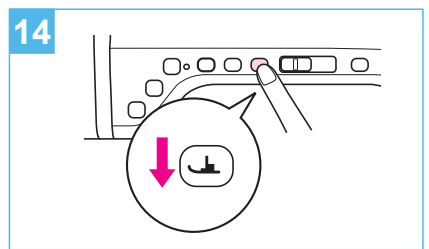
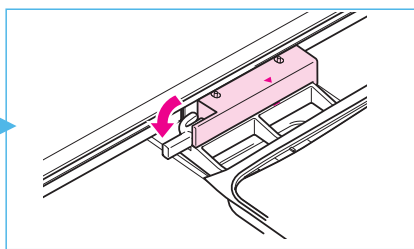
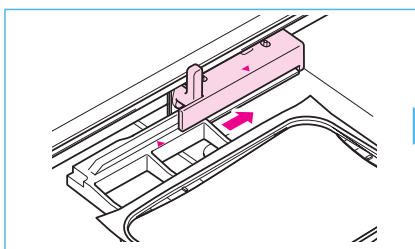
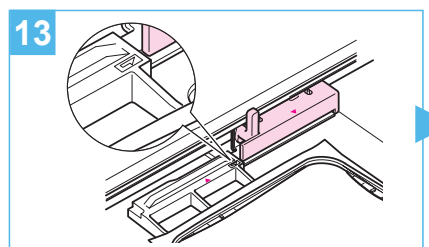
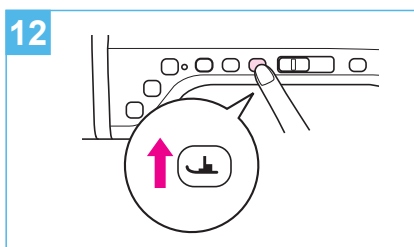
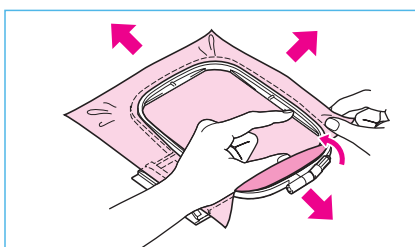
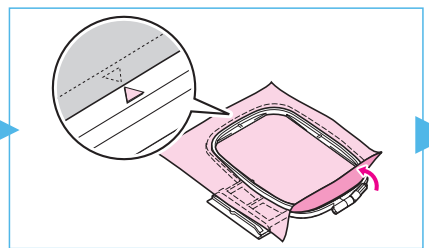
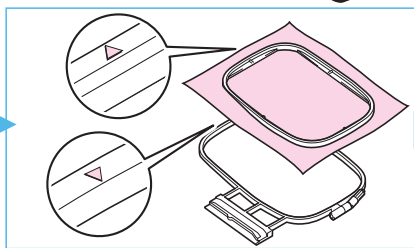
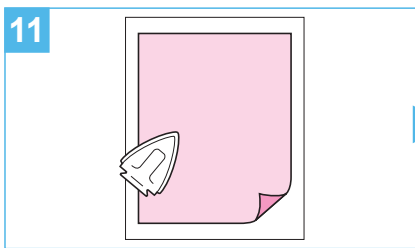
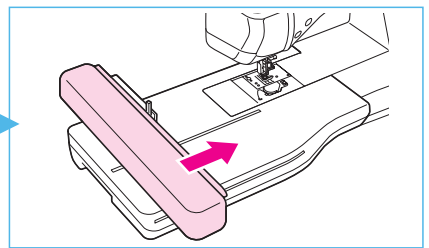
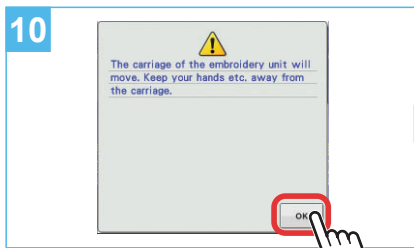
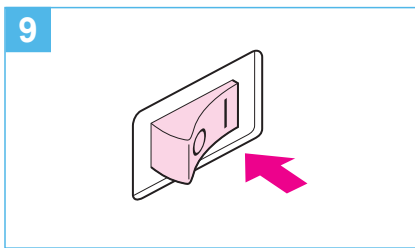
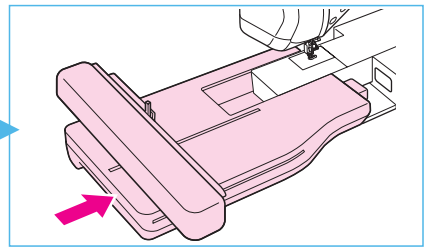
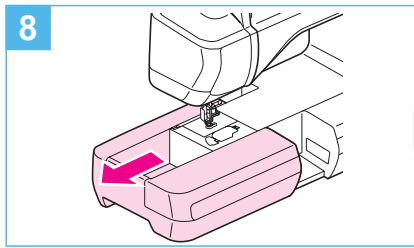
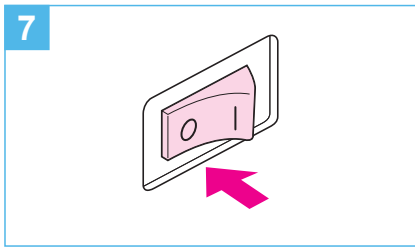



## ◆ Utility Stitches

When the machine is turned on, the opening movie is played. Touch the screen to display the home screen. Press  to display the Utility Stitch. Either "1-01 Straight stitch (Left)" or "1-03 Straight stitch (Middle)" is selected, depending on the setting selected in the settings screen.

## ◆ 实用针迹

当机器开启时,会显示开机动画。触摸屏幕以显示主画面。按下  以显示实用针迹。根据设置画面中所选择的设置,可以选择“1-01 直线针迹(左)”或“1-03 直线针迹(中)”。

## ◆ 實用針趾

本機開機後,會播放歡迎動畫。觸摸螢幕顯示主頁畫面。按  顯示實用針趾。因設定畫面中選擇的設定而異,選取「1-01 直線針趾(左針位)」或「1-03 直線針趾(中針位)」。

## ◆ 실용 재봉

기기가 켜질 때에 오픈링 동영상 이 재생됩니다. 화면을 터치하여 초기 화면을 표시하세요.  를 눌러서 실용 재봉을 표시하세요. 설정 화면에서 선택한 설정에 따라 “1-01 직선 재봉 (왼쪽)” 또는 “1-03 직선 재봉 (가운데)” 가 선택됩니다.

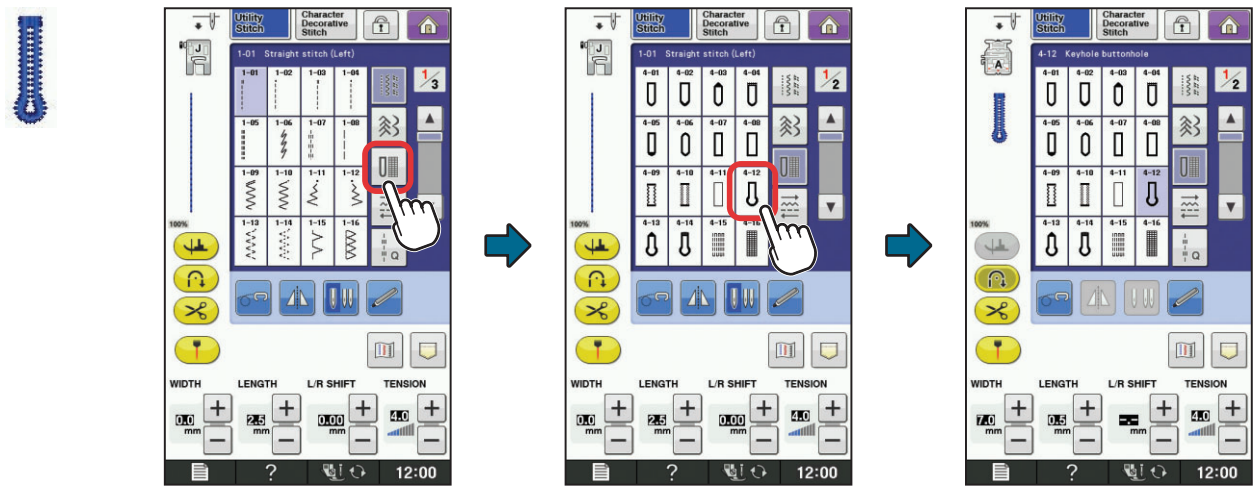

## ◆ Character/Decorative Stitches

### ◆ 字母 / 装饰针迹

### ◆ 文字 / 裝飾性針趾

### ◆ 문자 / 장식 재봉

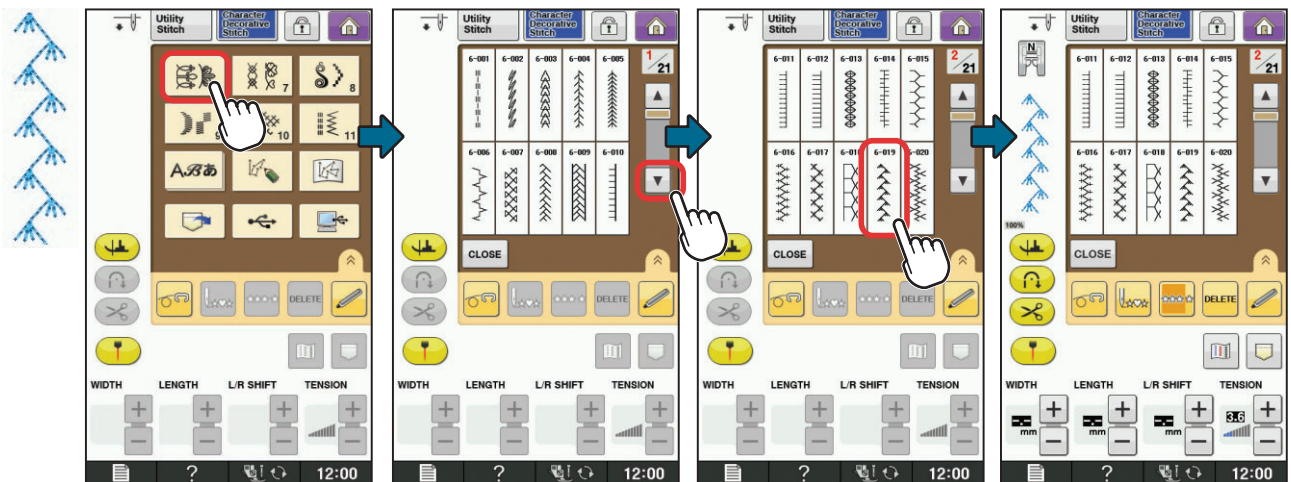

◆ Embroidery Patterns

◆ 绣花花样

◆ 刺繡花樣

◆ 자수 패턴

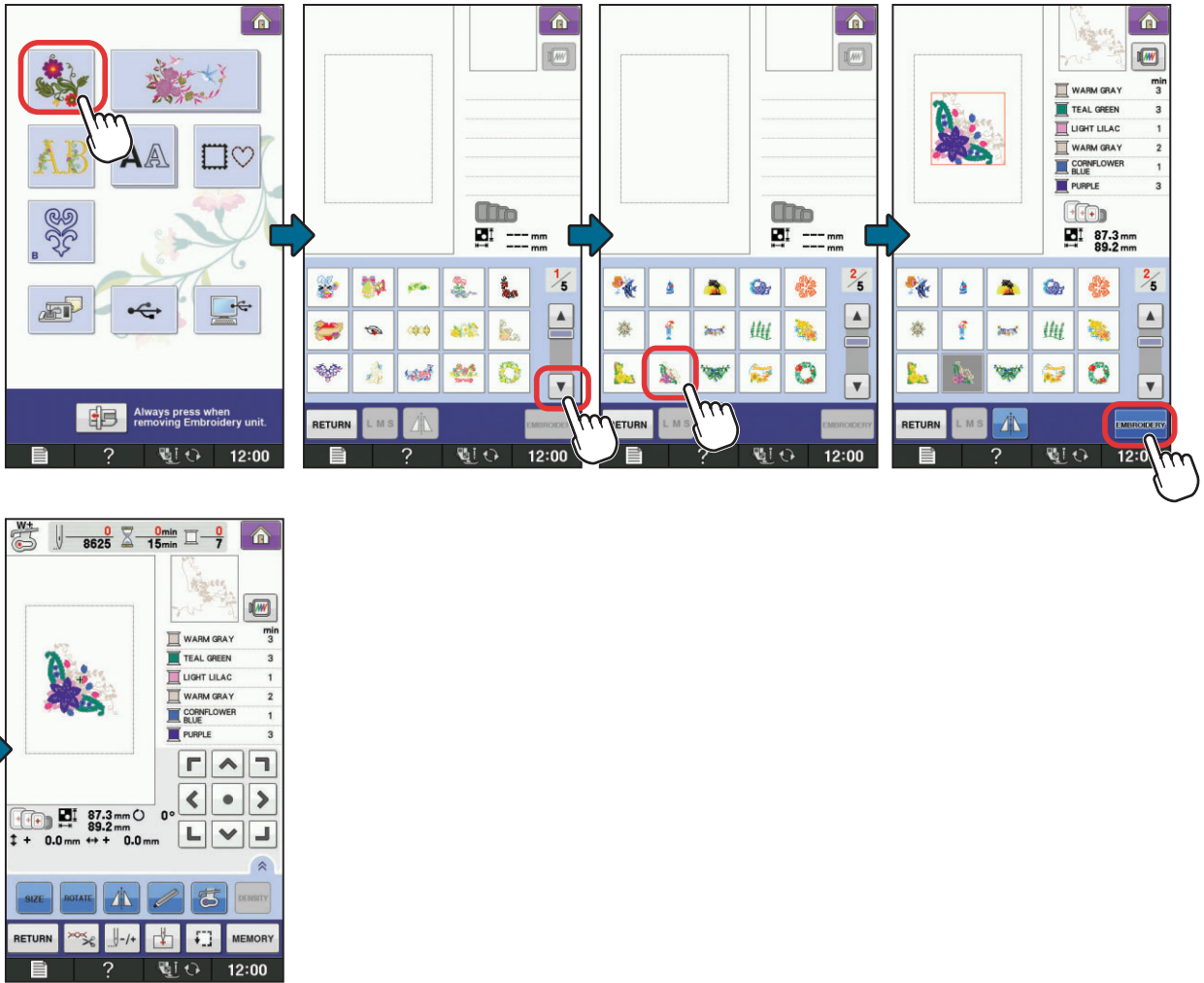



◆ Embroidery Edit Patterns

◆ 绣花编辑花样

◆ 刺繡花樣編輯

◆ 자수 편집 패턴



# Selecting Stitch Patterns

选择针迹花样  
選擇針跡花樣  
재봉 패턴 선택

## ◆ Settings

### ◆ 设置

### ◆ 設定

### ◆ 설정



The settings menu is organized into several sections:

- Width Control:** ON/OFF, Fine Adjust Vert. (00), Fine Adjust Horiz. (00), Presser Foot Height (1.5 mm), Presser Foot Pressure (8), Dual Feed Feed Adjustment (00).
- Initial Position:** Initial Position, Initial Stitch Page, Multi Function Foot Controller (Needle Position UP/DOWN, Thread Cutting).
- Pivoting Height:** 8.2 mm, Free Motion Foot Height (1.0 mm), Automatic Fabric Sensor System (ON/OFF), Guideline Marker Adjustment (START).
- Needle Position - UP/DOWN:** ON/OFF, Needle Position - Stitch Placement (ON/OFF), Mouse Pointer, Upper and Bobbin Thread Sensor (ON/OFF), Machine Speaker Volume (8).
- Eco Mode:** OFF, Shutoff Support Mode (OFF), Opening Screen, Language (English).
- Light:** 5, Screen Display Brightness (5), Sensor Function Calibration (+).
- Embroidery Frame Display:** 18 cm x 13 cm, #123 ABC, #123 Embroidery, Service Count (00000000), Total Count (00000000), No. (\*\*\*\*\*), Version 1 (1.00), Version 2 (1.00), Max Embroidery Speed (1050 spm), Embroidery Tension (00), Embroidery Foot Height (1.5 mm).
- Initial Mode:** Embroidery Background Color (SELECT), Thumbnail Background Color (SELECT), Thumbnail Size.
- Embroidery Basting Distance:** 5.0 mm, Embroidery Foot with LED Pointer Adjustment (START).

# Summary of Stitch Patterns

## 针迹花样摘要

## 刺繡花樣概要

## 재봉 패턴 요약

### ◆ Utility Stitches

### ◆ 实用针迹

### ◆ 實用針跡

### ◆ 실용 재봉

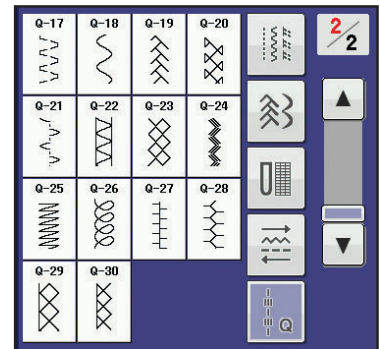
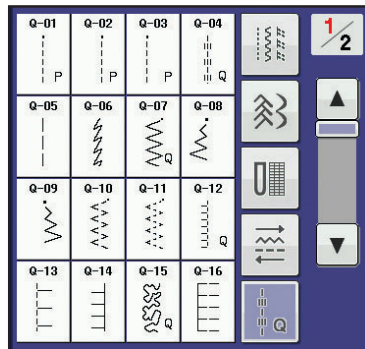
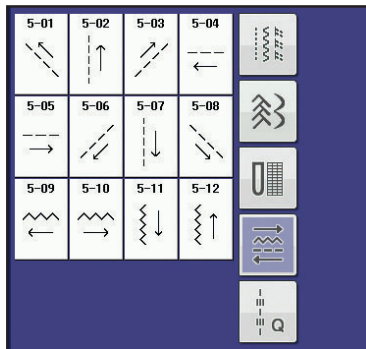
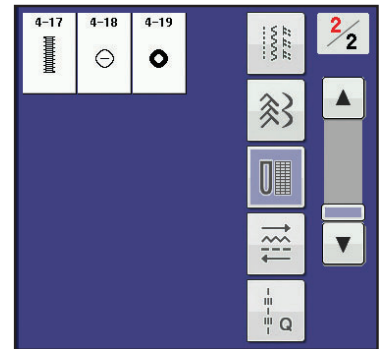
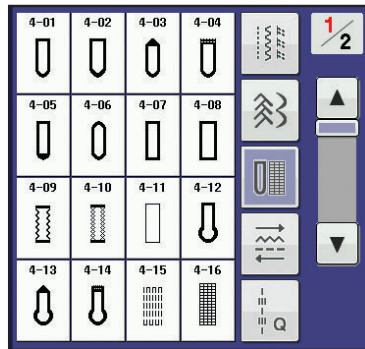
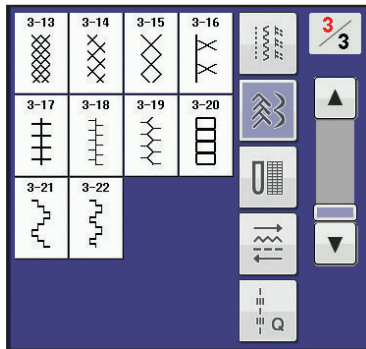
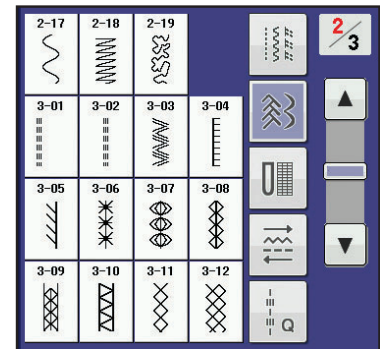
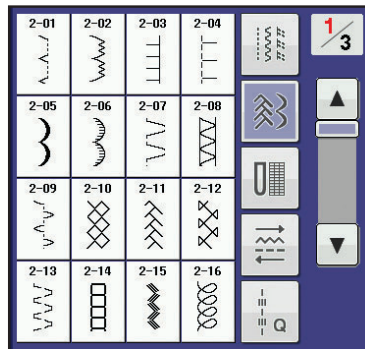
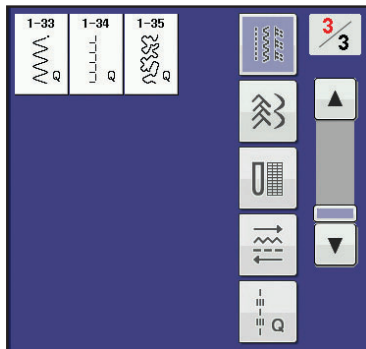
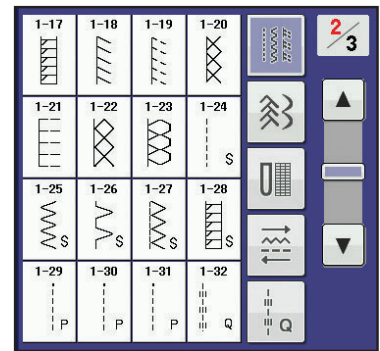
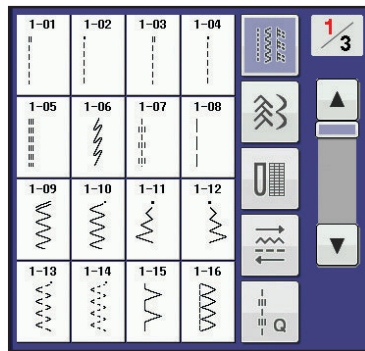
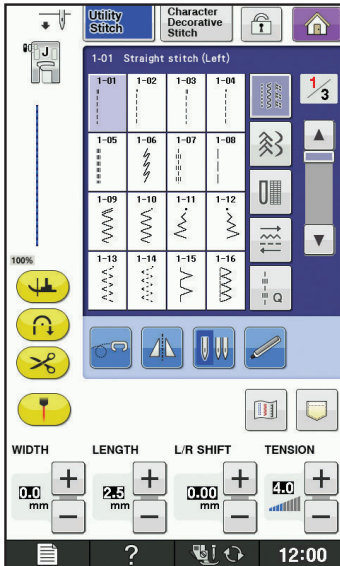

◆ Character/Decorative Stitches

◆ 字母 / 装饰针迹

◆ 文字 / 装饰性针迹

◆ 문자 / 장식 재봉

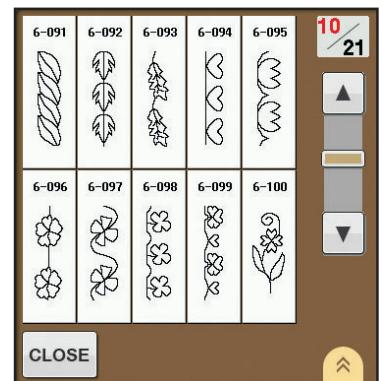
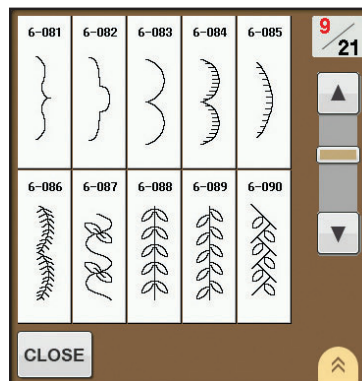
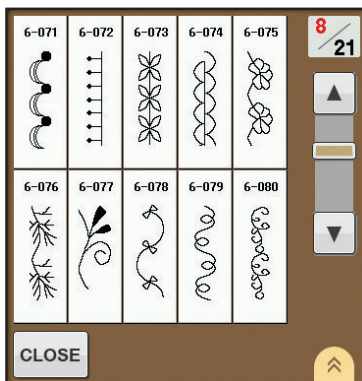
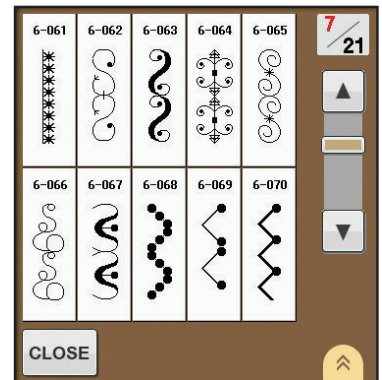
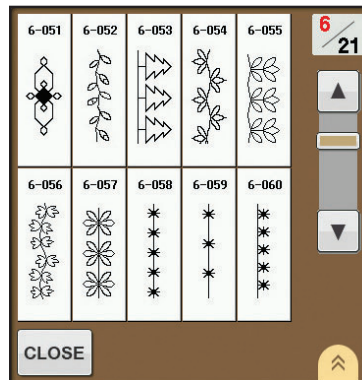
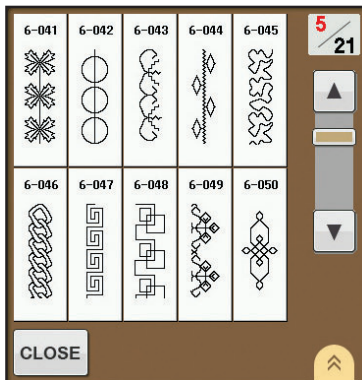
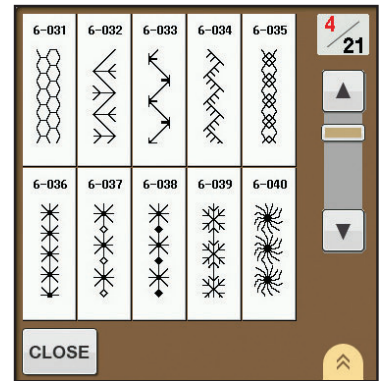
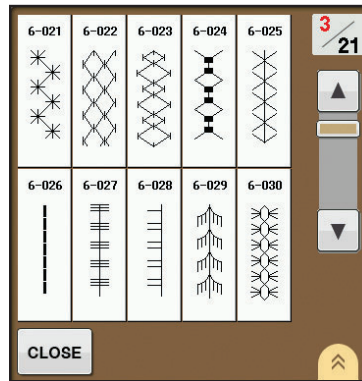
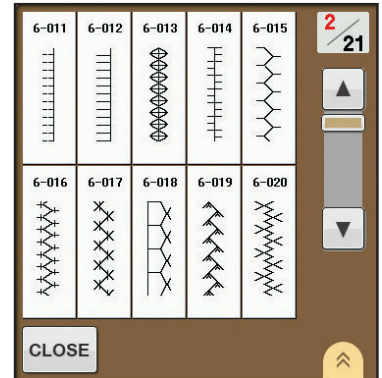
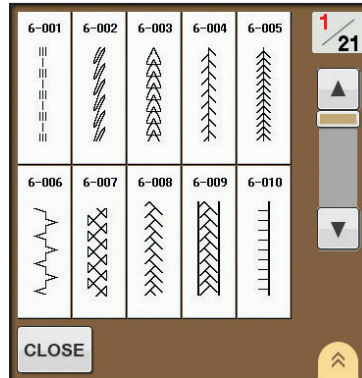
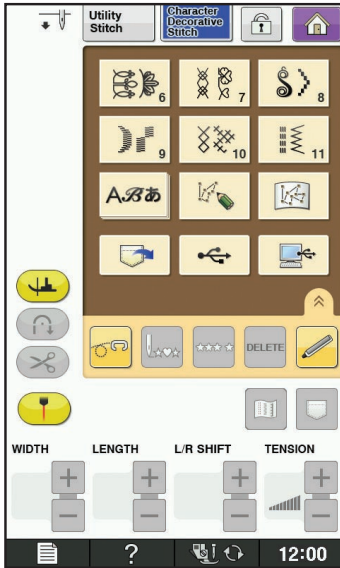



Summary of Stitch Patterns  
 针迹花样摘要  
 刺繡花樣概要  
 재봉 패턴 요약

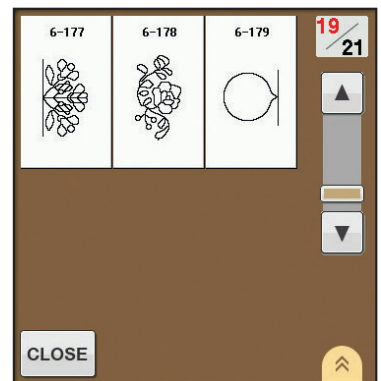
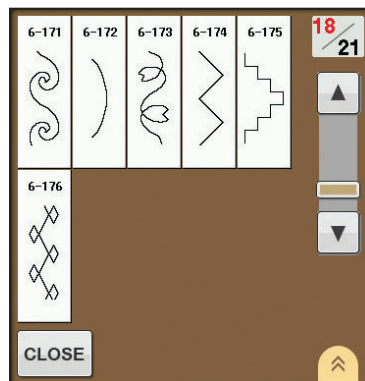
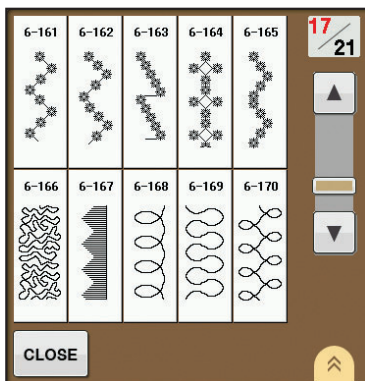
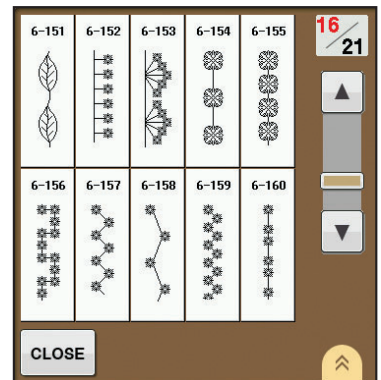
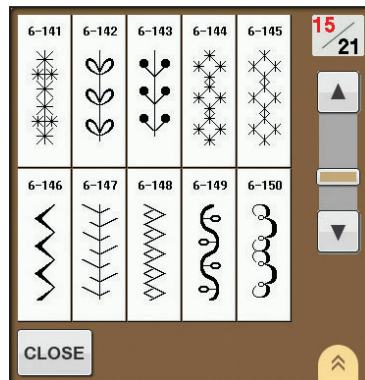
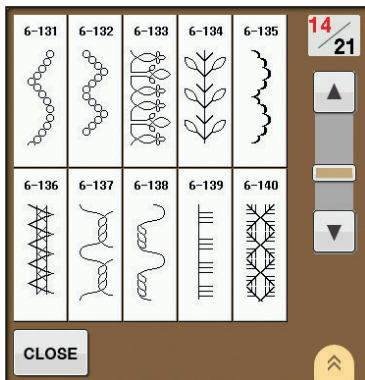
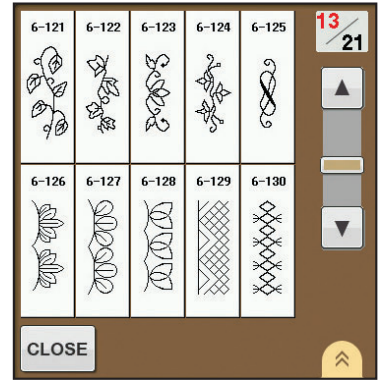
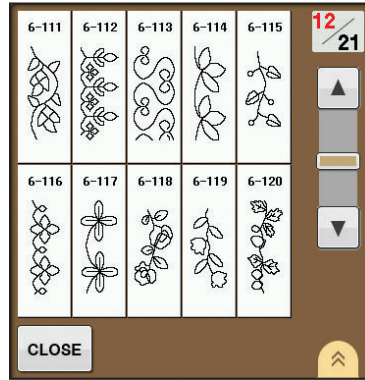

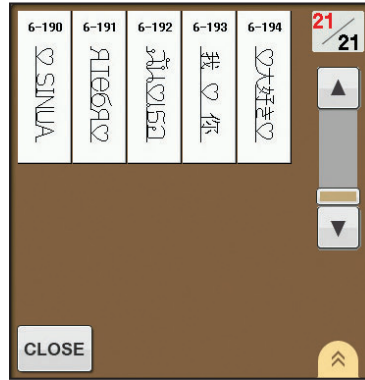
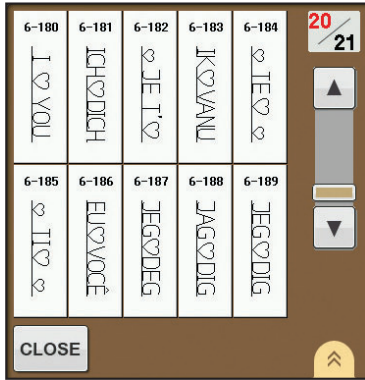

6-180: English  
 6-181: German  
 6-182: French  
 6-183: Dutch  
 6-184: Spanish  
 6-185: Italian  
 6-186: Portuguese  
 6-187: Norwegian  
 6-188: Swedish  
 6-189: Danish  
 6-190: Finnish  
 6-191: Russian  
 6-192: Thai  
 6-193: Simplified Chinese  
 6-194: Japanese

6-180: 英語  
 6-181: 德語  
 6-182: 法語  
 6-183: 荷蘭語  
 6-184: 西班牙語  
 6-185: 意大利語  
 6-186: 葡萄牙語  
 6-187: 挪威語  
 6-188: 瑞典語  
 6-189: 丹麥語  
 6-190: 芬蘭語  
 6-191: 俄語  
 6-192: 泰語  
 6-193: 簡體中文  
 6-194: 日語

6-180 : 英語  
 6-181 : 德語  
 6-182 : 法語  
 6-183 : 荷蘭語  
 6-184 : 西班牙語  
 6-185 : 義大利語  
 6-186 : 葡萄牙語  
 6-187 : 挪威語  
 6-188 : 瑞典語  
 6-189 : 丹麥語  
 6-190 : 芬蘭語  
 6-191 : 俄語  
 6-192 : 泰語  
 6-193 : 簡體中文  
 6-194 : 日語

6-180: 영어  
 6-181: 독일어  
 6-182: 프랑스어  
 6-183: 네덜란드어  
 6-184: 스페인어  
 6-185: 이탈리아어  
 6-186: 포르투갈어  
 6-187: 노르웨이어  
 6-188: 스웨덴어  
 6-189: 덴마크어  
 6-190: 핀란드어  
 6-191: 러시아어  
 6-192: 태국어  
 6-193: 중국어 간체  
 6-194: 일본어

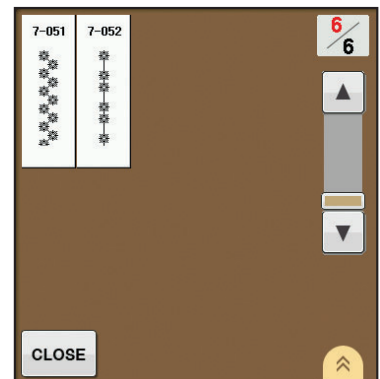
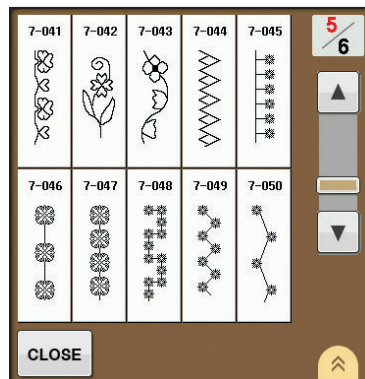
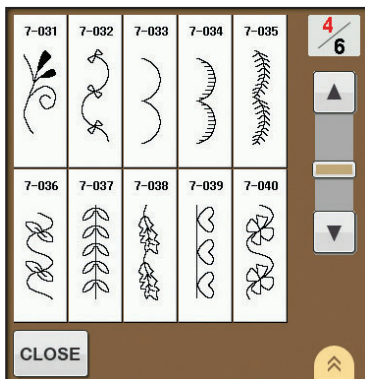
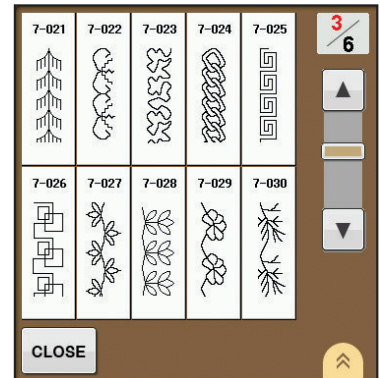
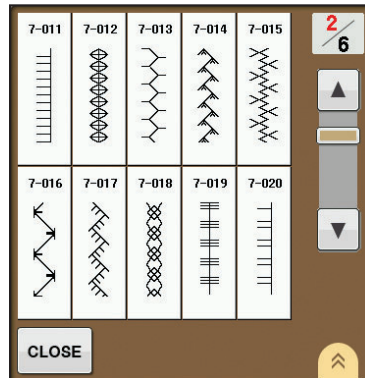
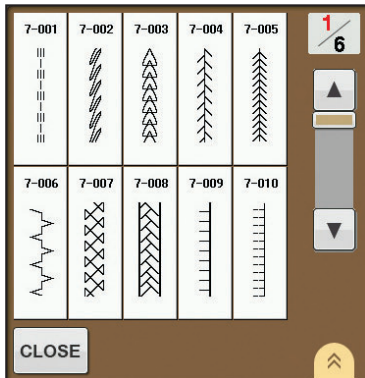
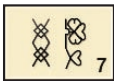

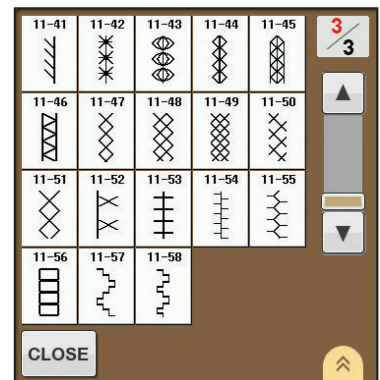
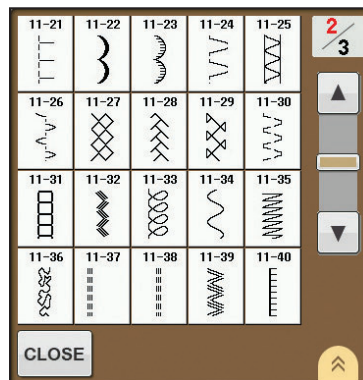
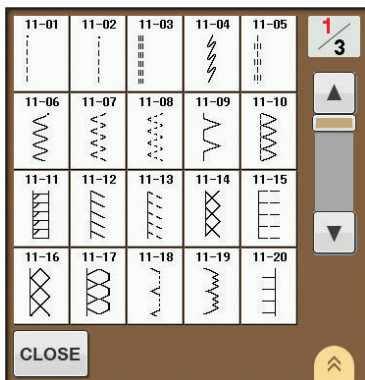
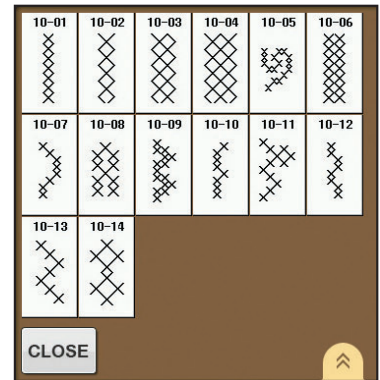
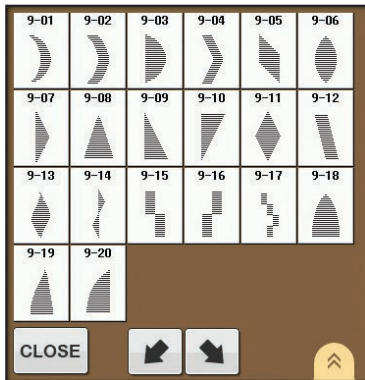
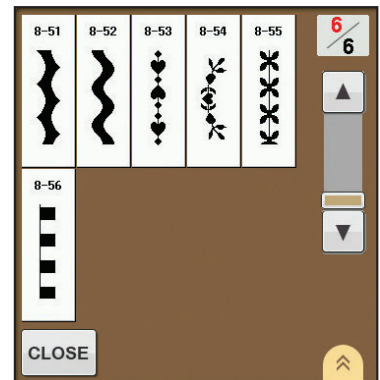
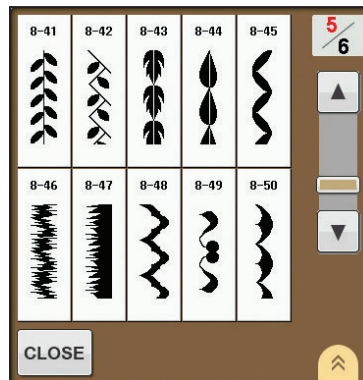
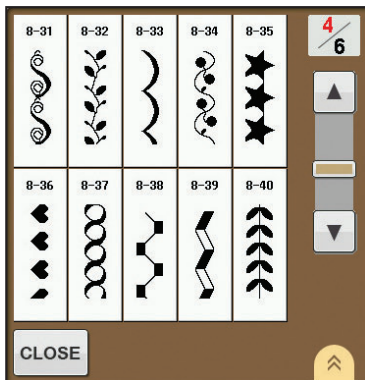
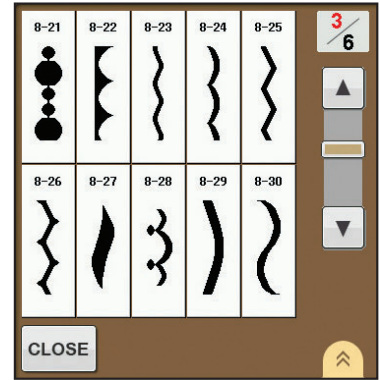
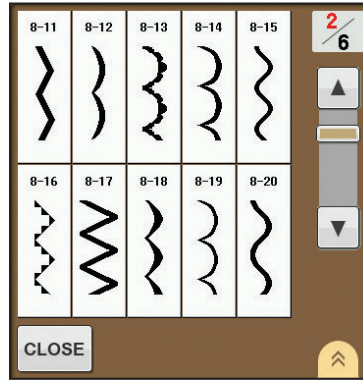
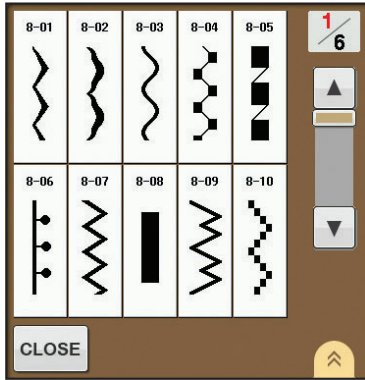

ABあ

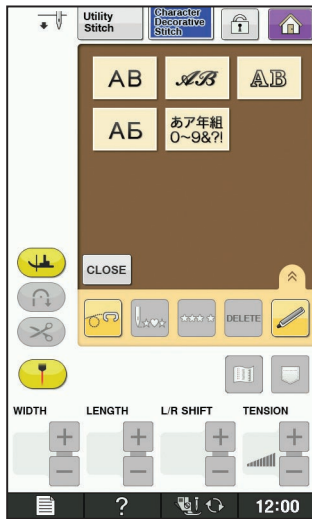

AB

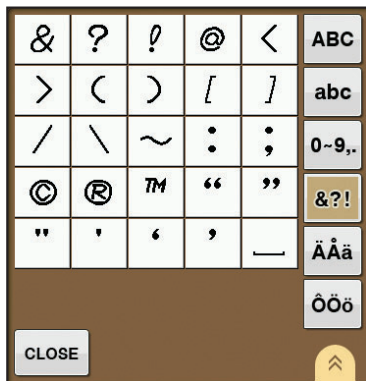

AB

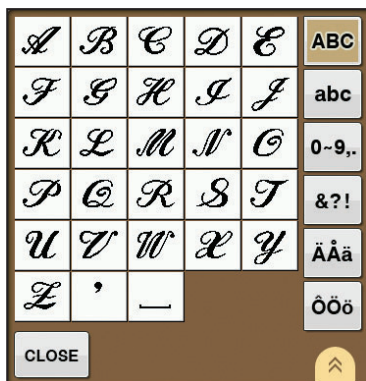

&	?	!	@	<	ABC
>	(	)	[	]	abc
/	\	~	:	;	0-9,.
©	®	™	“	”	&?! ÄÄä
”	’	‘	’	—	ÖÖö

CLOSE

À	Á	Â	à	á	ABC
ä	å	æ	ç	È	abc
É	Ê	ë	é	ê	0-9,.
Ë	Ï	ì	í	Ë	&?! ÄÄä
Ñ	ñ	í	—	—	ÖÖö

CLOSE

Ô	Õ	Ø	ò	ó	ABC
ô	ö	ø	ù	ú	abc
û	ü	Û	Ü	Ɔ	0-9,.
Ɔ	Ɔ	Ɔ	Ɔ	Ɔ	&?! ÄÄä
Ɔ	Ɔ	Ɔ	Ɔ	Ɔ	ÖÖö

CLOSE

AB

A	B	C	D	E	ABC
F	G	H	I	J	abc
K	L	M	N	O	0-9,.
P	Q	R	S	T	&?! ÄÄä
U	V	W	X	Y	ÖÖö
Z	’	—	—	—	—

CLOSE

a	b	c	d	e	ABC
f	g	h	i	j	abc
k	l	m	n	o	0-9,.
p	q	r	s	t	&?! ÄÄä
u	v	w	x	y	ÖÖö
z	’	—	—	—	—

CLOSE

0	1	2	3	4	ABC
5	6	7	8	9	abc
#	%	\$	£	€	0-9,.
¥	□	+	×	÷	&?! ÄÄä
≡	*	o	,	’	ÖÖö
—	—	—	—	—	—

CLOSE

&	?	!	@	<	ABC
>	(	)	[	]	abc
/	\	~	:	;	0-9,.
©	®	™	“	”	&?! ÄÄä
”	’	‘	’	—	ÖÖö

CLOSE

Â	Ã	Ä	à	á	ABC
â	ã	ä	á	â	abc
æ	Ç	ç	È	É	0-9,.
Ê	Ë	ë	é	ê	&?! ÄÄä
Ë	Ï	ì	í	Ë	ÖÖö
Ñ	ñ	í	—	—	—

CLOSE

Ô	Õ	Ø	ò	ó	ABC
ô	ö	ø	ù	ú	abc
û	ü	Û	Ü	Ɔ	0-9,.
Ɔ	Ɔ	Ɔ	Ɔ	Ɔ	&?! ÄÄä
Ɔ	Ɔ	Ɔ	Ɔ	Ɔ	ÖÖö

CLOSE

AB

А	Б	В	Г	Д	АБВ
Е	Ё	Ж	З	И	ЧШЩ
Й	К	Л	М	Н	абв
О	П	Р	С	Т	чшщ
У	Ф	Х	Ц	—	0-9,.

CLOSE

Ч	Ш	Щ	Ь	Ы	АБВ
ь	э	ю	я	Г	ЧШЩ
е	і	ї	ў	ґ	абв
ґ	Ј	Јь	Њ	Ц	чшщ
ґ	ѕ	ќ	—	—	0-9,.

CLOSE

a	б	в	г	д	АБВ
е	ё	ж	з	и	ЧШЩ
й	к	л	м	н	абв
о	п	р	с	т	чшщ
у	ф	х	ц	—	0-9,.

CLOSE

ч	ш	щ	ь	Ы	АБВ
б	э	ю	я	Г	ЧШЩ
ε	i	ï	ÿ	ћ	абв
ћ	Ј	ЈЬ	Ѓ	Ц	ЧШЩ
ƒ	s	ƚ	—		0~9,.

CLOSE ⬆

0	1	2	3	4	АБВ
5	6	7	8	9	ЧШЩ
—	.	,	&	?	абв
!	(	)	/	'	ЧШЩ
—					0~9,.

CLOSE ⬆

あア年組  
0~9&?! \*

あ <small>あ行</small>	か <small>か行</small>	さ <small>さ行</small>	た <small>た行</small>	な <small>な行</small>	あいう
は <small>は行</small>	ま <small>ま行</small>	や <small>や行</small>	ら <small>ら行</small>	わ <small>わ行</small>	アイウ
あ	い	う	え	お	0~九 &?! 年組
あ	い	う	え	お	—

CLOSE H V ⬆

ア <small>ア行</small>	カ <small>カ行</small>	サ <small>サ行</small>	タ <small>タ行</small>	ナ <small>ナ行</small>	あいう
ハ <small>ハ行</small>	マ <small>マ行</small>	ヤ <small>ヤ行</small>	ラ <small>ラ行</small>	ワ <small>ワ行</small>	アイウ
ア	イ	ウ	エ	オ	0~九 &?! 年組
ア	イ	ウ	エ	オ	—
	ヴ				

CLOSE H V ⬆

0	1	2	3	4	あいう
5	6	7	8	9	アイウ
0	—	二	三	四	0~九 &?! 年組
五	六	七	八	九	—
+	&	?	!	(	年組
)	—				—

CLOSE H V ⬆

生	年	月	日	才	あいう
小	中	学	校	組	アイウ
火	水	木	金	土	0~九 &?! 年組
				—	—

CLOSE H V ⬆

\* Japanese characters    \* 日語字符    \* 日文字符    \* 일본어 문자

◆ Embroidery Patterns

◆ 绣花花样

◆ 刺繡花樣

◆ 자수 패턴

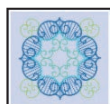
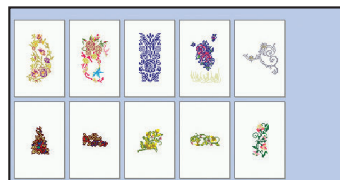
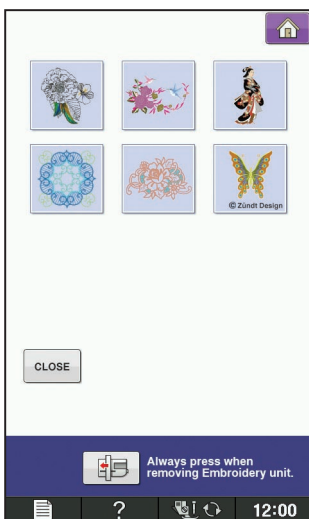
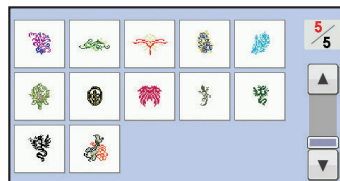
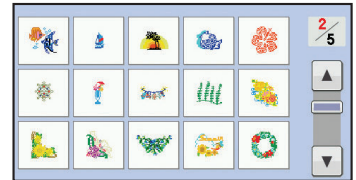
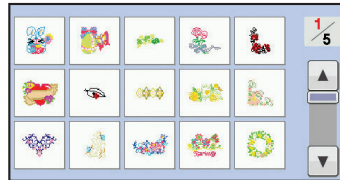
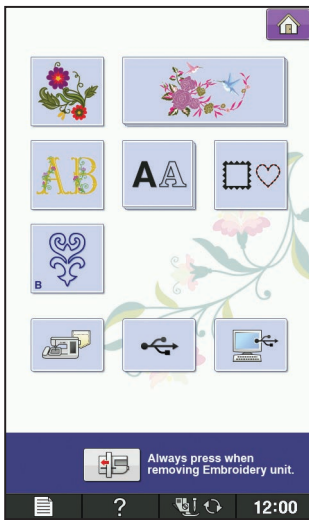

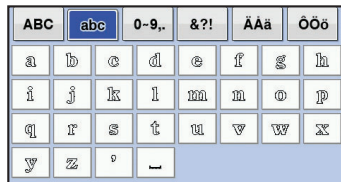
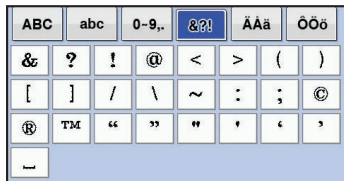
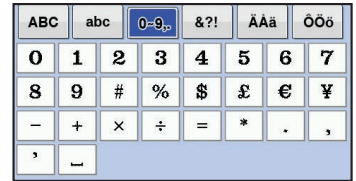
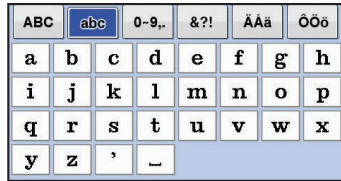
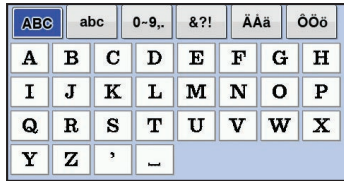
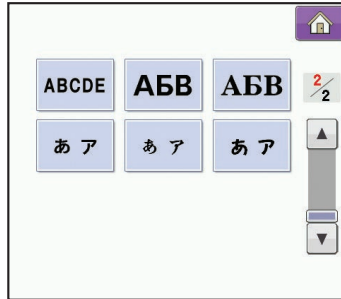
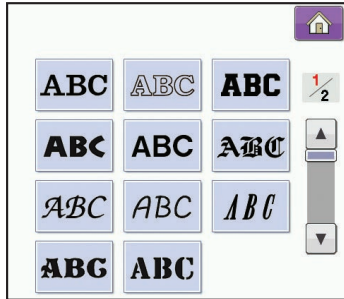
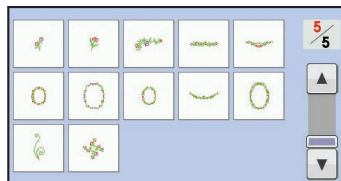
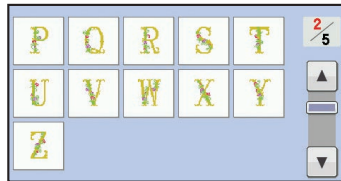
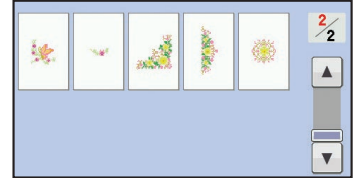
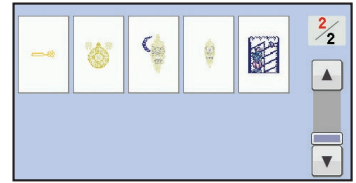
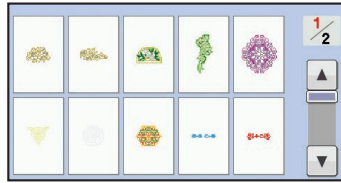



ABC

ABC	abc	0-9..	&?!	ÄÄä	ÖÖö		
&	?	!	@	<	>	(	)
[	]	/	\	~	:	:	©
®	™	“	”	“	”	‘	’
—							

ABC	abc	0-9..	&?!	ÄÄä	ÖÖö		
Â	Ã	Ä	à	á	â	ã	ä
å	Æ	æ	Ç	ç	È	É	Ê
Ë	è	é	ê	ë	Ï	ì	í
Ð	Ñ	ñ	’	—			

ABC	abc	0-9..	&?!	ÄÄä	ÖÖö		
Ô	Õ	Ø	ò	ó	ô	õ	ø
Ù	Û	ù	ú	û	ü	Þ	þ
ß	ı	İ	Ñ	Ó	ó	œ	œ
ř	ř	ž	’	—			

ABC	abc	0-9..	&?!	ÄÄä	ÖÖö		
A	B	C	D	E	F	G	H
I	J	K	L	M	N	O	P
Q	R	S	T	U	V	W	X
Y	Z	’	—				

ABC	abc	0-9..	&?!	ÄÄä	ÖÖö		
a	b	c	d	e	f	g	h
i	j	k	l	m	n	o	p
q	r	s	t	u	v	w	x
y	z	’	—				

ABC	abc	0-9..	&?!	ÄÄä	ÖÖö		
0	1	2	3	4	5	6	7
8	9	#	%	\$	£	€	¥
-	+	x	÷	=	*	.	.
’	—						

ABC	abc	0-9..	&?!	ÄÄä	ÖÖö		
&	?	!	@	<	>	(	)
[	]	/	\	~	:	:	©
®	™	“	”	“	”	‘	’
—							

ABC	abc	0-9..	&?!	ÄÄä	ÖÖö		
Â	Ã	Ä	à	á	â	ã	ä
å	Æ	æ	Ç	ç	È	É	Ê
Ë	è	é	ê	ë	Ï	ì	í
Ð	Ñ	ñ	’	—			

ABC	abc	0-9..	&?!	ÄÄä	ÖÖö		
Ô	Õ	Ø	ò	ó	ô	õ	ø
Ù	Û	ù	ú	û	ü	Þ	þ
ß	ı	İ	Ñ	Ó	ó	œ	œ
ř	ř	ž	’	—			

ABC

ABC	abc	0-9..	&?!	ÄÄä	ÖÖö		
A	B	C	D	E	F	G	H
I	J	K	L	M	N	O	P
Q	R	S	T	U	V	W	X
Y	Z	’	—				

ABC	abc	0-9..	&?!	ÄÄä	ÖÖö		
a	b	c	d	e	f	g	h
i	j	k	l	m	n	o	p
q	r	s	t	u	v	w	x
y	z	’	—				

ABC	abc	0-9..	&?!	ÄÄä	ÖÖö		
0	1	2	3	4	5	6	7
8	9	#	%	\$	£	€	¥
-	+	x	÷	=	*	.	,
’	—						

ABC	abc	0-9..	&?!	ÄÄä	ÖÖö		
&	?	!	@	<	>	(	)
[	]	/	\	~	:	:	©
®	™	“	”	“	”	‘	’
—							

ABC	abc	0-9..	&?!	ÄÄä	ÖÖö		
Â	Ã	Ä	à	á	â	ã	ä
å	Æ	æ	Ç	ç	È	É	Ê
Ë	è	é	ê	ë	Ï	ì	í
Ð	Ñ	ñ	’	—			

ABC	abc	0-9..	&?!	ÄÄä	ÖÖö		
Ô	Õ	Ø	ò	ó	ô	õ	ø
Ù	Û	ù	ú	û	ü	Þ	þ
ß	ı	İ	Ñ	Ó	ó	œ	œ
ř	ř	ž	’	—			

ABC

ABC	abc	0-9..	&?!	ÄÄä	ÖÖö		
A	B	C	D	E	F	G	H
I	J	K	L	M	N	O	P
Q	R	S	T	U	V	W	X
Y	Z	’	—				

ABC	abc	0-9..	&?!	ÄÄä	ÖÖö		
a	b	c	d	e	f	g	h
i	j	k	l	m	n	o	p
q	r	s	t	u	v	w	x
y	z	’	—				

ABC	abc	0-9..	&?!	ÄÄä	ÖÖö		
0	1	2	3	4	5	6	7
8	9	#	%	\$	£	€	¥
-	+	x	÷	=	*	.	,
’	—						

ABC	abc	0-9..	&?!	ÄÄä	ÖÖö		
&	?	!	@	<	>	(	)
[	]	/	\	~	:	:	©
®	™	“	”	“	”	‘	’
—							

ABC	abc	0-9..	&?!	ÄÄä	ÖÖö		
Â	Ã	Ä	à	á	â	ã	ä
å	Æ	æ	Ç	ç	È	É	Ê
Ë	è	é	ê	ë	Ï	ì	í
Ð	Ñ	ñ	’	—			

ABC	abc	0-9..	&?!	ÄÄä	ÖÖö		
Ô	Õ	Ø	ò	ó	ô	õ	ø
Ù	Û	ù	ú	û	ü	Þ	þ
ß	ı	İ	Ñ	Ó	ó	œ	œ
ř	ř	ž	’	—			

ABC

ABC	abc	0-9..	&?!				
À	Á	Â	Ã	Ä	Å	Æ	Ç
È	É	Ê	Ë	Ì	Í	Î	Ï
Ð	Ñ	Ò	Ó	Ô	Õ	Ö	×
Ù	Ú	Û	Ü	Ý	Þ	ß	—

ABC	abc	0-9..	&?!				
a	b	c	d	e	f	g	h
i	j	k	l	m	n	o	p
q	r	s	t	u	v	w	x
y	z	’	—				

ABC	abc	0-9..	&?!				
0	1	2	3	4	5	6	7
8	9	-	=	.	,	’	—

ABC	abc	0-9..	&?!				
&	?	!	<	>	[	]	/
\	~	:	:	“	”	‘	’
—							

ABC

ABC	abc	0-9..	&?!	ÄÄä	ÖÖö		
A	B	C	D	E	F	G	H
I	J	K	L	M	N	O	P
Q	R	S	T	U	V	W	X
Y	Z	'	-				

ABC	abc	0-9..	&?!	ÄÄä	ÖÖö		
a	b	c	d	e	f	g	h
i	j	k	l	m	n	o	p
q	r	s	t	u	v	w	x
y	z	'	-				

ABC	abc	0-9..	&?!	ÄÄä	ÖÖö		
0	1	2	3	4	5	6	7
8	9	#	%	\$	£	€	¥
-	+	x	÷	=	*	.	,
'	-						

ABC	abc	0-9..	&?!	ÄÄä	ÖÖö		
&	?	!	@	<	>	(	)
[	]	/	\	~	:	;	©
®	™	“	”	”	'	'	'
-							

ABC	abc	0-9..	&?!	ÄÄä	ÖÖö		
Ä	Ä	Ä	ä	á	â	ã	ä
å	Æ	æ	Ç	ç	È	É	Ê
Ë	è	é	ê	ë	Ï	ì	í
Ð	Ñ	ñ	'	-			

ABC	abc	0-9..	&?!	ÄÄä	ÖÖö		
Ô	Õ	Ø	ò	ó	ô	õ	ø
Ù	Ú	ù	ú	û	ü	Ɔ	Ɔ
ß	ı	İ	Ñ	Ö	ö	Œ	œ
ƒ	ƒ	ƒ	'	-			

ABC

ABC	abc	0-9..	&?!	ÄÄä	ÖÖö		
A	B	C	D	E	F	G	H
I	J	K	L	M	N	O	P
Q	R	S	T	U	V	W	X
Y	Z	'	-				

ABC	abc	0-9..	&?!	ÄÄä	ÖÖö		
a	b	c	d	e	f	g	h
i	j	k	l	m	n	o	p
q	r	s	t	u	v	w	x
y	z	'	-				

ABC	abc	0-9..	&?!	ÄÄä	ÖÖö		
0	1	2	3	4	5	6	7
8	9	#	%	\$	£	€	¥
-	+	x	÷	=	*	.	,
'	-						

ABC	abc	0-9..	&?!	ÄÄä	ÖÖö		
&	?	!	@	<	>	(	)
[	]	/	\	~	:	;	©
®	™	“	”	”	'	'	'
-							

ABC	abc	0-9..	&?!	ÄÄä	ÖÖö		
Â	Â	Â	à	á	â	ã	ä
å	Æ	æ	Ç	ç	È	É	Ê
Ë	è	é	ê	ë	Ï	ì	í
Ð	Ñ	ñ	'	-			

ABC	abc	0-9..	&?!	ÄÄä	ÖÖö		
Ô	Õ	Ø	ò	ó	ô	õ	ø
Ù	Ú	ù	ú	û	ü	Ɔ	Ɔ
ß	ı	İ	Ñ	Ö	ö	Œ	œ
ƒ	ƒ	ƒ	'	-			

ABC

ABC	abc	0-9..	&?!	ÄÄä	ÖÖö		
A	B	C	D	E	F	G	H
I	J	K	L	M	N	O	P
Q	R	S	T	U	V	W	X
Y	Z	'	-				

ABC	abc	0-9..	&?!	ÄÄä	ÖÖö		
a	b	c	d	e	f	g	h
i	j	k	l	m	n	o	p
q	r	s	t	u	v	w	x
y	z	'	-				

ABC	abc	0-9..	&?!	ÄÄä	ÖÖö		
0	1	2	3	4	5	6	7
8	9	#	%	\$	£	€	¥
-	+	x	÷	=	*	.	,
'	-						

ABC	abc	0-9..	&?!	ÄÄä	ÖÖö		
&	?	!	@	<	>	(	)
[	]	/	\	~	:	;	©
®	™	“	”	”	'	'	'
-							

ABC	abc	0-9..	&?!	ÄÄä	ÖÖö		
Á	Á	Á	à	á	â	ã	ä
å	Æ	æ	Ç	ç	È	É	Ê
Ë	è	é	ê	ë	Ï	ì	í
Ð	Ñ	ñ	'	-			

ABC	abc	0-9..	&?!	ÄÄä	ÖÖö		
Ô	Õ	Ø	ò	ó	ô	õ	ø
Ù	Ú	ù	ú	û	ü	Ɔ	Ɔ
ß	ı	İ	Ñ	Ö	ö	Œ	œ
ƒ	ƒ	ƒ	'	-			

ABC

ABC	abc	0-9..	&?!	ÄÄä	ÖÖö		
A	B	C	D	E	F	G	H
I	J	K	L	M	N	O	P
Q	R	S	T	U	V	W	X
Y	Z	'	-				

ABC	abc	0-9..	&?!	ÄÄä	ÖÖö		
a	b	c	d	e	f	g	h
i	j	k	l	m	n	o	p
q	r	s	t	u	v	w	x
y	z	'	-				

ABC	abc	0-9..	&?!	ÄÄä	ÖÖö		
0	1	2	3	4	5	6	7
8	9	#	%	\$	£	€	¥
-	+	x	÷	=	*	.	,
'	-						

ABC	abc	0-9..	&?!	ÄÄä	ÖÖö		
&	?	!	@	<	>	(	)
[	]	/	\	~	:	;	©
®	™	“	”	”	'	'	'
-							

ABC	abc	0-9..	&?!	ÄÄä	ÖÖö		
Â	Â	Â	à	á	â	ã	ä
å	Æ	æ	Ç	ç	È	É	Ê
Ë	è	é	ê	ë	Ï	ì	í
Ð	Ñ	ñ	'	-			

ABC	abc	0-9..	&?!	ÄÄä	ÖÖö		
Ô	Õ	Ø	ò	ó	ô	õ	ø
Ù	Ú	ù	ú	û	ü	Ɔ	Ɔ
ß	ı	İ	Ñ	Ö	ö	Œ	œ
ƒ	ƒ	ƒ	'	-			

ABC

ABC	abc	0-9..	&?!	ÄÄä	ÖÖö		
A	B	C	D	E	F	G	H
I	J	K	L	M	N	O	P
Q	R	S	T	U	V	W	X
Y	Z	'	-				

ABC	abc	0-9..	&?!	ÄÄä	ÖÖö		
a	b	c	d	e	f	g	h
i	j	k	l	m	n	o	p
q	r	s	t	u	v	w	x
y	z	'	-				

ABC	abc	0-9..	&?!	ÄÄä	ÖÖö		
0	1	2	3	4	5	6	7
8	9	#	%	\$	£	€	¥
-	+	x	÷	=	*	.	,
'	-						

ABCDE

ABC	abc	0-9..	&?! <b>&amp;?!</b>	ÄÄä	ÖÖö		
&	?	!	@	<	>	(	)
[	]	/	\	~	:	;	©
®	™	“	”	”	’	’	’
—							

ABC	abc	0-9..	&?! <b>ÄÄä</b>	ÖÖö			
Ä	Ä	Ä	à	á	â	ã	ä
å	Æ	æ	Ç	ç	È	É	Ê
Ë	è	é	ê	ë	Ï	ì	ï
Ð	Ñ	ñ	’	—			

ABC	abc	0-9..	&?! <b>ÄÄä</b>	ÖÖö			
Ó	Ô	Õ	ò	ó	ô	õ	ø
Ù	Û	ù	ú	û	ü	þ	ð
ß	ı	İ	Ń	Ō	ō	œ	œ
ř	ť	ž	’	—			

ABC	abc	0-9..	&?! <b>ÄÄä</b>	ÖÖö			
A	B	C	D	E	F	G	H
I	J	K	L	M	N	O	P
Q	R	S	T	U	V	W	X
Y	Z	’	—				

ABC	abc	0-9..	&?! <b>ÄÄä</b>	ÖÖö			
a	b	c	d	e	f	g	h
i	j	k	l	m	n	o	p
q	r	s	t	u	v	w	x
y	z	’	—				

ABC	abc	0-9..	&?! <b>ÄÄä</b>	ÖÖö			
0	1	2	3	4	5	6	7
8	9	#	%	\$	£	€	¥
-	+	x	÷	=	*	.	,
’	—						

ABC	abc	0-9..	&?! <b>&amp;?!</b>	ÄÄä	ÖÖö		
&	?	!	@	<	>	(	)
[	]	/	\	~	:	;	©
®	™	“	”	”	’	’	’
—							

ABC	abc	0-9..	&?! <b>ÄÄä</b>	ÖÖö			
Ä	Ä	Ä	à	á	â	ã	ä
å	Æ	æ	Ç	ç	È	É	Ê
Ë	è	é	ê	ë	Ï	ì	ï
Ð	Ñ	ñ	’	—			

ABC	abc	0-9..	&?! <b>ÄÄä</b>	ÖÖö			
Ó	Ô	Õ	ò	ó	ô	õ	ø
Ù	Û	ù	ú	û	ü	þ	ð
ß	ı	İ	Ń	Ō	ō	œ	œ
ř	ť	ž	’	—			

АБВ

АБВ	ЧШЦ	абв	чшц	0-9..			
А	Б	В	Г	Д	Е	Ё	Ж
З	И	Й	К	Л	М	Н	О
П	Р	С	Т	У	Ф	Х	Ц
—							

АБВ	ЧШЦ	абв	чшц	0-9..			
Ч	Ш	Щ	Ъ	Ы	Ь	Э	Ю
Я	Г	Є	І	Ї	Ў	Ғ	Ң
Ј	Љ	Њ	Џ	Ѓ	Ѕ	Ї	—

АБВ	ЧШЦ	абв	чшц	0-9..			
а	б	в	г	д	е	ё	ж
з	и	й	к	л	м	н	о
п	р	с	т	у	ф	х	ц
—							

АБВ	ЧШЦ	абв	чшц	0-9..			
ч	ш	щ	ъ	ы	ь	э	ю
я	г	є	і	ї	ў	ғ	ң
ј	љ	њ	џ	ѓ	ѕ	ѝ	—

АБВ	ЧШЦ	абв	чшц	0-9..			
0	1	2	3	4	5	6	7
8	9	-	.	,	&	?	!
(	)	/	’	—			

АБВ

АБВ	ЧШЦ	абв	чшц	0-9..			
А	Б	В	Г	Д	Е	Ё	Ж
З	И	Й	К	Л	М	Н	О
П	Р	С	Т	У	Ф	Х	Ц
—							

АБВ	ЧШЦ	абв	чшц	0-9..			
Ч	Ш	Щ	Ъ	Ы	Ь	Э	Ю
Я	Г	Є	І	Ї	Ў	Ғ	Ң
Ј	Љ	Њ	Џ	Ѓ	Ѕ	Ї	—

АБВ	ЧШЦ	абв	чшц	0-9..			
а	б	в	г	д	е	ё	ж
з	и	й	к	л	м	н	о
п	р	с	т	у	ф	х	ц
—							

АБВ	ЧШЦ	абв	чшц	0-9..			
ч	ш	щ	ъ	ы	ь	э	ю
я	г	є	і	ї	ў	ғ	ң
ј	љ	њ	џ	ѓ	ѕ	ѝ	—

АБВ	ЧШЦ	абв	чшц	0-9..			
0	1	2	3	4	5	6	7
8	9	-	.	,	&	?	!
(	)	/	’	—			

**あア** \*

Katakana characters: One of the character sets of Japanese.  
 Katakana 字符：日语字符集中的一种。  
 片假名字符：一種日文字符集。  
 가타카나 문자: 일본어 문자 집합의 하나.

Hiragana characters: One of the character sets of Japanese.  
 Hiragana 字符：日语字符集中的一种。  
 平假名字符：一種日文字符集。  
 히라가나 문자: 일본어 문자 집합의 하나.

Arabic numerals, Japanese Kanji numerals  
 阿拉伯数字、日本汉字数字  
 阿拉伯數字、日文漢字數字  
 아라비아 숫자, 일본어 간지 숫자

Kanji characters often used in daily life / symbols.  
 汉字字符常用于日常生活或符号。  
 漢字常用於日常生活 / 符號。  
 간지 문자는 일상 생활 / 기호에 자주 사용됩니다.



Horizontal  
 横向  
 水平  
 가로

Vertical  
 纵向  
 垂直  
 세로



あいう	アイウ	0-9 &?!	年組	H	V				
ア	カ	サ	タ	ナ	ハ	マ	ヤ	ラ	ワ
ラ	リ	ル	レ	ロ					

あいう	アイウ	0-9 &?!	年組	H	V				
ア	カ	サ	タ	ナ	ハ	マ	ヤ	ラ	ワ
ワ	ヲ	ン							

あいう	アイウ	0-9 &?!	年組	H	V				
0	1	2	3	4	5	6	7		
8	9	〇	一	二	三	四	五		
六	七	八	九	十					
&	?	!	(	)	-				

あいう	アイウ	0-9 &?!	年組	H	V				
生	年	月	日	才	小	中	学		
校	組	火	水	木	金	土	保		
育	幼	稚	園	番	部	班	会		
係	名	前							

あア \*

あいう	アイウ	0-9 &?!	年組	H	V				
あ	か	さ	た	な	は	ま	や	ら	わ
あ	い	う	え	お					
あ	い	う	え	お					

あいう	アイウ	0-9 &?!	年組	H	V				
あ	か	さ	た	な	は	ま	や	ら	わ
か	き	く	け	こ					
が	ぎ	ぐ	げ	ご					

あいう	アイウ	0-9 &?!	年組	H	V				
あ	か	さ	た	な	は	ま	や	ら	わ
さ	し	す	せ	そ					
ざ	じ	ず	ぜ	ぞ					

あいう	アイウ	0-9 &?!	年組	H	V				
あ	か	さ	た	な	は	ま	や	ら	わ
た	ち	つ	て	と					
だ	ぢ	づ	で	ど					
			っ						

あいう	アイウ	0-9 &?!	年組	H	V				
あ	か	さ	た	な	は	ま	や	ら	わ
な	に	ぬ	ね	の					

あいう	アイウ	0-9 &?!	年組	H	V				
あ	か	さ	た	な	は	ま	や	ら	わ
は	ひ	ふ	へ	ほ					
ば	び	ぶ	べ	ぼ					
ば	び	ぶ	べ	ぼ					

あいう	アイウ	0-9 &?!	年組	H	V				
あ	か	さ	た	な	は	ま	や	ら	わ
ま	み	む	め	も					

あいう	アイウ	0-9 &?!	年組	H	V				
あ	か	さ	た	な	は	ま	や	ら	わ
や	ゆ	よ							
や	ゆ	よ							

あいう	アイウ	0-9 &?!	年組	H	V				
あ	か	さ	た	な	は	ま	や	ら	わ
ら	り	る	れ	ろ					

あいう	アイウ	0-9 &?!	年組	H	V				
あ	か	さ	た	な	は	ま	や	ら	わ
わ	を	ん							

あいう	アイウ	0-9 &?!	年組	H	V				
ア	カ	サ	タ	ナ	ハ	マ	ヤ	ラ	ワ
ア	イ	ウ	エ	オ					
ア	イ	ウ	エ	オ					
			ヅ						

あいう	アイウ	0-9 &?!	年組	H	V				
ア	カ	サ	タ	ナ	ハ	マ	ヤ	ラ	ワ
カ	キ	ク	ケ	コ					
ガ	ギ	グ	ゲ	ゴ					

あいう	アイウ	0-9 &?!	年組	H	V				
ア	カ	サ	タ	ナ	ハ	マ	ヤ	ラ	ワ
サ	シ	ス	セ	ソ					
ザ	ジ	ズ	ゼ	ゾ					

あいう	アイウ	0-9 &?!	年組	H	V				
ア	カ	サ	タ	ナ	ハ	マ	ヤ	ラ	ワ
タ	チ	ツ	テ	ト					
ダ	ヂ	ヅ	デ	ド					
			ッ						

あいう	アイウ	0-9 &?!	年組	H	V				
ア	カ	サ	タ	ナ	ハ	マ	ヤ	ラ	ワ
ナ	ニ	ヌ	ネ	ノ					

あいう	アイウ	0-9 &?!	年組	H	V				
ア	カ	サ	タ	ナ	ハ	マ	ヤ	ラ	ワ
ハ	ヒ	フ	ヘ	ホ					
バ	ビ	ブ	ベ	ボ					
バ	ビ	ブ	ベ	ボ					

あいう	アイウ	0-9 &?!	年組	H	V				
ア	カ	サ	タ	ナ	ハ	マ	ヤ	ラ	ワ
マ	ミ	ム	メ	モ					

あいう	アイウ	0-9 &?!	年組	H	V				
ア	カ	サ	タ	ナ	ハ	マ	ヤ	ラ	ワ
ヤ	ユ	ヨ							
ヤ	ユ	ヨ							

\* Japanese characters    \* 日语字符    \* 日文字符    \* 일본어 문자

あいう	アイウ	0-9 &?!	年組	H	V				
ア	カ	サ	タ	ナ	ハ	マ	ヤ	ラ	ワ
ラ	リ	ル	レ	ロ					

あいう	アイウ	0-9 &?!	年組	H	V				
ア	カ	サ	タ	ナ	ハ	マ	ヤ	ラ	ワ
ワ	ラ	ン							

あいう	アイウ	0-9 &?!	年組	H	V				
0	1	2	3	4	5	6	7		
8	9	〇	一	二	三	四	五		
六	七	八	九	十					
&	?	!	(	)	-				

あいう	アイウ	0-9 &?!	年組	H	V				
生	年	月	日	オ	小	中	学		
校	組	火	水	木	金	土	保		
育	幼	稚	園	番	部	班	会		
係	名	前							

あア \*

あいう	アイウ	0-9 &?!	年組	H	V				
あ	か	さ	た	な	は	ま	や	ら	わ
あ	い	う	え	お					
あ	い	う	え	お					

あいう	アイウ	0-9 &?!	年組	H	V				
あ	か	さ	た	な	は	ま	や	ら	わ
か	き	く	け	こ					
が	ぎ	く	げ	ご					

あいう	アイウ	0-9 &?!	年組	H	V				
あ	か	さ	た	な	は	ま	や	ら	わ
さ	し	す	せ	そ					
ざ	じ	ず	ぜ	ぞ					

あいう	アイウ	0-9 &?!	年組	H	V				
あ	か	さ	た	な	は	ま	や	ら	わ
た	ち	つ	て	と					
だ	ぢ	づ	で	ど					
			っ						

あいう	アイウ	0-9 &?!	年組	H	V				
あ	か	さ	た	な	は	ま	や	ら	わ
な	に	ぬ	ね	の					

あいう	アイウ	0-9 &?!	年組	H	V				
あ	か	さ	た	な	は	ま	や	ら	わ
は	ひ	ふ	へ	ほ					
ば	び	ぶ	べ	ぼ					
ぱ	ぴ	ぷ	ぺ	ぽ					

あいう	アイウ	0-9 &?!	年組	H	V				
あ	か	さ	た	な	は	ま	や	ら	わ
ま	み	む	め	も					

あいう	アイウ	0-9 &?!	年組	H	V				
あ	か	さ	た	な	は	ま	や	ら	わ
や	ゆ	よ							
や	ゆ	よ							

あいう	アイウ	0-9 &?!	年組	H	V				
あ	か	さ	た	な	は	ま	や	ら	わ
ら	り	る	れ	ろ					

あいう	アイウ	0-9 &?!	年組	H	V				
あ	か	さ	た	な	は	ま	や	ら	わ
わ	ざ	ん							

あいう	アイウ	0-9 &?!	年組	H	V				
ア	カ	サ	タ	ナ	ハ	マ	ヤ	ラ	ワ
ア	イ	ウ	エ	オ					
ア	イ	ウ	エ	オ					
			ヴ						

あいう	アイウ	0-9 &?!	年組	H	V				
ア	カ	サ	タ	ナ	ハ	マ	ヤ	ラ	ワ
カ	キ	ク	ケ	コ					
ガ	ギ	グ	ゲ	ゴ					

あいう	アイウ	0-9 &?!	年組	H	V				
ア	カ	サ	タ	ナ	ハ	マ	ヤ	ラ	ワ
サ	シ	ス	セ	ソ					
ザ	ジ	ズ	ゼ	ゾ					

あいう	アイウ	0-9 &?!	年組	H	V				
ア	カ	サ	タ	ナ	ハ	マ	ヤ	ラ	ワ
タ	チ	ツ	テ	ト					
ダ	ヂ	ヅ	デ	ド					
			ッ						

あいう	アイウ	0-9 &?!	年組	H	V				
ア	カ	サ	タ	ナ	ハ	マ	ヤ	ラ	ワ
ナ	ニ	ヌ	ネ	ノ					

あいう	アイウ	0-9 &?!	年組	H	V				
ア	カ	サ	タ	ナ	ハ	マ	ヤ	ラ	ワ
ハ	ヒ	フ	ヘ	ホ					
バ	ビ	ブ	ベ	ボ					
パ	ピ	プ	ペ	ポ					

あいう	アイウ	0-9 &?!	年組	H	V				
ア	カ	サ	タ	ナ	ハ	マ	ヤ	ラ	ワ
マ	ミ	ム	メ	モ					

あいう	アイウ	0-9 &?!	年組	H	V				
ア	カ	サ	タ	ナ	ハ	マ	ヤ	ラ	ワ
ヤ	ユ	ヨ							
ヤ	ユ	ヨ							

\* Japanese characters

\* 日语字符

\* 日文字符

\* 일본어 문자

あいう アイウ 0-9 &?! 年組 H V

ア	カ	サ	タ	ナ	ハ	マ	ヤ	ラ	ワ
行	行	行	行	行	行	行	行	行	行
ラ	リ	ル	レ	ロ					

あいう アイウ 0-9 &?! 年組 H V

ア	カ	サ	タ	ナ	ハ	マ	ヤ	ラ	ワ
行	行	行	行	行	行	行	行	行	行
ワ	ヲ	ン							

あいう アイウ 0-9 &?! 年組 H V

0	1	2	3	4	5	6	7
8	9	〇	ー	ニ	三	四	五
六	七	八	九	十			
&	?	!	(	)	ー		ー

あいう アイウ 0-9 &?! 年組 H V

生	年	月	日	才	小	中	学
校	組	火	水	木	金	土	保
育	幼	稚	園	番	部	班	会
係	名	前					ー

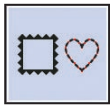

○ □ ◇ ○ □ ▽ ○ ▽ □

○	○	○	○	○
○	○	○	○	○
○	○	○	○	○

○ □ ◇ ○ □ ▽ ○ ▽ □

□	□	□	□	□
□	□	□	□	□
□	□	□	□	□

○ □ ◇ ○ □ ▽ ○ ▽ □

◇	◇	◇	◇	◇
◇	◇	◇	◇	◇
◇	◇	◇	◇	◇

○ □ ◇ ○ □ ▽ ○ ▽ □

○	○	○	○	○
○	○	○	○	○
○	○	○	○	○

○ □ ◇ ○ □ ▽ ○ ▽ □

□	□	□	□	□
□	□	□	□	□
□	□	□	□	□

○ □ ◇ ○ □ ▽ ○ ▽ □

▽	▽	▽	▽	▽
▽	▽	▽	▽	▽
▽	▽	▽	▽	▽

○ □ ◇ ○ □ ▽ ○ ▽ □

♥	♥	♥	♥	♥
♥	♥	♥	♥	♥
♥	♥	♥	♥	♥

○ □ ◇ ○ □ ▽ ○ ▽ □

○	○	○	○	○
○	○	○	○	○
○	○	○	○	○

○ □ ◇ ○ □ ▽ ○ ▽ □

▽	▽	▽	▽	▽
▽	▽	▽	▽	▽
▽	▽	▽	▽	▽

○ □ ◇ ○ □ ▽ ○ ▽ □

□	□	□	□	□
□	□	□	□	□
□	□	□	□	□



1/2

2/2

--	--	--

# Embroidery Pattern Color Change Table

## 绣花花样颜色变更表

## 刺繡花樣顏色轉換表

## 자수 패턴 색 변경 표

### ◆ Embroidery patterns

### ◆ 绣花花样

### ◆ 刺繡花樣

### ◆ 자수 패턴



#### ● "Four Seasons" designs

- “四季” 设计
- 「四季」 設計
- “사계절” 디자인



Order to embroider  
绣制顺序  
刺繡順序  
자수 순서

Embroidery thread color  
绣花线色  
繡線顏色  
자수 실 색

No.1 13 min	
1	(124)
2	(001)
3	(086)
4	(001)
5	(017)
6	(612)
7	(085)
8	(205)
9	(019)
10	(900)
↕	67.2 mm
↔	66.3 mm

Time required for embroidering  
绣花需要的时间  
刺繡所需的時間  
자수에 필요한 시간

Embroidery thread color number  
绣花线色编号  
繡線顏色編號  
자수 실 색 번호

Embroidery size  
绣花大小  
刺繡尺寸  
자수 크기

No.8 7 min	
1	(502)
2	(812)
3	(079)
4	(328)
5	(330)
6	(126)
7	(206)
8	(328)
↕	40.8 mm
↔	83.1 mm



No.9 15 min	
1	(502)
2	(513)
3	(812)
4	(348)
5	(126)
6	(206)
7	(348)
8	(843)
↕	57.7 mm
↔	104.2 mm



No.10 12 min	
1	(124)
2	(513)
3	(005)
4	(079)
5	(086)
6	(206)
↕	90.9 mm
↔	90.5 mm



No.2 11 min	
1	(027)
2	(612)
3	(070)
4	(502)
5	(019)
6	(085)
7	(206)
8	(086)
9	(001)
10	(070)
↕	52.4 mm
↔	63.0 mm



No.5 6 min	
1	(900)
2	(800)
↕	145.6 mm
↔	112.0 mm



No.11 9 min	
1	(406)
2	(810)
3	(085)
4	(202)
↕	66.0 mm
↔	99.7 mm



No.3 3 min	
1	(812)
2	(027)
3	(515)
4	(513)
↕	27.7 mm
↔	56.7 mm



No.6 13 min					
1	(124)	7	(509)	13	(613)
2	(800)	8	(613)	14	(612)
3	(001)	9	(612)	15	(613)
4	(807)	10	(206)	16	(206)
5	(348)	11	(612)		
6	(206)	12	(509)		
↕ 56.0 mm ↔ 74.8 mm					



No.4 5 min	
1	(807)
2	(515)
3	(001)
4	(017)
5	(070)
↕	61.6 mm
↔	76.9 mm



No.7 1 min	
1	(900)
2	(800)
↕	20.4 mm
↔	38.0 mm



No.12 20 min	
1	(399)
2	(337)
3	(001)
4	(017)
5	(405)
↕	150.3 mm
↔	112.8 mm







No.13

27 min		
1 (420)	11 (420)	21 (085)
2 (017)	12 (086)	22 (086)
3 (086)	13 (807)	23 (807)
4 (807)	14 (085)	24 (085)
5 (085)	15 (612)	25 (807)
6 (612)	16 (804)	26 (612)
7 (804)	17 (206)	27 (804)
8 (206)	18 (807)	28 (206)
9 (807)	19 (420)	
10 (017)	20 (017)	
↓ 105.9 mm ↔ 158.6 mm		



No.14

15 min		
1 (509)	6 (502)	11 (001)
2 (206)	7 (509)	12 (017)
3 (001)	8 (086)	13 (086)
4 (124)	9 (502)	
5 (017)	10 (509)	
↓ 68.1 mm ↔ 98.3 mm		



No.15

43 min	
1 (509)	
2 (513)	
3 (502)	
4 (079)	
5 (001)	
6 (206)	
7 (208)	
8 (513)	
9 (502)	
10 (509)	
↓ 129.4 mm ↔ 131.5 mm	



No.16

14 min	
1 (001)	
2 (019)	
3 (205)	
4 (209)	
5 (085)	
6 (030)	
7 (900)	
8 (405)	
9 (339)	
↓ 76.5 mm ↔ 69.9 mm	



No.17

2 min	
1 (800)	
2 (019)	
3 (001)	
4 (420)	
↓ 28.9 mm ↔ 18.9 mm	



No.18

13 min	
1 (030)	
2 (209)	
3 (208)	
4 (206)	
5 (202)	
6 (900)	
↓ 50.9 mm ↔ 74.5 mm	



No.19

11 min	
1 (017)	
2 (001)	
3 (405)	
↓ 56.4 mm ↔ 70.0 mm	



No.20

10 min	
1 (030)	
↓ 76.8 mm ↔ 77.6 mm	

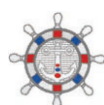

No.21

7 min	
1 (001)	
2 (005)	
3 (405)	
4 (800)	
5 (001)	
6 (817)	
↓ 50.2 mm ↔ 50.2 mm	



No.22

5 min	
1 (001)	7 (126)
2 (017)	8 (612)
3 (502)	9 (800)
4 (086)	10 (086)
5 (202)	11 (001)
6 (019)	
↓ 63.0 mm ↔ 29.7 mm	



No.23

10 min		
1 (030)	5 (005)	9 (001)
2 (019)	6 (017)	10 (405)
3 (001)	7 (019)	11 (030)
4 (405)	8 (206)	12 (017)
↓ 48.4 mm ↔ 91.4 mm		



No.24

3 min	
1 (534)	
↓ 57.3 mm ↔ 64.8 mm	



No.25

21 min		
1 (019)	6 (086)	11 (085)
2 (515)	7 (206)	12 (086)
3 (513)	8 (019)	13 (206)
4 (209)	9 (515)	
5 (085)	10 (513)	
↓ 82.7 mm ↔ 85.3 mm		



No.26

18 min		
1 (001)	9 (001)	17 (001)
2 (323)	10 (323)	18 (323)
3 (513)	11 (513)	19 (507)
4 (507)	12 (507)	20 (513)
5 (513)	13 (513)	21 (206)
6 (206)	14 (206)	22 (208)
7 (208)	15 (208)	23 (328)
8 (328)	16 (328)	
↓ 76.3 mm ↔ 76.4 mm		



No.27

15 min	
1 (399)	
2 (534)	
3 (810)	
4 (399)	
5 (070)	
6 (614)	
7 (086)	
↓ 87.3 mm ↔ 89.2 mm	



No.28

19 min		
1 (202)	7 (202)	13 (202)
2 (406)	8 (406)	14 (406)
3 (019)	9 (019)	15 (019)
4 (513)	10 (513)	16 (513)
5 (515)	11 (515)	17 (515)
6 (519)	12 (519)	18 (519)
↓ 76.8 mm ↔ 130.5 mm		



No.29

15 min		
1 (509)	5 (328)	9 (206)
2 (030)	6 (337)	10 (126)
3 (206)	7 (323)	
4 (126)	8 (017)	
↓ 73.2 mm ↔ 93.0 mm		



No.34

12 min		
1 (214)	5 (515)	9 (612)
2 (323)	6 (513)	10 (620)
3 (339)	7 (209)	11 (339)
4 (030)	8 (208)	
↓ 52.8 mm ↔ 69.3 mm		



No.40

18 min	
1 (517)	2 (323)
3 (214)	4 (348)
5 (800)	6 (214)
7 (330)	8 (030)
9 (214)	
↓ 88.9 mm ↔ 112.0 mm	



No.30

44 min		
1 (507)	7 (107)	13 (001)
2 (534)	8 (202)	14 (017)
3 (507)	9 (206)	15 (800)
4 (001)	10 (507)	16 (107)
5 (017)	11 (534)	17 (202)
6 (800)	12 (507)	18 (206)
↓ 123.2 mm ↔ 120.6 mm		



No.35

7 min		
1 (010)	5 (205)	9 (405)
2 (027)	6 (900)	10 (030)
3 (001)	7 (030)	
4 (620)	8 (339)	
↓ 60.6 mm ↔ 68.2 mm		



No.41

13 min	
1 (307)	2 (517)
3 (513)	4 (515)
5 (612)	6 (807)
7 (517)	8 (812)
↓ 74.3 mm ↔ 75.8 mm	



No.42



No.31

17 min	
1 (001)	2 (843)
3 (328)	4 (323)
5 (058)	6 (900)
↓ 93.1 mm ↔ 52.7 mm	



No.36

3 min	
1 (214)	2 (800)
3 (339)	
↓ 22.0 mm ↔ 81.2 mm	



No.37

7 min	
1 (328)	2 (323)
3 (415)	4 (339)
5 (517)	6 (307)
↓ 45.8 mm ↔ 53.4 mm	



No.32

25 min	
1 (205)	2 (900)
3 (707)	4 (001)
5 (707)	6 (005)
7 (070)	8 (030)
9 (900)	
↓ 77.5 mm ↔ 74.1 mm	



No.38

10 min	
1 (348)	2 (337)
3 (330)	4 (517)
5 (214)	6 (323)
7 (107)	
↓ 75.0 mm ↔ 76.2 mm	



No.33

3 min	
1 (058)	2 (209)
3 (202)	4 (323)
5 (513)	6 (515)
↓ 30.1 mm ↔ 33.0 mm	



No.39

4 min	
1 (107)	
↓ 79.2 mm ↔ 79.2 mm	



No.43

42 min		
1 (399)	12 (328)	23 (339)
2 (328)	13 (517)	24 (542)
3 (206)	14 (206)	25 (517)
4 (337)	15 (339)	26 (058)
5 (339)	16 (337)	27 (399)
6 (517)	17 (542)	28 (206)
7 (328)	18 (058)	29 (517)
8 (058)	19 (542)	30 (339)
9 (542)	20 (399)	31 (328)
10 (399)	21 (328)	32 (058)
11 (058)	22 (206)	33 (542)
↓ 148.1 mm ↔ 114.0 mm		

No.44



15 min		
1 (348)	6 (058)	11 (058)
2 (214)	7 (208)	12 (348)
3 (126)	8 (214)	13 (339)
4 (208)	9 (126)	
5 (513)	10 (348)	

↓ 55.9 mm ↔ 122.9 mm

No.45



38 min		
1 (348)	12 (348)	23 (517)
2 (214)	13 (314)	24 (348)
3 (515)	14 (333)	25 (214)
4 (214)	15 (328)	26 (515)
5 (333)	16 (323)	27 (328)
6 (517)	17 (515)	28 (323)
7 (323)	18 (214)	29 (058)
8 (058)	19 (517)	30 (214)
9 (348)	20 (323)	
10 (515)	21 (348)	
11 (517)	22 (333)	

↓ 123.4 mm ↔ 123.6 mm

No.46



20 min		
1 (800)	6 (843)	11 (079)
2 (620)	7 (307)	12 (800)
3 (124)	8 (515)	13 (620)
4 (079)	9 (339)	14 (515)
5 (001)	10 (124)	

↓ 72.4 mm ↔ 95.5 mm

No.47



12 min		
1 (406)	5 (513)	9 (086)
2 (507)	6 (612)	10 (328)
3 (513)	7 (019)	11 (800)
4 (205)	8 (001)	12 (205)

↓ 56.1 mm ↔ 71.7 mm

No.48



4 min	
1 (323)	2 (208)
3 (507)	4 (800)

↓ 49.4 mm  
↔ 40.2 mm

No.49



8 min	
1 (001)	2 (017)
3 (206)	4 (807)
5 (612)	6 (515)

↓ 54.5 mm  
↔ 76.3 mm

No.50



9 min	
1 (405)	2 (328)
3 (107)	

↓ 88.2 mm  
↔ 92.2 mm

No.51



6 min	
1 (001)	4 (214)
2 (800)	5 (209)
3 (817)	6 (900)

↓ 60.8 mm ↔ 30.4 mm

No.52



10 min	
1 (214)	2 (800)

↓ 96.2 mm  
↔ 61.3 mm

No.53



6 min	
1 (030)	

↓ 77.8 mm  
↔ 75.2 mm

No.54



2 min	
1 (214)	2 (509)
3 (800)	

↓ 64.9 mm  
↔ 21.2 mm

No.55



12 min	
1 (058)	2 (515)
3 (800)	4 (206)
5 (323)	6 (058)
7 (534)	

↓ 56.0 mm  
↔ 89.4 mm

No.56



10 min	
1 (507)	2 (328)
3 (001)	4 (800)
5 (328)	

↓ 52.8 mm  
↔ 98.5 mm

No.57



16 min	
1 (328)	2 (348)
3 (126)	4 (206)
5 (107)	6 (001)
7 (507)	8 (328)
9 (107)	

↓ 92.4 mm  
↔ 90.7 mm

No.58



9 min		
1 (542)	5 (542)	9 (415)
2 (323)	6 (323)	10 (323)
3 (415)	7 (415)	11 (406)
4 (323)	8 (323)	12 (205)

↓ 91.6 mm ↔ 90.1 mm

No.59



12 min		
1 (058)	5 (001)	9 (019)
2 (307)	6 (058)	10 (030)
3 (206)	7 (507)	11 (017)
4 (019)	8 (800)	

↓ 75.1 mm ↔ 100.1 mm

No.60



22 min	
1 (399)	2 (348)
3 (507)	4 (800)
5 (348)	6 (507)
7 (800)	8 (348)

↓ 95.8 mm  
↔ 102.3 mm

- "Other" designs
- "其它" 设计
- 「其他」 設計
- "기타" 디자인

**No.61** **9 min**



1	(614)
2	(620)
3	(405)
↓	82.4 mm
↔	91.2 mm

**No.65** **8 min**



1	(019)
2	(017)
3	(019)
↓	69.9 mm
↔	67.1 mm

**★ No.69** **4 min / 2 min**



1	(707)
↓	75.0 mm
L: ↔	43.3 mm
↓	45.9 mm
S: ↔	26.9 mm

**No.62** **5 min**



1	(399)
2	(808)
3	(509)
↓	42.5 mm
↔	100.9 mm

**★ No.66** **38 min / 19 min**



1	(843)
2	(614)
3	(517)
4	(843)
5	(517)
6	(843)
7	(517)
8	(843)
9	(614)
↓	154.1 mm
L: ↔	118.7 mm
↓	96.6 mm
S: ↔	73.4 mm

**No.70** **8 min**



1	(519)
2	(704)
3	(800)
4	(542)
5	(519)
6	(704)
↓	84.0 mm
↔	59.7 mm

**★ No.63** **8 min / 4 min**



1	(843)
2	(399)
3	(800)
↓	99.0 mm
L: ↔	151.0 mm
↓	58.6 mm
S: ↔	89.0 mm



**No.67** **10 min**



1	(328)
2	(900)
3	(328)
4	(900)
↓	55.1 mm
↔	45.9 mm

**No.71** **22 min**



1	(900)
2	(704)
3	(800)
4	(005)
5	(900)
6	(704)
↓	140.5 mm
↔	119.1 mm

**No.64** **11 min**



1	(001)
2	(328)
3	(406)
4	(328)
5	(019)
↓	93.0 mm
↔	70.6 mm

**No.68** **11 min**



1	(107)
↓	68.2 mm
↔	77.3 mm

**No.72** **26 min**



1	(001)
2	(817)
3	(900)
4	(001)
5	(030)
↓	120.9 mm
↔	99.8 mm

Patterns marked with ★ are in large and small sizes. Make your selection prior to touching embroidery.  
 帶有 ★ 标记的花样有大尺寸和小尺寸。触摸绣花花样前，请确认所选花样大小。  
 以★標記的花樣有大小兩種尺寸。壓按刺繡前先選擇。  
 ★ 표시 패턴은 큰 크기와 작은 크기가 있습니다. 자수를 터치하기 전에 선택하세요.

◆ Brother “Exclusives” Trend designs

◆ Brother “独家” 趋势设计

◆ Brother 「專屬」 流行設計

◆ 부라더 “전용” 트렌드 디자인

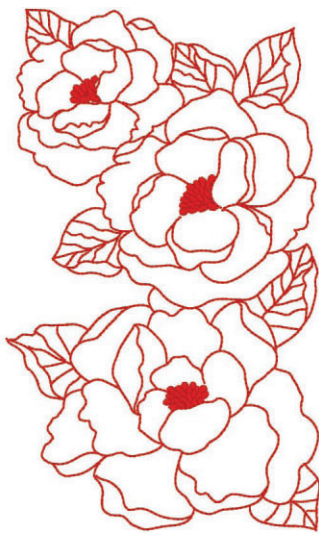
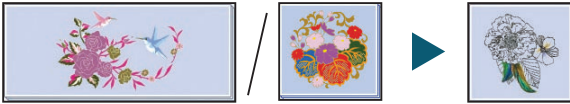

**No.1** **28 min**

1	(800)
↕	276.0 mm
↔	165.8 mm



**No.4** **84 min**

1	(001)	17	(017)
2	(399)	18	(001)
3	(405)	19	(405)
4	(017)	20	(017)
5	(399)	21	(399)
6	(001)	22	(001)
7	(405)	23	(399)
8	(399)	24	(001)
9	(017)	25	(405)
10	(001)	26	(017)
11	(399)	27	(001)
12	(405)	28	(405)
13	(017)	29	(017)
14	(405)	30	(405)
15	(001)	31	(399)
16	(399)	32	(001)
↕ 264.0 mm ↔ 164.4 mm			



**No.2** **29 min**

1	(900)	7	(328)	13	(415)
2	(534)	8	(509)	14	(507)
3	(420)	9	(208)	15	(070)
4	(509)	10	(534)	16	(206)
5	(507)	11	(515)	17	(900)
6	(415)	12	(517)		
↕ 181.9 mm ↔ 169.4 mm					



**No.5** **12 min**

1	(330)
↕	231.6 mm
↔	138.4 mm



**No.3** **39 min**

1	(206)	6	(810)	11	(086)
2	(502)	7	(607)	12	(502)
3	(607)	8	(707)	13	(707)
4	(086)	9	(206)		
5	(707)	10	(607)		
↕ 150.3 mm ↔ 146.3 mm					

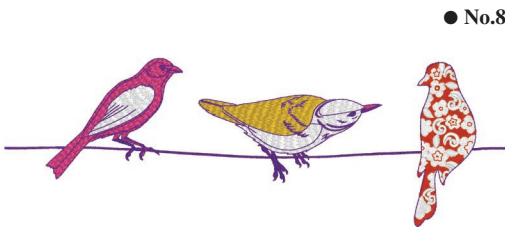
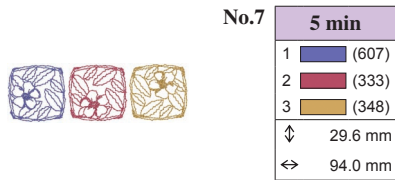

32 min	
1	(086)
2	(001)
3	(613)
4	(614)
5	(001)
6	(208)
7	(086)
8	(613)
9	(614)
10	(030)
11	(001)
12	(613)
13	(030)
↕	266.6 mm
↔	89.1 mm

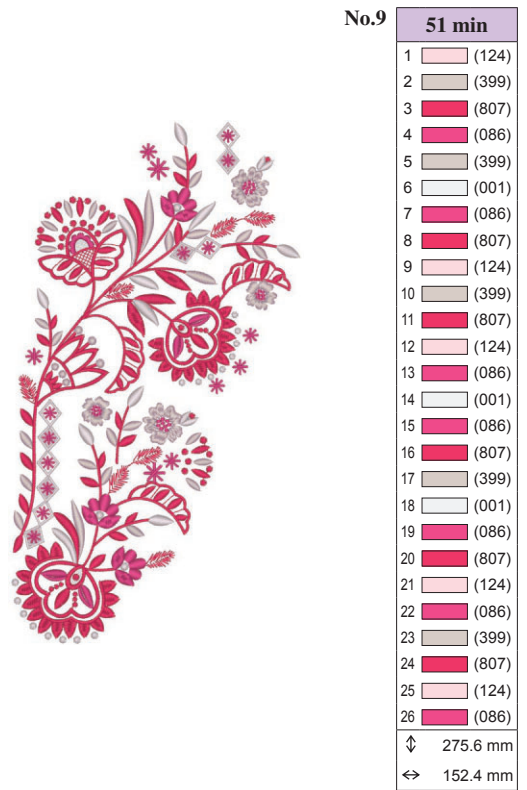

Patterns marked with ● have been rotated. Check your design placement prior to embroidering.

已旋轉帶有●标记的花样。绣花前检查您的设计布局。

以●標記的花樣已旋轉。刺繡前先檢查設計位置。

● 표시 패턴은 회전된 상태입니다. 자수 놓기 전에 디자인 배치를 확인하세요.

◆ Brother “Exclusives” Vintage designs

◆ Brother “独家” 复古设计

◆ Brother 「專屬」復古設計

◆ 부라더 “전용” 빈티지 디자인

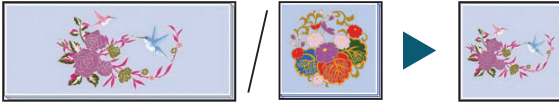

● No.1



68 min			
1 (348)	9 (126)	17 (348)	25 (328)
2 (333)	10 (348)	18 (333)	26 (843)
3 (328)	11 (869)	19 (328)	27 (124)
4 (843)	12 (328)	20 (843)	28 (079)
5 (124)	13 (333)	21 (124)	29 (333)
6 (079)	14 (843)	22 (348)	30 (869)
7 (333)	15 (126)	23 (869)	31 (126)
8 (869)	16 (124)	24 (333)	
↓ 272.4 mm ↔ 160.6 mm			

No.3

45 min	
1	(406)
↓	285.8 mm
↔	133.8 mm



● No.2



78 min			
1 (807)	11 (517)	21 (333)	31 (843)
2 (333)	12 (333)	22 (843)	32 (019)
3 (328)	13 (328)	23 (001)	33 (517)
4 (085)	14 (843)	24 (079)	34 (328)
5 (843)	15 (807)	25 (843)	35 (807)
6 (328)	16 (517)	26 (085)	36 (328)
7 (085)	17 (079)	27 (517)	37 (085)
8 (807)	18 (328)	28 (328)	38 (843)
9 (328)	19 (001)	29 (001)	39 (085)
10 (001)	20 (517)	30 (017)	40 (328)
↓ 263.2 mm ↔ 164.2 mm			

No.4

26 min	
1	(107)
2	(085)
3	(086)
4	(406)
5	(513)
6	(017)
7	(607)
8	(406)
9	(513)
10	(017)
11	(607)
12	(406)
13	(513)
14	(017)
15	(607)
16	(085)
17	(086)
18	(107)
19	(406)
20	(399)
↓	287.0 mm
↔	170.5 mm



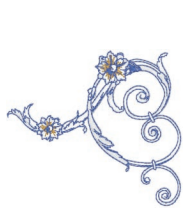

No.5		9 min	
1	(001)		
2	(348)		
3	(070)		
4	(001)		
5	(348)		
6	(070)		
↓		82.0 mm	
↔		91.8 mm	



No.7		14 min	
1	(800)		
2	(534)		
3	(405)		
4	(348)		
5	(058)		
↓		41.6 mm	
↔		74.6 mm	



No.9		9 min	
1	(517)		
2	(206)		
3	(323)		
4	(333)		
↓		44.1 mm	
↔		103.0 mm	



No.6		17 min	
1	(800)		
2	(534)		
3	(405)		
4	(800)		
5	(348)		
6	(058)		
↓		81.2 mm	
↔		57.2 mm	



No.8		8 min	
1	(517)		
2	(010)		
3	(206)		
4	(323)		
5	(333)		
↓		60.5 mm	
↔		66.1 mm	



No.10		12 min	
1	(515)		
2	(415)		
3	(399)		
4	(124)		
5	(085)		
6	(086)		
7	(415)		
8	(202)		
↓		123.3 mm	
↔		64.0 mm	

◆ Brother “Exclusives” Japanese designs

◆ Brother “独家” 日式风格设计

◆ Brother 「専属」 日式設計

◆ 부라더 “전용” 일본 디자인

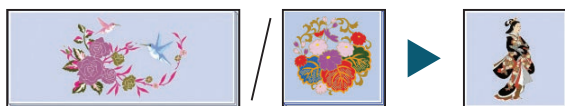

● No.1

No.1		99 min					
1	(208)	14	(202)	27	(017)	40	(900)
2	(509)	15	(017)	28	(509)	41	(800)
3	(001)	16	(509)	29	(607)	42	(001)
4	(202)	17	(800)	30	(800)	43	(208)
5	(017)	18	(900)	31	(900)	44	(607)
6	(509)	19	(001)	32	(001)	45	(017)
7	(208)	20	(017)	33	(202)	46	(509)
8	(079)	21	(800)	34	(208)	47	(800)
9	(800)	22	(509)	35	(900)	48	(001)
10	(900)	23	(900)	36	(509)	49	(208)
11	(001)	24	(001)	37	(017)	50	(607)
12	(079)	25	(079)	38	(079)	51	(017)
13	(607)	26	(202)	39	(800)	52	(509)
↓						287.2 mm ↔ 172.6 mm	

Patterns marked with ● have been rotated. Check your design placement prior to embroidering.

已旋转带有 ● 标记的花样。 绣花前检查您的设计布局。

以 ● 標記的花樣已旋轉。 刺繡前先檢查設計位置。

● 표시 패턴은 회전된 상태입니다. 자수 놓기 전에 디자인 배치를 확인하세요.



Embroidery Pattern Color Change Table

绣花花样颜色变更表

刺繡花樣顏色轉換表

자수 패턴 색 변경 표

No.2



94 min		
1 (030)	22 (542)	43 (001)
2 (507)	23 (612)	44 (307)
3 (348)	24 (406)	45 (208)
4 (323)	25 (208)	46 (328)
5 (001)	26 (900)	47 (406)
6 (542)	27 (328)	48 (542)
7 (612)	28 (406)	49 (900)
8 (323)	29 (030)	50 (030)
9 (406)	30 (507)	51 (507)
10 (208)	31 (001)	52 (399)
11 (900)	32 (348)	53 (001)
12 (704)	33 (612)	54 (612)
13 (328)	34 (542)	55 (542)
14 (406)	35 (208)	56 (208)
15 (307)	36 (323)	57 (307)
16 (030)	37 (406)	58 (348)
17 (507)	38 (900)	59 (420)
18 (001)	39 (030)	60 (323)
19 (399)	40 (507)	61 (406)
20 (348)	41 (328)	62 (900)
21 (323)	42 (323)	

↓ 244.4 mm ↔ 123.5 mm

No.6



9 min	
1 (415)	
2 (399)	
3 (323)	
4 (800)	
5 (005)	
6 (399)	
7 (328)	

↓ 63.2 mm  
↔ 117.0 mm

No.7



18 min	
1 (001)	6 (030)
2 (058)	7 (209)
3 (515)	8 (001)
4 (517)	9 (399)
5 (800)	10 (208)

↓ 84.0 mm ↔ 78.2 mm

No.3



73 min		
1 (030)	8 (214)	15 (328)
2 (515)	9 (328)	16 (810)
3 (019)	10 (030)	17 (612)
4 (328)	11 (612)	18 (030)
5 (810)	12 (206)	19 (348)
6 (206)	13 (810)	20 (206)
7 (348)	14 (348)	21 (348)

↓ 152.1 mm ↔ 151.0 mm

No.8



18 min	
1 (328)	
2 (058)	
3 (515)	
4 (519)	
5 (330)	
6 (058)	
7 (337)	
8 (348)	
9 (079)	
10 (086)	
11 (058)	
12 (010)	

↓ 140.6 mm  
↔ 62.3 mm

No.4

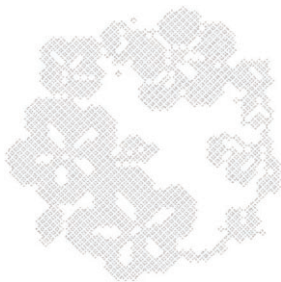

15 min	
1 (001)	

↓ 145.1 mm  
↔ 144.9 mm

No.9



29 min	
1 (001)	
2 (399)	
3 (534)	
4 (502)	
5 (070)	
6 (406)	
7 (070)	
8 (399)	
9 (206)	
10 (070)	
11 (406)	
12 (534)	
13 (502)	

↓ 128.2 mm  
↔ 139.2 mm

No.5



21 min	
1 (337)	8 (337)
2 (019)	9 (019)
3 (614)	10 (614)
4 (612)	11 (612)
5 (507)	12 (507)
6 (206)	13 (206)
7 (348)	14 (348)

↓ 85.8 mm ↔ 91.3 mm



**No.10** 12 min

1	■ (333)
2	■ (607)
3	■ (206)
4	■ (399)
5	■ (517)
6	■ (612)
7	■ (337)
8	■ (017)
9	■ (005)
↓	84.9 mm
↔	86.4 mm

**No.13** 36 min

1	■ (900)
2	■ (030)
↓	252.6 mm
↔	152.5 mm

Taishi: Ambition  
大志  
大志  
대지

**No.11** 44 min

1	■ (900)
2	■ (030)
↓	251.8 mm
↔	175.8 mm

Kizuna: Band  
絆  
絆  
반

**No.14** 25 min

1	■ (900)
2	■ (030)
↓	184.7 mm
↔	104.6 mm

Seiko: Success  
成功  
成功  
성공

**No.12** 19 min

1	■ (900)
2	■ (030)
↓	122.4 mm
↔	142.8 mm

Iwai: Celebration  
祝  
祝  
축

**No.15** 19 min

1	■ (900)
2	■ (030)
↓	178.0 mm
↔	93.2 mm

Sozo: Creation  
创造  
創造  
창조

Patterns No.11 – No.15, are designed by Taisen Okamoto.  
花樣编号为 No.11-No.15 是由岡本苔泉所设计。  
花樣 No.11 – No.15 由岡本苔泉設計。  
패턴 No.11 – No.15 은 Taisen Okamoto 가 디자인하였습니다.

◆ Brother “Exclusives” Quilt designs

◆ Brother “独家” 绗缝设计

◆ Brother 「專屬」被面設計

◆ 부라더 “전용” 킨트 디자인

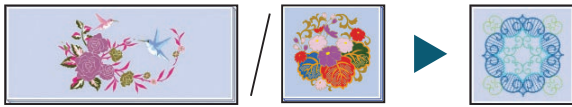

**No.1** **14 min**

1	(214)
2	(517)
3	(348)

↓ 169.4 mm  
↔ 176.2 mm

**No.4**

**13 min**

1	(509)	3	(323)
2	(005)	4	(209)

↓ 173.6 mm ↔ 174.0 mm

**No.7** **3 min**

1	(517)
2	(208)
3	(800)

↓ 123.9 mm  
↔ 59.4 mm

**No.8**

**10 min**

1	(005)	2	(800)	3	(614)
---	-------	---	-------	---	-------

↓ 98.7 mm ↔ 173.8 mm

**No.2** **3 min**

1	(333)
2	(348)

↓ 90.5 mm  
↔ 42.5 mm

**No.5** **3 min**

1	(323)
2	(509)

↓ 180.9 mm  
↔ 45.3 mm

**No.9**

**24 min**

1	(534)	3	(405)	5	(513)
2	(019)	4	(542)		

↓ 174.4 mm ↔ 174.4 mm

**No.3** **38 min**

1	(017)
2	(019)
3	(807)
4	(420)
5	(333)
6	(017)
7	(333)
8	(807)
9	(086)
10	(420)

↓ 273.0 mm  
↔ 137.7 mm

**No.6**

**10 min**

1	(800)	6	(900)
2	(900)	7	(800)
3	(800)	8	(900)
4	(900)	9	(800)
5	(800)		

↓ 140.1 mm ↔ 140.4 mm

**No.10**

**13 min**

1	(614)	2	(415)	3	(807)
---	-------	---	-------	---	-------

↓ 148.8 mm ↔ 147.9 mm

◆ Brother “Exclusives” New-Technique designs

◆ Brother “独家” 新技术设计

◆ Brother 「專屬」新技術設計

◆ 부라더 “전용” 뉴 테크닉 디자인



No.5

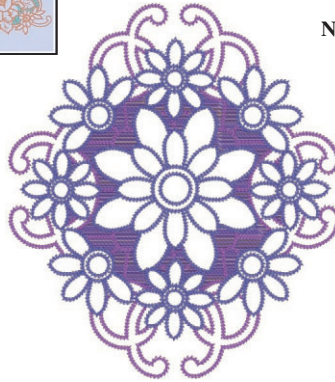

103 min		
1	(614)	2 (612) 3 (607)
↓ 197.5 mm ↔ 175.1 mm		



No.9



9 min	
1	(019)
↓	17.3 mm
↔	96.0 mm

No.1



12 min	
1	(070)
2	(348)
↓	78.2 mm
↔	120.8 mm



No.10



17 min	
1	(800)
↓	33.2 mm
↔	114.5 mm

No.2



12 min	
1	(070)
2	(348)
↓	64.4 mm
↔	145.3 mm



No.6



21 min	
1	(010)
↓	70.4 mm
↔	78.8 mm



No.11



11 min	
1	(208)
↓	32.9 mm
↔	93.6 mm

No.3



21 min	
1	(328)
2	(337)
3	(519)
4	(515)
5	(001)
6	(005)
↓	70.5 mm
↔	107.2 mm

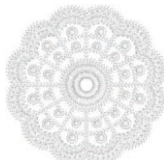

No.7



48 min	
1	(001)
↓	83.7 mm
↔	83.5 mm

No.8



40 min	
1	(030)
2	(515)
3	(208)
↓	85.9 mm
↔	98.9 mm



No.12



39 min	
1	(328)
2	(399)
↓	107.4 mm
↔	112.6 mm

No.4



49 min	
1	(808)
2	(812)
3	(513)
↓	226.6 mm
↔	109.8 mm

 Embroidering on water-soluble sheets without any fabric

绣制在无布料的水溶性衬纸上

使用水溶性紙刺繡，而不使用任何布料

천 없이 수용성 시트에 자수

Refer to “3D combination motifs” on page 53 for detailed instruction.

详细说明请参见第 53 页上的 “3D 组合图案”。

關於詳細說明，請參閱第 53 頁「3D 組合鏤空圖案」。

자세한 설명은 53 페이지 “3D 조합 모티프”를 참조하세요.

Embroidery Pattern Color Change Table

绣花花样颜色变更表  
刺繡花樣顏色轉換表  
자수 패턴 색 변경 표

**No.13** **23 min**



1	(406)
2	(070)
3	(399)
↕	124.6 mm
↔	83.4 mm

**No.14** **14 min**



1	(070)
2	(399)
↕	98.9 mm
↔	39.3 mm

**No.15** **60 min**



1	(019)
2	(810)
3	(534)
4	(007)
5	(019)
6	(079)
7	(007)
↕	200.4 mm
↔	161.7 mm

Embroidering on water-soluble sheets without any fabric

绣制在无布料的水溶性衬纸上

使用水溶性紙刺繡，而不使用任何布料

천 없이 수용성 시트에 자수

Recommended for embroidering on thin fabric such as organza

建议绣制在如纱等薄布料上。

適用於刺繡薄布料（如薄紗）

오간자처럼 얇은 천에 자수 놓는 것을 권장

Refer to "3D combination motifs" on page 53 for detailed instruction.

详细说明请参见第 53 页上的 "3D 组合图案"。

關於詳細說明，請參閱第 53 頁「3D 組合鏤空圖案」。

자세한 설명은 53 페이지 "3D 조합 모티프"를 참조하세요.

◆ Brother "Exclusives" Zündt designs

◆ Brother "独家" Zündt 设计

◆ Brother 「專屬」Zündt 設計

◆ 부라더 "전용" Zündt 디자인

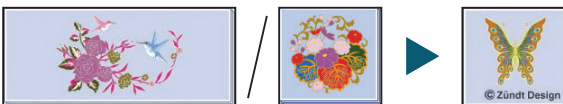

**No.1** **57 min**



1	(214)
2	(206)
3	(126)
4	(800)
5	(206)
6	(126)
7	(800)
8	(086)
9	(214)
↕	250.8 mm
↔	170.8 mm

**No.2** **20 min**



1	(206)	6	(206)	
2	(126)	7	(126)	
3	(800)	8	(800)	
4	(086)	9	(086)	
5	(214)	10	(214)	
↕	180.0 mm ↔ 84.8 mm			

**No.3** **11 min**



1	(214)
↕	258.4 mm
↔	175.6 mm

**No.4** **4 min**



1	(214)
↕	175.8 mm
↔	83.8 mm



**No.5** **36 min**

1	(085)
2	(010)
3	(027)
4	(620)
5	(010)
6	(027)

↓ 175.6 mm  
↔ 141.8 mm



**No.6** **26 min**

1	(085)
2	(620)
3	(513)
4	(027)

↓ 184.6 mm  
↔ 142.0 mm



**No.7** **5 min**

1	(620)
---	-------

↓ 116.4 mm  
↔ 129.0 mm

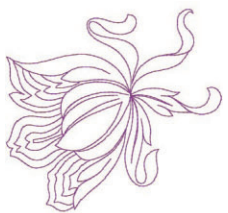

**No.8** **2 min**

1	(620)
---	-------

↓ 106.8 mm  
↔ 113.4 mm



**No.9** **57 min**

1	(070)	5	(126)
2	(328)	6	(010)
3	(513)	7	(323)
4	(612)		

↓ 175.0 mm ↔ 157.4 mm



**No.10**

**32 min**

1	(085)	6	(209)
2	(614)	7	(810)
3	(502)	8	(085)
4	(810)	9	(214)
5	(206)	10	(323)

↓ 214.0 mm ↔ 95.6 mm



**No.11** **17 min**

1	(085)
2	(614)
3	(502)
4	(810)
5	(206)
6	(209)
7	(810)
8	(085)
9	(214)

↓ 99.4 mm  
↔ 97.8 mm



**No.12** **3 min**

1	(502)
2	(810)
3	(085)
4	(614)

↓ 29.0 mm  
↔ 66.2 mm



**No.13**

**45 min**

1	(085)	6	(010)
2	(079)	7	(027)
3	(348)	8	(206)
4	(085)	9	(214)
5	(515)		

↓ 163.8 mm ↔ 163.8 mm



**No.14** **49 min**

1	(085)
2	(079)
3	(348)
4	(085)
5	(515)
6	(010)
7	(027)
8	(206)
9	(214)

↓ 276.6 mm  
↔ 90.8 mm



**No.15** **20 min**

1	(085)
2	(079)
3	(348)
4	(010)
5	(027)
6	(206)
7	(214)

↓ 100.4 mm  
↔ 99.8 mm

Patterns No.1 - No.15, are designed by Zündt Design, Ltd.  
 花樣编号为 NO.1-NO.15 是由 Zündt Design, Ltd. 所设计。  
 花樣 No.1 - No.15 由 Zündt Design, Ltd. 設計。  
 패턴 No.1 - No.15 는 Zündt Design, Ltd 가 디자인하였습니다.

◆ Floral alphabet patterns

◆ 花纹字母花样

◆ 花飾字母花樣

◆ 꽃 알파벳 패턴



No.1

24 min	
1	(328)
2	(804)
3	(612)
4	(079)
5	(807)
6	(513)
7	(502)
↓	145.1 mm
↔	125.7 mm



No.6

22 min	
1	(328)
2	(804)
3	(612)
4	(079)
5	(807)
6	(513)
7	(502)
↓	142.8 mm
↔	101.8 mm



No.11

27 min	
1	(328)
2	(804)
3	(612)
4	(079)
5	(807)
6	(513)
7	(502)
↓	142.0 mm
↔	119.6 mm



No.2

27 min	
1	(328)
2	(804)
3	(612)
4	(079)
5	(807)
6	(513)
7	(502)
↓	140.9 mm
↔	108.1 mm



No.7

26 min	
1	(328)
2	(804)
3	(612)
4	(079)
5	(807)
6	(513)
7	(502)
↓	141.6 mm
↔	117.3 mm



No.12

20 min	
1	(328)
2	(804)
3	(612)
4	(079)
5	(807)
6	(513)
7	(502)
↓	144.9 mm
↔	107.0 mm



No.3

22 min	
1	(328)
2	(804)
3	(612)
4	(079)
5	(807)
6	(513)
7	(502)
↓	141.8 mm
↔	114.5 mm



No.8

30 min	
1	(328)
2	(804)
3	(612)
4	(079)
5	(807)
6	(513)
7	(502)
↓	141.7 mm
↔	121.6 mm



No.13

32 min	
1	(328)
2	(804)
3	(612)
4	(079)
5	(807)
6	(513)
7	(502)
↓	146.5 mm
↔	124.6 mm



No.4

26 min	
1	(328)
2	(804)
3	(612)
4	(079)
5	(807)
6	(513)
7	(502)
↓	141.2 mm
↔	108.3 mm



No.9

19 min	
1	(328)
2	(804)
3	(612)
4	(079)
5	(807)
6	(513)
7	(502)
↓	145.8 mm
↔	49.7 mm



No.14

27 min	
1	(328)
2	(804)
3	(612)
4	(079)
5	(807)
6	(513)
7	(502)
↓	147.0 mm
↔	116.8 mm



No.5

25 min	
1	(328)
2	(804)
3	(612)
4	(079)
5	(807)
6	(513)
7	(502)
↓	144.3 mm
↔	102.5 mm



No.10

20 min	
1	(328)
2	(804)
3	(612)
4	(079)
5	(807)
6	(513)
7	(502)
↓	144.5 mm
↔	82.3 mm



No.15

25 min	
1	(328)
2	(804)
3	(612)
4	(079)
5	(807)
6	(513)
7	(502)
↓	146.3 mm
↔	115.3 mm



No.16

23 min

1	(328)
2	(804)
3	(612)
4	(079)
5	(807)
6	(513)
7	(502)
↓	143.4 mm
↔	99.6 mm



No.20

24 min

1	(328)
2	(804)
3	(612)
4	(079)
5	(807)
6	(513)
7	(502)
↓	144.5 mm
↔	118.4 mm



No.24

25 min

1	(328)
2	(804)
3	(612)
4	(079)
5	(807)
6	(513)
7	(502)
↓	142.3 mm
↔	115.9 mm



No.17

27 min

1	(328)
2	(804)
3	(612)
4	(079)
5	(807)
6	(513)
7	(502)
↓	142.7 mm
↔	118.2 mm



No.21

24 min

1	(328)
2	(804)
3	(612)
4	(079)
5	(807)
6	(513)
7	(502)
↓	144.6 mm
↔	118.5 mm



No.25

22 min

1	(328)
2	(804)
3	(612)
4	(079)
5	(807)
6	(513)
7	(502)
↓	142.8 mm
↔	116.3 mm



No.18

28 min

1	(328)
2	(804)
3	(612)
4	(079)
5	(807)
6	(513)
7	(502)
↓	143.4 mm
↔	112.5 mm



No.22

24 min

1	(328)
2	(804)
3	(612)
4	(079)
5	(807)
6	(513)
7	(502)
↓	145.5 mm
↔	121.5 mm



No.26

26 min

1	(328)
2	(804)
3	(612)
4	(079)
5	(807)
6	(513)
7	(502)
↓	142.8 mm
↔	92.9 mm



No.19

28 min

1	(328)
2	(804)
3	(612)
4	(079)
5	(807)
6	(513)
7	(502)
↓	144.1 mm
↔	99.4 mm



No.23

32 min

1	(328)
2	(804)
3	(612)
4	(079)
5	(807)
6	(513)
7	(502)
↓	146.2 mm
↔	124.8 mm



No.27

4 min

1	(328)
2	(079)
3	(807)
4	(513)
5	(502)
↓	51.9 mm
↔	45.9 mm



No.29

4 min

1	(328)
2	(079)
3	(807)
4	(513)
5	(502)
↓	52.2 mm
↔	41.1 mm



No.31

4 min

1	(328)
2	(079)
3	(807)
4	(513)
5	(502)
↓	53.1 mm
↔	37.3 mm



No.33

4 min

1	(328)
2	(079)
3	(807)
4	(513)
5	(502)
↓	51.9 mm
↔	42.7 mm



No.35

4 min

1	(328)
2	(079)
3	(807)
4	(513)
5	(502)
↓	53.9 mm
↔	23.8 mm



No.28

4 min

1	(328)
2	(079)
3	(807)
4	(513)
5	(502)
↓	51.7 mm
↔	39.6 mm



No.30

4 min

1	(328)
2	(079)
3	(807)
4	(513)
5	(502)
↓	51.9 mm
↔	39.3 mm



No.32

4 min

1	(328)
2	(079)
3	(807)
4	(513)
5	(502)
↓	52.1 mm
↔	36.6 mm



No.34

5 min

1	(328)
2	(079)
3	(807)
4	(513)
5	(502)
↓	52.2 mm
↔	44.3 mm



No.36

3 min

1	(328)
2	(079)
3	(807)
4	(513)
5	(502)
↓	52.6 mm
↔	30.1 mm



Embroidery Pattern Color Change Table

绣花花样颜色变更表

刺繡花樣顏色轉換表

자수 패턴 색 변경 표

**No.37**

5 min	
1	(328)
2	(079)
3	(807)
4	(513)
5	(502)
↓	52.4 mm
↔	43.4 mm

**No.41**

4 min	
1	(328)
2	(079)
3	(807)
4	(513)
5	(502)
↓	52.8 mm
↔	42.6 mm

**No.45**

4 min	
1	(328)
2	(079)
3	(807)
4	(513)
5	(502)
↓	52.6 mm
↔	35.0 mm

**No.49**

5 min	
1	(328)
2	(079)
3	(807)
4	(513)
5	(502)
↓	53.3 mm
↔	46.5 mm

**No.38**

3 min	
1	(328)
2	(079)
3	(807)
4	(513)
5	(502)
↓	52.5 mm
↔	38.9 mm

**No.42**

4 min	
1	(328)
2	(079)
3	(807)
4	(513)
5	(502)
↓	52.1 mm
↔	36.9 mm

**No.46**

4 min	
1	(328)
2	(079)
3	(807)
4	(513)
5	(502)
↓	53.0 mm
↔	42.0 mm

**No.50**

4 min	
1	(328)
2	(079)
3	(807)
4	(513)
5	(502)
↓	51.7 mm
↔	42.0 mm

**No.39**

6 min	
1	(328)
2	(079)
3	(807)
4	(513)
5	(502)
↓	53.3 mm
↔	46.4 mm

**No.43**

4 min	
1	(328)
2	(079)
3	(807)
4	(513)
5	(502)
↓	52.6 mm
↔	43.3 mm

**No.47**

4 min	
1	(328)
2	(079)
3	(807)
4	(513)
5	(502)
↓	52.5 mm
↔	42.8 mm

**No.51**

4 min	
1	(328)
2	(079)
3	(807)
4	(513)
5	(502)
↓	53.8 mm
↔	42.2 mm

**No.40**

5 min	
1	(328)
2	(079)
3	(807)
4	(513)
5	(502)
↓	52.9 mm
↔	43.1 mm

**No.44**

4 min	
1	(328)
2	(079)
3	(807)
4	(513)
5	(502)
↓	52.3 mm
↔	40.7 mm

**No.48**

4 min	
1	(328)
2	(079)
3	(807)
4	(513)
5	(502)
↓	52.8 mm
↔	43.9 mm

**No.52**

4 min	
1	(328)
2	(079)
3	(807)
4	(513)
5	(502)
↓	52.4 mm
↔	33.4 mm

**No.53**

2 min	
1	(804)
2	(612)
3	(079)
4	(807)
5	(513)
6	(502)
↓	34.4 mm
↔	22.7 mm

**No.55**

4 min					
1	(804)	3	(079)	5	(513)
2	(612)	4	(807)	6	(502)
↓ 39.3 mm ↔ 75.4 mm					

**No.57**

7 min														
1	(804)	7	(804)	13	(079)									
2	(612)	8	(612)	14	(807)									
3	(079)	9	(079)	15	(513)									
4	(807)	10	(807)	16	(502)									
5	(513)	11	(513)											
6	(502)	12	(502)											
↓ 27.9 mm ↔ 121.9 mm														

**No.54**

2 min	
1	(079)
2	(807)
3	(513)
4	(502)
↓	39.8 mm
↔	25.6 mm

**No.56**

7 min											
1	(804)	5	(513)	9	(079)						
2	(612)	6	(502)	10	(807)						
3	(079)	7	(804)	11	(513)						
4	(807)	8	(612)	12	(502)						
↓ 23.4 mm ↔ 123.7 mm											



No. 58

13 min		
1 (079)	7 (513)	13 (079)
2 (807)	8 (502)	14 (807)
3 (513)	9 (079)	15 (513)
4 (502)	10 (807)	16 (502)
5 (079)	11 (513)	
6 (807)	12 (502)	
⇅ 103.6 mm ⇆ 94.9 mm		



No.60

5 min	
1 (513)	
2 (807)	
3 (513)	
4 (807)	
⇅ 106.7 mm	
⇆ 93.4 mm	



No.63

1 min	
1 (513)	
⇅ 147.2 mm	
⇆ 61.8 mm	



No.59

28 min		
1 (079)	17 (513)	33 (804)
2 (807)	18 (502)	34 (612)
3 (804)	19 (079)	35 (513)
4 (612)	20 (807)	36 (502)
5 (513)	21 (804)	37 (079)
6 (502)	22 (612)	38 (807)
7 (079)	23 (513)	39 (804)
8 (807)	24 (502)	40 (612)
9 (804)	25 (079)	41 (513)
10 (612)	26 (807)	42 (502)
11 (513)	27 (804)	43 (079)
12 (502)	28 (612)	44 (807)
13 (079)	29 (513)	45 (804)
14 (807)	30 (502)	46 (612)
15 (804)	31 (079)	47 (513)
16 (612)	32 (807)	48 (502)
⇅ 218.4 mm ⇆ 175.7 mm		



No.61

4 min	
1 (513)	
2 (807)	
3 (513)	
4 (807)	
⇅ 42.6 mm	
⇆ 142.0 mm	



No.64

8 min		
1 (804)	9 (079)	17 (513)
2 (612)	10 (807)	18 (502)
3 (079)	11 (513)	19 (804)
4 (807)	12 (502)	20 (612)
5 (513)	13 (804)	21 (079)
6 (502)	14 (612)	22 (807)
7 (804)	15 (079)	23 (513)
8 (612)	16 (807)	24 (502)
⇅ 73.3 mm ⇆ 72.8 mm		



No.62

15 min		
1 (513)	4 (807)	7 (513)
2 (807)	5 (513)	8 (807)
3 (513)	6 (807)	
⇅ 216.6 mm ⇆ 175.7 mm		

◆ Patterns for bobbin work

Bobbin work can only be performed in the "Embroidery Mode".

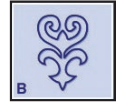

◆ 为梭芯工作设计的花样

梭芯仅在“绣花模式”中进行工作。

◆ 底線刺繡的花樣

只有在「刺繡模式」下才能進行底線刺繡。

◆ 실토리 작업용 패턴

실토리 작업은 “자수 모드” 에서만 수행할 수 있습니다.

**Note :** Embroidery patterns for bobbin work are reversed when they have been sewn.

**注意 :** 将反转已绣制的为梭芯工作而设计的绣花花样。

**註釋 :** 已縫紉底線刺繡的刺繡花樣時，花樣會顛倒過來。

**참고 :** 실토리 작업용 자수 패턴은 재봉했을 때에 반전됩니다.

All of the designs shown in the Bobbin work area are pictured in the machine mirrored or flipped.

梭芯工作区域中的所有设计在机器中被镜像或翻转显示。

底線刺繡區所示的所有設計都是鏡像或翻轉圖像。

실토리 작업 영역의 모든 디자인은 기기에서 좌우 또는 상하가 바뀌어 나타납니다.

**No.1**

<b>3 min</b>
1 (030)
↓ 175.1 mm
↔ 97.0 mm
1.5 m (1.7 yd) (0.9 m + 0.6 m)

Time is based on the recommended 100spm.  
 时间是以推荐绣制速度 100spm 为基础。  
 時間是以建議速度 100spm 測得。  
 시간은 권장 100spm 을 기준으로 합니다.

Total length of thread needed to sew the pattern (to sew the pattern + to tie ends)  
 要绣制花样的线总长 (要绣制花样的长度 + 要打结的长度)  
 縫紉該花樣時所需線的總長 (縫紉花樣 + 綁緊線頭)  
 패턴 재봉에 필요한 실의 총길이 (패턴 재봉 + 끝 매듭)

**No.2**

<b>4 min</b>
1 (509)
↓ 123.6 mm
↔ 127.0 mm
1.6 m (1.8 yd) (1.0 m + 0.6 m)

**No.3**

<b>10 min</b>
1 (405)
↓ 164.9 mm
↔ 125.0 mm
2.8 m (3.1 yd) (2.2 m + 0.6 m)

**No.4**

<b>6 min</b>
1 (030)
↓ 196.0 mm
↔ 98.4 mm
2.3 m (2.6 yd) (1.7 m + 0.6 m)

Refer to the operation manual for the sewing machine for details on how to embroider bobbin work patterns.

有关如何绣制梭芯工作花样的详细信息，请参见绣花机的使用说明书。

關於如何進行底線刺繡花樣的詳細資訊，請參閱刺繡縫紉機的使用說明書。

실토리 작업 패턴 자수 방법에 관한 자세한 내용은 재봉기 작동 설명서를 참조하세요.

Embroidery Pattern Color Change Table

绣花花样颜色变更表

刺繡花樣顏色轉換表

자수 패턴 색 변경 표



No.5



<b>5 min</b>	
1	(405)
↕	174.8 mm
↔	104.4 mm
 1.8 m (2.0 yd) (1.2 m + 0.6 m)	

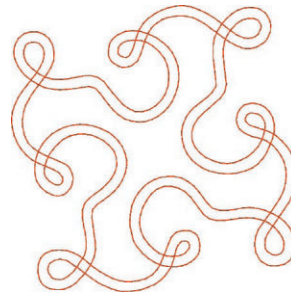

No.10



<b>7 min</b>	
1	(030)
↕	126.2 mm
↔	125.9 mm
 2.4 m (2.7 yd) (1.8 m + 0.6 m)	

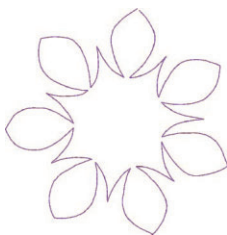

No.6

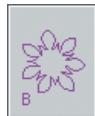

<b>4 min</b>	
1	(620)
↕	135.5 mm
↔	133.3 mm
 1.6 m (1.8 yd) (1.0 m + 0.6 m)	

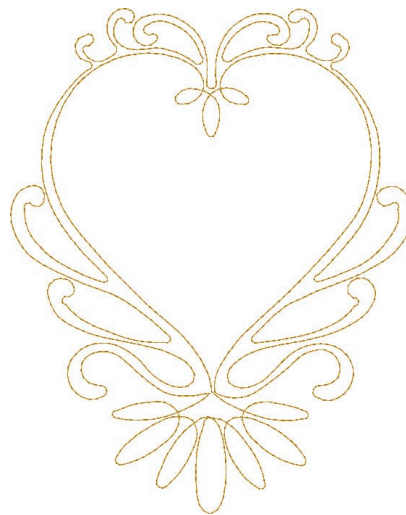

No.11



<b>10 min</b>	
1	(328)
↕	223.5 mm
↔	177.3 mm
 3.5 m (3.9 yd) (2.9 m + 0.6 m)	

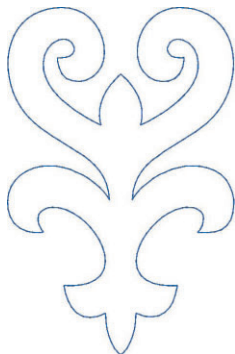

No.7

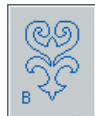

<b>3 min</b>	
1	(405)
↕	153.9 mm
↔	100.0 mm
 1.6 m (1.8 yd) (1.0 m + 0.6 m)	



No.8



<b>2 min</b>	
1	(509)
↕	63.3 mm
↔	75.1 mm
 1.1 m (1.2 yd) (0.5 m + 0.6 m)	



No.12



<b>8 min</b>	
1	(542)
↕	123.5 mm
↔	135.5 mm
 2.7 m (3.0 yd) (2.1 m + 0.6 m)	

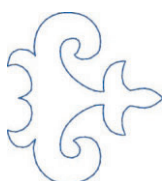

No.9



<b>2 min</b>	
1	(405)
↕	75.0 mm
↔	67.7 mm
 1.0 m (1.1 yd) (0.4 m + 0.6 m)	



No.13



<b>6 min</b>	
1	(209)
↕	81.5 mm
↔	118.3 mm
 2.2 m (2.4 yd) (1.6 m + 0.6 m)	

# Examples of Combinations

## 花样组合示例

### 組合範例

### 조합 예

Combine various embroidery patterns, as shown below, to enhance your embroidering enjoyment.

如下所示， 組合不同的绣花花样以增加您的绣制乐趣。

如下所示組合各種刺繡花樣， 以增添您的刺繡樂趣。

아래처럼 다양한 자수 패턴을 조합하여 더 큰 자수의 재미를 느껴세요.

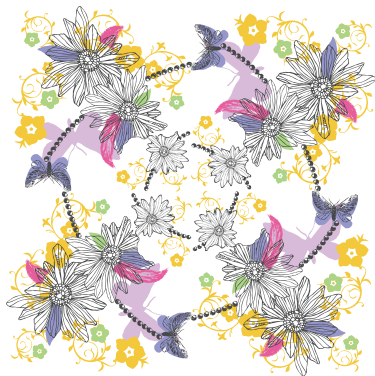
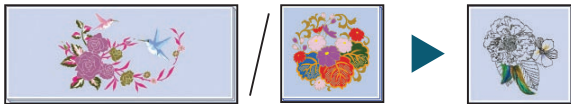

No.3 x 4



No.9 x 2

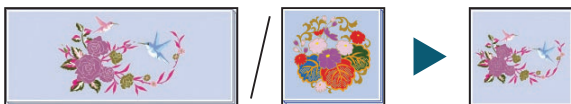

No.1 + No.2



No.4 x 2

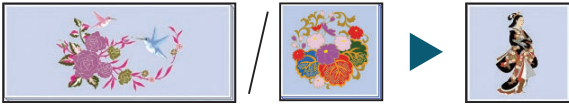

No.3 + No.4



No.8 × 2

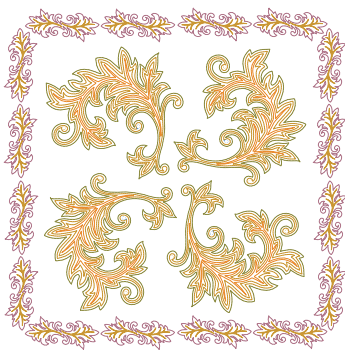
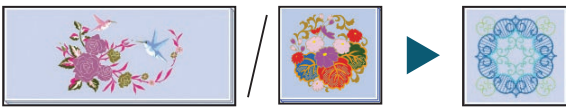

No.1 × 4 + No.2 × 16

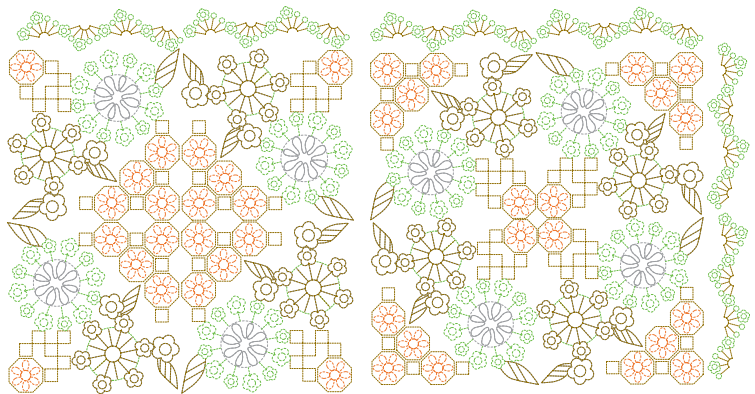

No.4 × 8 + No.5 × 6

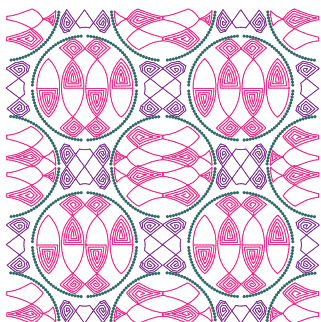

No.10 × 4

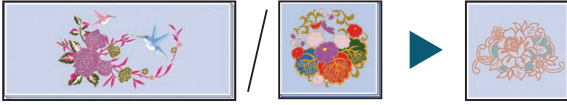

### ◆ 3D combination motifs

### ◆ 3D 组合图案

### ◆ 3D 組合鏤空圖案

### ◆ 3D 조합 모티프

#### How to make 3D combination motifs

1. Use the same color of thread in the bobbin and on top for the designs.
2. Embroider individual shapes. When sections are completed they are joined to make dimensional shapes. Use a thread or narrow ribbon of a complimentary color to join them.

 When embroidering on organza, tulle or similar fabrics, hoop together a single layer of water-soluble stabilizer with the fabric to be embroidered. When the embroidery process is complete, remove from the hoop and thoroughly rinse embroidered piece in warm water. Dry until the piece is slightly damp, shape by hand or with cool iron. When dry, trim edges.

 The following are things you should be aware of when using water-soluble sheets without any fabric. When embroidering these designs, please use three layers of water-soluble sheets. Remember to check that you have enough upper thread and lower thread for the design. If the thread breaks during embroidery, back up at least 10 stitches before starting again. If your embroidery machine has a speed reduction feature, select the lowest speed. When dissolving the water-soluble sheet, cut off the unnecessary portions and wash the embroidered piece in warm water until it no longer feels slippery. After the final rinse, dry the embroidery motif until slightly damp, shape by hand or with a cool iron, allow to dry completely.

#### 如何制作 3D 组合图案

1. 使用与梭芯中以及设计顶部相同的线色。
2. 绣制单个形状。当各个部分完成时，将其组合成立体的形状。使用与绣制线颜色互补的线或较窄丝带连接各部分。

 当绣制在纱、薄纱或类似的布料上时，将一片水溶性衬纸与要绣制的布料箍在一起。当绣制过程结束时，从箍上取下水溶性衬纸并在温水中彻底浸洗绣花布。将其晾干至略微有些潮湿，然后用手或者冷熨斗塑形。干燥后，修剪边缘。

 使用水溶性衬纸而没有任何布料时，您应该注意以下内容。绣制这些设计时，请使用三层水溶性衬纸。请记住要检查绣制此设计是否有足够的面线和底线。如果在绣制时发生断线，再次开始前请倒退至少 10 针。如果您的绣花机有减速功能，请选择最低的速度。当溶解水溶性衬纸时，剪断不必要的部分并且在温水中洗绣花布直到感觉不滑即可。冲洗之后，将绣花图案晾干至略微有些潮湿，用手或者使用冷却熨斗塑形并使其完全干燥。

#### 如何製作 3D 組合鏤空圖案

1. 底線和設計上面使用相同的繡線顏色。
2. 刺繡單個形狀。部分完成時，將其拼接成立體形狀。使用一條互補色的繡線或窄幅飄帶進行拼接。

 刺繡薄紗、綉網或類似布料時，將一層水溶性襯料與要刺繡的布料箍在一起。刺繡流程完成時，取下繡花框，然後用溫水徹底沖洗刺繡件。將刺繡件晾乾到微濕，用手或低溫熨斗塑形。全乾後再修邊。

 使用水溶性紙，而不使用任何布料時，須注意下列事項。刺繡這些設計時，請使用三層水溶性紙。務必確認您有足夠的上線和底線以供設計刺繡。如果在刺繡時斷線，重新開始前請先倒退 10 針。如果本機有減速功能，請選擇最低速。溶解水溶性紙時，修剪不需要的部分，然後以溫水沖洗刺繡件，直到不再感覺滑溜。最後一次沖洗後，將刺繡鏤空圖案晾乾到微濕，用手或低溫熨斗塑形，使其完全乾燥。

#### 3D 조합 모티프 만드는 방법

1. 같은 색의 실을 디자인의 밑실과 뒷실로 사용하세요.
2. 개별 모양을 자수 놓으세요. 부분들이 완성되면 입체 모양으로 연결하세요. 보색의 실이나 폭이 좁은 리본을 사용하여 연결하세요.

 오간자, 툴 또는 유사한 천에 자수 놓을 때에는 한 겹의 수용성 보강재를 자수 놓을 천과 함께 끼우세요. 자수를 마치면 틀을 제거하고 자수 놓은 천을 따뜻한 물에 잘 행구세요. 천을 약간 축축할 때까지 말리고 손이나 찬 다리미로 모양을 잡으세요. 마르면 가장자리를 정돈하세요.

 다음은 천 없이 수용성 시트를 사용할 때에 알아야 할 사항입니다. 이 디자인을 자수 놓을 때에는 세 겹의 수용성 시트를 사용하세요. 디자인의 뒷실과 밑실이 충분한지 반드시 확인하세요. 자수 중에 실이 끊어지면 다시 시작하기 전에 적어도 10 땀을 보강하세요. 자수기에 감속 기능이 있으면 최저 속도를 선택하세요. 수용성 시트를 녹일 때에는 불필요한 부분을 자르고 자수 놓은 조각을 미끌거리지 않을 때까지 따뜻한 물에 씻으세요. 마지막으로 행구 후에 자수 모티프를 약간 축축할 때까지 말리고 손이나 찬 다리미로 모양을 잡고 완전히 말리세요.

No.6 x 6 

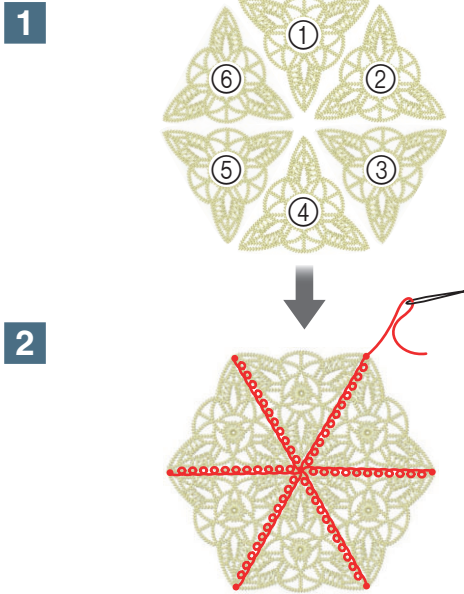

No.12 

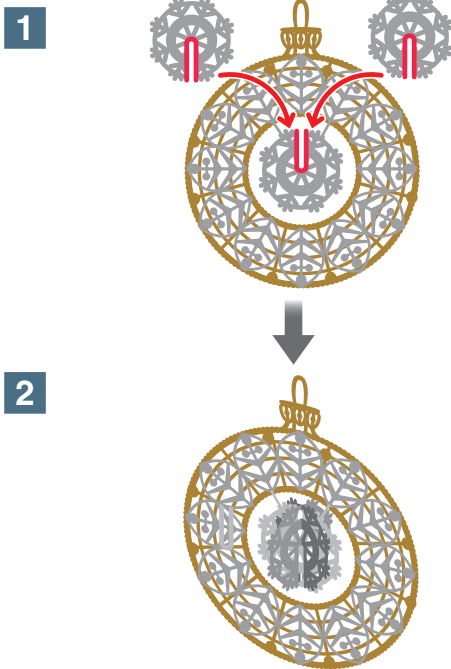

No.13 x 3 

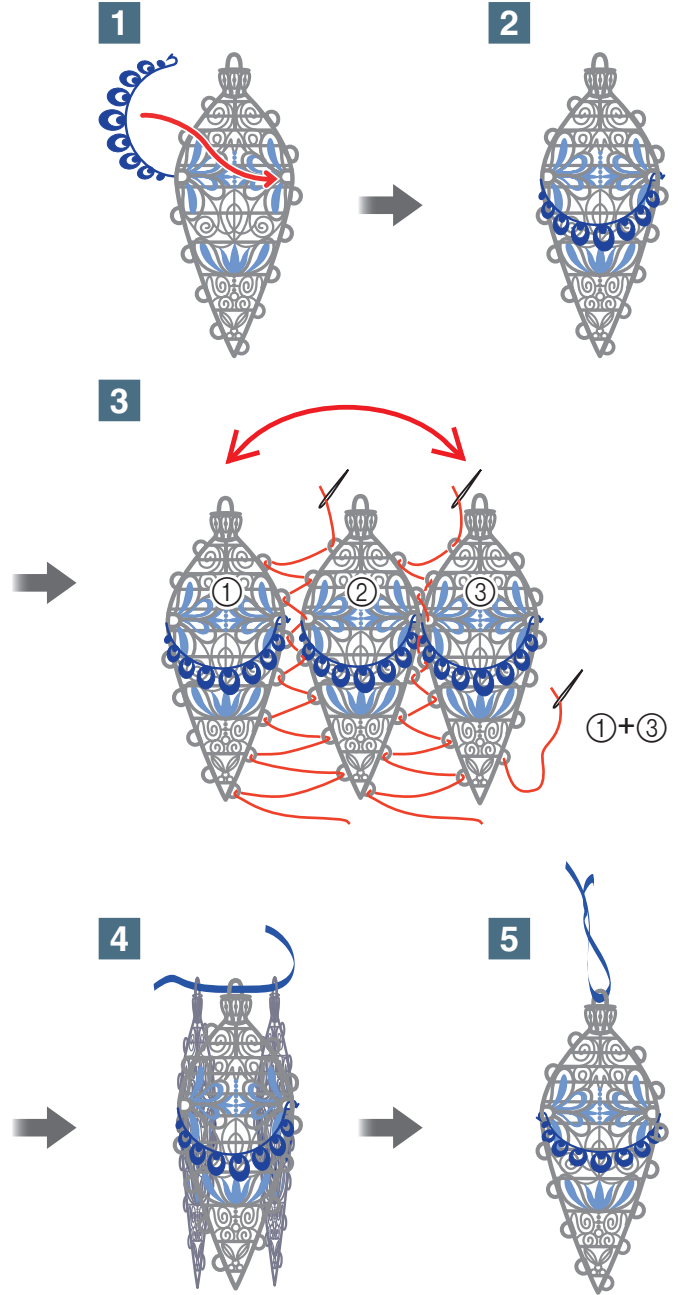



No.14 

**A**



No.14 × 9 

**B**

**1**

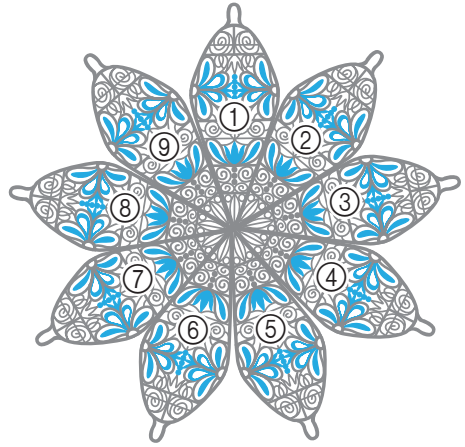

**2**

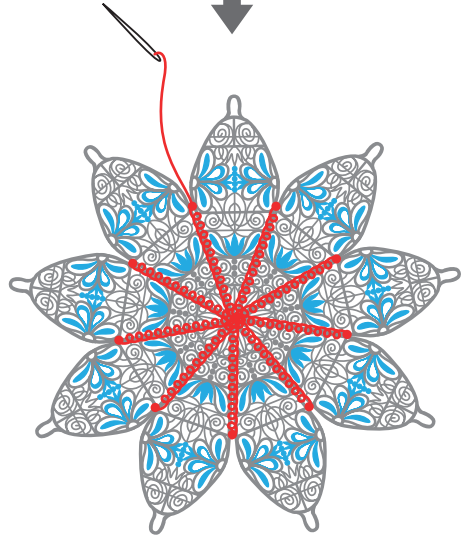

No.15 

**1**

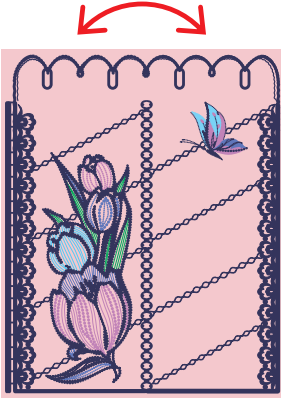

**2**

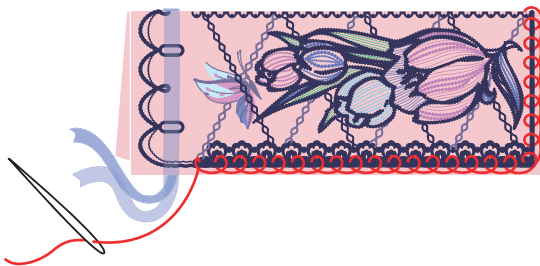

**3**

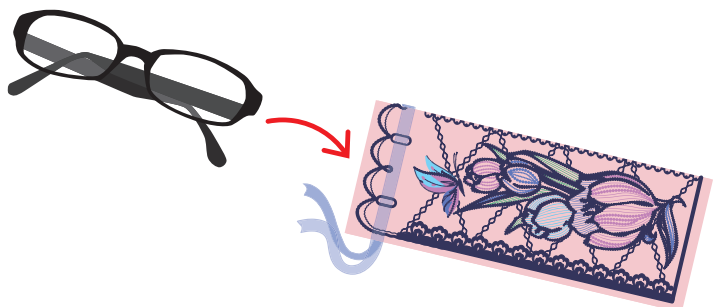

# Color Thread Conversion Chart

## 绣花线颜色转换表

## 繡線顏色轉換表

## 색실 변환 차트

	Color Name / 颜色名称 / 顏色名稱 / 색 이름	Embroidery	Country	Madeira Polyneon	Madeira Rayon	Sulky	R.A. Polyester
1	Black / 黑色 / 黑 / 검정	 900	 100	1800	1000	1005	5596
2	White / 白色 / 白 / 하양	 001	 000	1801	1002	1001	5597
3	Red / 红色 / 紅 / 빨강	 800	 149	1637	1037	1037	5678
4	Pink / 粉红 / 粉 / 분홍	 085	 155	1921	1108	1224	5523
5	Deep Rose / 深玫瑰色 / 深玫瑰 / 진한 장미색	 086	 024	1721	1117	1154	9168
6	Flesh Pink / 肉红色 / 淡粉 / 살분홍	 124	 152	1915	1015	1064	5677
7	Dark Fuchsia / 深桃红 / 深桃紅 / 어두운 푸크시아색	 107	 126	1984	1383	1533	5804
8	Vermillion / 朱红 / 朱紅 / 주색	 030	 148	1779	1179	1184	9023
9	Carmine / 洋红色 / 胭脂紅 / 카민	 807	 158	1986	1081	1511	5561
10	Royal Purple / 淡紫色 / 皇家紫 / 로열퍼플	 869	 636	1788	1188	1192	5681
11	Magenta / 洋红色 / 紅紫 / 마젠타	 620	 625	1710	1319	1191	5592
12	Salmon Pink / 橙红色 / 橙紅 / 새면핑크	 079	 122	1816	1317	1225	5773
13	Amber Red / 琥珀红 / 琥珀紅 / 앰버레드	 333	 212	1942	1341	1119	5591
14	Lemon Yellow / 柠檬黄 / 檸檬黃 / 레몬옐로	 202	 342	1623	1023	1067	5625
15	Yellow / 黄色 / 黃 / 노랑	 205	 043	1980	1068	1187	5860
16	Harvest Gold / 丰收金 / 金 / 하비스트골드	 206	 334	1971	1024	1124	5770
17	Orange / 橘色 / 橘 / 주황	 208	 335	1951	1137	1024	5694
18	Pumpkin / 桔黄色 / 南瓜色 / 호박색 (채소)	 126	 322	1952	1155	1065	5630
19	Tangerine / 橘红色 / 蜜桔橘 / 귤색	 209	 336	1965	1078	1078	5518
20	Cream Brown / 奶油棕 / 奶油棕 / 크림브라운	 010	 331	1866	1022	1061	5761
21	Cream Yellow / 奶油黄 / 奶油黃 / 크림옐로	 812	 370	1861	1349	1135	5564
22	Khaki / 土黄色 / 卡其色 / 카키색	 348	 242	1939	1255	1055	5636
23	Deep Gold / 暗金 / 深金 / 진한 금색	 214	 354	1772	1172	1025	5770
24	Brass / 黄铜色 / 黃銅色 / 황동색	 328	 404	1791	1192	1159	9109
25	Linen / 亚麻色 / 亞麻色 / 리넨색	 307	 025	1682	1149	1082	5635
26	Dark Brown / 暗棕色 / 深棕 / 어두운 갈색	 058	 717	1859	1130	1129	5637
27	Reddish Brown / 红褐色 / 紅棕 / 적갈색	 337	 264	1753	1253	1021	5781
28	Clay Brown / 土褐色 / 土棕褐 / 클레이브라운	 339	 224	1621	1021	1158	5590
29	Beige / 米黄色 / 米色 / 베이지색	 843	 012	1738	1138	1127	5598
30	Warm Gray / 暖灰色 / 暖灰 / 워그레이	 399	 706	1860	1085	1218	9126
31	Russet Brown / 赤褐色 / 黃褐棕 / 팔색	 330	 414	1726	1194	1126	5702
32	Light Brown / 浅棕色 / 淺棕 / 밝은 갈색	 323	 255	1729	1056	1128	5789
33	Seacrest / 西克雷斯特 / 青瓷色 / 청자색 (도기)	 542	 505	1647	1219	1077	5578
34	Mint Green / 薄荷绿 / 薄荷綠 / 민트그린	 502	 461	1702	1302	1047	5511
35	Leaf Green / 叶绿 / 黃 / 리프그린	 509	 463	1749	1050	1510	5514
36	Olive Green / 橄欖绿 / 橄欖綠 / 올리브그린	 519	 476	1904	1396	1174	5502
37	Dark Olive / 暗橄欖绿 / 暗橄欖綠 / 어두운 올리브색	 517	 473	1769	1156	1156	9122
38	Teal Green / 蓝绿色 / 深青綠 / 틸그린	 534	 483	1879	1298	1503	5751
39	Emerald Green / 翡翠绿 / 鮮綠 / 에메랄드그린	 507	 485	1750	1250	1079	5508



English  
Chinese-simp  
Chinese-trad  
Korean

882-C40/C42/C50  
Printed in Taiwan



XF5653-001