

Quick reference guide

快速操作指南

快速導覽手冊

빠른 참조 안내서

Refer to the operation manual for detailed instruction.

Also, there are differences in the keys and screens depending on the display language. In this guide, English screens are used for basic explanations.

有关详细说明，请参见使用说明书。

另外，按键和画面会因显示语言略有不同。在本指南中，使用英语画面进行基本说明。

關於詳細指示，請參閱使用說明書。

另外，不同顯示語言的按鍵及畫面會有所差異。在本說明書中，基本說明均以英文畫面為準。

자세한 내용은 작동 설명서를 참조하세요.

언어에 따라 키와 화면이 다릅니다. 이 안내서에서는 영어 화면을 기준으로 설명합니다.

<English display>

<英语画面>

<英語顯示>

<영어 표시>

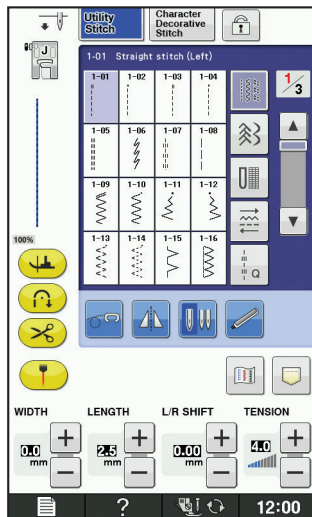

<Example: Simplified Chinese>

<示例：简体中文>

<範例：簡體中文>

<예: 중국어 간체>

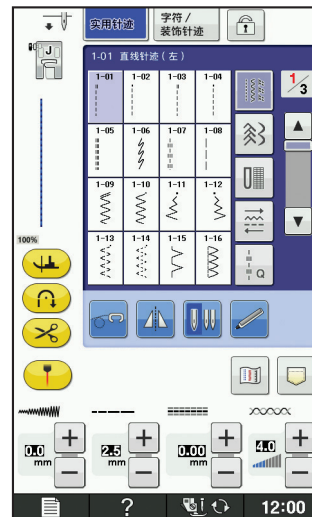

Contents

Winding the Bobbin	2
Setting the Bobbin	4
Upper Threading.....	5
Selecting Stitch Patterns	6
Summary of Stitch Patterns.....	9

目录

梭芯绕线	2
设置梭芯	4
面线穿线	5
选择针迹花样	6
针迹花样摘要	9

目錄

梭子繞線	2
安裝梭子	4
穿上線	5
選擇針趾花樣	6
刺繡花樣概要	9

목차

실토리 감기	2
실토리 설정	4
윗실 끼우기	5
재봉 패턴 선택	6
재봉 패턴 요약	9

Winding the Bobbin

梭芯绕线

梭子繞線

실토리 감기

Follow the numbered steps below in order. Refer to the operation manual for detailed instruction.
 遵循下面按顺序编号的步骤。有关详细说明，请参见使用说明书。
 依序按下列編號步驟進行。關於詳細指示，請參閱使用說明書。
 아래 번호 순서를 따르세요. 자세한 내용은 작동 설명서를 참조하세요.

Use only the enclosed bobbin or bobbins of the same type.
 仅使用随机附带的梭芯或者同类型的梭芯。
 只能使用随附的梭子或相同类型的梭子。
 동봉된 실토리 또는 같은 종류의 실토리만 사용하세요.

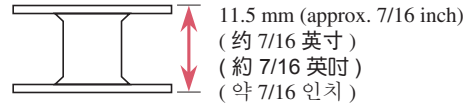

◆ Using the Supplemental Spool Pin

You can wind the bobbin during sewing.

◆ 使用辅助的线筒轴

您可以在绣制的过程中进行梭芯绕线。

◆ 使用輔助線輪柱

可以在縫紉過程中繞線。

◆ 보조 실패꽃이 사용

재봉 중에 실토리를 감을 수 있습니다.

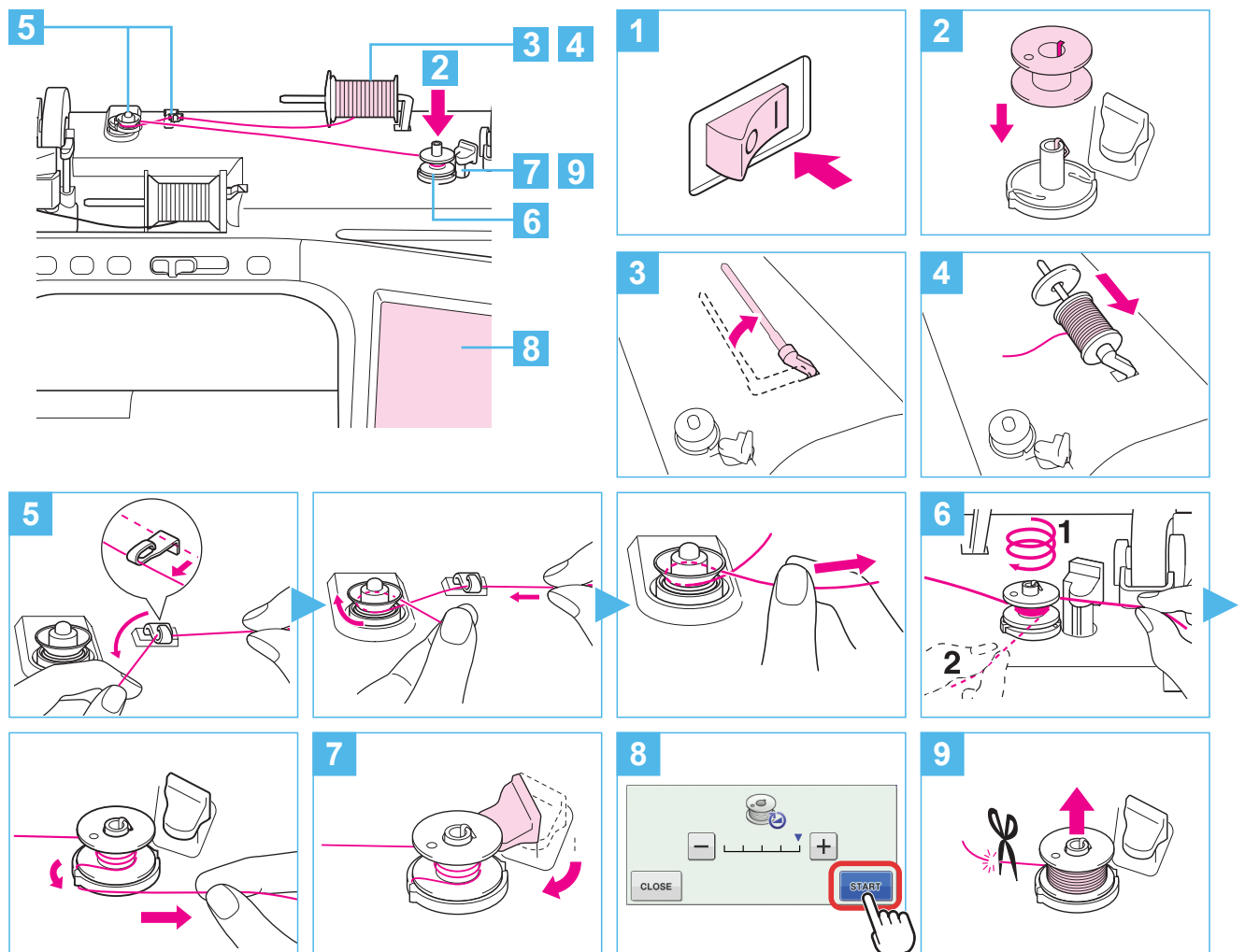

◆ **Using the Spool Pin**

You can use the main spool pin to wind the bobbin before sewing.

◆ **使用线筒轴**

可以在绣制之前使用主线筒轴进行梭芯绕线。

◆ **使用線輪柱**

縫紉前，可以使用主線輪柱來繞線。

◆ **실패꽃이 사용**

재봉 전에 메인 실패꽃이를 사용하여 실패토리를 감을 수 있습니다.

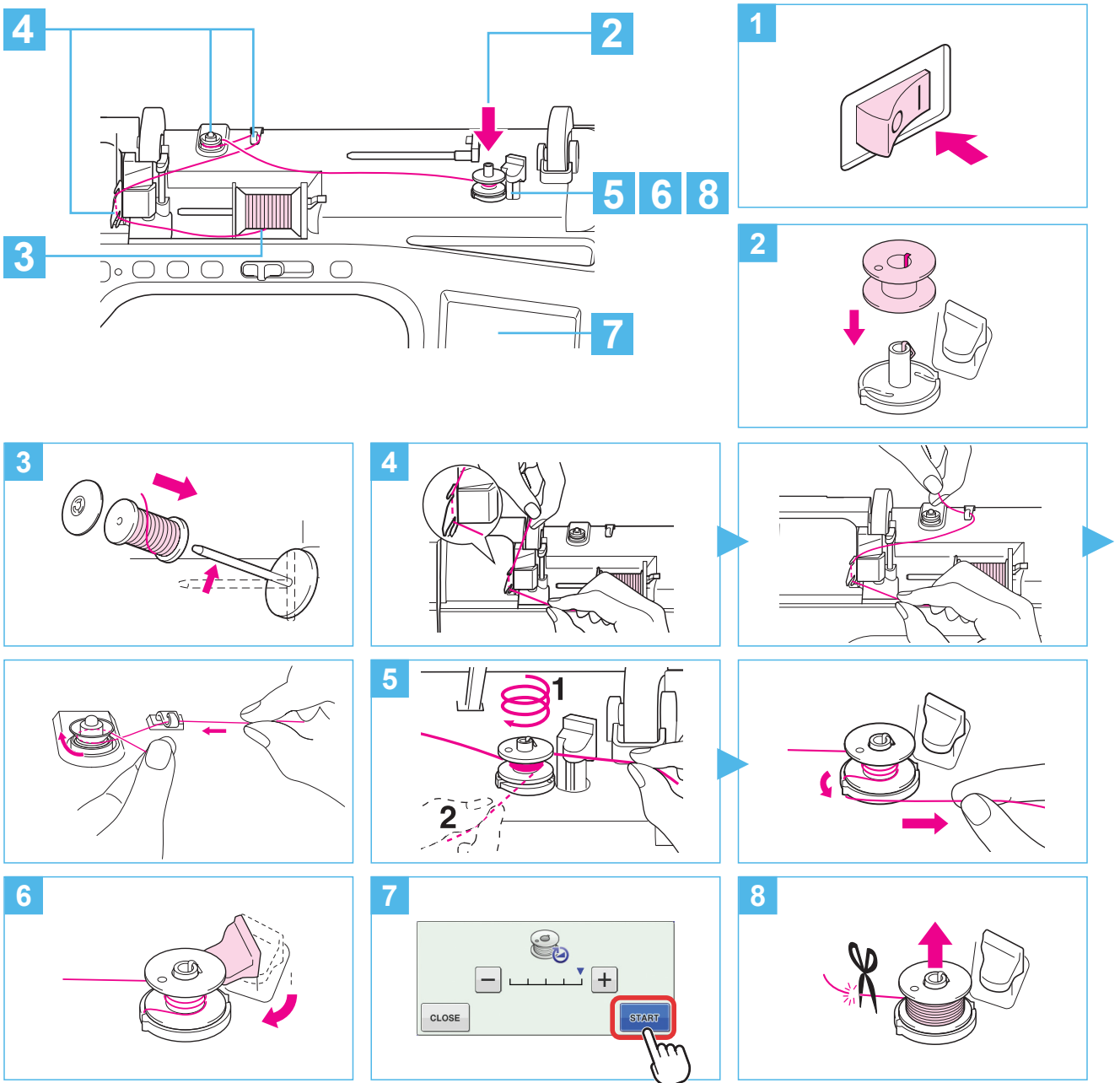

Setting the Bobbin

设置梭芯

安裝梭子

실토리 설정

Refer to the operation manual for detailed instruction.

有关详细说明，请参见使用说明书。

關於詳細指示，請參閱使用說明書。

자세한 내용은 작동 설명서를 참조하세요.

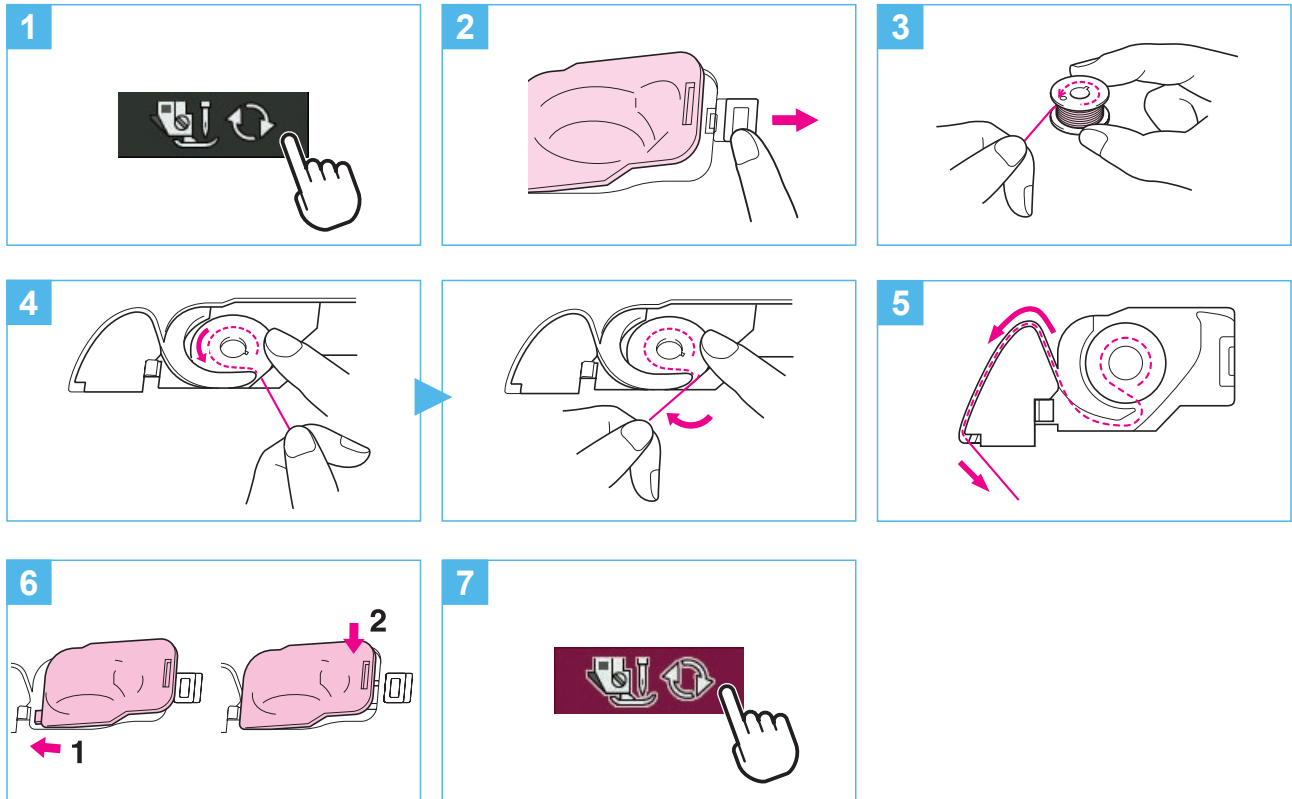

Upper Threading

面线穿线
穿上線
윗실 끼우기

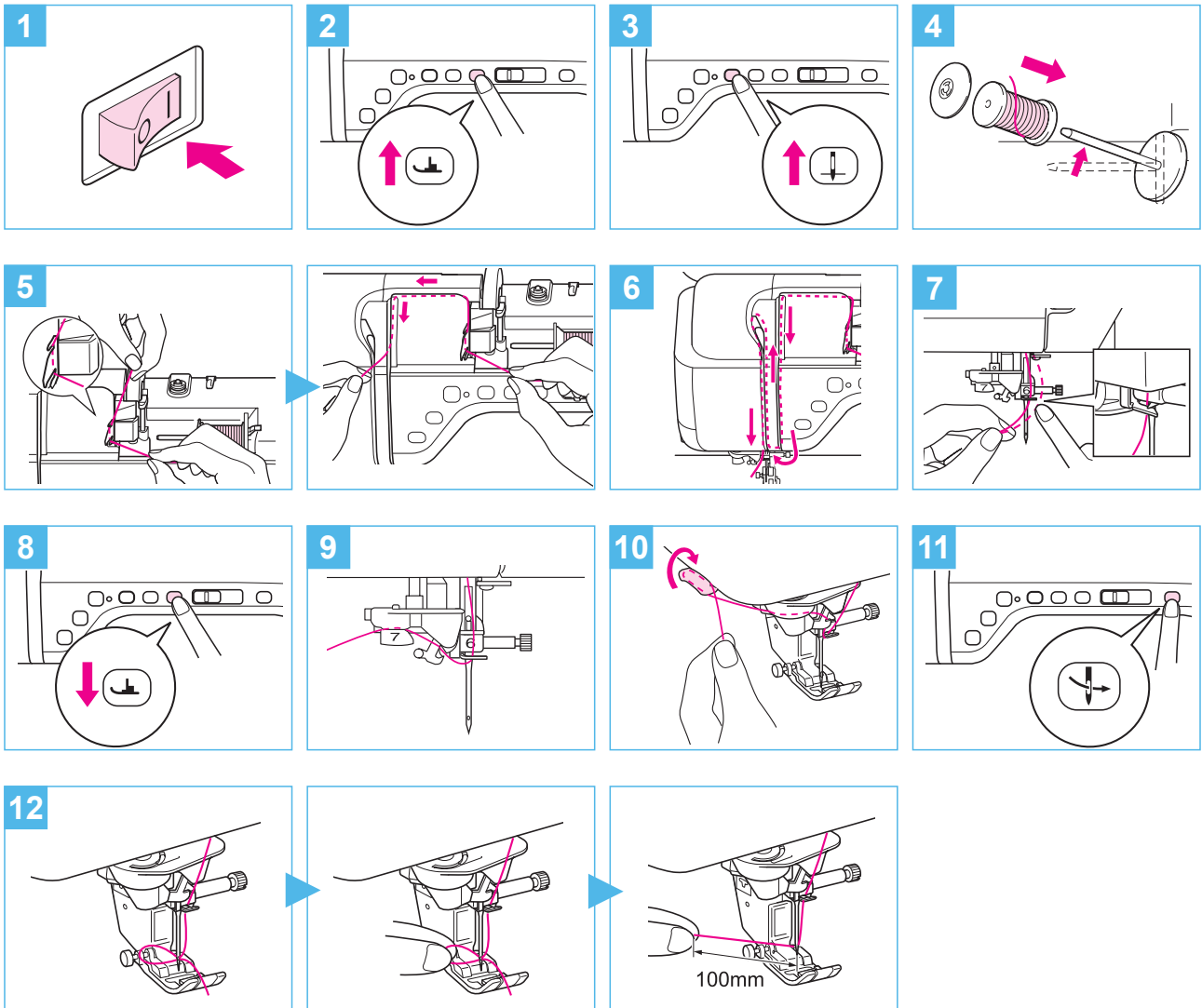
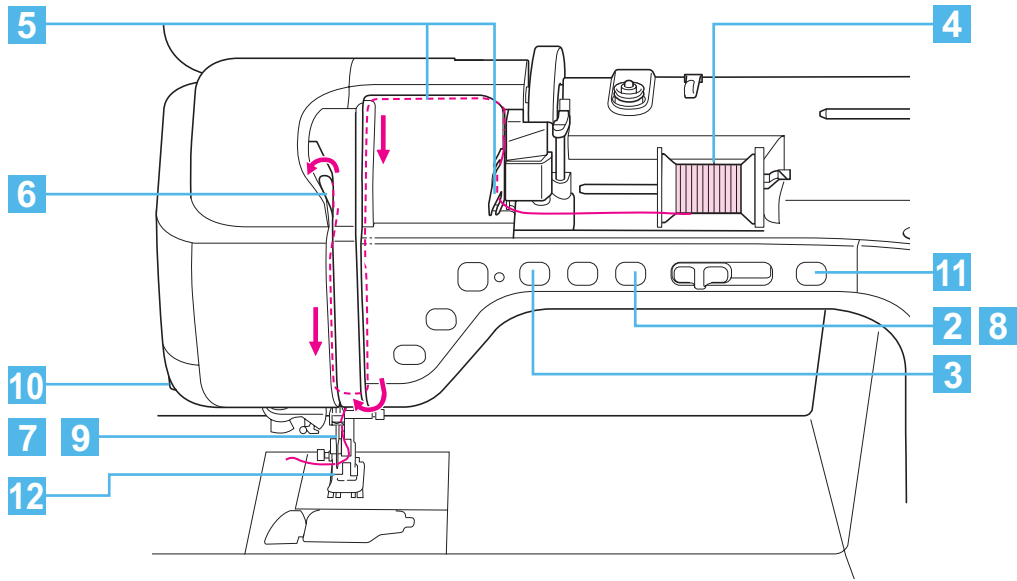

Selecting Stitch Patterns

选择针迹花样
選擇針跡花樣
재봉 패턴 선택

◆ LCD Flow Chart

◆ LCD 流程图

◆ LCD 流程圖

◆ LCD 플로 차트

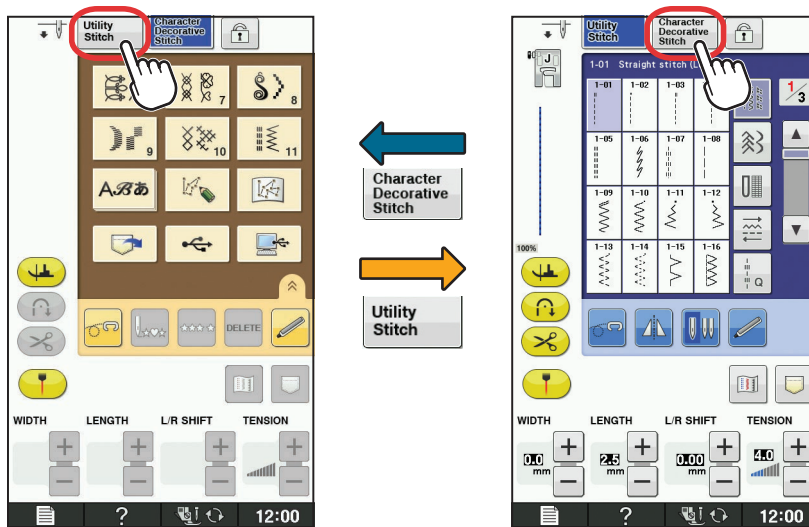

◆ Utility Stitches

When the machine is turned on, the opening movie is played. Touch the screen to display the Utility Stitch selection screen. Either "1-01 Straight stitch (Left)" or "1-03 Straight stitch (Middle)" is selected, depending on the setting selected in the settings screen.

◆ 实用针迹

当机器开启时,会显示开机动画。触摸屏幕以显示实用针迹选择画面。根据设置画面中所选择的设置,可以选择「1-01 直线针迹(左)」或「1-03 直线针迹(中)」。

◆ 實用針跡

本機開機後,會播放歡迎動畫。觸摸螢幕顯示實用針跡選擇畫面。因設定畫面中選擇的設定而異,選取「1-01 直線針跡(左針位)」或「1-03 直線針跡(中針位)」。

◆ 실용 재봉

기기가 켜질 때에 오프닝 동영상 이 재생됩니다. 화면을 터치하여 실용 재봉 선택 화면을 표시하세요. 설정 화면에서 선택한 설정에 따라 "1-01 직선 재봉 (왼쪽)" 또는 "1-03 직선 재봉 (가운데)" 가 선택됩니다.

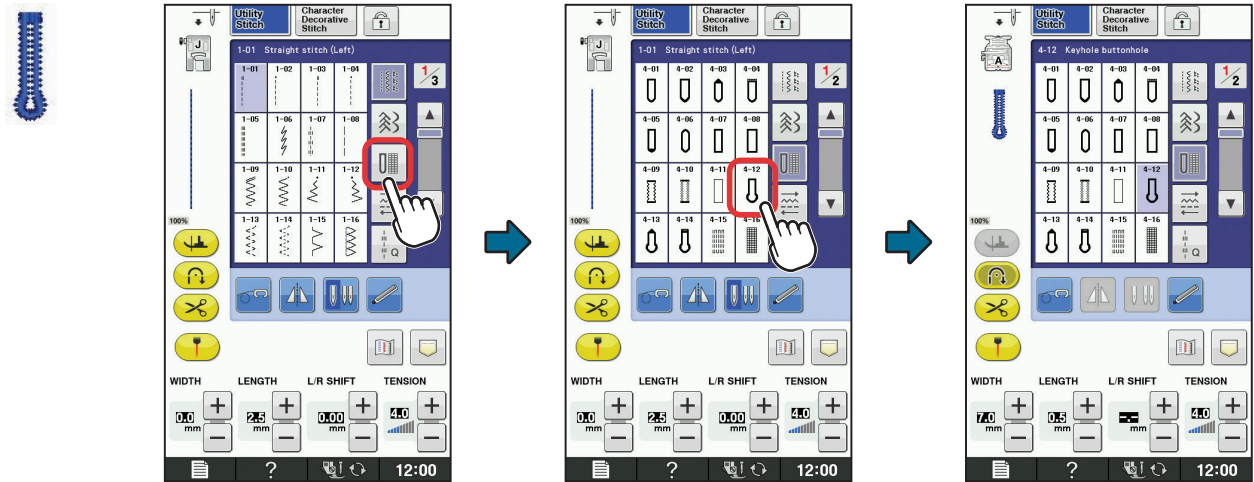

◆ Character/Decorative Stitches

◆ 字母 / 装饰针迹

◆ 文字 / 裝飾性針跡

◆ 문자 / 장식 재봉

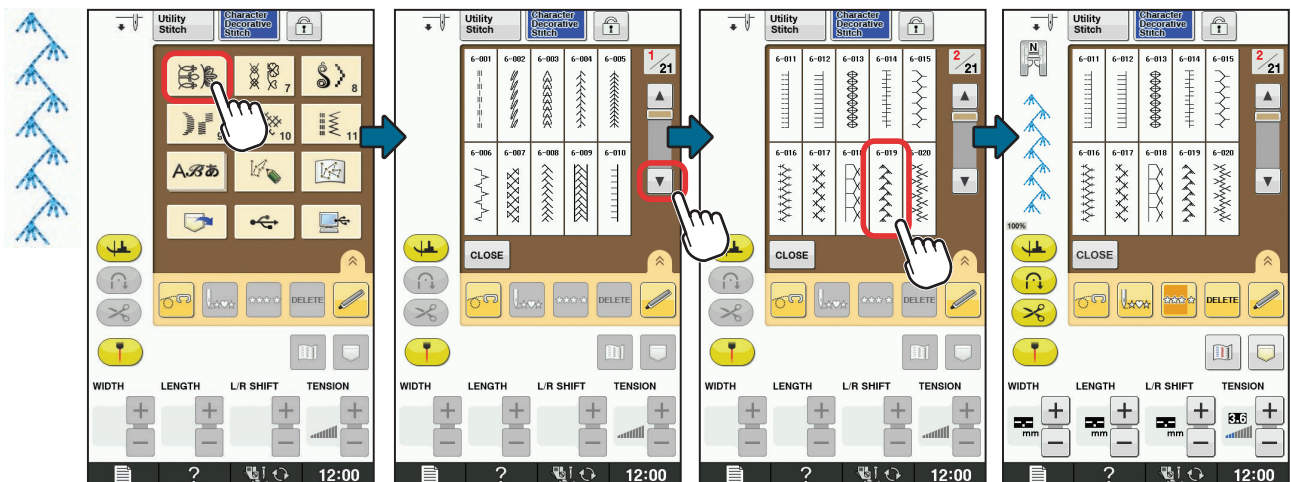

Selecting Stitch Patterns
 选择针迹花样
 選擇針跡花樣
 재봉 패턴 선택

◆ Settings

◆ 设置

◆ 設定

◆ 설정



Summary of Stitch Patterns

针迹花样摘要

刺繡花樣概要

재봉 패턴 요약

◆ Utility Stitches

◆ 实用针迹

◆ 實用針趾

◆ 실용 재봉

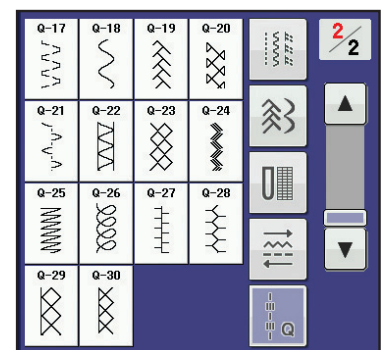
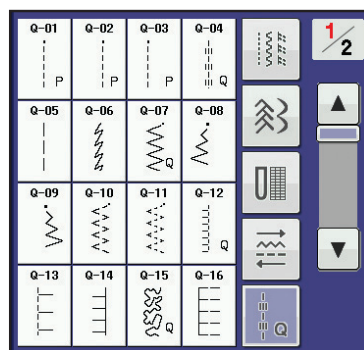
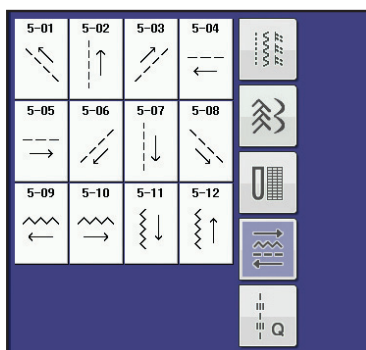
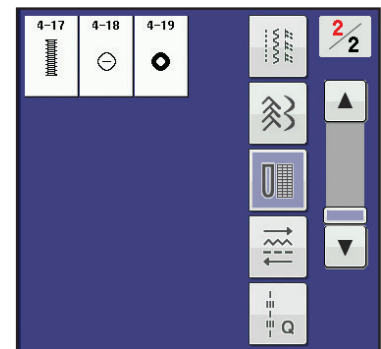
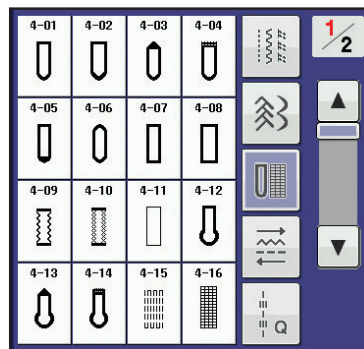
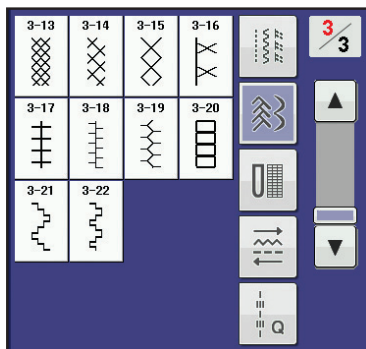
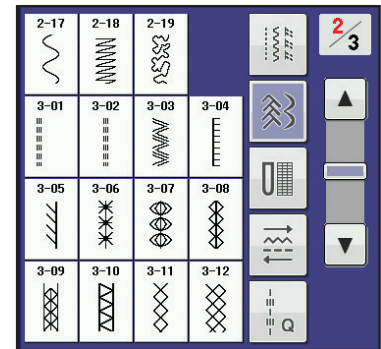
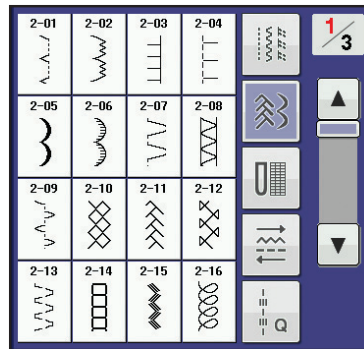
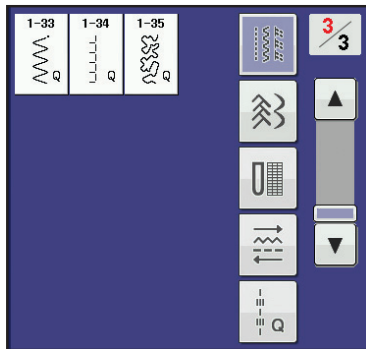
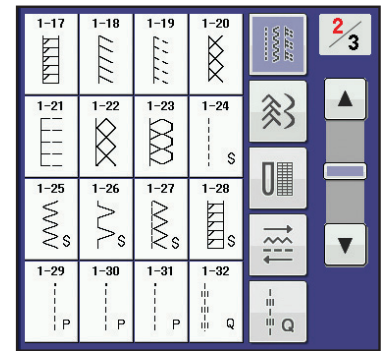
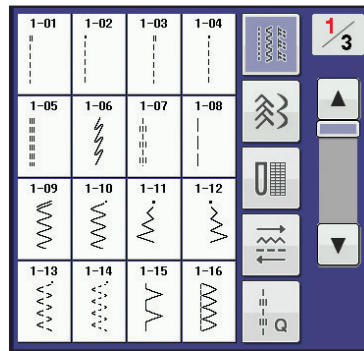
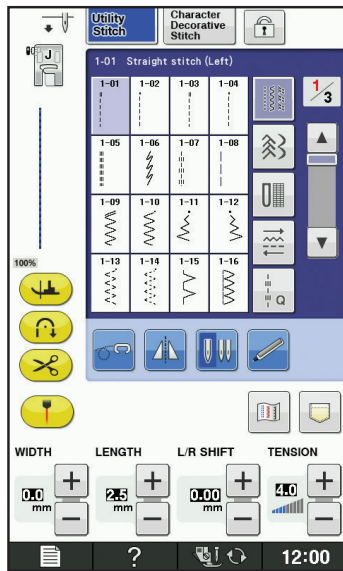

◆ Character/Decorative Stitches

◆ 字母 / 装饰针迹

◆ 文字 / 装饰性针迹

◆ 문자 / 장식 재봉

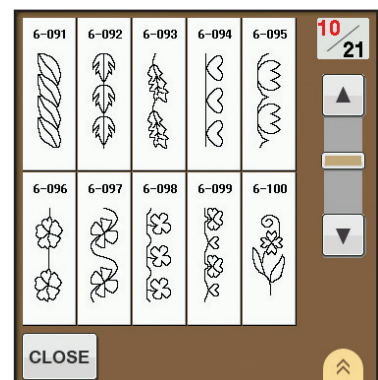
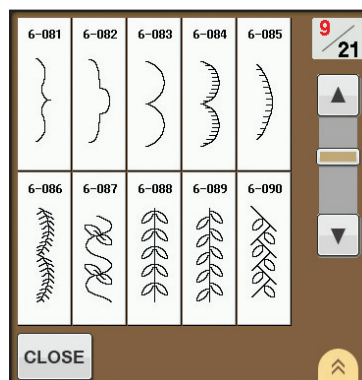
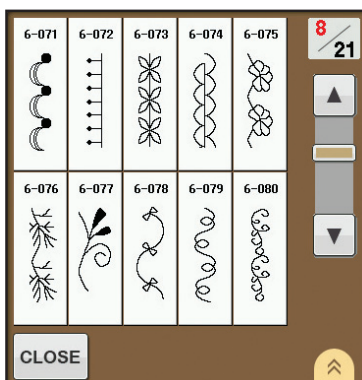
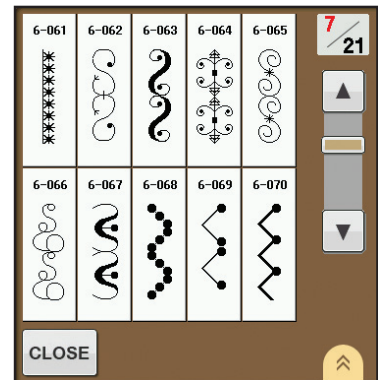
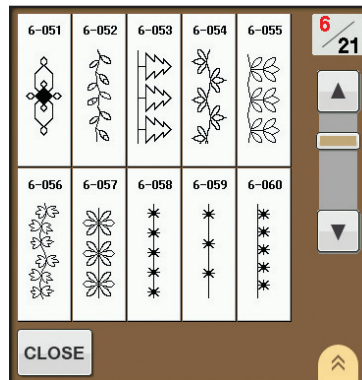
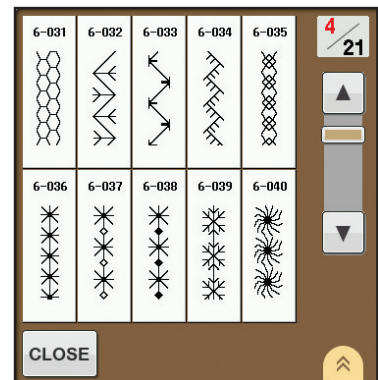
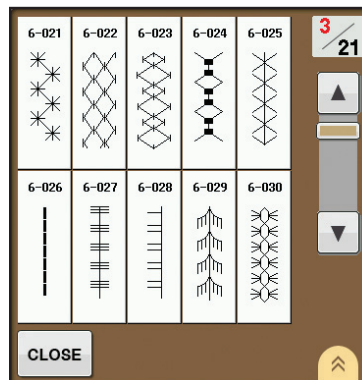
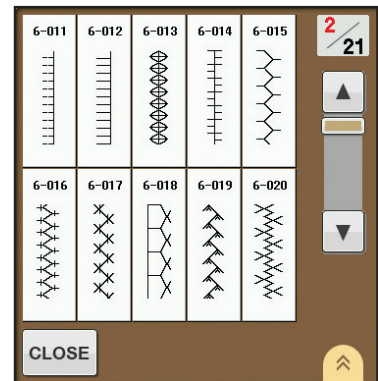
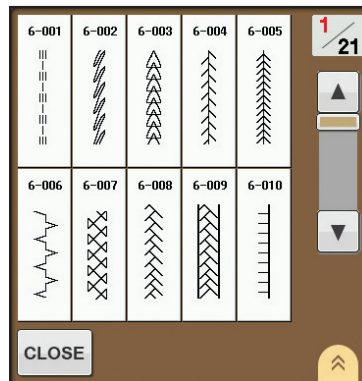
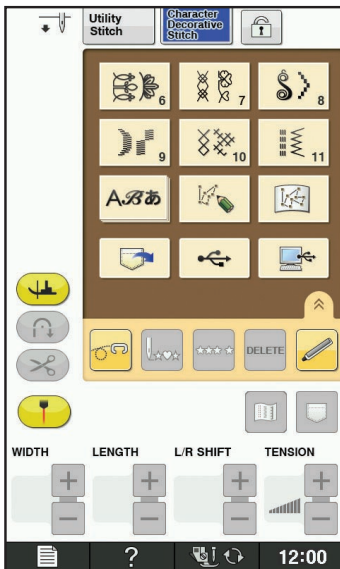

Summary of Stitch Patterns
 针迹花样摘要
 刺繡花樣概要
 재봉 패턴 요약

6-101	6-102	6-103	6-104	6-105	11 / 21
6-106	6-107	6-108	6-109	6-110	21
CLOSE					>>

6-111	6-112	6-113	6-114	6-115	12 / 21
6-116	6-117	6-118	6-119	6-120	21
CLOSE					>>

6-121	6-122	6-123	6-124	6-125	13 / 21
6-126	6-127	6-128	6-129	6-130	21
CLOSE					>>

6-131	6-132	6-133	6-134	6-135	14 / 21
6-136	6-137	6-138	6-139	6-140	21
CLOSE					>>

6-141	6-142	6-143	6-144	6-145	15 / 21
6-146	6-147	6-148	6-149	6-150	21
CLOSE					>>

6-151	6-152	6-153	6-154	6-155	16 / 21
6-156	6-157	6-158	6-159	6-160	21
CLOSE					>>

6-161	6-162	6-163	6-164	6-165	17 / 21
6-166	6-167	6-168	6-169	6-170	21
CLOSE					>>

6-171	6-172	6-173	6-174	6-175	18 / 21
6-176					21
CLOSE					>>

6-177	6-178	6-179	19 / 21		
CLOSE					>>

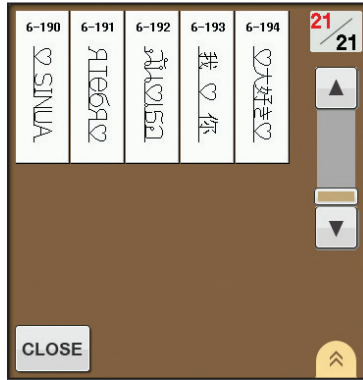
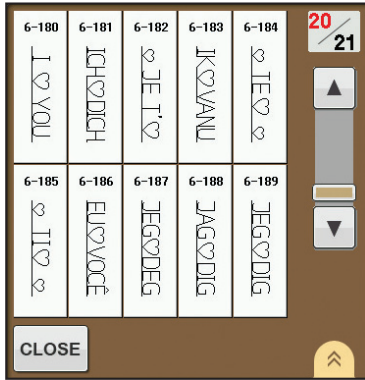

6-180: English
 6-181: German
 6-182: French
 6-183: Dutch
 6-184: Spanish
 6-185: Italian
 6-186: Portuguese
 6-187: Norwegian
 6-188: Swedish
 6-189: Danish
 6-190: Finnish
 6-191: Russian
 6-192: Thai
 6-193: Simplified Chinese
 6-194: Japanese

6-180: 英語
 6-181: 德語
 6-182: 法語
 6-183: 荷蘭語
 6-184: 西班牙語
 6-185: 義大利語
 6-186: 葡萄牙語
 6-187: 挪威語
 6-188: 瑞典語
 6-189: 丹麥語
 6-190: 芬蘭語
 6-191: 俄語
 6-192: 泰語
 6-193: 簡體中文
 6-194: 日語

6-180 : 英語
 6-181 : 德語
 6-182 : 法語
 6-183 : 荷蘭語
 6-184 : 西班牙語
 6-185 : 義大利語
 6-186 : 葡萄牙語
 6-187 : 挪威語
 6-188 : 瑞典語
 6-189 : 丹麥語
 6-190 : 芬蘭語
 6-191 : 俄語
 6-192 : 泰語
 6-193 : 簡體中文
 6-194 : 日語

6-180: 영어
 6-181: 독일어
 6-182: 프랑스어
 6-183: 네덜란드어
 6-184: 스페인어
 6-185: 이탈리아어
 6-186: 포르투갈어
 6-187: 노르웨이어
 6-188: 스웨덴어
 6-189: 덴마크어
 6-190: 핀란드어
 6-191: 러시아어
 6-192: 태국어
 6-193: 중국어 간체
 6-194: 일본어

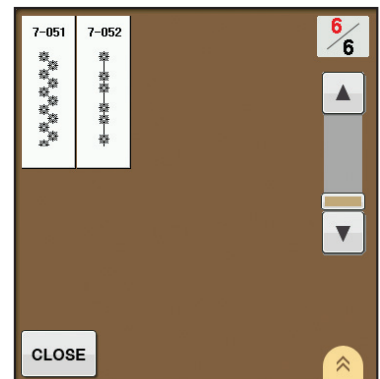
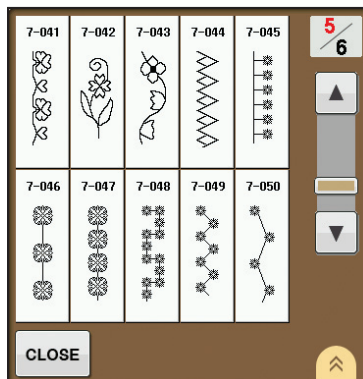
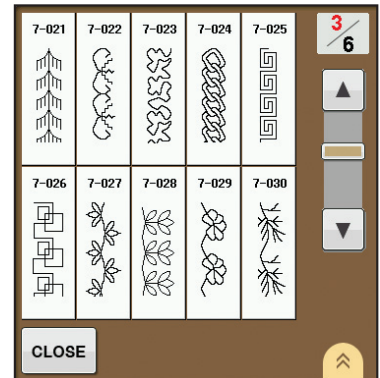
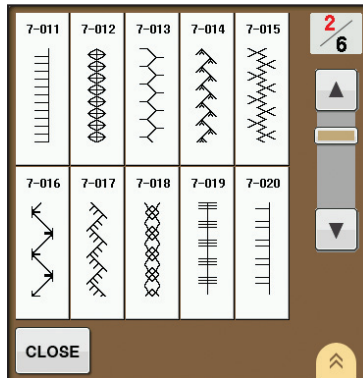
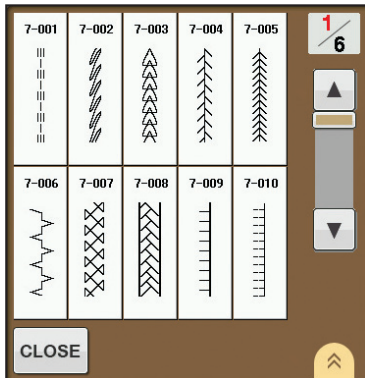
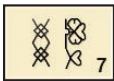

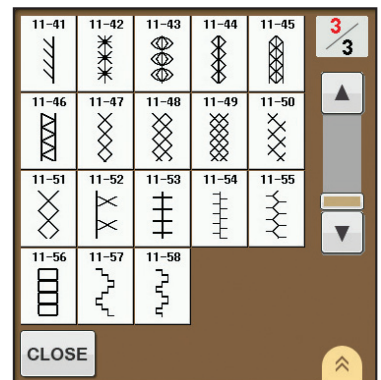
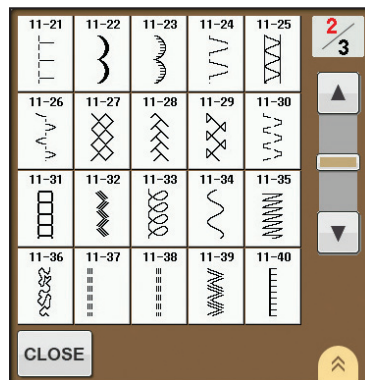
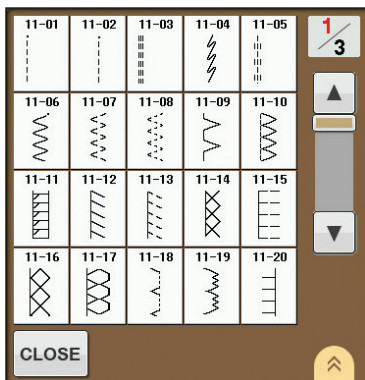
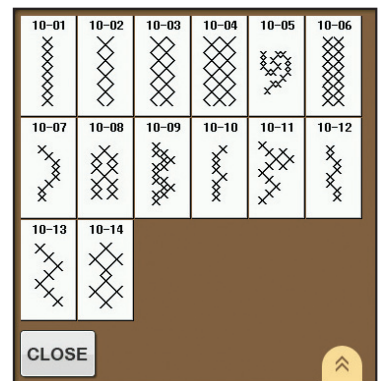
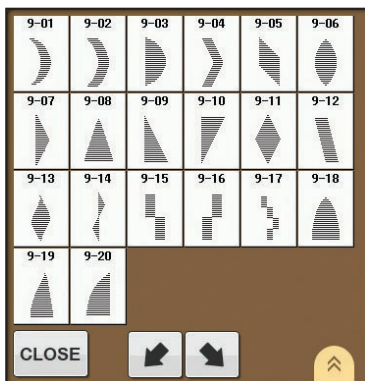
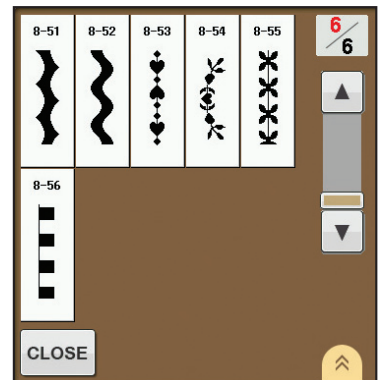
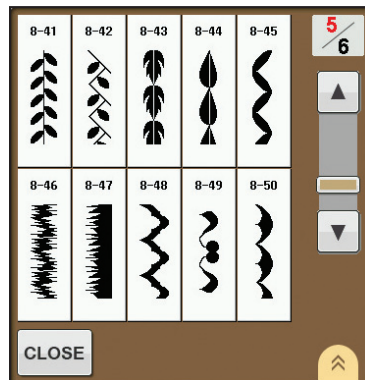
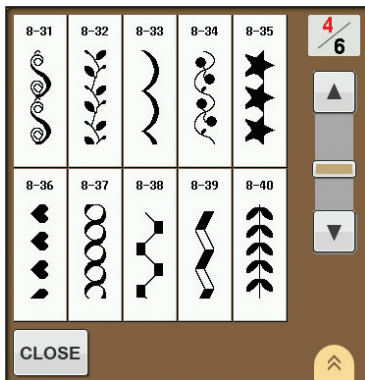
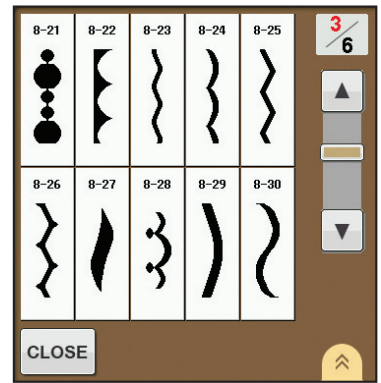
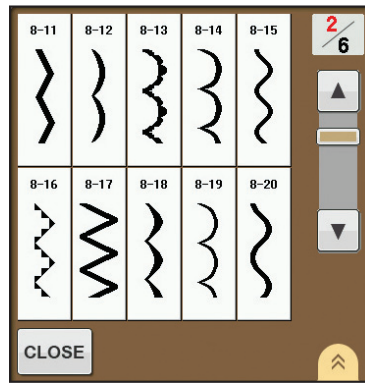
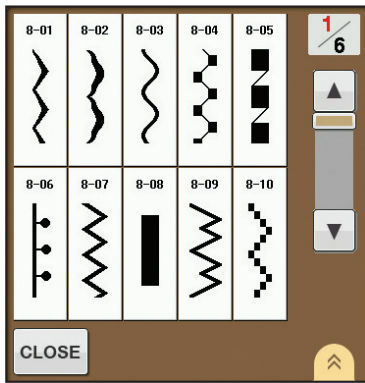

ABあ

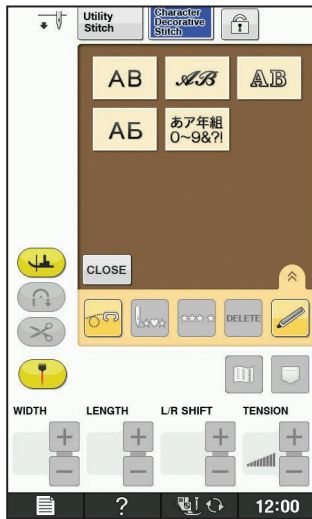

AB

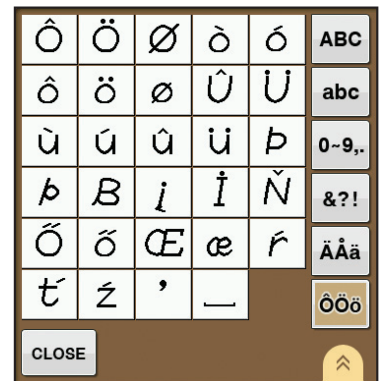
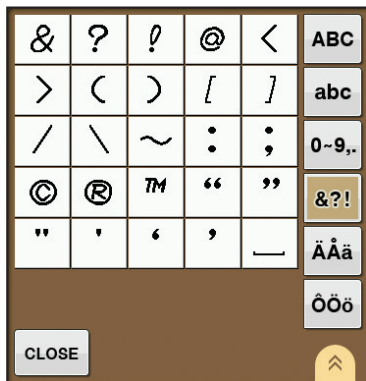

AB

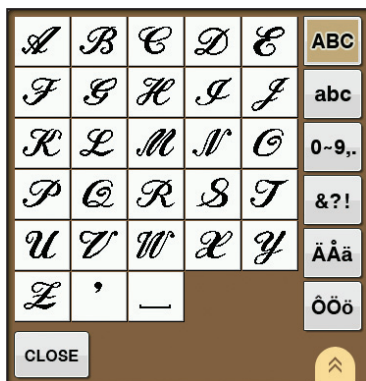

&	?	!	@	<	ABC
>	()	[]	abc
/	\	~	:	;	0-9,.
©	®	™	“	”	&?! ▲
”	'	‘	’	—	ÄÄä
					ÖÖö
CLOSE					▲

À	Á	Â	à	á	ABC
ä	å	ä	å	Æ	abc
æ	Ç	ç	È	É	0-9,.
Ê	Ë	è	é	ê	&?! ▲
ë	Ï	ì	í	Ð	ÄÄä
Ñ	ñ	Î	í	—	ÖÖö
CLOSE					▲

Ô	Õ	Ö	ò	ó	ABC
ô	ö	ø	Ù	Ú	abc
ù	ú	û	ü	Ï	0-9,.
Þ	ß	ì	Ï	Ñ	&?! ▲
Ó	ó	œ	æ	ƒ	ÄÄä
ƒ	z	'	—		ÖÖö
CLOSE					▲

AB

A	B	C	D	E	ABC
F	G	H	I	J	abc
K	L	M	N	O	0-9,.
P	Q	R	S	T	&?! ▲
U	V	W	X	Y	ÄÄä
Z	'	—			ÖÖö
CLOSE					▲

a	b	c	d	e	ABC
f	g	h	i	j	abc ▲
k	l	m	n	o	0-9,.
p	q	r	s	t	&?! ▲
u	v	w	x	y	ÄÄä
z	'	—			ÖÖö
CLOSE					▲

0	1	2	3	4	ABC
5	6	7	8	9	abc
#	%	\$	£	€	0-9,.
¥	□	+	×	÷	&?! ▲
≡	*	o	,	'	ÄÄä
—					ÖÖö
CLOSE					▲

&	?	!	@	<	ABC
>	()	[]	abc
/	\	~	:	;	0-9,.
©	®	™	“	”	&?! ▲
”	'	‘	’	—	ÄÄä
					ÖÖö
CLOSE					▲

Â	Ã	Ä	à	á	ABC
â	ã	ä	å	Æ	abc
æ	Ç	ç	È	É	0-9,.
Ê	Ë	è	é	ê	&?! ▲
ë	Ï	ì	í	Ð	ÄÄä
Ñ	ñ	Î	í	—	ÖÖö
CLOSE					▲

Ô	Õ	Ö	ò	ó	ABC
ô	ö	ø	Ù	Ú	abc
ù	ú	û	ü	Ï	0-9,.
Þ	ß	ì	Ï	Ñ	&?! ▲
Ó	ó	œ	æ	ƒ	ÄÄä
ƒ	z	'	—		ÖÖö
CLOSE					▲

AB

A	Б	В	Г	Д	АБВ
Е	Ё	Ж	З	И	ЧШЩ
Й	К	Л	М	Н	абв
О	П	Р	С	Т	чшщ
У	Ф	Х	Ц	—	0-9,.
CLOSE					▲

Ч	Ш	Щ	Ь	Ы	АБВ
ь	э	ю	я	Г	ЧШЩ ▲
е	і	ї	ў	Һ	абв
Һ	Ј	Јь	Њ	Ц	чшщ
Ѓ	Ѕ	Ї	—		0-9,.
CLOSE					▲

a	б	в	г	д	АБВ
е	ё	ж	з	и	ЧШЩ
й	к	л	м	н	абв ▲
о	п	р	с	т	чшщ
у	ф	х	ц	—	0-9,.
CLOSE					▲

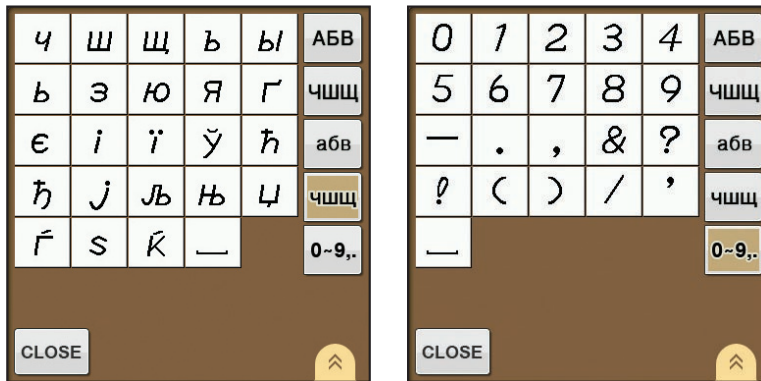

**あア年組
0~9&?!** *

Hiragana characters: One of the character sets of Japanese.
 Hiragana 字符：日语字符集中的一种。
 平假名字符：一種日文字符集。
 히라가나 문자: 일본어 문자 집합의 하나.

Katakana characters: One of the character sets of Japanese.
 Katakana 字符：日语字符集中的一种。
 片假名字符：一種日文字符集。
 가타가나 문자: 일본어 문자 집합의 하나.



Arabic numerals, Japanese Kanji numerals
 阿拉伯数字、日本汉字数字
 阿拉伯数字、日文汉字数字
 아라비아 숫자, 일본어 간지 숫자

Kanji characters often used in daily life / symbols.
 汉字字符常用于日常生活或符号。
 漢字常用於日常生活 / 符號。
 간지 문자는 일상 생활 / 기호에 자주 사용됩니다.

Horizontal
 橫向
 水平
 가로

Vertical
 縱向
 垂直
 세로

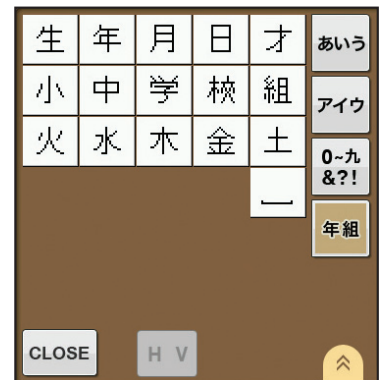
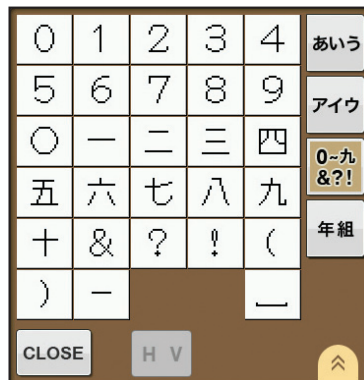
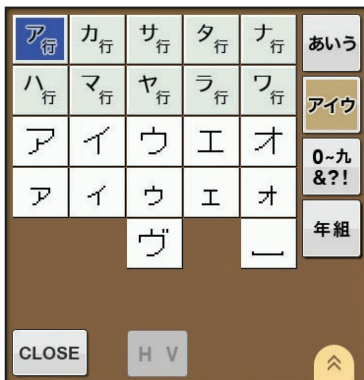

- * Japanese characters
- * 日语字符
- * 日文字
- * 일본어 문자

English
Chinese-simp
Chinese-trad
Korean

882-D00
Printed in Taiwan



XF5655-001