



刺しゅう機付コンピューターミシン

操作早見表 模様一覧

EMP08/09シリーズ

●必ず取扱説明書をお読みの上お使いください。



お知らせ

各模様の刺しゅうの時間と大きさは画面に表示される情報と異なることがあります。
参考目的としてのみお使いください。

目次

無線 LAN 接続機能	2
実用・その他の模様ぬい	
模様を選択してぬう	4
模様一覧	7
刺しゅう	
刺しゅう模様を選択して、刺しゅうする	12
刺しゅう模様一覧	14
刺しゅう色替え表	28
刺しゅうアレンジ例	40
色比較表	42
フォント名一覧	44

- 最初に取扱説明書の「安全にお使いいただくために」を必ずお読みください。
- 詳しい手順については、取扱説明書を参照してください。
- 画面および仕様は、改良のため予告なく変更することがあります。

無線 LAN 接続機能

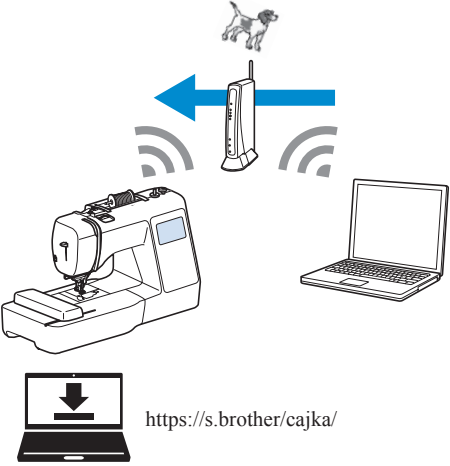
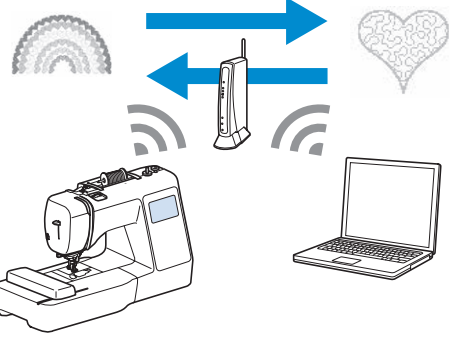

◆無線LAN接続でできること

 <p>https://s.brother/cajka/</p>	<p>Windows 専用アプリ（Design Database Transfer）を使ってパソコンからミシンへ刺しゅう模様を無線転送することができます。</p> <p>下記の URL から、アプリをダウンロードすることができます。 https://s.brother/cajka/</p>
	<p>刺しゅうデータ作成ソフトウェア（刺しゅう PRO11 およびそれ以降のバージョン）で編集された刺しゅう模様をパソコンからミシンに無線転送できます。また、ミシンで編集した刺しゅう模様を刺しゅう PRO に転送できます。</p>

無線 LAN キーの表示が  のときは、更新ソフトウェアがブラザーのサポートサイトでリリースされています。

◆無線LAN接続

 お願い

初めて本機の電源を入れると、無線 LAN 接続に関する下記のメッセージが表示されます。設定をする場合は  を押し、手順  に進んでください。

無線LAN接続の設定をしてください。
無線接続ウィザードを開始します。

今はしない

OK

1

お使いのセキュリティー情報（SSID とネットワークキー）を確認し、書きとめます。

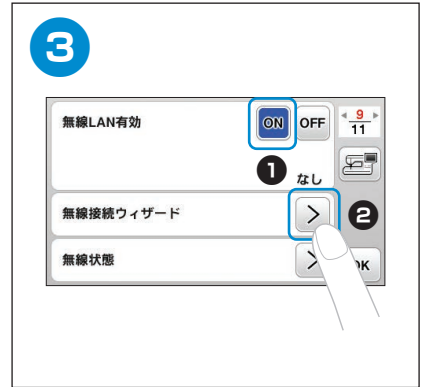
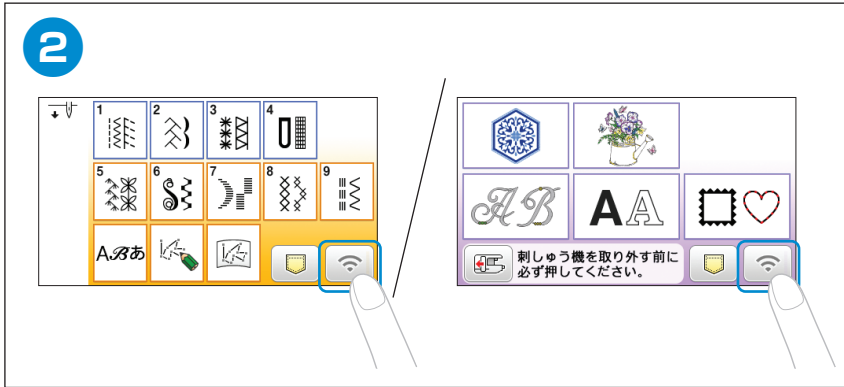

4

A screenshot of the 'SSID 選択...' (SSID Selection) screen. A list of SSIDs is shown: 'aaaaaaaaa', 'bbbbbbbbbb', and 'cccccccccc'. A hand is pointing to the right arrow button next to the first SSID. Below the list are navigation buttons: '針+押え交換' (Needle/Presser Exchange), '戻る' (Back), '進む' (Next), '実行文字模様' (Execute Text Pattern), '刺しゅう' (Embroidery), '設定' (Settings), and '使い方' (Usage).

手順 **1** で書きとめた SSID の横にある **>** を押します。
 • 書きとめた SSID を探すときは、**<** または **>** を押すと、前ページまたは次ページが表示されます。

5

A screenshot of the 'ネットワークキー' (Network Key) input screen. A QWERTY keyboard is shown with the 'OK' button highlighted. The input field contains asterisks. A hand is pointing to the 'OK' button.

書きとめたネットワークキー（パスワード）を入力して、**OK** を押します。

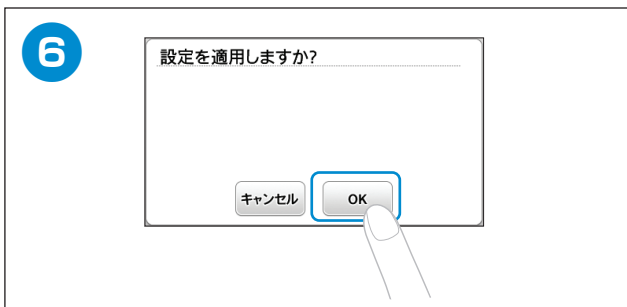

8

A screenshot of the wireless LAN settings menu. The '無線LAN有効' (Wireless LAN On) option is selected. The SSID 'aaaaaaaaa' is displayed. A hand is pointing to the 'OK' button at the bottom right of the screen.

OK を押して、セットアップを終了します。

模様を選択してぬう

お願い

- 下糸、上糸の準備については、かんたん操作ガイド、または取扱説明書を参照してください。
- 必要に応じて、ぬい始めとぬい終わりに、返しぬいまたは止めぬいをしてください。

◆ 実用模様

例:  を選択する

1 電源を入れます。

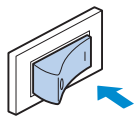

2 針上下スイッチで針を上げます。

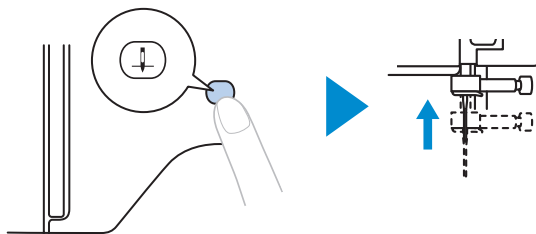

3 お好みの模様を表示するために、ページを送ります。

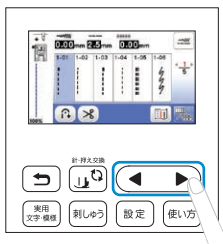

4 模様を選択します。

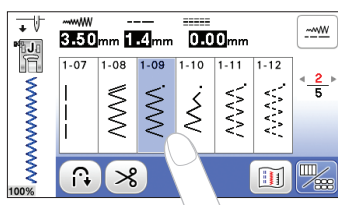

5 模様に適した押えが取り付けられていることを確認します。

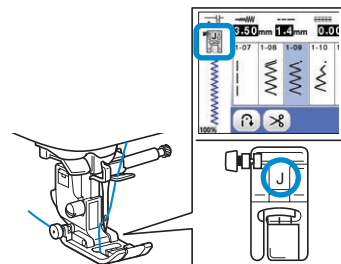

6 押えを上げます。

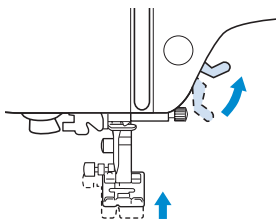

7 ぬい始めの位置に針を刺します。

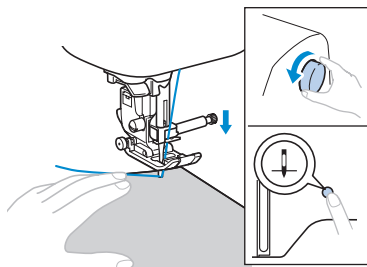

8 押えを下げます。

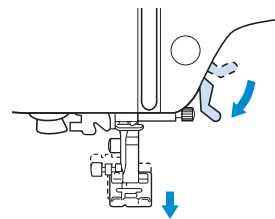

9 ぬいスピードを調節します。

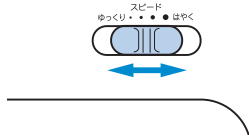

10 スタート/ストップスイッチを押して、ミシンをスタートさせます。

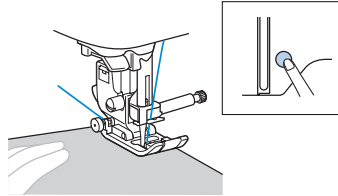

11 ぬい終わったら、もう一度スタート/ストップスイッチを押します。

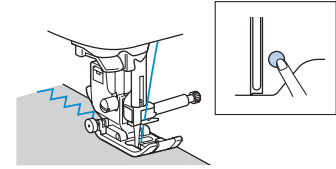

12 糸切りスイッチで糸を切ります。

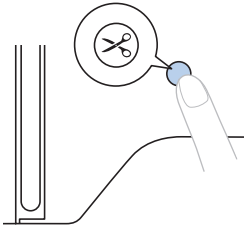

13 押えを上げます。

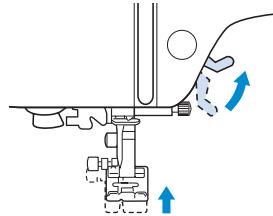

◆飾り模様

例： を選択する

1 電源を入れます。

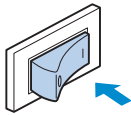

2  を押します。



3 模様の種類を選択します。

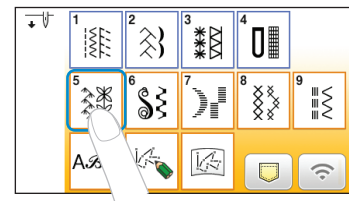

4 模様を選択します。

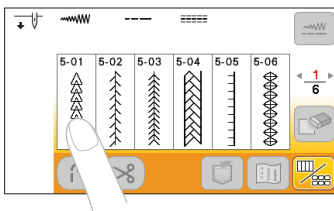

5 模様が選択されました。

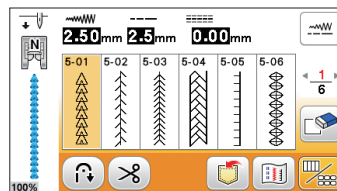

◆文字模様

例:「Bus」を選択する

- 1** 電源を入れます。

- 2** **実行文字模様** を押します。

- 3** 模様の種類を選択します。

- 4** 書体を選択します。

- 5** 文字を選択します。

- 6** お好みの文字を表示するために、ページを送ります。



- 7** 文字を選択します。

- 8** 文字を選択します。

- 9** 文字入力が完了しました。

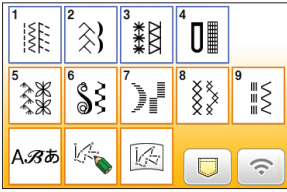

模様一覽



◆ 実用模様

• 1-01~1-30

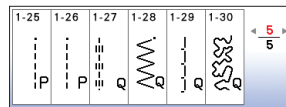
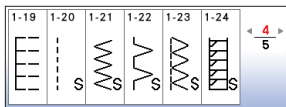
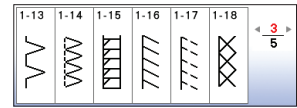
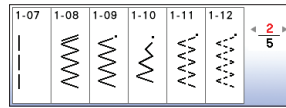
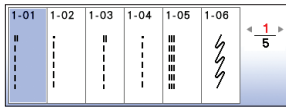

• 2-01~2-17

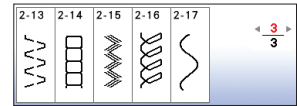
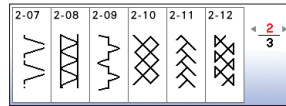
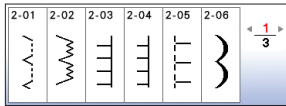

• 3-01~3-10

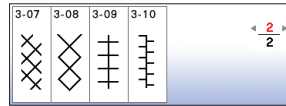
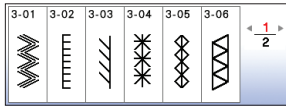

• 4-01~4-15

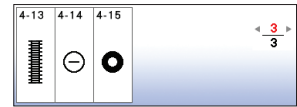
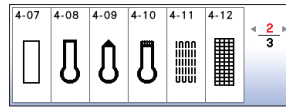
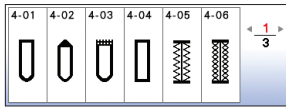

◆飾り模様

• 5-01~5-31

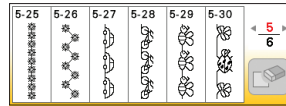
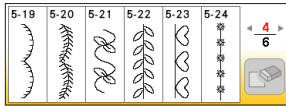
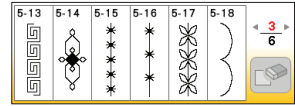
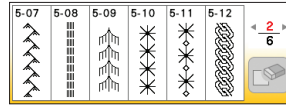
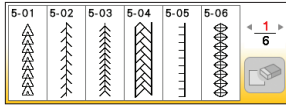

• 6-01~6-10

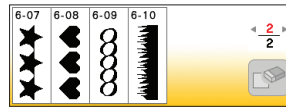

• 7-01~7-17

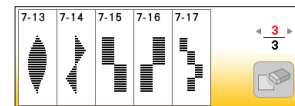
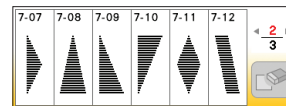
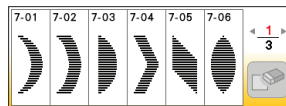

• 8-01~8-11

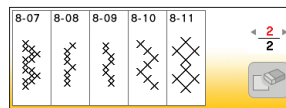
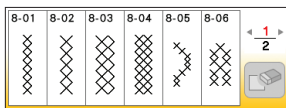

• 9-01~9-40

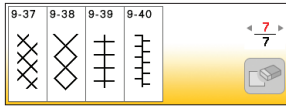
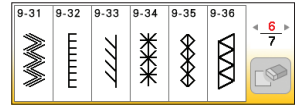
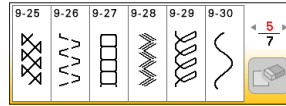
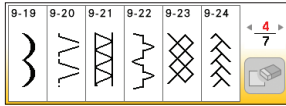
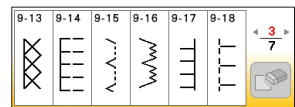
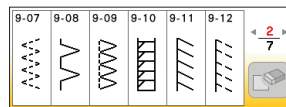
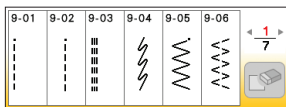

◆文字模様

A/B あ ▶ AB

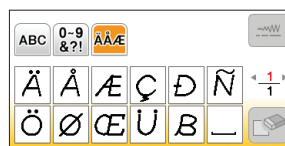
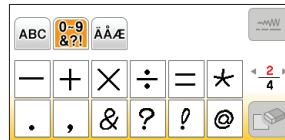
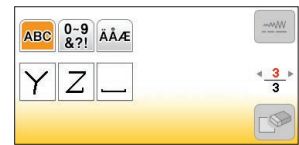
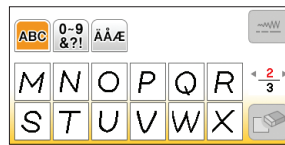

A/B あ ▶ AB

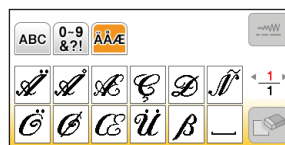
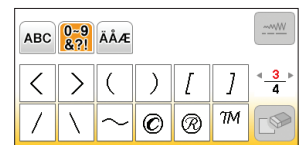
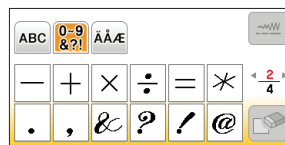
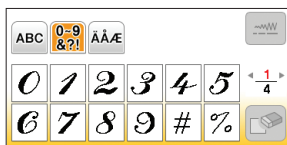
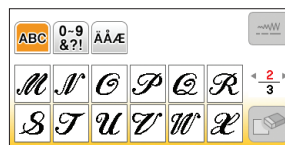
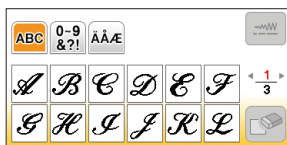

A/B あ ▶ AB

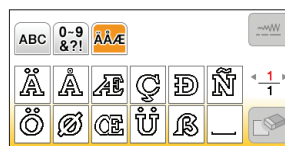
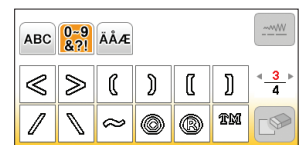
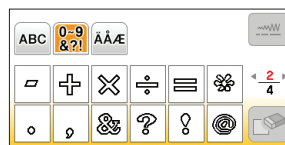
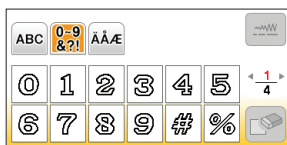
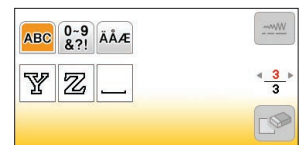
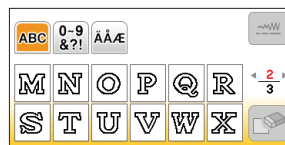

んあ

あア年組
0~9&

あいう	アイウ	0~9 &?!)	年組	→W
あ行	か行	さ行	た行	な行
は行	ま行	や行	ら行	わ行

1
1

あいう	アイウ	0~9 &?!)	年組	→W
あ	い	う	え	お
あ	い	う	え	お

1
11

あ行

あいう	アイウ	0~9 &?!)	年組	→W
あ	い	う	え	お
あ	い	う	え	お

1
11

か行

あいう	アイウ	0~9 &?!)	年組	→W
か	き	く	け	こ
が	ぎ	ぐ	げ	ご

2
11

さ行

あいう	アイウ	0~9 &?!)	年組	→W
さ	し	す	せ	そ
ざ	じ	ず	ぜ	ぞ

3
11

た行

あいう	アイウ	0~9 &?!)	年組	→W
た	ち	つ	て	と
だ	ぢ	づ	で	ど

4
11

な行

あいう	アイウ	0~9 &?!)	年組	→W
な	に	ぬ	ね	の

5
11

は行

あいう	アイウ	0~9 &?!)	年組	→W
は	ひ	ふ	へ	ほ
ば	び	ぶ	べ	ぼ

6
11

あいう	アイウ	0~9 &?!)	年組	→W
ぱ	ぴ	ぷ	ぺ	ぽ

7
11

ま行

あいう	アイウ	0~9 &?!)	年組	→W
ま	み	む	め	も

8
11

や行

あいう	アイウ	0~9 &?!)	年組	→W
や	ゆ	よ		
や	ゆ	よ		

9
11

ら行

あいう	アイウ	0~9 &?!)	年組	→W
ら	り	る	れ	ろ

10
11

わ行

あいう	アイウ	0~9 &?!)	年組	→W
わ	を	ん	ー	

11
11

あいう	アイウ	0~9 &?!)	年組	→W
ア行	カ行	サ行	タ行	ナ行
ハ行	マ行	ヤ行	ラ行	ワ行

1
1

あいう	アイウ	0~9 &?!)	年組	→W
ア	イ	ウ	エ	オ
ア	イ	ウ	エ	オ

1
11

ア行

あいう	アイウ	0~9 &?!)	年組	→W
ア	イ	ウ	エ	オ
ア	イ	ウ	エ	オ

1
11

カ行

あいう	アイウ	0~9 &?!)	年組	→W
カ	キ	ク	ケ	コ
ガ	ギ	グ	ゲ	ゴ

2
11

サ行

あいう	アイウ	0~9 &?!)	年組	→W
サ	シ	ス	セ	ソ
ザ	ジ	ズ	ゼ	ゾ

3
11

タ行

あいう	アイウ	0~9 &?!)	年組	→W
タ	チ	ツ	テ	ト
ダ	ヂ	ヅ	デ	ド

4
11

ナ行

あいう	アイウ	0~9 &?!)	年組	→W
ナ	ニ	ヌ	ネ	ノ

5
11

ハ行

あいう	アイウ	0~9 &?!)	年組	→W
ハ	ヒ	フ	ヘ	ホ
バ	ビ	ブ	ベ	ボ

6
11

あいう	アイウ	0~9 &?!)	年組	→W
パ	ピ	プ	ペ	ポ

7
11

マ行

あいう	アイウ	0~9 &?!)	年組	→W
マ	ミ	ム	メ	モ

8
11

模様一覧

ヤ行

あいう	アイウ	0-9 &?!	年組	→W
ヤ	ユ	ヨ	行↑	9/11
ヤ	ユ	ヨ		

あいう	アイウ	0-9 &?!	年組	→W			
0	1	2	3	4	5	行↑	1/3
6	7	8	9	0	-		

あいう	アイウ	0-9 &?!	年組	→W			
生	年	月	日	才	保	行↑	1/2
育	幼	稚	園	小	中		

ラ行

あいう	アイウ	0-9 &?!	年組	→W		
ラ	リ	ル	レ	□	行↑	10/11

あいう	アイウ	0-9 &?!	年組	→W			
二	三	四	五	六	七	行↑	2/3
八	九	十	&	?	!		

あいう	アイウ	0-9 &?!	年組	→W			
学	校	組	部	火	水	行↑	2/2
木	金	土	—				

ワ行

あいう	アイウ	0-9 &?!	年組	→W	
ワ	ヲ	ン	—	行↑	11/11

あいう	アイウ	0-9 &?!	年組	→W	
()	-	—	行↑	3/3

刺しゅう模様を選択して、刺しゅうする



- 刺しゅうの準備については、かんたん操作ガイド、または取扱説明書を参照してください。

1 刺しゅう模様の種類を選択します。

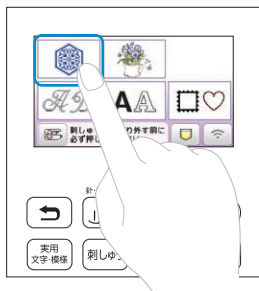

2 ワンポイント模様を選択します。

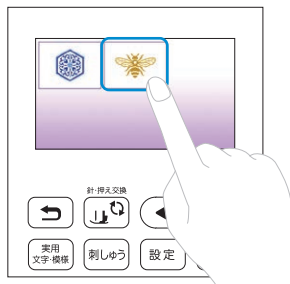

3 模様を選択します。

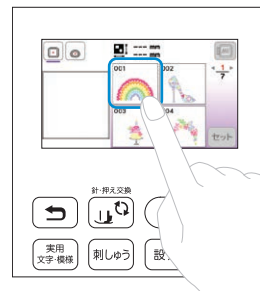

4 **セット** を押します。

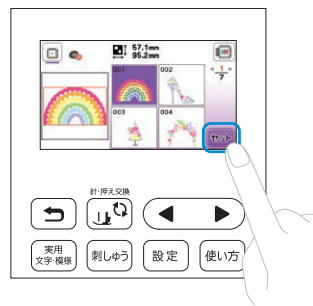

5 **編集終了** を押します。



6 **刺しゅう** を押します。



7 画面に表示された1色目の刺しゅう糸を用意します。

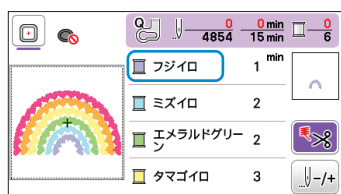

8 針に糸を通して、押えの穴に糸を入れ、左手で軽く糸を持ちます。

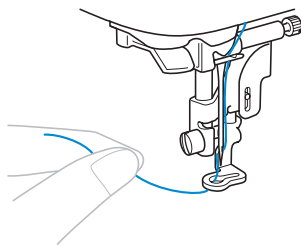

9 押えを下げます。

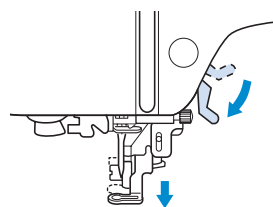

10 スタート/ストップスイッチを押して、ミシンをスタートします。

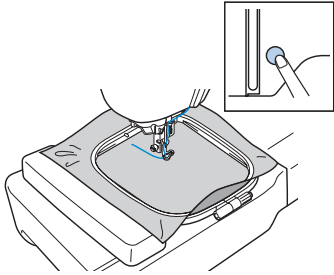

11 5～6針刺しゅうします。

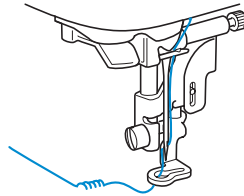

12 もう一度スタート/ストップボタンを押して、ミシンを止めます。

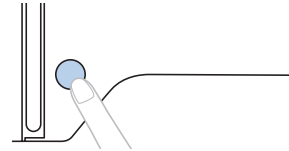

13 ぬい目のきわで余分な糸を切ります。

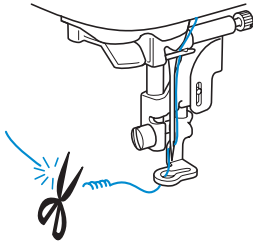

14 スタート/ストップスイッチを押して、刺しゅうを始めます。

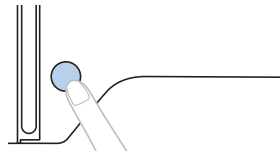

15 1色目の刺しゅうが終わると、ミシンが停止します。残りの色を同じ手順で刺しゅうします。

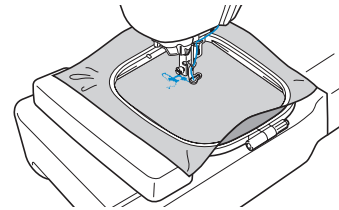

刺しゅう模様一覧

<i>AB</i>	AA	□ ♥
	刺しゅう機を取り外す前に必ず押してください。	

--	--	--

	001	002	◀ 1 ▶ 9
	003	004	セット

005	006	◀ 2 ▶ 9
007	008	セット

009	010	◀ 3 ▶ 9
011	012	セット

013	014	◀ 4 ▶ 9
015	016	セット

017	018	◀ 5 ▶ 9
019	020	セット

021	022	◀ 6 ▶ 9
023	024	セット

025	026	◀ 7 ▶ 9
027	028	セット

029	030	◀ 8 ▶ 9
031	032	セット

033	034	◀ 9 ▶ 9
035		セット

	001	002	◀ 1 ▶ 7
	003	004	セット

005	006	◀ 2 ▶ 7
007	008	セット

009	010	◀ 3 ▶ 7
011	012	セット

013	014	◀ 4 ▶ 7
015	016	セット

017	018	◀ 5 ▶ 7
019	020	セット

021	022	◀ 6 ▶ 7
023	024	セット

025		◀ 7 ▶ 7
		セット



001 	002 	◀ 1 ▶ 4
003 	004 	セット

005 	006 	◀ 2 ▶ 4
007 	008 	セット

009 	010 	◀ 3 ▶ 4
011 	012 	セット

013 	014 	◀ 4 ▶ 4
015 		セット



--	--



001 	002 	◀ 1 ▶ 8
003 	004 	セット

005 	006 	◀ 2 ▶ 8
007 	008 	セット

009 	010 	◀ 3 ▶ 8
011 	012 	セット

013 	014 	◀ 4 ▶ 8
015 	016 	セット

017 	018 	◀ 5 ▶ 8
019 	020 	セット

021 	022 	◀ 6 ▶ 8
023 	024 	セット

025 	026 	◀ 7 ▶ 8
027 	028 	セット

029 	030 	◀ 8 ▶ 8
		セット



001 	002 	◀ 1 ▶ 8
003 	004 	セット

005 	006 	◀ 2 ▶ 8
007 	008 	セット

009 	010 	◀ 3 ▶ 8
011 	012 	セット

013 	014 	◀ 4 ▶ 8
015 	016 	セット

017 	018 	◀ 5 ▶ 8
019 	020 	セット

021 	022 	◀ 6 ▶ 8
023 	024 	セット

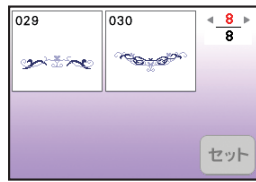

AA

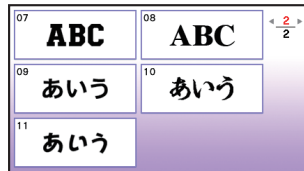
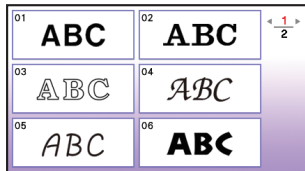

01 ABC

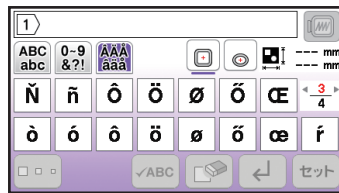
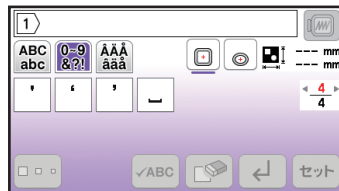
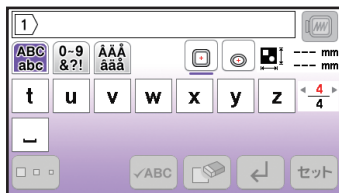
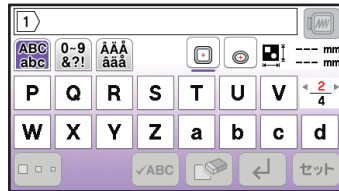
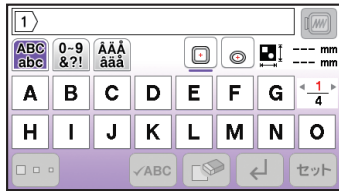

02 ABC

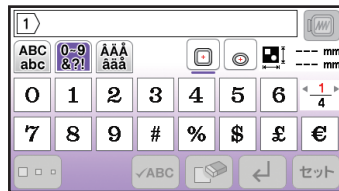
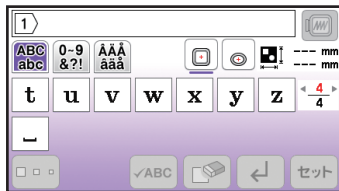
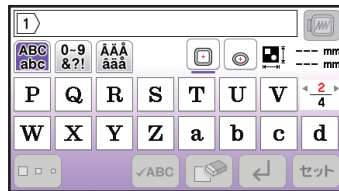

刺しゅう模様一覧

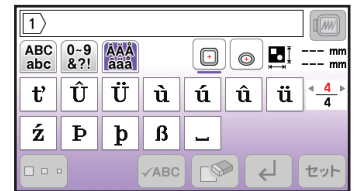
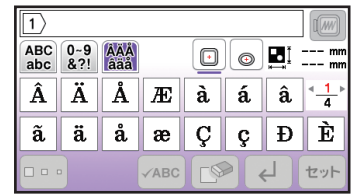
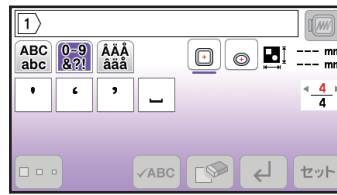
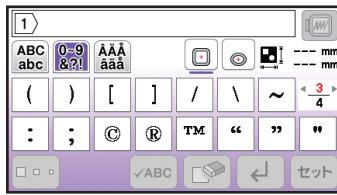

03 ABC

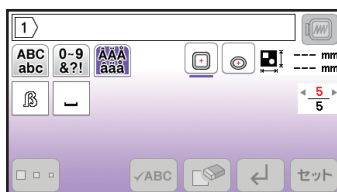
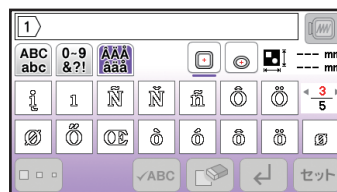
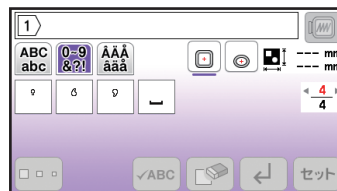
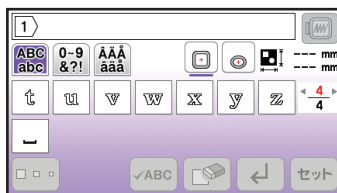
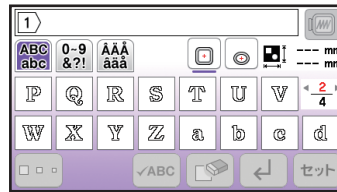
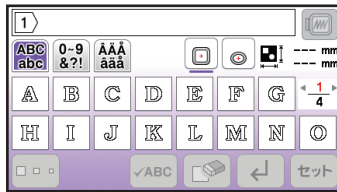

04 ABC

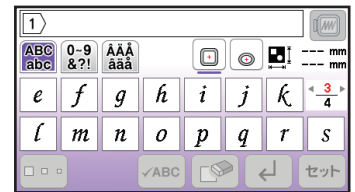
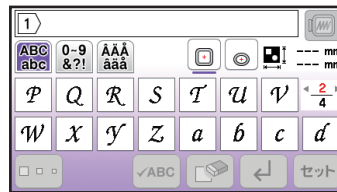
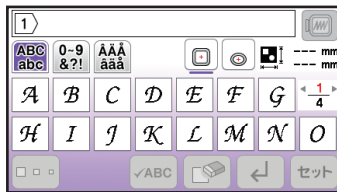

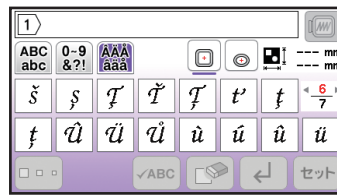
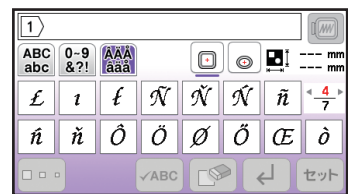
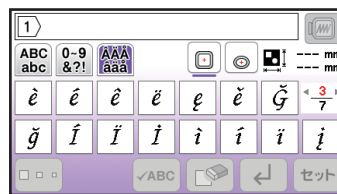
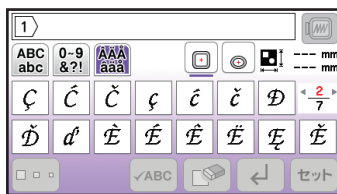
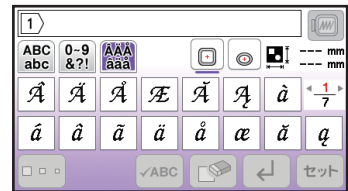
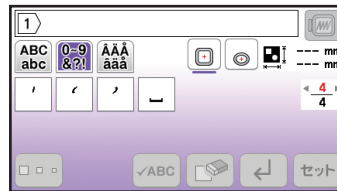
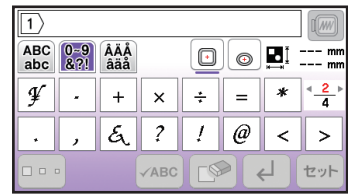

05 ABC

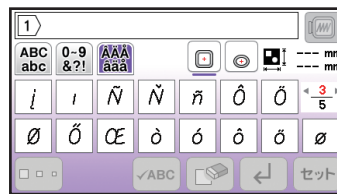
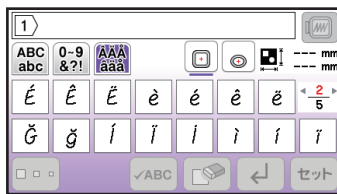
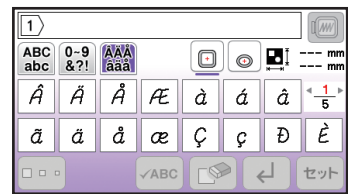
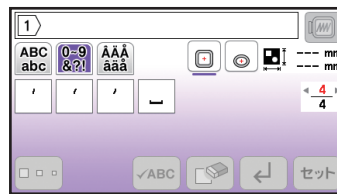
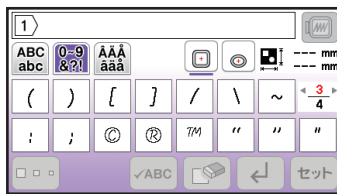
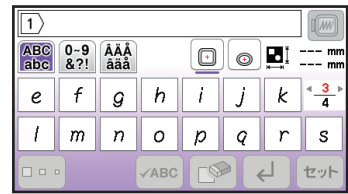
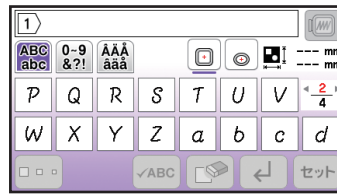

刺しゅう模様一覧

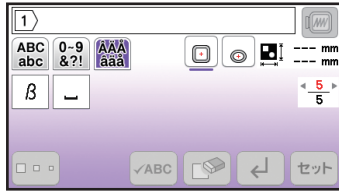

06 **ABC**

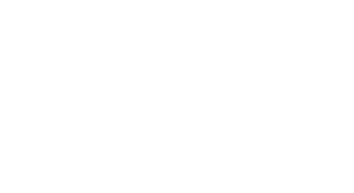
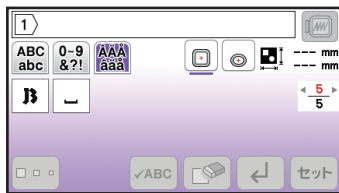
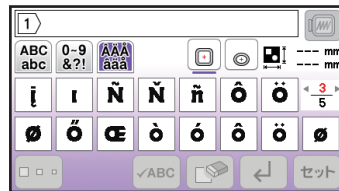
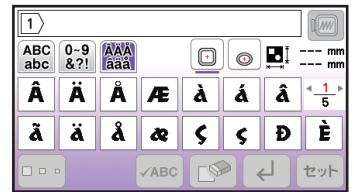
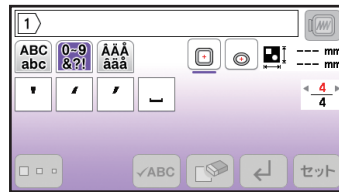
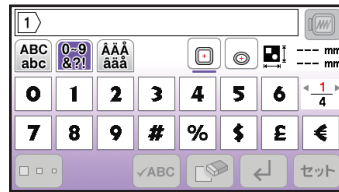
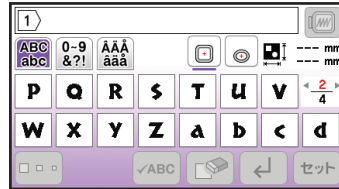

07 **ABC**

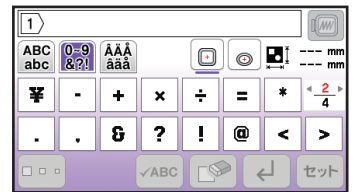
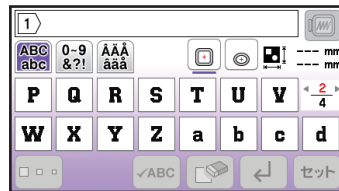
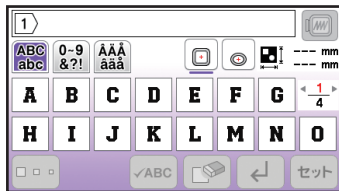

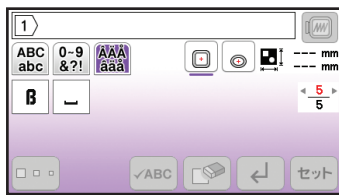
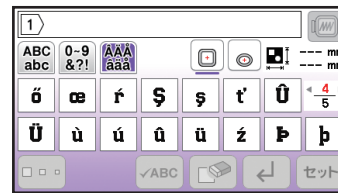
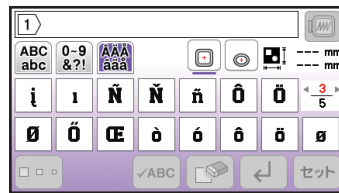
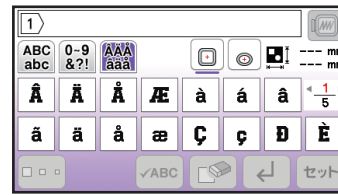
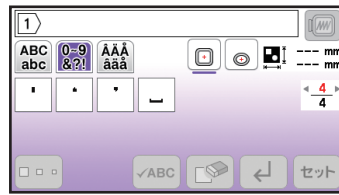

08 ABC

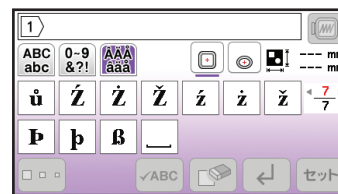
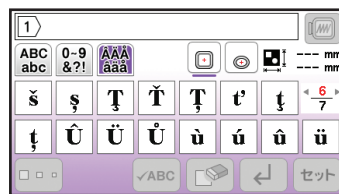
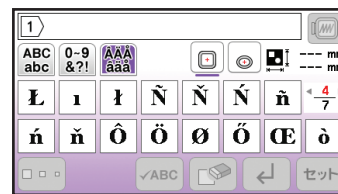
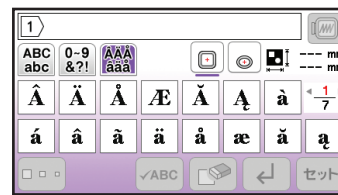
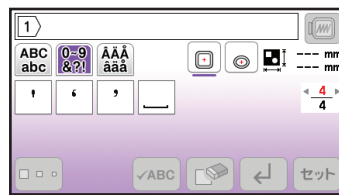
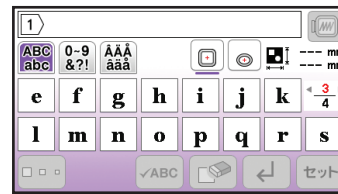
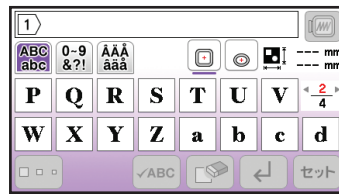
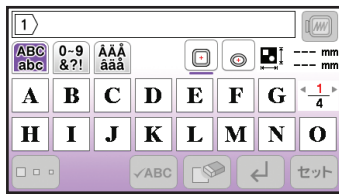

● 実寸例

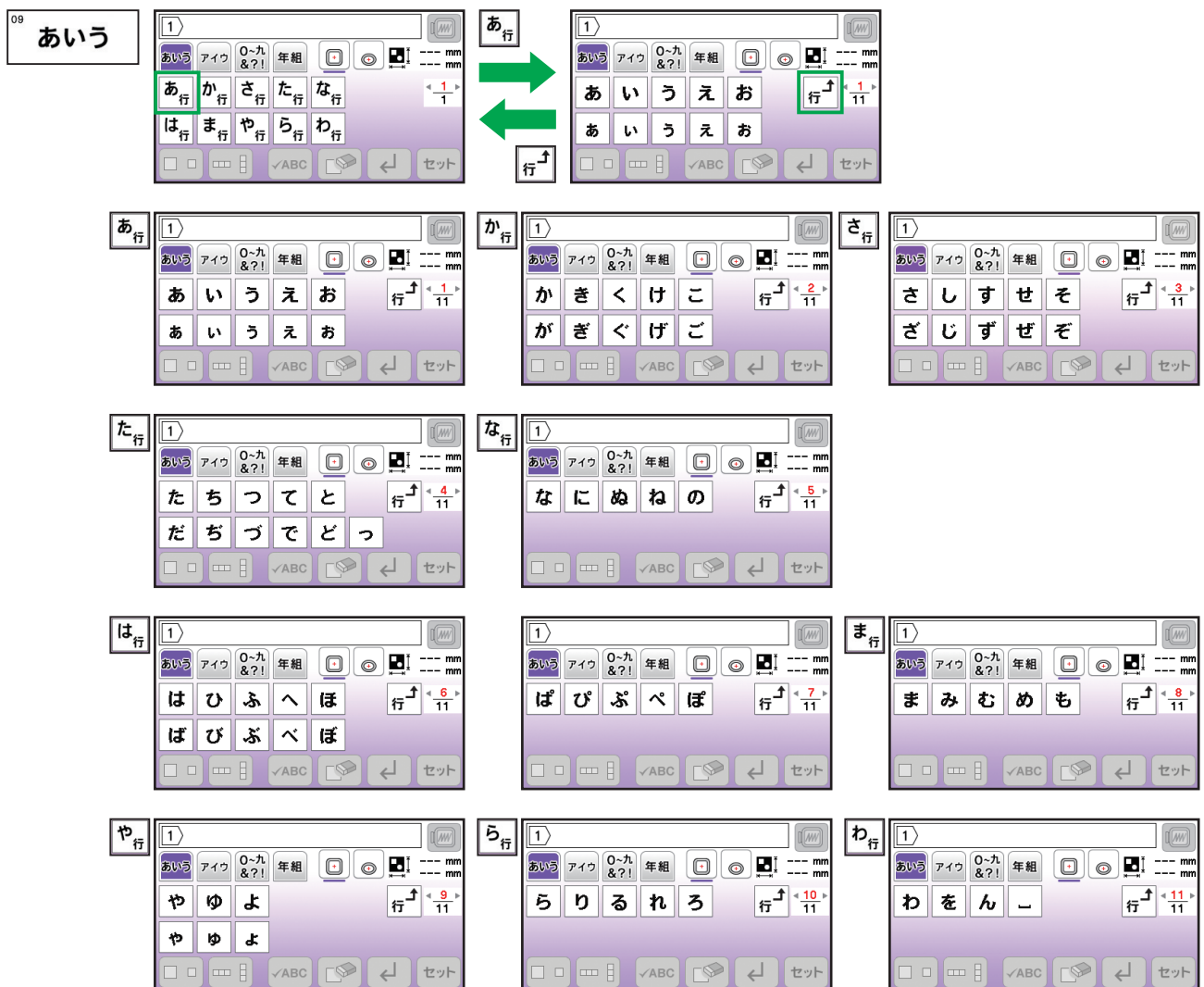
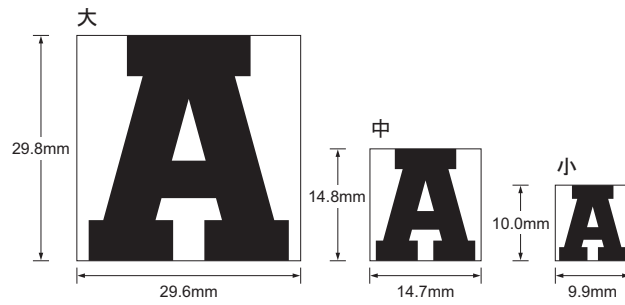

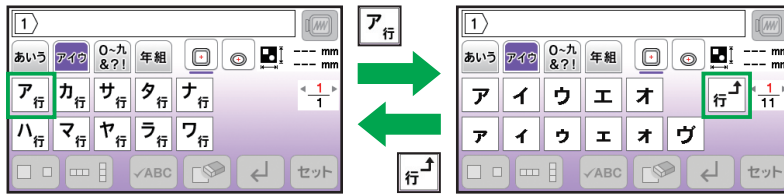

10 あいう

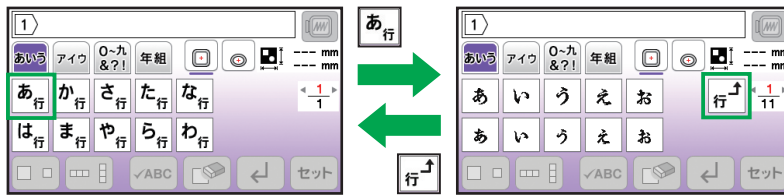

刺しゅう模様一覧

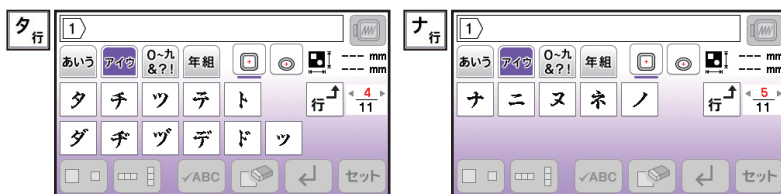
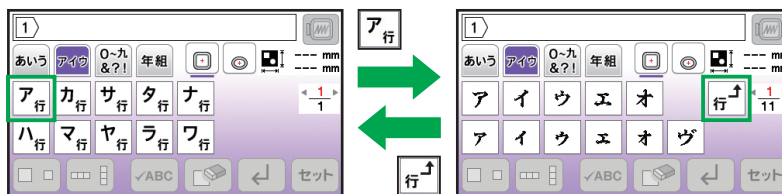
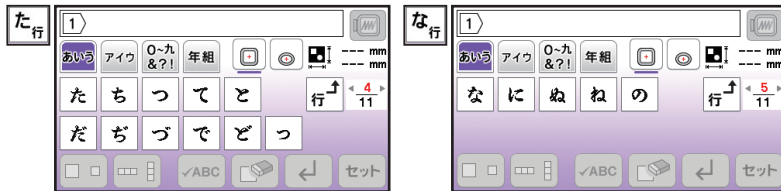

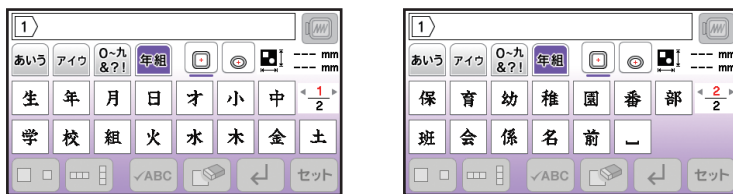
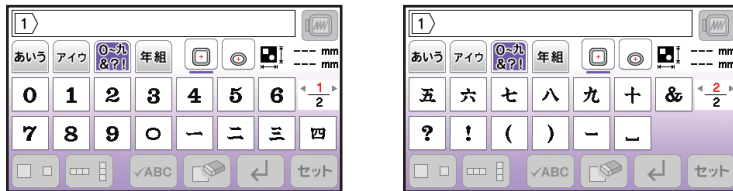

11 あいう

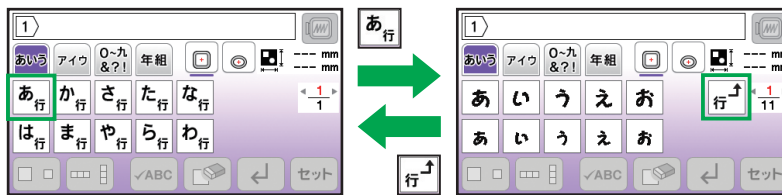

刺しゅう模様一覧

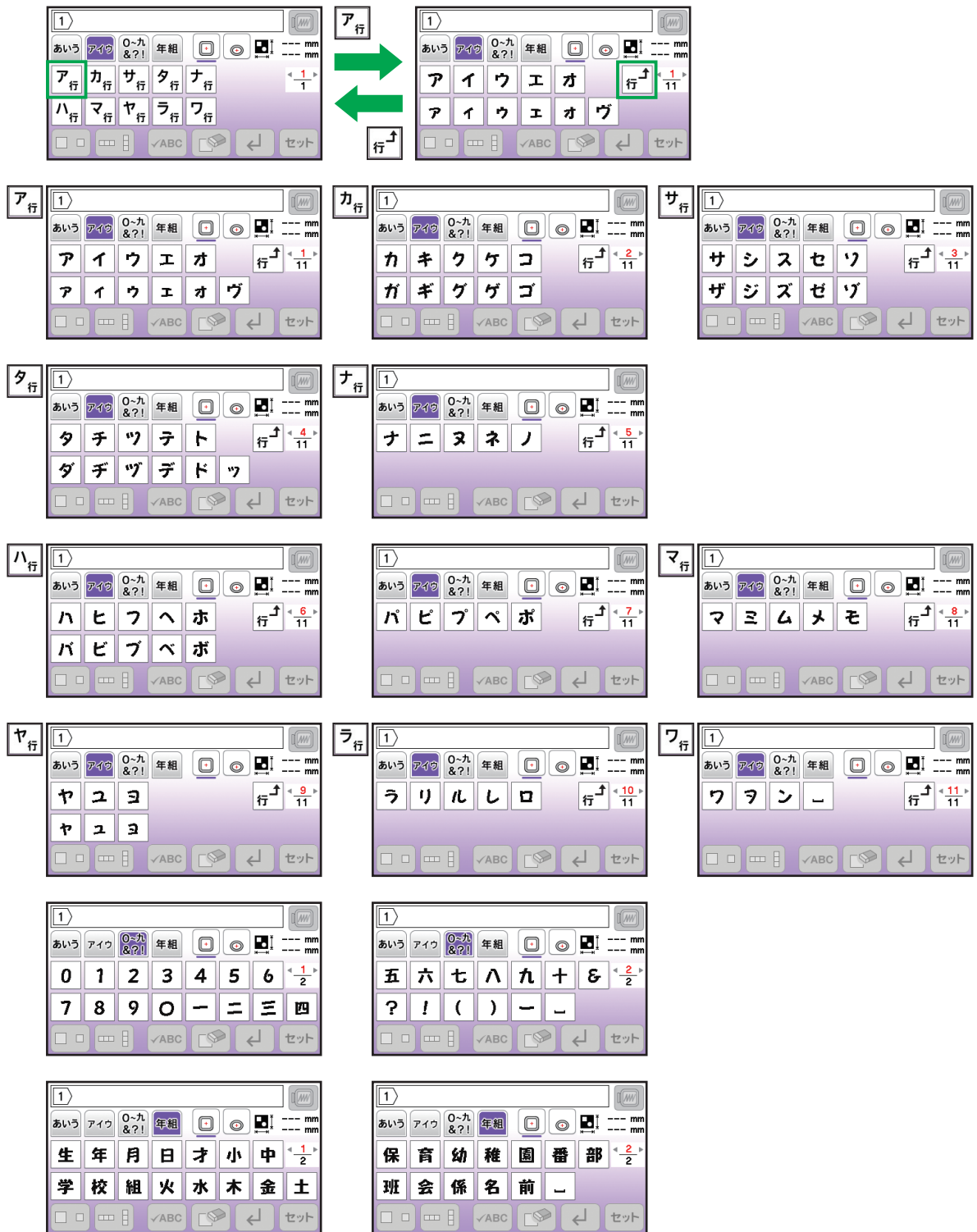

● 実寸例

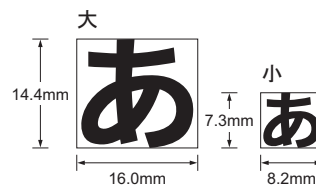

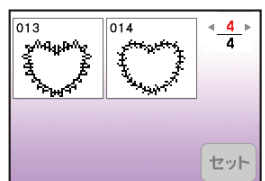
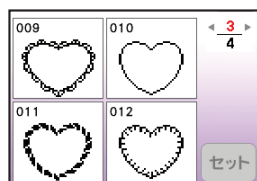
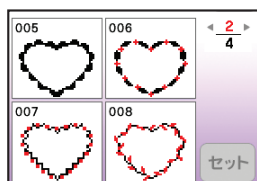
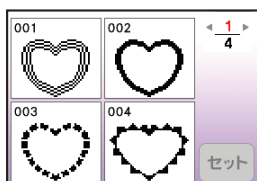
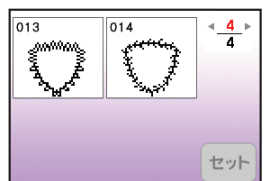
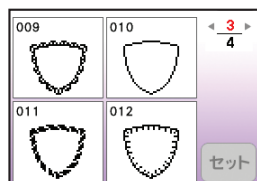
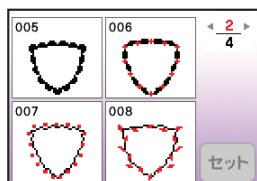
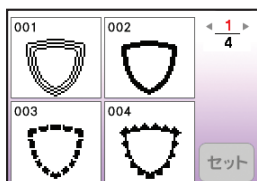
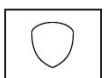
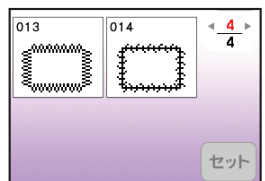
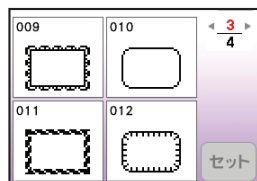
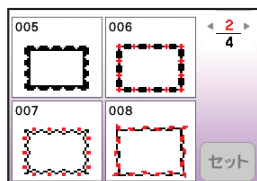
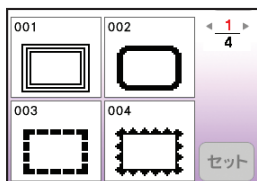
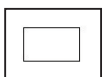
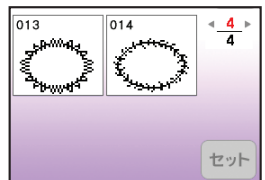
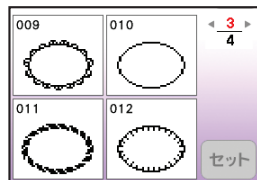
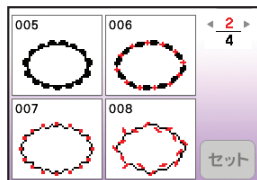
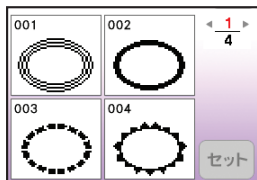
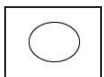
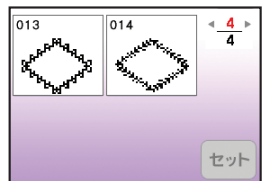
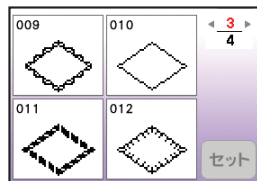
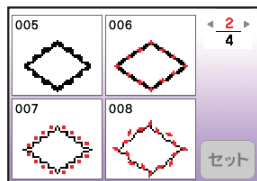
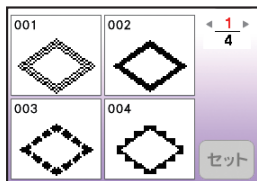
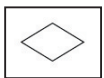
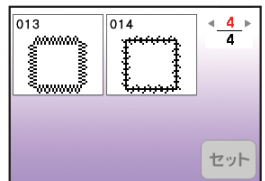
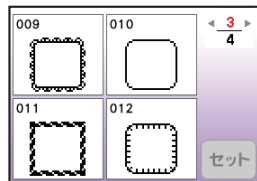
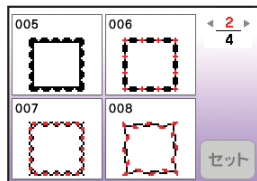
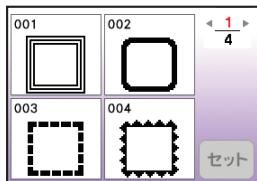
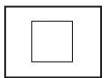
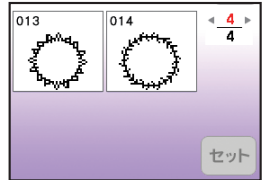
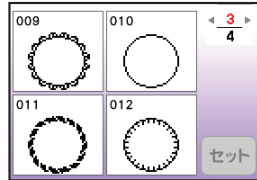
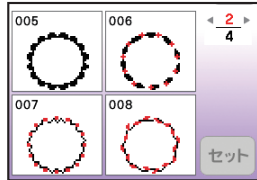
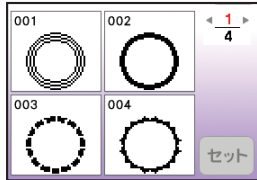
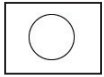
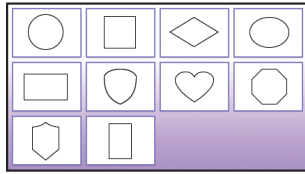
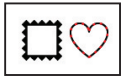

刺しゅう模様一覧

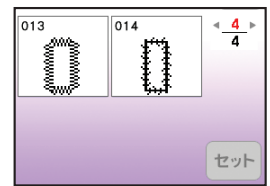
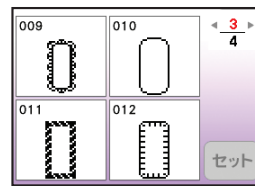
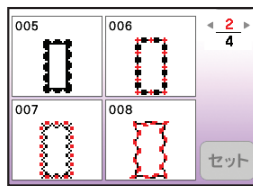
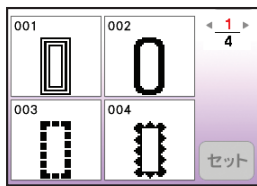
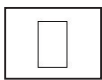
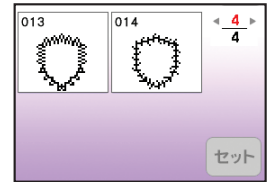
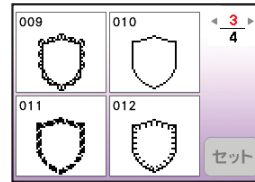
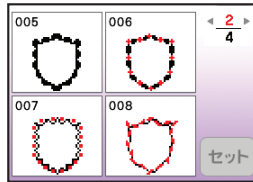
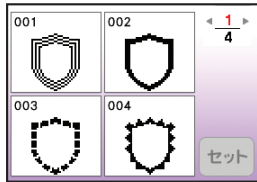
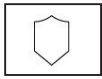
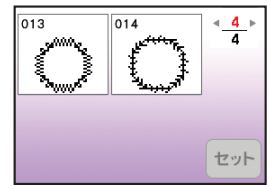
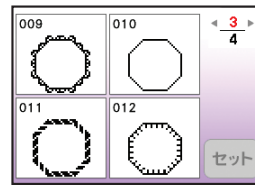
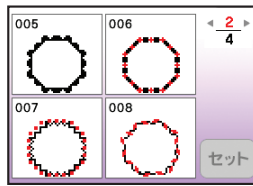
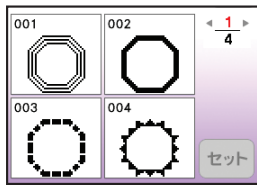
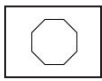

刺しゅう色替え表

- 模様によって推奨している刺しゅう糸が異なります。何も表記がない模様はブラザー刺しゅう糸（ウルトラポス）を推奨しています。カントリーと表記がある模様は、カントリー糸を推奨しています。推奨糸と異なる糸を使用する場合は、刺しゅう見本とは異なった仕上がりになることがあります。実際にぬう前に試しぬいを行って、色合いを確認してください。
- 刺しゅう糸については「色比較表」を参考にしてください。
- は、おおよその所要時間です。（糸替えの時間は含みません。）
- ミシンに内蔵された刺しゅうは、一般家庭用としてお楽しみ頂けるものであり、営業用、業務用としての使用は著作権法上固く禁じられております。

◆ワンポイント #1



No.1		21分	刺しゅう時間
ぬい番号	1	(607)	
	2	(010)	
	3	(005)	
	4	(086)	
	5	(534)	
	6	(843)	刺しゅう糸の番号
刺しゅう糸の色	7	(126)	
	8	(030)	
	↓	92.2 mm	大きさ
	↔	57.5 mm	



No.2		13分
1	(607)	
2	(502)	
3	(010)	
4	(005)	
5	(086)	
6	(843)	
7	(126)	
8	(030)	
↓	69.8 mm	
↔	65.9 mm	



No.5		3分
1	(005)	
2	(534)	
3	(126)	
4	(843)	
5	(030)	
6	(010)	
↓	46.0 mm	
↔	14.3 mm	



No.8		4分
1	(517)	
2	(406)	
3	(517)	
4	(807)	
↓	65.3 mm	
↔	67.8 mm	



No.3		5分
1	(534)	
2	(126)	
3	(005)	
4	(030)	
5	(502)	
↓	41.7 mm	
↔	86.2 mm	



No.6		4分
1	(005)	
2	(607)	
3	(843)	
↓	50.3 mm	
↔	20.6 mm	



No.9		4分
1	(517)	
2	(406)	
3	(517)	
4	(807)	
↓	28.8 mm	
↔	93.5 mm	



No.4		3分
1	(030)	
2	(126)	
3	(010)	
4	(502)	
5	(607)	
↓	27.6 mm	
↔	61.9 mm	



No.7		4分
1	(810)	
2	(005)	
3	(843)	
↓	34.5 mm	
↔	36.8 mm	



No.10		6分
1	(517)	
2	(406)	
3	(517)	
4	(807)	
↓	95.4 mm	
↔	76.6 mm	



No.11 **17分**



1	□ (001)
2	■ (502)
3	■ (017)
4	■ (019)
5	■ (704)

↓ 59.4 mm
↔ 59.7 mm

No.15 **9分**



1	-----x (001)
2	----- (001)
3	~~~~~ (001)
4	■ (019)
5	■ (406)
6	■ (019)
7	■ (337)

↓ 47.9 mm
↔ 47.6 mm

No.19 **18分**



1	■ (399)
---	---------

↓ 81.1 mm
↔ 68.0 mm

No.12 **14分**



1	□ (001)
2	■ (502)
3	■ (017)
4	■ (019)
5	■ (704)

↓ 29.0 mm
↔ 91.7 mm

No.16 **9分**



1	■ (017)
2	■ (406)
3	■ (337)

↓ 95.0 mm
↔ 17.4 mm

No.20 **10分**



1	■ (086)
---	---------

↓ 24.4 mm
↔ 77.2 mm

No.13 **21分**



1	□ (001)
2	■ (502)
3	■ (017)
4	■ (019)
5	■ (704)

↓ 68.4 mm
↔ 95.8 mm

No.17 **8分**



1	■ (017)
2	■ (406)
3	■ (337)

↓ 55.3 mm
↔ 55.3 mm

No.21 **1分**



1	■ (019)
2	■ (405)

↓ 12.5 mm
↔ 20.3 mm

No.14 **20分**



1	-----x (001)
2	----- (001)
3	~~~~~ (001)
4	■ (019)
5	■ (406)
6	■ (019)

↓ 94.6 mm
↔ 82.1 mm

No.18 **26分**



1	■ (323)
---	---------

↓ 95.4 mm
↔ 84.0 mm

No.22 **1分**



1	■ (810)
---	---------

↓ 11.2 mm
↔ 15.5 mm

No.23 **1分**



1	■ (214)
2	■ (206)
3	■ (070)
4	■ (323)

↓ 14.8 mm
↔ 14.7 mm

👉 印がついた模様を刺しゅう用水溶性シートに刺しゅうしてからシートを水で溶かすと、立体刺しゅうを作ることができます。

注意事項

- 上下同色の刺しゅう糸の使用をお勧めします。
- プラザー水溶性シートの使用をお勧めします。水溶性シートは乾燥しすぎるとやぶれやすくなりますので、取り扱いに注意してください。
- 水溶性シートは3枚重ねて使用してください。
- 模様を刺しゅう枠の中心に配置して、刺しゅうしてください。
- 模様を刺しゅうするために十分な上糸、下糸があることを確認してから刺しゅうしてください。途中で糸がなくなったときは、10針以上戻って重ねて刺しゅうしてください。
- 水溶性シートを溶かすときは、不要な部分を切り取り、ぬめりがなくなるまでぬるま湯で洗ってください。その後、半乾きの状態で形を整えてからあて布ではさみ、アイロンで押さえながら形を整えてください。

👉 アプリケの作り方については、ミシンの取扱説明書を参照してください。



No.24		8 分
1		(017)
2		(124)
3		(202)
4		(206)
5		(005)
6		(001)
↓		32.6 mm
↔		75.7 mm



No.29		8 分
1		(001)
2		(017)
3		(502)
4		(086)
5		(202)
6		(019)
7		(126)
8		(612)
9		(800)
10		(086)
11		(001)
↓		63.0 mm
↔		29.7 mm



No.33		18 分
1		(507)
2		(328)
3		(001)
4		(800)
5		(328)
↓		52.8 mm
↔		98.5 mm



No.25		18 分
1	---	(017)
2	---	(085)
3	---	(017)
4	---	(017)
5		(017)
6	---	(085)
7	---	(085)
8		(001)
9		(085)
10		(800)
↓		95.6 mm
↔		77.1 mm



No.30		16 分
1		(030)
2		(019)
3		(001)
4		(405)
5		(005)
6		(017)
7		(019)
8		(206)
9		(001)
10		(405)
11		(030)
12		(017)
↓		48.4 mm
↔		91.4 mm



No.34		18 分
1		(406)
2		(507)
3		(513)
4		(205)
5		(513)
6		(612)
7		(019)
8		(001)
9		(086)
10		(328)
11		(800)
12		(205)
↓		56.1 mm
↔		71.7 mm



No.26		19 分
1		(124)
2		(001)
3		(086)
4		(001)
5		(017)
6		(612)
7		(085)
8		(205)
9		(019)
10		(900)
↓		67.2 mm
↔		66.3 mm



No.31		19 分
1		(214)
2		(323)
3		(339)
4		(030)
5		(515)
6		(513)
7		(209)
8		(208)
9		(612)
10		(620)
11		(339)
↓		52.8 mm
↔		69.3 mm



No.35		18 分
1		(214)
2		(800)
↓		96.2 mm
↔		61.3 mm



No.27		8 分
1		(807)
2		(515)
3		(001)
4		(017)
5		(070)
↓		61.6 mm
↔		76.9 mm



No.28		11 分
1		(001)
2		(005)
3		(405)
4		(800)
5		(001)
6		(817)
↓		50.2 mm
↔		50.2 mm



No.32		11 分
1		(010)
2		(027)
3		(001)
4		(620)
5		(205)
6		(900)
7		(030)
8		(339)
9		(405)
10		(030)
↓		60.6 mm
↔		68.2 mm

◆ワンポイント #2



No.1 15分

1	(804)
2	(017)
3	(502)
4	(812)
5	(126)
6	(086)

↓ 57.1 mm
↔ 95.2 mm

No.5 33分

1	(542)
2	(810)
3	(542)
4	(415)
5	(810)
6	(085)
7	(307)
8	(812)
9	(010)
10	(001)

↓ 87.5 mm
↔ 91.7 mm

No.8 11分

1	(030)
---	-------

↓ 93.8 mm
↔ 94.5 mm

No.2 20分

1	(502)
2	(085)
3	(017)
4	(001)
5	(812)
6	(086)
7	(001)
8	(804)

↓ 92.7 mm
↔ 93.9 mm

No.6 13分

1	(542)
2	(812)
3	(010)
4	(810)
5	(415)
6	(810)
7	(124)
8	(001)

↓ 73.3 mm
↔ 92.0 mm

No.9 47分

1	(001)
2	(328)
3	(001)
4	(800)

↓ 93.6 mm
↔ 93.5 mm

No.3 11分

1	(817)
2	(812)
3	(502)
4	(085)
5	(001)
6	(086)
7	(804)
8	(085)

↓ 93.8 mm
↔ 54.7 mm

No.7 20分

1	(542)
2	(810)
3	(804)
4	(607)
5	(070)

↓ 90.7 mm
↔ 94.3 mm

No.10 25分

1	(420)
2	(001)
3	(420)
4	(900)

↓ 73.1 mm
↔ 58.4 mm

No.4 10分

1	(812)
2	(085)
3	(086)
4	(502)
5	(804)

↓ 84.7 mm
↔ 89.5 mm

No.11 14分

1	(328)
2	(323)
3	(517)

↓ 83.8 mm
↔ 77.3 mm

🧺 印がついた模様を刺しゅう用水溶性シートに刺しゅうしてからシートを水で溶かすと、立体刺しゅうを作ることができます。

注意事項

- 上下同色の刺しゅう糸の使用をお勧めします。
- ブラザー水溶性シートの使用をお勧めします。水溶性シートは乾燥しすぎるとやぶれやすくなりますので、取り扱いに注意してください。
- 水溶性シートは3枚重ねて使用してください。
- 模様を刺しゅう枠の中心に配置して、刺しゅうしてください。
- 模様を刺しゅうするために十分な上糸、下糸があることを確認してから刺しゅうしてください。途中で糸がなくなったときは、10針以上戻って重ねて刺しゅうしてください。
- 水溶性シートを溶かすときは、不要な部分を切り取り、ぬめりがなくなるまでぬるま湯で洗ってください。その後、半乾きの状態で形を整えてからあて布ではさみ、アイロンで押さえながら形を整えてください。

🧡 アプリケの作り方については、ミシンの取扱説明書を参照してください。



No.12 **4分**

1	■ (214)
↓	30.6 mm
↔	49.4 mm



No.17 **23分**

1	---× (086)
2	--- (086)
3	~~~~ (086)
4	■ (086)
5	~~~~ (086)
6	■ (086)
7	■ (007)
8	□ (001)
9	■ (085)
10	■ (030)
↓	84.0 mm
↔	95.9 mm



No.20 **13分**

1	---× (085)
2	--- (085)
3	~~~~ (085)
4	--- (542)
5	--- (542)
6	~~~~ (542)
7	□ (001)
8	■ (542)
↓	69.7 mm
↔	95.0 mm



No.13 **7分**

1	■ (399)
2	■ (206)
↓	88.5 mm
↔	73.2 mm



No.18 **28分**

1	---× (010)
2	--- (010)
3	--- (010)
4	---× (001)
5	--- (001)
6	~~~~ (001)
7	■ (900)
8	■ (502)
9	■ (509)
↓	95.8 mm
↔	90.2 mm



No.21 **13分**

1	---× (542)
2	--- (542)
3	~~~~ (542)
4	---× (399)
5	--- (399)
6	~~~~ (399)
7	■ (542)
8	■ (214)
9	■ (205)
10	■ (542)
11	■ (399)
↓	94.1 mm
↔	80.4 mm

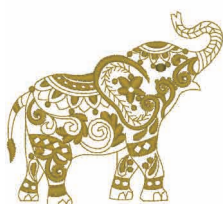

No.14 **14分**

1	■ (328)
2	■ (330)
↓	85.5 mm
↔	94.8 mm

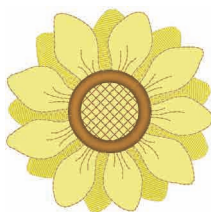

No.19 **25分**

1	■ (208)
2	---× (206)
3	■ (206)
4	■ (208)
5	~~~~ (323)
6	■ (323)
↓	88.9 mm
↔	90.5 mm

① ...A ×

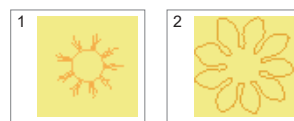

② ...B

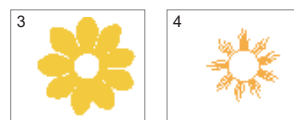

③

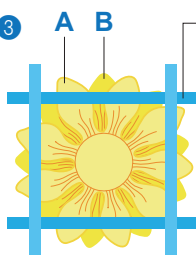

仮どめ
テープ

④ ...C

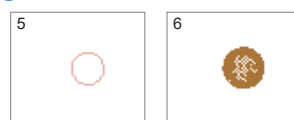

No.15 **12分**

1	■ (206)
2	■ (502)
3	■ (017)
4	■ (019)
5	■ (086)
6	■ (420)
↓	91.9 mm
↔	82.1 mm

A 推奨する布地：フェルト

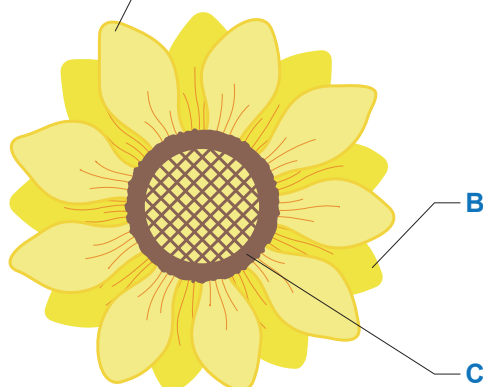

No.16 **23分**

1	■ (620)
2	■ (534)
3	■ (612)
4	■ (079)
5	■ (804)
6	■ (620)
7	■ (328)
↓	76.7 mm
↔	81.8 mm



刺しゅう色替え表

No.22 **17分**

1	-----× (817)	*
2	----- (817)	
3	~~~~~ (817)	
4	■ (817)	*
5	-----× (070)	
6	----- (070)	
7	~~~~~ (070)	
8	■ (070)	
9	■ (843)	
10	■ (001)	
11	■ (085)	
12	■ (817)	
13	■ (086)	
14	■ (070)	
↓	91.2 mm	
↔	90.2 mm	

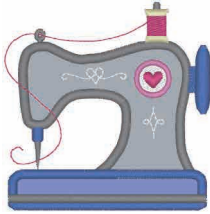

No.25 **10分**

1	-----× (085)	*
2	----- (085)	
3	~~~~~ (085)	
4	-----× (017)	*
5	----- (017)	
6	~~~~~ (017)	
7	-----× (214)	*
8	----- (214)	
9	~~~~~ (214)	
10	■ (214)	
11	■ (017)	
12	■ (085)	
13	■ (086)	
14	■ (205)	
15	■ (001)	
16	■ (017)	
17	■ (513)	
↓	81.3 mm	
↔	61.9 mm	



No.23 **16分**

1	-----× (019)	*
2	----- (019)	
3	~~~~~ (019)	
4	-----× (420)	*
5	----- (420)	
6	~~~~~ (420)	
7	■ (019)	
8	■ (420)	
9	■ (399)	
10	■ (030)	
11	■ (205)	
↓	63.8 mm	
↔	95.7 mm	



No.24 **18分**

1	-----× (800)	*
2	----- (800)	
3	~~~~~ (800)	
4	-----× (005)	*
5	----- (005)	
6	~~~~~ (005)	
7	■ (205)	
8	■ (126)	
9	■ (005)	
10	■ (800)	
11	■ (019)	
12	■ (817)	
↓	91.3 mm	
↔	78.1 mm	

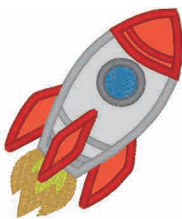

② この印が付いたアップリケ模様では、最初から最後まで土台の布地を刺しゅう枠に張った状態で刺しゅうしてください。

* ①

②

仮どめ

③

④

♥ アップリケの作り方については、ミシンの取扱説明書を参照してください。

◆バラエティ



No.1 38分



1	□ (001)
2	□ (124)
3	■ (704)
4	□ (001)
5	□ (124)
6	■ (214)
7	■ (509)
8	■ (704)
9	■ (502)
10	■ (509)
11	■ (079)
12	■ (085)
↓	93.4 mm
↔	92.7 mm

No.4 41分



1	□ (001)
2	□ (124)
3	■ (017)
4	■ (206)
5	■ (804)
6	■ (704)
7	■ (502)
8	■ (534)
9	□ (001)
10	□ (124)
11	■ (017)
12	■ (019)
13	■ (206)
14	■ (704)
↓	95.1 mm
↔	74.9 mm

No.7 42分



1	□ (001)
2	□ (001)
3	■ (001)
4	■ (085)
5	□ (001)
6	■ (017)
7	■ (704)
8	□ (001)
9	■ (010)
10	■ (017)
11	■ (542)
12	□ (124)
13	■ (085)
14	■ (502)
15	■ (704)
↓	93.1 mm
↔	91.9 mm



No.2 42分



1	□ (001)
2	■ (005)
3	■ (019)
4	□ (079)
5	■ (704)
6	□ (001)
7	■ (399)
8	■ (005)
9	■ (817)
10	■ (030)
11	■ (800)
12	□ (001)
13	■ (704)
14	■ (707)
↓	95.5 mm
↔	77.6 mm

No.5 41分



1	□ (001)
2	■ (812)
3	■ (704)
4	■ (502)
5	■ (513)
6	□ (001)
7	■ (804)
8	■ (812)
9	■ (607)
10	■ (612)
11	□ (124)
12	■ (704)
↓	94.3 mm
↔	91.6 mm

No.8 37分



1	□ (001)
2	■ (502)
3	■ (810)
4	■ (804)
5	■ (704)
6	□ (001)
7	■ (810)
8	■ (704)
9	■ (348)
10	■ (206)
11	■ (126)
12	■ (209)
13	■ (502)
14	■ (704)
↓	80.1 mm
↔	93.2 mm

No.3 38分



1	□ (001)
2	□ (001)
3	■ (001)
4	□ (001)
5	□ (124)
6	■ (202)
7	■ (017)
8	■ (704)
9	■ (502)
10	■ (804)
11	□ (001)
12	■ (202)
13	■ (704)
↓	94.5 mm
↔	83.3 mm



No.6 42分



1	□ (001)
2	□ (124)
3	■ (017)
4	■ (704)
5	■ (502)
6	■ (513)
7	□ (001)
8	■ (017)
9	□ (124)
10	■ (085)
11	■ (010)
12	■ (704)
↓	78.8 mm
↔	95.7 mm

No.9 19分

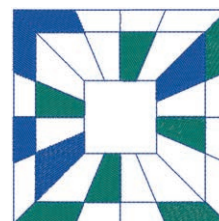

1	■ (534)
2	■ (420)
↓	94.6 mm
↔	94.7 mm

No.10

6分	
1	■ (534)
2	■ (420)
↕	94.5 mm
↔	31.6 mm



No.13

8分	
1	---× (206)
2	---× (209)
3	■ (005)
4	--- (206)
5	--- (206)
6	--- (209)
7	--- (209)
↕	95.9 mm
↔	95.8 mm



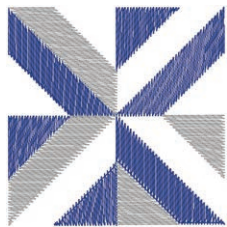

No.11

10分	
1	■ (406)
2	■ (005)
↕	95.5 mm
↔	95.5 mm



No.14

4分	
1	■ (030)
↕	95.0 mm
↔	95.0 mm



No.12

6分	
1	■ (406)
2	■ (005)
↕	95.0 mm
↔	25.0 mm



No.15

3分	
1	■ (030)
↕	94.3 mm
↔	95.5 mm



◆モノグラム



No.1 4分

1	(000)
2	(461)
3	(442)

↓ 38.5 mm
⇔ 45.5 mm

カントリー

No.7 4分

1	(000)
2	(461)
3	(442)

↓ 38.4 mm
⇔ 35.4 mm

カントリー

No.13 4分

1	(000)
2	(461)
3	(442)

↓ 38.2 mm
⇔ 59.3 mm

カントリー

No.2 4分

1	(000)
2	(331)
3	(334)

↓ 38.7 mm
⇔ 41.8 mm

カントリー

No.8 5分

1	(000)
2	(334)

↓ 38.0 mm
⇔ 43.5 mm

カントリー

No.14 3分

1	(000)
2	(331)
3	(334)

↓ 36.4 mm
⇔ 52.9 mm

カントリー

No.3 4分

1	(000)
2	(020)
3	(012)

↓ 39.1 mm
⇔ 37.4 mm

カントリー

No.9 2分

1	(000)
2	(020)
3	(012)

↓ 37.5 mm
⇔ 33.0 mm

カントリー

No.15 3分

1	(000)
2	(020)
3	(012)

↓ 37.8 mm
⇔ 31.3 mm

カントリー

No.4 4分

1	(000)
2	(512)
3	(003)

↓ 38.8 mm
⇔ 40.0 mm

カントリー

No.10 3分

1	(000)
2	(512)
3	(003)

↓ 43.4 mm
⇔ 36.6 mm

カントリー

No.16 3分

1	(000)
2	(003)

↓ 37.7 mm
⇔ 40.3 mm

カントリー

No.5 3分

1	(000)
2	(604)
3	(623)

↓ 37.5 mm
⇔ 32.1 mm

カントリー

No.11 4分

1	(000)
2	(604)
3	(623)

↓ 37.7 mm
⇔ 50.9 mm

カントリー

No.17 4分

1	(000)
2	(604)
3	(623)

↓ 37.4 mm
⇔ 30.1 mm

カントリー

No.6 4分

1	(000)
2	(152)
3	(155)

↓ 37.6 mm
⇔ 34.2 mm

カントリー

No.12 4分

1	(000)
2	(152)
3	(155)

↓ 37.7 mm
⇔ 43.6 mm

カントリー

No.18 4分

1	(000)
2	(152)
3	(155)

↓ 37.1 mm
⇔ 46.9 mm

カントリー

刺しゅう色替え表

No.19 **3分**

1	(000)
2	(461)
3	(442)

↓ 37.2 mm
↔ 33.3 mm

カントリー 



No.26 **3分**

1	(000)
2	(334)
3	(331)

↓ 37.6 mm
↔ 36.7 mm

カントリー 



No.20 **3分**

1	(000)
2	(331)
3	(334)

↓ 37.0 mm
↔ 42.6 mm

カントリー 



No.27 **17分**

1	(000)
2	(370)
3	(335)

↓ 71.7 mm
↔ 93.1 mm

カントリー 



No.21 **4分**

1	(000)
2	(012)
3	(020)

↓ 38.2 mm
↔ 40.7 mm

カントリー 



No.28 **19分**

1	(000)
2	(003)
3	(604)

↓ 72.3 mm
↔ 94.6 mm

カントリー 



No.22 **4分**

1	(000)
2	(512)
3	(003)

↓ 38.2 mm
↔ 46.9 mm

カントリー 



No.29 **12分**

1	(000)
2	(623)
3	(604)

↓ 68.0 mm
↔ 93.5 mm

カントリー 



No.23 **5分**

1	(000)
2	(512)
3	(623)

↓ 37.4 mm
↔ 49.6 mm

カントリー 



No.30 **14分**

1	(000)
2	(442)
3	(025)

↓ 66.5 mm
↔ 92.4 mm

カントリー 



No.24 **4分**

1	(000)
2	(152)
3	(155)

↓ 38.9 mm
↔ 52.6 mm

カントリー 



No.25 **4分**

1	(000)
2	(442)
3	(461)

↓ 38.0 mm
↔ 42.7 mm

カントリー 



◆花アルファベット



No.1

7分
1 (007)
2 (804)
↓ 54.3 mm
↔ 82.8 mm

No.6

6分
1 (007)
2 (804)
↓ 54.0 mm
↔ 78.8 mm

No.11

7分
1 (007)
2 (804)
↓ 55.2 mm
↔ 85.3 mm

No.2

7分
1 (007)
2 (804)
↓ 54.4 mm
↔ 72.6 mm

No.7

6分
1 (007)
2 (804)
↓ 54.6 mm
↔ 70.4 mm

No.12

6分
1 (007)
2 (804)
↓ 53.9 mm
↔ 75.0 mm

No.3

6分
1 (007)
2 (804)
↓ 53.9 mm
↔ 73.3 mm

No.8

8分
1 (007)
2 (804)
↓ 54.3 mm
↔ 83.3 mm

No.13

7分
1 (007)
2 (804)
↓ 54.1 mm
↔ 85.0 mm

No.4

7分
1 (007)
2 (804)
↓ 54.6 mm
↔ 80.0 mm

No.9

5分
1 (007)
2 (804)
↓ 55.0 mm
↔ 68.3 mm

No.14

7分
1 (007)
2 (804)
↓ 54.6 mm
↔ 84.8 mm

No.5

6分
1 (007)
2 (804)
↓ 55.0 mm
↔ 65.3 mm













No.10

6分
1 (007)
2 (804)
↓ 54.3 mm
↔ 71.0 mm

No.15

5分
1 (007)
2 (804)
↓ 53.9 mm
↔ 78.7 mm

刺しゅう色替え表

<p>No.16</p> 	<p>6分</p> <p>1 ■ (007)</p> <p>2 ■ (804)</p> <p>⇕ 54.7 mm</p> <p>⇔ 67.2 mm</p>	<p>No.22</p> 	<p>5分</p> <p>1 ■ (007)</p> <p>2 ■ (804)</p> <p>⇕ 53.2 mm</p> <p>⇔ 70.9 mm</p>	<p>No.28</p> 	<p>4分</p> <p>1 ■ (007)</p> <p>2 ■ (804)</p> <p>⇕ 51.3 mm</p> <p>⇔ 47.0 mm</p>
<p>No.17</p> 	<p>6分</p> <p>1 ■ (007)</p> <p>2 ■ (804)</p> <p>⇕ 54.9 mm</p> <p>⇔ 83.5 mm</p>	<p>No.23</p> 	<p>8分</p> <p>1 ■ (007)</p> <p>2 ■ (804)</p> <p>⇕ 53.4 mm</p> <p>⇔ 82.6 mm</p>	<p>No.29</p> 	<p>2分</p> <p>1 ■ (007)</p> <p>2 ■ (804)</p> <p>⇕ 13.3 mm</p> <p>⇔ 65.2 mm</p>
<p>No.18</p> 	<p>7分</p> <p>1 ■ (007)</p> <p>2 ■ (804)</p> <p>⇕ 54.7 mm</p> <p>⇔ 81.5 mm</p>	<p>No.24</p> 	<p>7分</p> <p>1 ■ (007)</p> <p>2 ■ (804)</p> <p>⇕ 53.2 mm</p> <p>⇔ 83.4 mm</p>	<p>No.30</p> 	<p>5分</p> <p>1 ■ (007)</p> <p>2 ■ (804)</p> <p>⇕ 25.3 mm</p> <p>⇔ 95.9 mm</p>
<p>No.19</p> 	<p>6分</p> <p>1 ■ (007)</p> <p>2 ■ (804)</p> <p>⇕ 54.5 mm</p> <p>⇔ 73.8 mm</p>	<p>No.25</p> 	<p>6分</p> <p>1 ■ (007)</p> <p>2 ■ (804)</p> <p>⇕ 53.1 mm</p> <p>⇔ 65.9 mm</p>		
<p>No.20</p> 	<p>6分</p> <p>1 ■ (007)</p> <p>2 ■ (804)</p> <p>⇕ 54.2 mm</p> <p>⇔ 73.2 mm</p>	<p>No.26</p> 	<p>7分</p> <p>1 ■ (007)</p> <p>2 ■ (804)</p> <p>⇕ 55.9 mm</p> <p>⇔ 70.0 mm</p>		
<p>No.21</p> 	<p>6分</p> <p>1 ■ (007)</p> <p>2 ■ (804)</p> <p>⇕ 53.6 mm</p> <p>⇔ 78.3 mm</p>	<p>No.27</p> 	<p>6分</p> <p>1 ■ (007)</p> <p>2 ■ (804)</p> <p>⇕ 57.4 mm</p> <p>⇔ 57.7 mm</p>		

刺しゅうアレンジ例

- 模様を組み合わせる

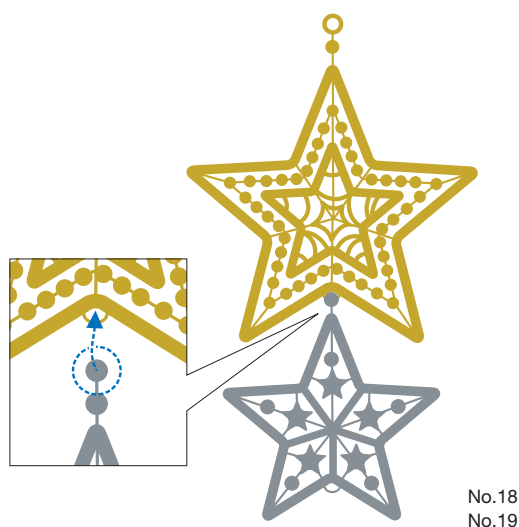

No.18
No.19



No.20



No.1
No.30



No.3
No.4 x 2



No.7 x 3







No.8 x 4









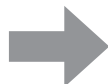





































































No.5
No.6 x 2

No.10

- 1  (420) ★
- 2  (001)
- 3  (420) ★
- 4  (900)



色比較表

	糸色名	Embroidery (ブラザー刺しゅう糸 (ウルトラポス))	Country (ブラザー刺しゅう糸 (カントリー))	Madeira Poly (マデイラ ポリエステル)	Madeira Rayon (マデイラ レーヨン)	Sulky (サルキー)	Robison-Anton (ロビソン・ アントン)
1	クロ	 900	 100	1800	1000	1005	5596
2	シロ	 001	 000	1801	1002	1001	5597
3	アカ	 800	 149	1637	1037	1037	5678
4	ピンク	 085	 155	1921	1108	1224	5523
5	コイピンク	 086	 024	1721	1117	1154	9168
6	モモイロ	 124	 152	1915	1015	1064	5677
7	マゼンダ	 107	 126	1984	1383	1533	5804
8	シュイロ	 030	 148	1779	1179	1184	9023
9	ベニイロ	 807	 158	1986	1081	1511	5561
10	コイアカムラサキ	 869	 636	1788	1188	1192	5681
11	アカムラサキ	 620	 625	1710	1319	1191	5592
12	サーモンピンク	 079	 122	1816	1317	1225	5773
13	ベニカバイロ	 333	 212	1942	1341	1119	5591
14	レモンイロ	 202	 342	1623	1023	1067	5625
15	キイロ	 205	 043	1980	1068	1187	5860
16	ヤマブキイロ	 206	 334	1971	1024	1124	5770
17	オレンジ	 208	 335	1951	1137	1024	5694
18	ダイダイイロ	 126	 322	1952	1155	1065	5630
19	マンダリン	 209	 336	1965	1078	1078	5518
20	クリームイロ	 010	 331	1866	1022	1061	5761
21	タマゴイロ	 812	 370	1861	1349	1135	5564
22	ツチイロ	 348	 242	1939	1255	1055	5636
23	オウドイロ	 214	 354	1772	1172	1025	5770
24	キンチャ	 328	 404	1791	1192	1159	9109
25	ハダイロ	 307	 025	1682	1149	1082	5635
26	コイコゲチャ	 058	 717	1859	1130	1129	5637
27	アカチャイロ	 337	 264	1753	1253	1021	5781
28	チャ	 339	 224	1621	1021	1158	5590
29	ページュ	 843	 012	1738	1138	1127	5598
30	ハイイロ	 399	 706	1860	1085	1218	9126
31	クチバイロ	 330	 414	1726	1194	1126	5702
32	コゲチャ	 323	 255	1729	1056	1128	5789
33	セイジイロ	 542	 505	1647	1219	1077	5578
34	エメラルドグリーン	 502	 461	1702	1302	1047	5511
35	トキワイロ	 509	 463	1749	1050	1510	5514
36	マツバイロ	 519	 476	1904	1396	1174	5502
37	ハイミドリ	 517	 473	1769	1156	1156	9122
38	アオミドリ	 534	 483	1879	1298	1503	5751

	糸色名	Embroidery (ブラザー刺しゅう糸 (ウルトラポス))	Country (ブラザー刺しゅう糸 (カントリー))	Madeira Poly (マデイラ ポリエステル)	Madeira Rayon (マデイラ レーヨン)	Sulky (サルキー)	Robison-Anton (ロビソン・ アントン)
39	ミドリ	 507	 485	1750	1250	1079	5508
40	フカミドリ	 808	 467	1703	1370	1208	5615
41	ワカバイロ	 027	 442	1706	1102	1209	9153
42	キミドリ	 513	 444	1848	1049	1177	5622
43	モスグリーン	 515	 446	1770	1369	1176	9091
44	アオ	 405	 586	1829	1177	1076	5684
45	グンジョウイロ	 406	 575	1842	1076	1042	5736
46	ミズイロ	 017	 150	1932	1132	1074	5683
47	ソライロ	 019	 512	1828	1029	1196	5506
48	ライトブルー	 420	 564	1797	1297	1250	5829
49	ナンドイロ	 415	 057	1652	1252	1206	5810
50	アイイロ	 007	 588	1767	1166	1535	5737
51	アオムラサキ	 070	 015	1830	1335	1028	5601
52	ウスアカムラサキ	 810	 133	1911	1031	1121	9016
53	ウスムラサキ	 612	 623	1831	1080	1080	9009
54	スマileyロ	 613	 624	1631	1033	1194	5588
55	ムラサキ	 614	 635	1880	1122	1122	5554
56	フジイロ	 804	 604	1630	1261	1193	5586
57	フジムラサキ	 607	 003	1943	1311	1032	5587
58	グレー	 704	 745	1840	1041	1041	9114
59	コイグレー	 707	 747	1841	1241	1220	5565
60	ギン	 005	 020	1812	1087	1011	5640
61	ネズミイロ	 817	 734	1640	1118	1219	5782
62	アプリケピース	-----✂					
63	アプリケノイチ	-----					
64	アプリケ	~~~~~ TTTTTTTTTTTTTTTTTTTTTTTTTT					

注意

- 上記の表は、ブラザー刺しゅう糸(ウルトラポス)を基準にして、他のブランドの一番近い糸色番号と対応させた色比較表です。ブランドごとで多少仕上がりの色味が異なる場合がありますので、実際にぬう前に、試しぬいを行って色合いを確認してください。
- Madeira, Sulky, Robison-Antonは、それぞれ各社の登録商標です。
- 比較表の糸色は実際の色と異なることがあります。

フォント名一覧

	フォントキー	フォント名
1	⁰¹ ABC	Block 01
2	⁰² ABC	Serif 01
3	⁰³ ABC	Brussels Demi Outline
4	⁰⁴ ABC	Calgary MediumItalic
5	⁰⁵ ABC	Sicilia Light Italic
6	⁰⁶ ABC	Istanbul
7	⁰⁷ ABC	Los Angeles
8	⁰⁸ ABC	Tennessee ExtraBold
9	⁰⁹ あいう	日本語 1
10	¹⁰ あいう	日本語 2
11	¹¹ あいう	日本語 3

888-P08/P09



D029JG-101①