

brother

業務用刺しゅうミシン

模様一覧

PRT52シリーズ



お知らせ

- ご使用前に、取扱説明書内の各種刺しゅう模様の利用規約をお読みください。
- 最初に取扱説明書の「安全にお使いいただくために」を必ずお読みください。
- 詳しい手順については、取扱説明書を参照してください。
- 画面および仕様は、改良のため予告なく変更することがあります。

目次

刺しゅう模様一覧	2
刺しゅう色替え表	18
模様組み合わせ例	46
3D 刺しゅうの作り方	48
フォント名一覧	49

刺しゅう模様一覧

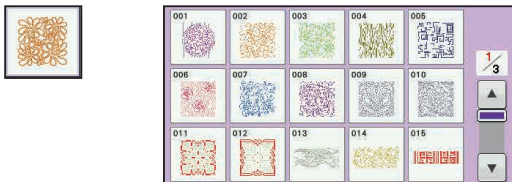
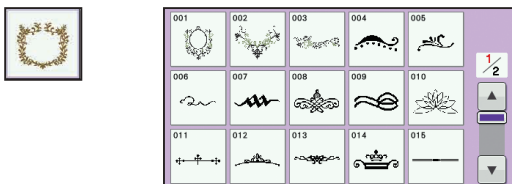
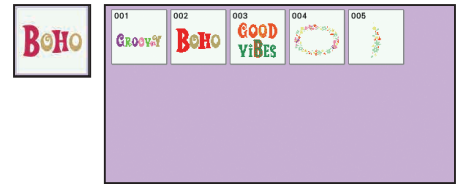
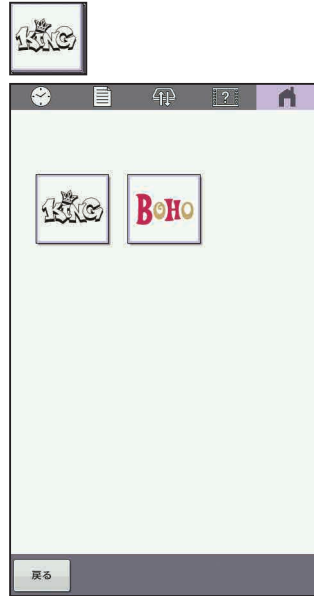
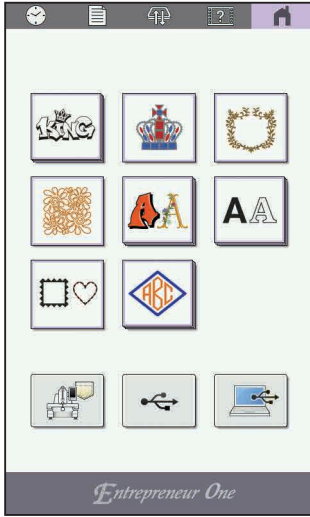



AB	12	AB
AB	AB	A.B.
AB	AA	



001	002	003	004	005	1/2
A	B	C	D	E	
006	007	008	009	010	
F	G	H	I	J	▲
011	012	013	014	015	
K	L	M	N	O	▼

016	017	018	019	020	2/2
P	Q	R	S	T	
021	022	023	024	025	
U	V	W	X	Y	▲
026					



001	002	003	004	005	1/2
0	1	2	3	4	
006	007	008	009	010	
5	6	7	8	9	▲



001	002	003	004	005	1/2
A	B	C	D	E	
006	007	008	009	010	
F	G	H	I	J	▲
011	012	013	014	015	
K	L	M	N	O	▼

016	017	018	019	020	2/2
P	Q	R	S	T	
021	022	023	024	025	
U	V	W	X	Y	▲
026	027	028	029		



001	002	003	004	005	1/5
A	B	C	D	E	
006	007	008	009	010	
F	G	H	I	J	▲
011	012	013	014	015	
K	L	M	N	O	▼

016	017	018	019	020	2/5
P	Q	R	S	T	
021	022	023	024	025	
U	V	W	X	Y	▲
026	027	028	029	030	
Z	A	B	C	D	▼

031	032	033	034	035	3/5
E	F	G	H	I	
036	037	038	039	040	
J	K	L	M	N	▲
041	042	043	044	045	
O	P	Q	R	S	▼

046	047	048	049	050	4/5
T	U	V	W	X	
051	052	053	054	055	
Y	Z				▲
056	057	058	059	060	
					▼

061	062	063	064	5/5
				▲
				▼



001	002	003	004	005	1/2
A	B	C	D	E	
006	007	008	009	010	
F	G	H	I	J	▲
011	012	013	014	015	
K	L	M	N	O	▼

016	017	018	019	020	2/2
P	Q	R	S	T	
021	022	023	024	025	
U	V	W	X	Y	▲
026					



001	002	003	004	005	1/2
A	B	C	D	E	
006	007	008	009	010	
F	G	H	I	J	▲
011	012	013	014	015	
K	L	M	N	O	▼

016	017	018	019	020	2/2
P	Q	R	S	T	
021	022	023	024	025	
U	V	W	X	Y	▲
026	027	028	029		

AB

001	A	B	C	D	E
006	F	G	H	I	J
011	K	L	M	N	O

016	P	Q	R	S	T
021	U	V	W	X	Y
026	Z	0	1	2	3

031	4	5	6	7	8
036	9				

AA

001	A	B	Γ	Δ	E
006	Z	Θ	Η	Ι	K
011	Λ	M	N	Ξ	O

016	Π	P	Σ	T	Υ
021	Φ	X	Ψ	Ω	

AA

00	<i>ABC</i>				
01	ABC	ABC	ABC		
04	ABC	ABC	ABC		
07	ABC	ABC	ABC		
10	ABC	ABC	ABC		
13	ABC	ABC	ABC		

16	ABC	ABC	ABC		
19	ABC	ABC	ABC		
22	ABC	ABC	ABC		
25	ABCD	ABCD	ABCD		
28	ABCD	ABCD	ABCD		
30	ABV	ABV			

32	あいう	あいう	あいう		
T01	ABC				

00 *ABC*

ABC	abc	0-9,.	&?!	ÄÄä	ÑÑñ
A	B	C	D	E	F
G	H	I	J	K	L
M	N	O	P	Q	R
S	T	U	V	W	X
Y	Z				

ABC	abc	0-9,.	&?!	ÄÄä	ÑÑñ
a	b	c	d	e	f
g	h	i	j	k	l
m	n	o	p	q	r
s	t	u	v	w	x
y	z				

ABC	abc	0-9,.	&?!	ÄÄä	ÑÑñ
0	1	2	3	4	5
6	7	8	9	#	%
\$	€	¥	-	+	x
÷	=	*	.	,	

ABC	abc	0-9,.	&?!	ÄÄä	ÑÑñ
g	p	/	@	<	>
/	/	/	\	~	.
@	TM	"	"	"	'

ABC	abc	0-9,.	&?!	ÄÄä	ÑÑñ
A	Ä	Å	Æ	à	á
â	ä	æ	ç	ç	Đ
È	É	è	é	ê	ë
í	ï	ì	í	î	ï

ABC	abc	0-9,.	&?!	ÄÄä	ÑÑñ
N	N	n	Ö	Ö	ø
Ó	ó	ô	ö	ø	œ
í	Û	Ü	ù	ú	ü
ƒ	ß	ß			

01 ABC

ABC	abc	0-9,.	&?!	ÄÄä	ÑÑñ
A	B	C	D	E	F
G	H	I	J	K	L
M	N	O	P	Q	R
S	T	U	V	W	X
Y	Z				

ABC	abc	0-9,.	&?!	ÄÄä	ÑÑñ
a	b	c	d	e	f
g	h	i	j	k	l
m	n	o	p	q	r
s	t	u	v	w	x
y	z				

ABC	abc	0-9,.	&?!	ÄÄä	ÑÑñ
0	1	2	3	4	5
6	7	8	9	#	%
\$	€	¥	-	+	x
÷	=	*	.	,	

ABC	abc	0-9,.	&?!	ÄÄä	ÑÑñ
&	?	!	@	<	>
()	[]	/	\
~	:	;	©	®	™
"	"	"	'	'	'

ABC	abc	0-9,.	&?!	ÄÄä	ÑÑñ
Â	Ã	Ä	Å	Æ	à
á	â	ä	æ	ç	ç
Đ	È	É	ê	ë	í
ï	ì	í	î	ï	ì

ABC	abc	0-9,.	&?!	ÄÄä	ÑÑñ
Ñ	Ñ	ñ	Ô	Ö	ø
Ó	ó	ô	ö	ø	œ
í	Û	Ü	ù	ú	ü
ƒ	ß	ß			

刺しゅう模様一覧

02 ABC

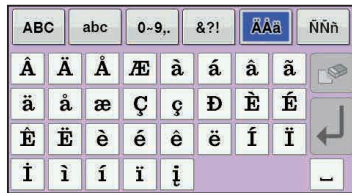
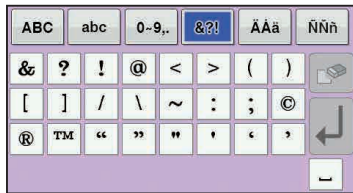
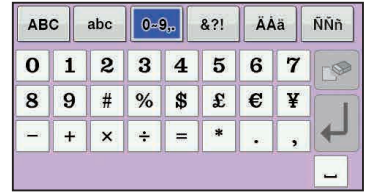
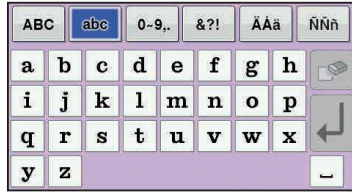
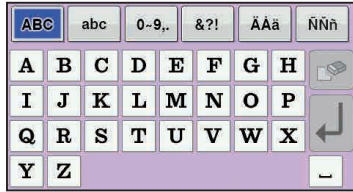

03 ABC

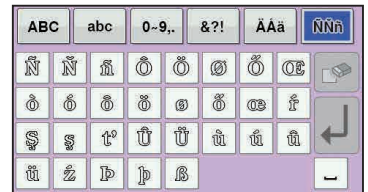
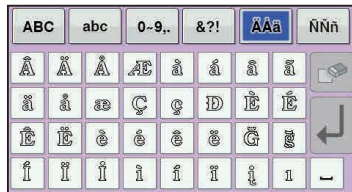
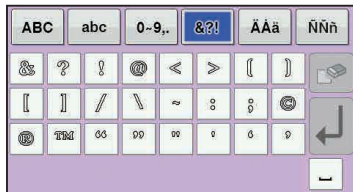
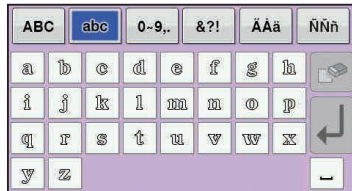
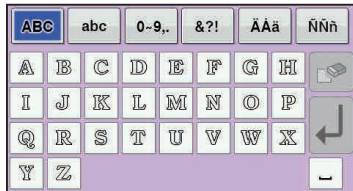

04 ABC

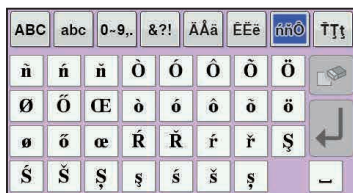
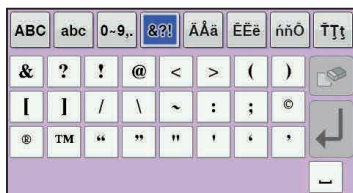
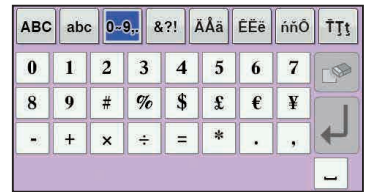
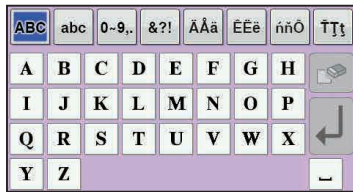

05 ABC

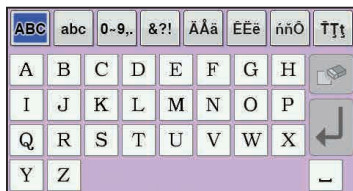

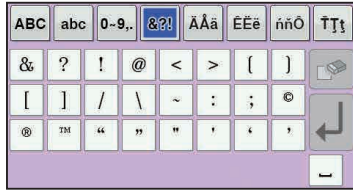

06 ABC

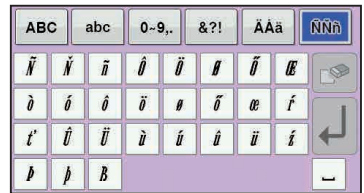
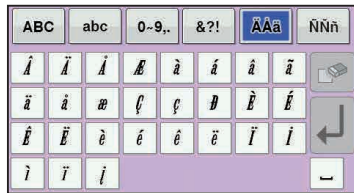
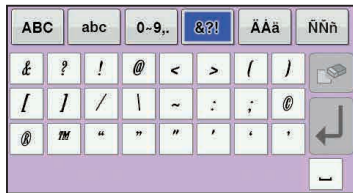
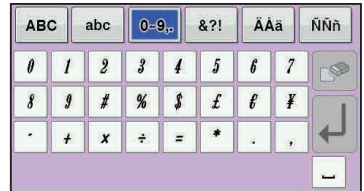
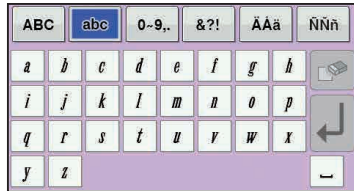
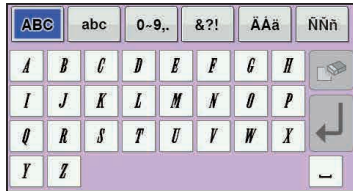

07 ABC

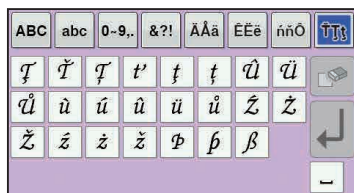
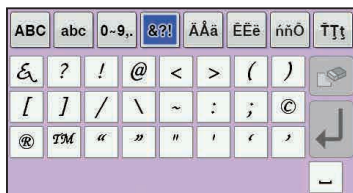
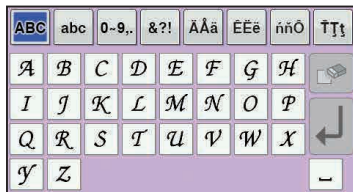

08 ABC

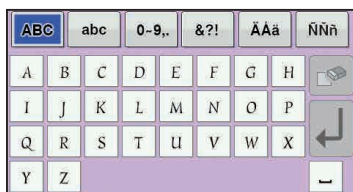

刺しゅう模様一覧

09
ABC

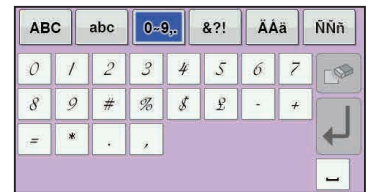
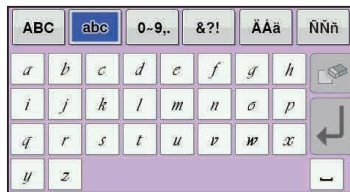
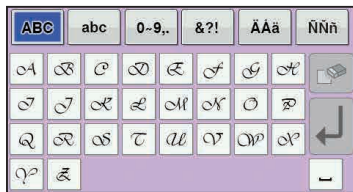
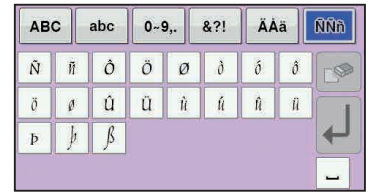
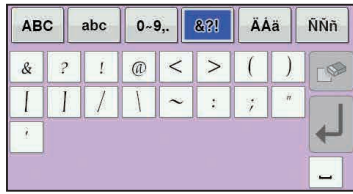

10
ABC

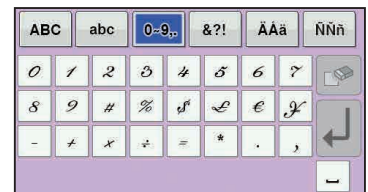
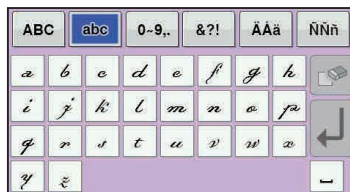
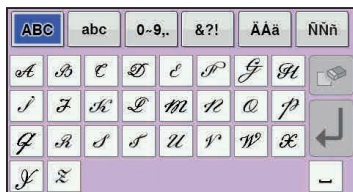
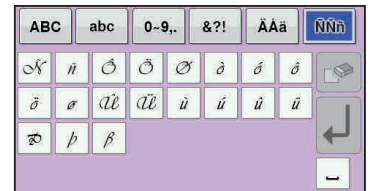
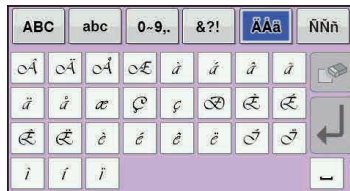
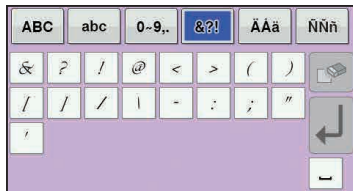

11
ABC

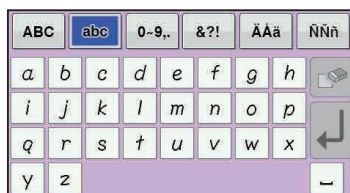
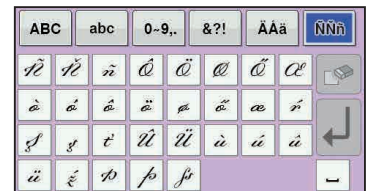
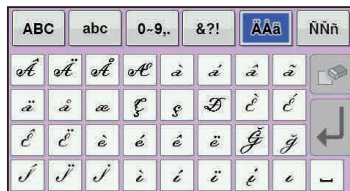
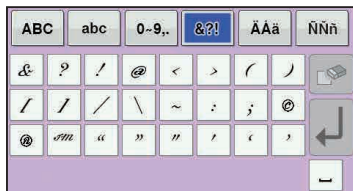

12
ABC

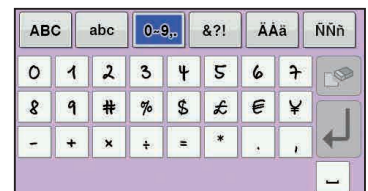
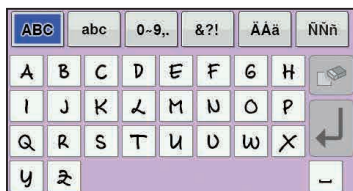
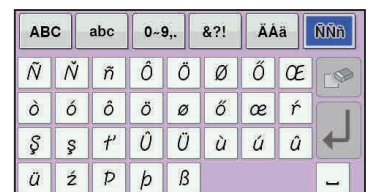
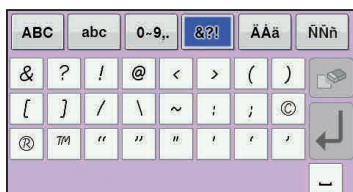

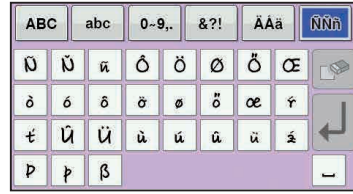
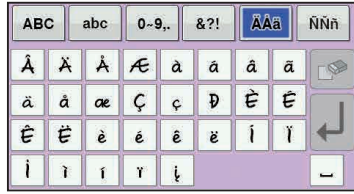
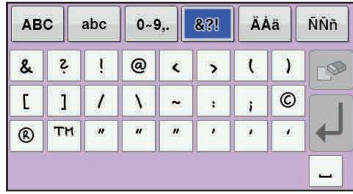

13 ABC

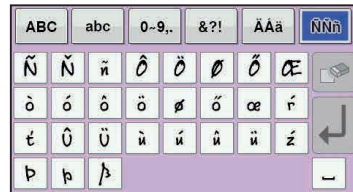
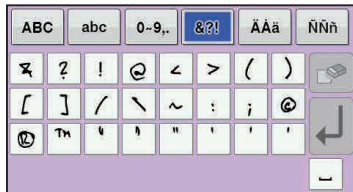
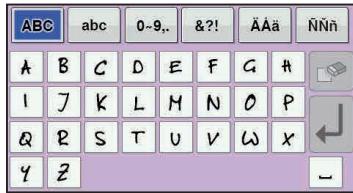

14 ABC

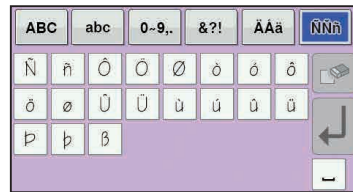
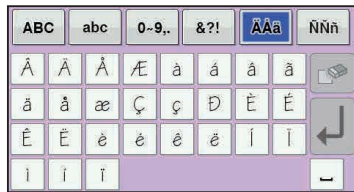
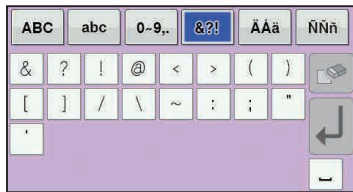
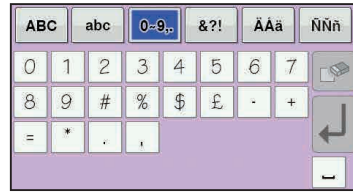
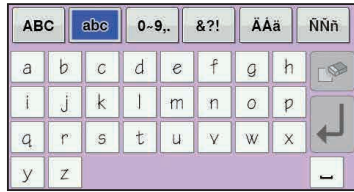
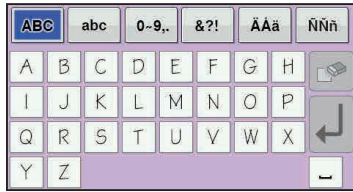

15 ABC

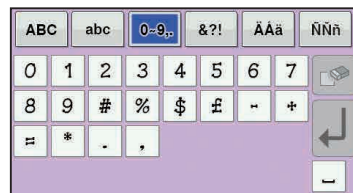
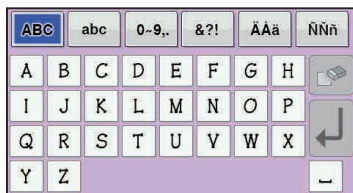

16 ABC

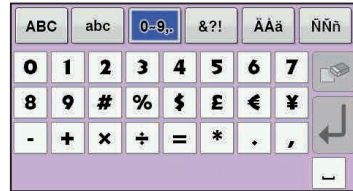
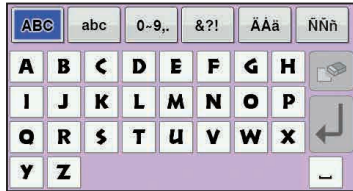

刺しゅう模様一覧

17 ABC

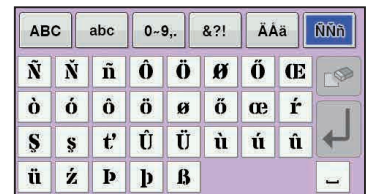
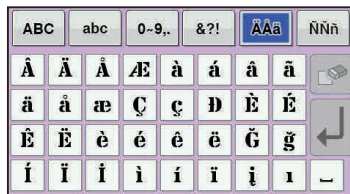
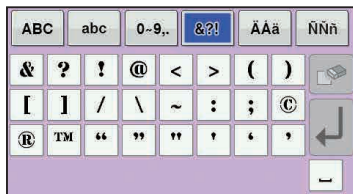
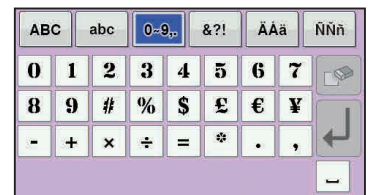
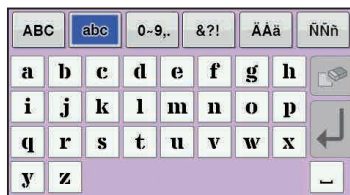
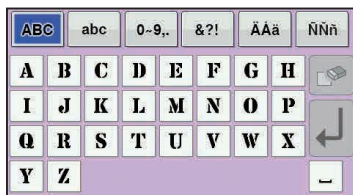
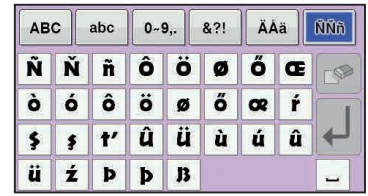
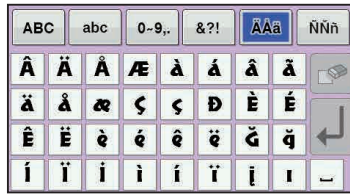
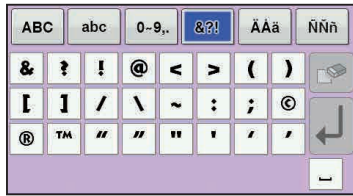

18 ABC

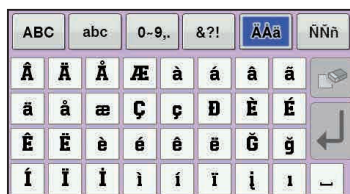
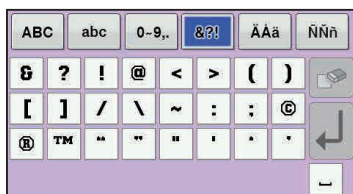
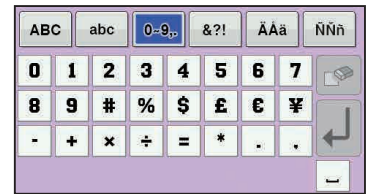
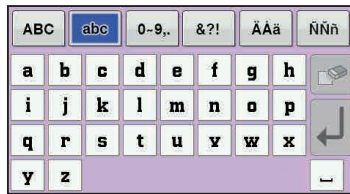
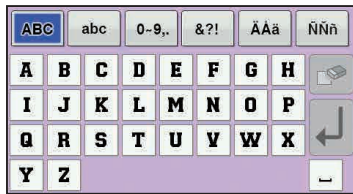

19 ABC

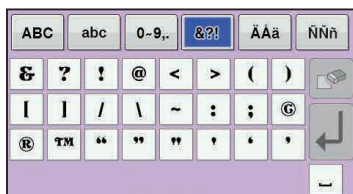
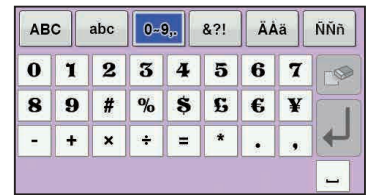
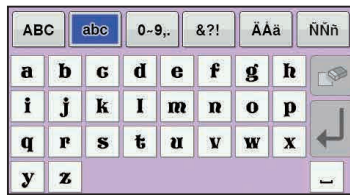
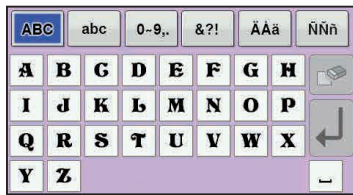

20 ABC

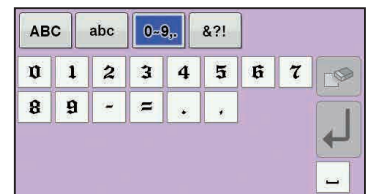
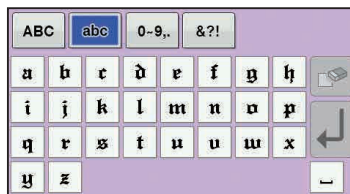
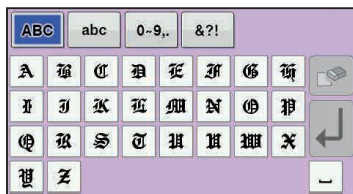

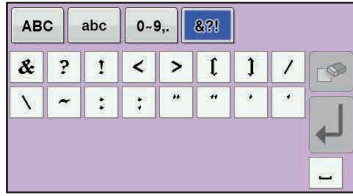

21 ABC

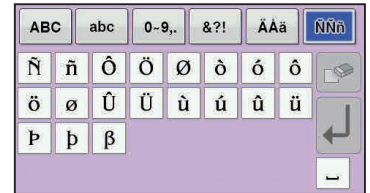
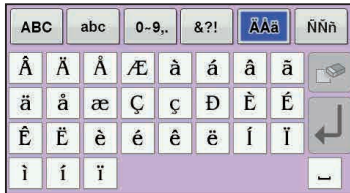
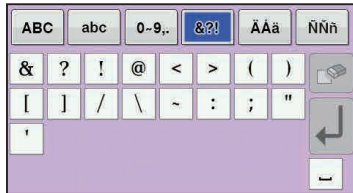
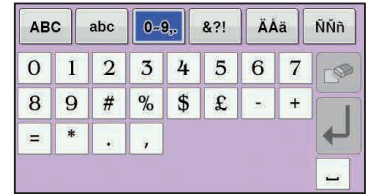
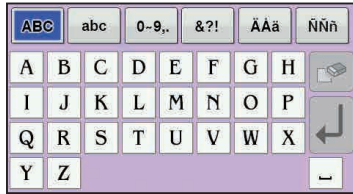

22 ABC

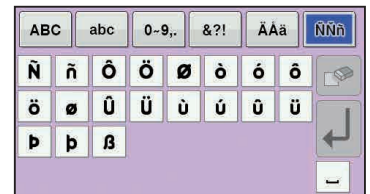
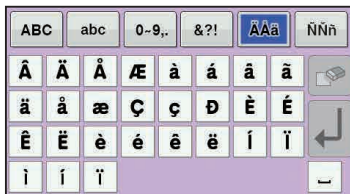
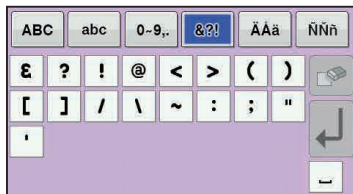
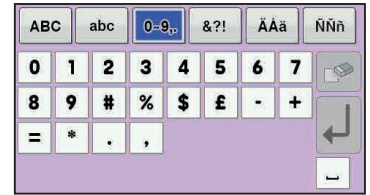
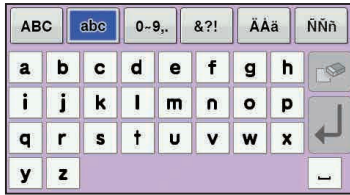
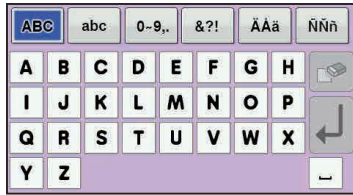

23 ABC

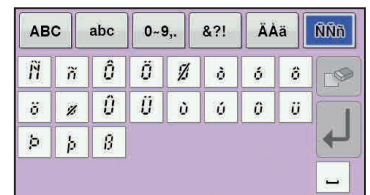
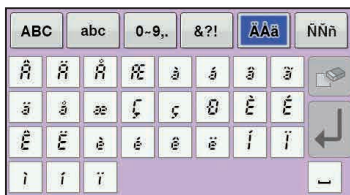
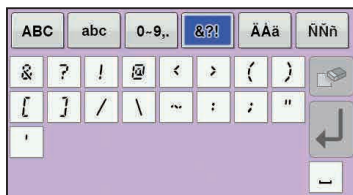
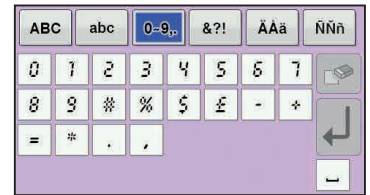
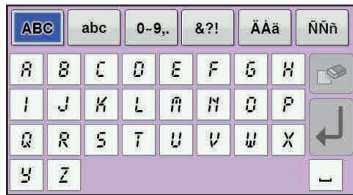

24 ABC

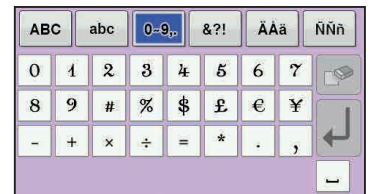
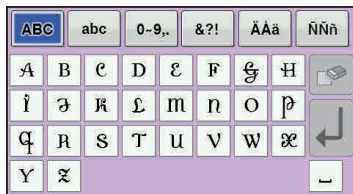

刺しゅう模様一覧

25
ABCD

ミニサイズ文字

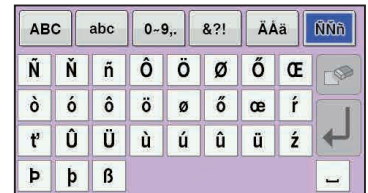
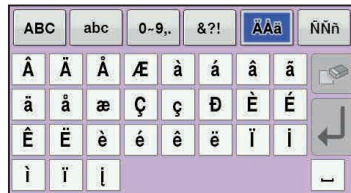
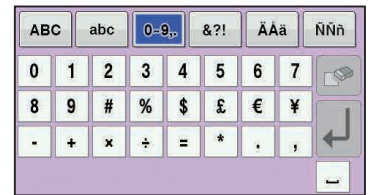
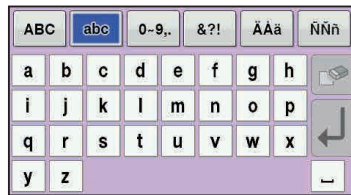
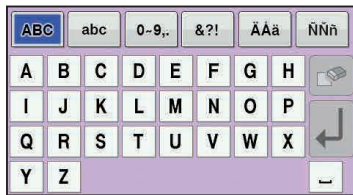
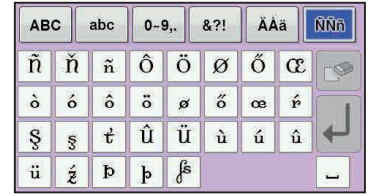
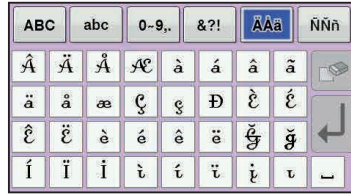
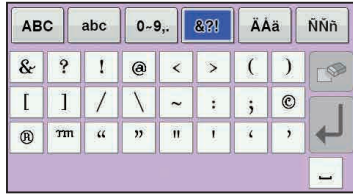

26
ABCD

ミニサイズ文字

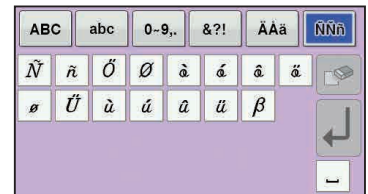
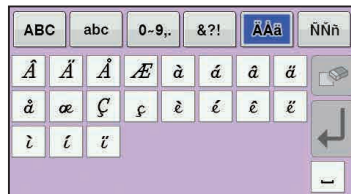
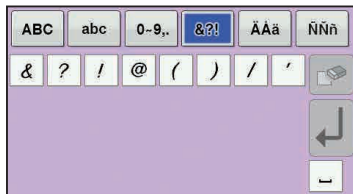
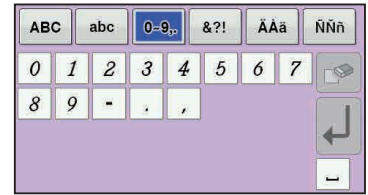
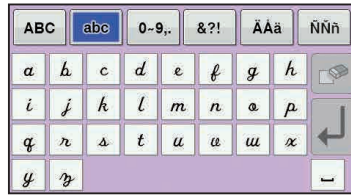
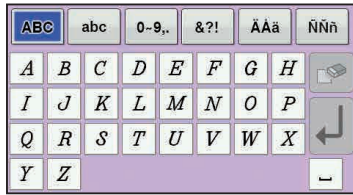

27
ABCD

ミニサイズ文字

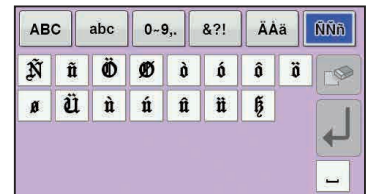
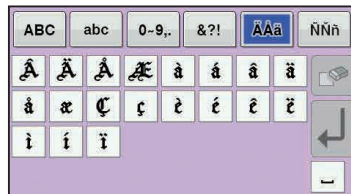
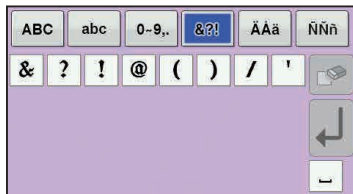
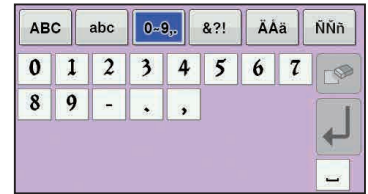
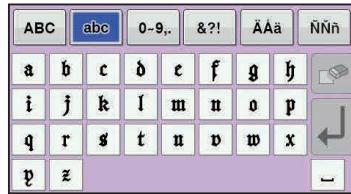
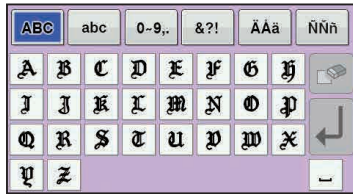

28
ABCD

ミニサイズ文字

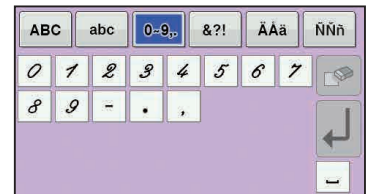
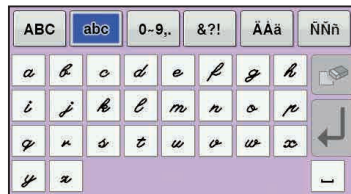
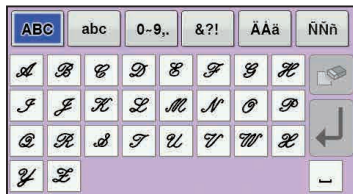

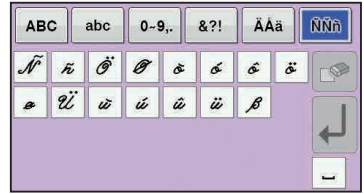
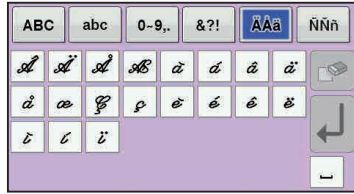
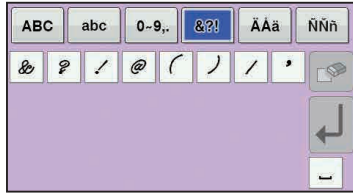

29
ABCDEFGH

ミニサイズ文字

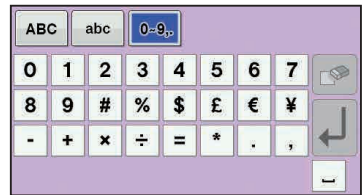
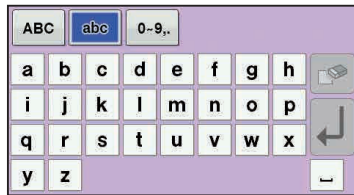
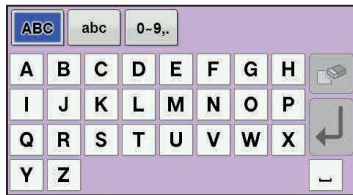

30
АБВ



31
АБВ



32
あいう



刺しゅう模様一覧

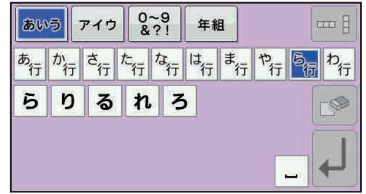
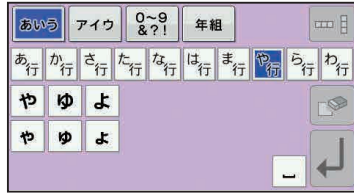
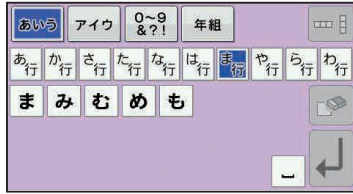

33 あいう

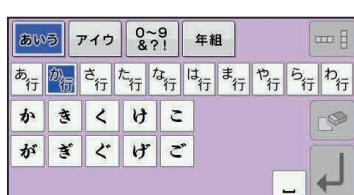
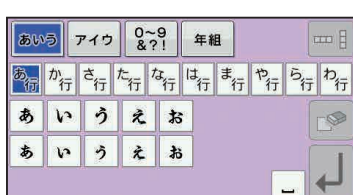

あいう アイウ 0~9 &?! 年組

あ 行 か 行 さ 行 た 行 な 行 は 行 ま 行 や 行 ら 行 わ 行

ま み む め も

あいう アイウ 0~9 &?! 年組

あ 行 か 行 さ 行 た 行 な 行 は 行 ま 行 や 行 ら 行 わ 行

や ゆ よ

や ゆ よ

あいう アイウ 0~9 &?! 年組

あ 行 か 行 さ 行 た 行 な 行 は 行 ま 行 や 行 ら 行 わ 行

ら り る れ ろ

あいう アイウ 0~9 &?! 年組

あ 行 か 行 さ 行 た 行 な 行 は 行 ま 行 や 行 ら 行 わ 行

わ を ん

あいう アイウ 0~9 &?! 年組

ア 行 カ 行 サ 行 タ 行 ナ 行 ハ 行 マ 行 ヤ 行 ラ 行 ワ 行

ア イ ウ エ オ

ア イ ウ エ オ

ヅ

あいう アイウ 0~9 &?! 年組

ア 行 カ 行 サ 行 タ 行 ナ 行 ハ 行 マ 行 ヤ 行 ラ 行 ワ 行

カ キ ク ケ コ

ガ ギ グ ゲ ゴ

あいう アイウ 0~9 &?! 年組

ア 行 カ 行 サ 行 タ 行 ナ 行 ハ 行 マ 行 ヤ 行 ラ 行 ワ 行

サ シ ス セ ソ

ザ ジ ズ ゼ ゾ

あいう アイウ 0~9 &?! 年組

ア 行 カ 行 サ 行 タ 行 ナ 行 ハ 行 マ 行 ヤ 行 ラ 行 ワ 行

タ チ ツ テ ト

ダ チ ズ デ ド

ッ

あいう アイウ 0~9 &?! 年組

ア 行 カ 行 サ 行 タ 行 ナ 行 ハ 行 マ 行 ヤ 行 ラ 行 ワ 行

ナ ニ ス ネ ノ

あいう アイウ 0~9 &?! 年組

ア 行 カ 行 サ 行 タ 行 ナ 行 ハ 行 マ 行 ヤ 行 ラ 行 ワ 行

ハ ヒ フ ヘ ホ

バ ビ ブ ベ ボ

パ ピ プ ペ ポ

あいう アイウ 0~9 &?! 年組

ア 行 カ 行 サ 行 タ 行 ナ 行 ハ 行 マ 行 ヤ 行 ラ 行 ワ 行

マ ミ ム メ モ

あいう アイウ 0~9 &?! 年組

ア 行 カ 行 サ 行 タ 行 ナ 行 ハ 行 マ 行 ヤ 行 ラ 行 ワ 行

ヤ ヌ ヨ

ヤ ヌ ヨ

あいう アイウ 0~9 &?! 年組

ア 行 カ 行 サ 行 タ 行 ナ 行 ハ 行 マ 行 ヤ 行 ラ 行 ワ 行

ラ リ ル レ ロ

あいう アイウ 0~9 &?! 年組

ア 行 カ 行 サ 行 タ 行 ナ 行 ハ 行 マ 行 ヤ 行 ラ 行 ワ 行

ワ ラ ン

あいう アイウ 0~9 &?! 年組

0 1 2 3 4 5 6 7

8 9 0 ー 二 三 四 五

六 七 八 九 十 & ? !

() ー

あいう アイウ 0~9 &?! 年組

生 年 月 日 才 小 中 学

校 組 火 水 木 金 土 保

育 幼 稚 園 番 部 班 会

係 名 前

34 あいう

あいう アイウ 0~9 &?! 年組

あ 行 か 行 さ 行 た 行 な 行 は 行 ま 行 や 行 ら 行 わ 行

あ い う え お

あ い う え お

あいう アイウ 0~9 &?! 年組

あ 行 か 行 さ 行 た 行 な 行 は 行 ま 行 や 行 ら 行 わ 行

か き く け こ

が ぎ ぐ げ ご

あいう アイウ 0~9 &?! 年組

あ 行 か 行 さ 行 た 行 な 行 は 行 ま 行 や 行 ら 行 わ 行

さ し す せ そ

ざ じ ず ぜ ぞ

あいう アイウ 0~9 &?! 年組

あ 行 か 行 さ 行 た 行 な 行 は 行 ま 行 や 行 ら 行 わ 行

た ち つ て と

だ ち づ で ど

っ

あいう アイウ 0~9 &?! 年組

あ 行 か 行 さ 行 た 行 な 行 は 行 ま 行 や 行 ら 行 わ 行

な に め ね の

あいう アイウ 0~9 &?! 年組

あ 行 か 行 さ 行 た 行 な 行 は 行 ま 行 や 行 ら 行 わ 行

は ひ ふ へ ほ

ば び ぶ べ ぼ

ば び ぶ べ ぼ

刺しゅう模様一覧

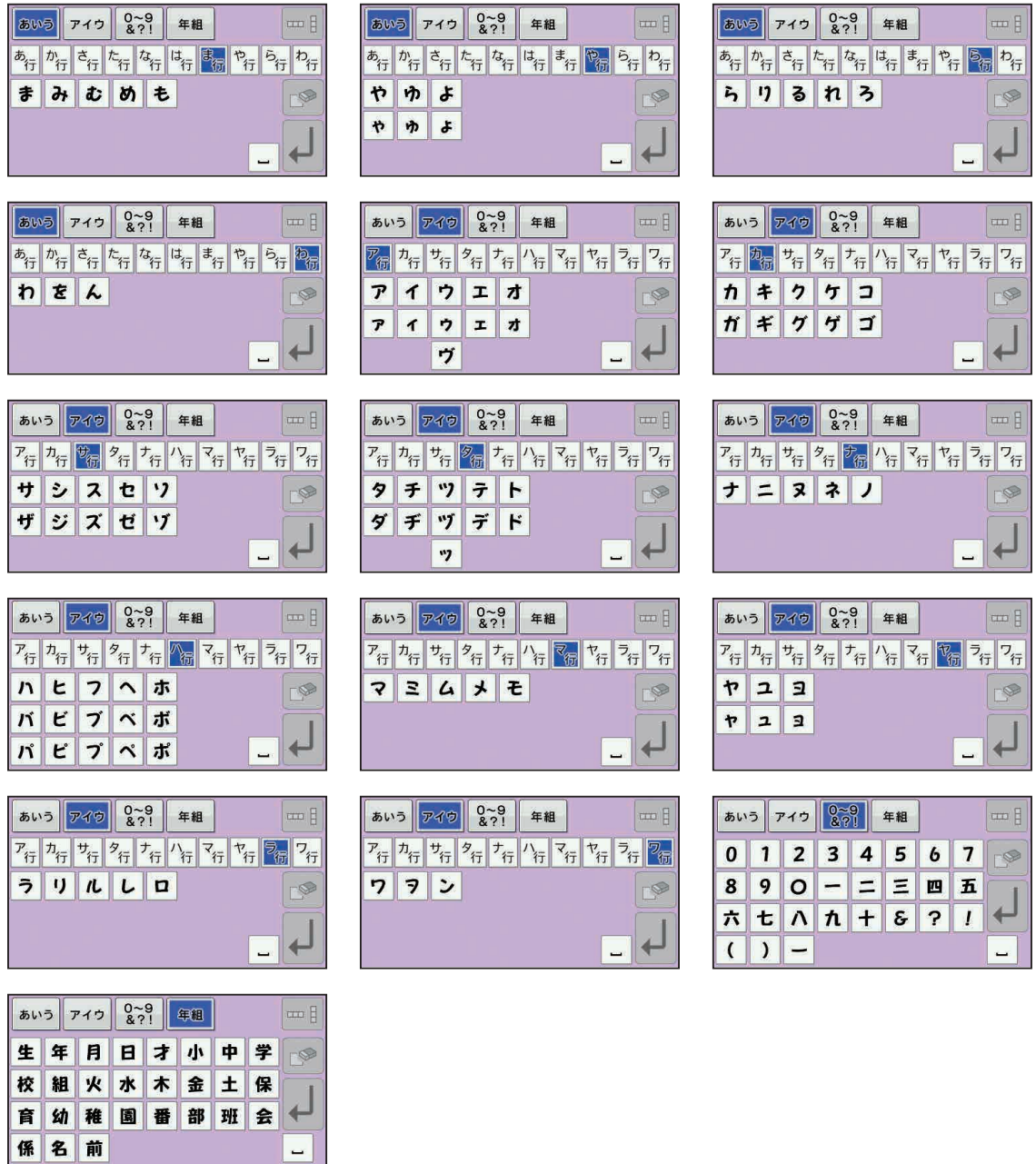

● 実寸例

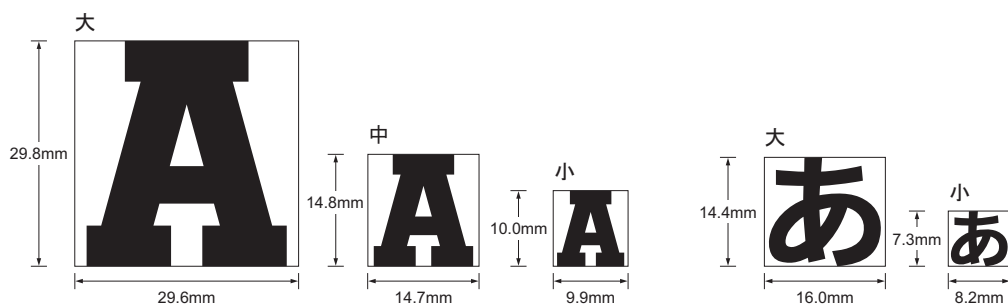

T01
ABC

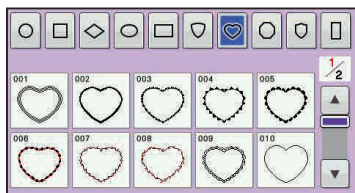
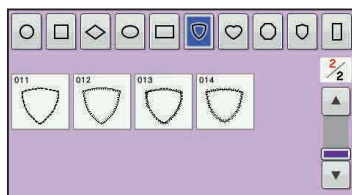
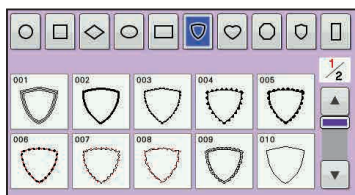
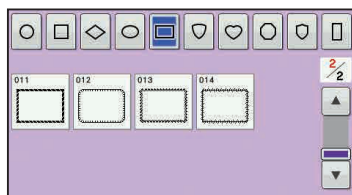
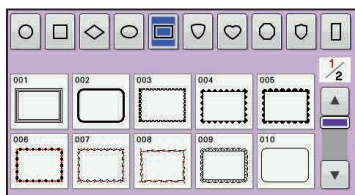
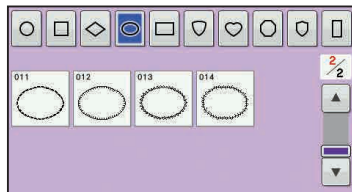
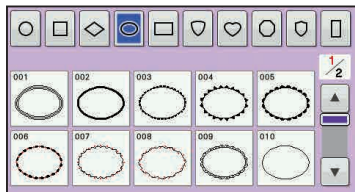
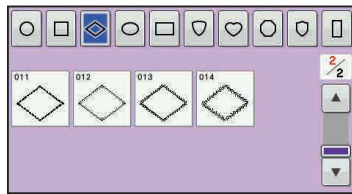
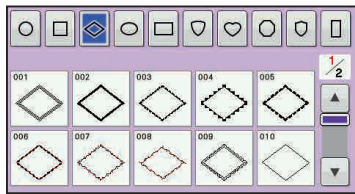
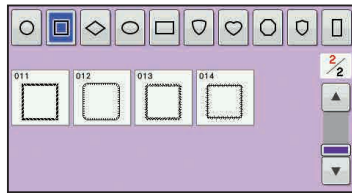
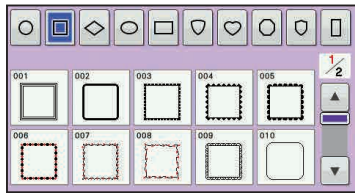
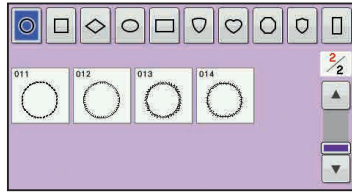
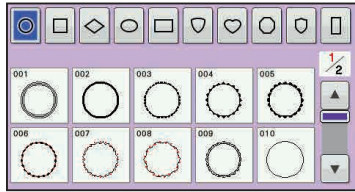
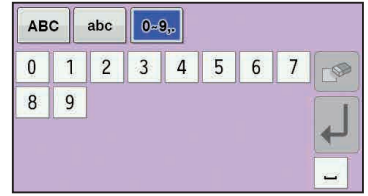
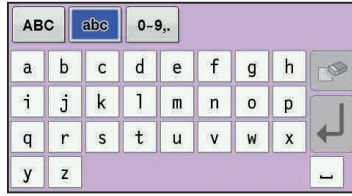
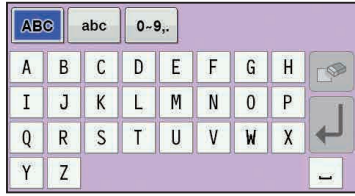

刺しゅう模様一覧

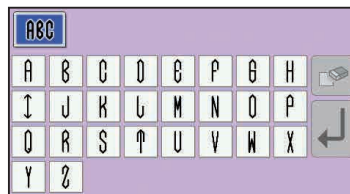
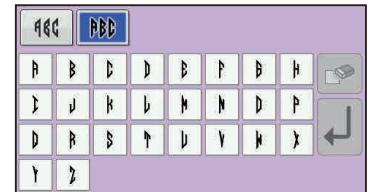
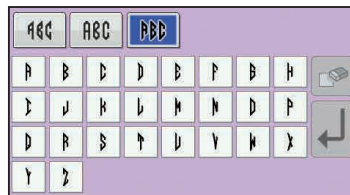
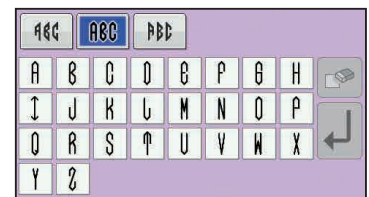
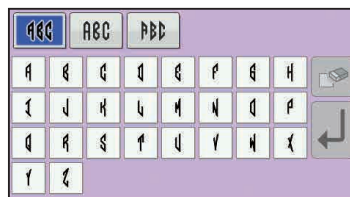
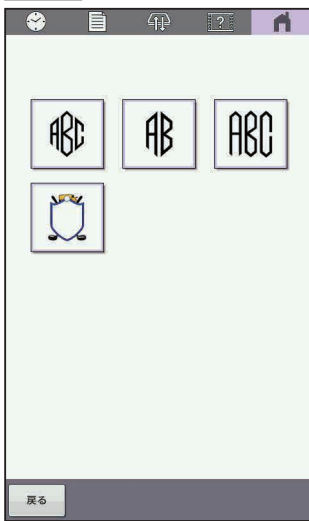
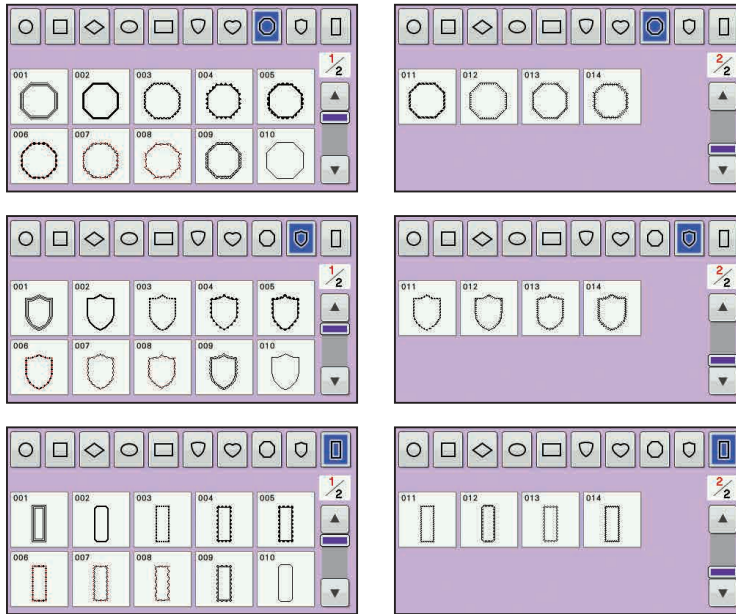

刺しゅう色替え表

各模様刺しゅうの時間と大きさは、画面に表示される情報と異なることがあります。参考目的としてのみお使いください。
 特に明記されていない限り、本冊子に掲載されている糸色番号はブラザー刺しゅう糸のものです。
 (●) 番号に●印のある模様は、回転された状態でミシンに内蔵されています。縫製前に模様の配置を確認してください。

※ 注目のデザイン

● 注目のデザイン1



No.1

21 分		刺しゅう時間
ぬい番号	1 (001)	刺しゅう糸の番号
	2 (900)	
	70.4 mm	大きさ
	125.9 mm	

刺しゅう糸の色

No.2

17 分	
1	(208)
2	(900)
↓	107.8 mm
↔	87.0 mm

● No.4

108 分	
1	(704)
2	(005)
3	(900)
4	(704)
5	(005)
6	(900)
7	(005)
8	(704)
9	(005)
10	(704)
11	(005)
12	(900)
13	(005)
↓	195.0 mm
↔	264.5 mm

● No.3

95 分	
1	(399)
2	(001)
3	(214)
4	(900)
5	(214)
↓	193.4 mm
↔	238.5 mm

● No.5

15 分	
1	(613)
2	(086)
3	(070)
4	(613)
5	(070)
6	(534)
↓	162.0 mm
↔	255.3 mm

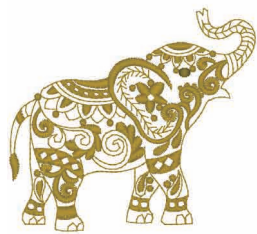

No.6

7分	
1	(328)
2	(330)
↓	85.5 mm
↔	94.8 mm



No.7

14分	
1	(900)
↓	84.8 mm
↔	131.1 mm



No.8

31分	
1	(085)
↓	152.0 mm
↔	185.1 mm



● No.9

113分			
1	(307)	17	(507)
2	(900)	18	(085)
3	(307)	19	(807)
4	(807)	20	(085)
5	(513)	21	(807)
6	(507)	22	(085)
7	(513)	23	(307)
8	(507)	24	(807)
9	(513)	25	(513)
10	(507)	26	(507)
11	(807)	27	(807)
12	(513)	28	(507)
13	(507)	29	(513)
14	(513)	30	(085)
15	(507)	31	(807)
16	(513)	32	(085)
↓ 183.2 mm ↔ 277.5 mm			

●注目のデザイン2



BOHO

No.1

7分	
1	(800)
2	(348)
↓	50.0 mm
↔	91.9 mm

GROOVY

No.2

10分	
1	(513)
2	(085)
3	(348)
4	(620)
↓	43.3 mm
↔	148.2 mm

GOOD VIBES

No.3

15分	
1	(534)
2	(030)
3	(208)
↓	98.8 mm
↔	109.7 mm



No.4

30分	
1	(542)
2	(085)
3	(812)
4	(620)
5	(030)
↓	194.6 mm
↔	276.9 mm



No.5

6分	
1	(542)
2	(812)
3	(030)
↓	147.2 mm
↔	44.2 mm

ワンポイント



No.1 4分

1		(107)
2		(007)
3		(005)
4		(007)
5		(107)
↓	40.1 mm	
↔	41.3 mm	

No.2 2分

1		(812)
2		(205)
↓	32.1 mm	
↔	30.2 mm	

No.3 1分

1		(612)
2		(515)
3		(534)
4		(620)
↓	28.2 mm	
↔	27.4 mm	

No.4 1分

1		(079)
2		(001)
3		(058)
↓	19.1 mm	
↔	29.3 mm	

No.5 2分

1		(509)
2		(515)
↓	26.3 mm	
↔	26.6 mm	

No.6 1分

1		(399)
2		(348)
↓	31.2 mm	
↔	21.1 mm	

No.7 1分

1		(328)
2		(214)
↓	37.6 mm	
↔	15.3 mm	

No.8 1分

1		(001)
2		(509)
3		(058)
↓	29.9 mm	
↔	23.8 mm	

No.9 1分

1		(900)
2		(800)
3		(900)
↓	15.0 mm	
↔	16.1 mm	

No.10 2分

1		(348)
2		(001)
3		(517)
4		(515)
5		(323)
6		(058)
7		(214)
8		(208)
↓	30.8 mm	
↔	27.6 mm	

No.11 2分

1		(001)
2		(515)
3		(800)
4		(214)
5		(001)
↓	31.0 mm	
↔	30.9 mm	

No.12 7分

1		(005)
↓	68.2 mm	
↔	53.8 mm	

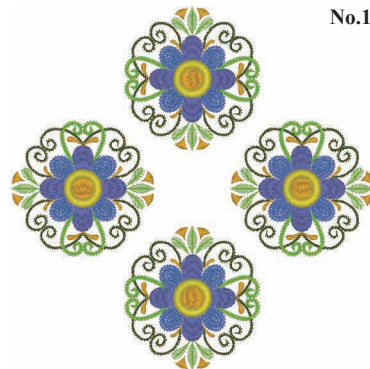

No.13 2分

1		(214)
↓	39.3 mm	
↔	38.4 mm	

No.14 6分

1		(214)
↓	68.5 mm	
↔	69.5 mm	

No.15 4分

1		(348)
2		(399)
3		(085)
4		(124)
↓	41.4 mm	
↔	49.3 mm	

No.16 13分

1		(348)
2		(124)
3		(085)
4		(399)
↓	88.1 mm	
↔	157.9 mm	

No.17 39分

1		(517)
2		(214)
3		(513)
4		(070)
5		(607)
6		(214)
7		(206)
↓	192.5 mm	
↔	192.5 mm	

刺しゅう色替え表

No.18 **36分**

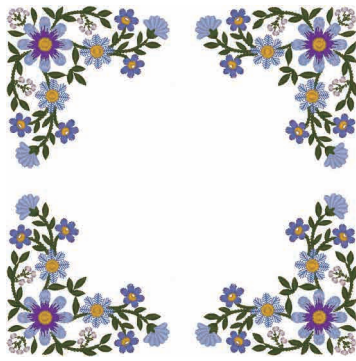

1	(399)
2	(517)
3	(607)
4	(070)
5	(804)
6	(613)
7	(214)
8	(399)
9	(517)
10	(607)
11	(070)
12	(804)
13	(613)
14	(214)

↓ 185.9 mm
↔ 185.9 mm

No.21 **36分**

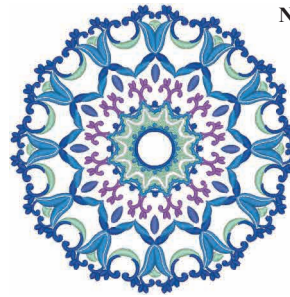

1	(612)	7	(542)
2	(405)	8	(405)
3	(542)	9	(019)
4	(001)	10	(001)
5	(019)	11	(070)
6	(405)		

↓ 153.0 mm ↔ 153.5 mm

No.22



No.19 **29分**



1	(513)
2	(085)
3	(807)
4	(507)
5	(209)
6	(206)
7	(807)

↓ 177.3 mm
↔ 177.4 mm

51分

1	(515)	15	(019)	29	(010)	43	(208)	57	(513)
2	(027)	16	(208)	30	(323)	44	(843)	58	(534)
3	(513)	17	(843)	31	(513)	45	(010)	59	(707)
4	(058)	18	(010)	32	(534)	46	(810)	60	(208)
5	(208)	19	(810)	33	(019)	47	(010)	61	(513)
6	(070)	20	(010)	34	(208)	48	(323)	62	(515)
7	(019)	21	(323)	35	(843)	49	(070)	63	(027)
8	(209)	22	(513)	36	(010)	50	(208)	64	(513)
9	(208)	23	(534)	37	(810)	51	(001)	65	(058)
10	(800)	24	(019)	38	(010)	52	(058)	66	(208)
11	(405)	25	(208)	39	(323)	53	(010)	67	(070)
12	(058)	26	(843)	40	(513)	54	(070)	68	(019)
13	(513)	27	(010)	41	(534)	55	(058)		
14	(534)	28	(810)	42	(019)	56	(620)		

↓ 195.8 mm ↔ 195.8 mm

No.20 **41分**



1	(613)
2	(001)
3	(086)
4	(542)
5	(613)
6	(001)
7	(086)
8	(542)
9	(613)
10	(001)
11	(086)
12	(542)
13	(613)
14	(001)
15	(086)
16	(542)

↓ 194.0 mm
↔ 194.0 mm

No.23 **37分**

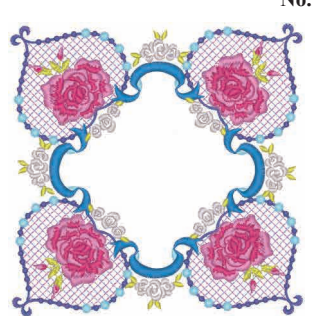

1	(804)
2	(810)
3	(607)
4	(017)
5	(019)
6	(085)
7	(086)
8	(027)
9	(124)

↓ 156.0 mm
↔ 155.1 mm



No.24 **23 分**

1	(107)
2	(086)
↕	148.2 mm
↔	195.4 mm



No.25 **22 分**

1	(405)
2	(420)
↕	148.2 mm
↔	195.4 mm



No.26 **22 分**

1	(517)
2	(515)
↕	148.2 mm
↔	195.4 mm



No.27 **22 分**

1	(007)
2	(405)
↕	148.2 mm
↔	195.4 mm



No.28 **56 分**

1	(208)	12	(307)
2	(323)	13	(126)
3	(126)	14	(333)
4	(058)	15	(208)
5	(800)	16	(126)
6	(107)	17	(001)
7	(058)	18	(800)
8	(001)	19	(058)
9	(126)	20	(107)
10	(399)	21	(399)
11	(107)	22	(058)
↕ 194.3 mm ↔ 145.2 mm			



No.29 **42 分**

1	(208)
2	(900)
3	(620)
4	(339)
5	(900)
↕	182.7 mm
↔	194.7 mm



No.30 **51 分**

1	(420)
2	(515)
3	(206)
4	(420)
5	(007)
6	(800)
7	(515)
8	(206)
9	(007)
10	(005)
11	(420)
12	(800)
↕	192.2 mm
↔	184.1 mm



No.31 **10 分**

1	(399)
2	(001)
↕	85.5 mm
↔	56.0 mm



No.32 **4 分**

1	(328)
↕	74.1 mm
↔	54.1 mm



No.33 **3 分**

1	(328)
2	(348)
↕	42.4 mm
↔	40.1 mm



No.34 **11 分**

1	(209)	6	(339)
2	(206)	7	(323)
3	(209)	8	(001)
4	(900)	9	(843)
5	(206)	10	(900)
↕ 55.2 mm ↔ 118.9 mm			

❖ 枠飾り模様



No.1 **12分**

1	■ (707)
2	■ (817)
3	■ (707)

↓ 195.6 mm
↔ 160.0 mm

No.2 **4分**

1	■ (817)
2	■ (707)

↓ 81.8 mm
↔ 111.8 mm

No.3 **3分**

1	■ (707)
2	■ (817)

↓ 39.4 mm
↔ 136.7 mm

No.4 **2分**

1	■ (900)
---	---------

↓ 25.0 mm
↔ 69.8 mm

No.5 **2分**

1	■ (900)
---	---------

↓ 40.5 mm
↔ 90.3 mm

No.6 **1分**

1	■ (900)
---	---------

↓ 24.4 mm
↔ 95.7 mm

No.7 **1分**

1	■ (900)
---	---------

↓ 18.9 mm
↔ 62.7 mm

No.8 **6分**

1	■ (900)
---	---------

↓ 62.4 mm
↔ 123.6 mm

No.9 **1分**

1	■ (900)
---	---------

↓ 23.8 mm
↔ 58.5 mm

No.10 **1分**

1	■ (900)
---	---------

↓ 40.6 mm
↔ 74.9 mm

No.11 **1分**

1	■ (900)
---	---------

↓ 15.2 mm
↔ 62.9 mm

No.12 **3分**

1	■ (900)
---	---------

↓ 37.8 mm
↔ 125.4 mm

No.13 **3分**

1	■ (900)
---	---------

↓ 24.7 mm
↔ 129.1 mm

No.14 **3分**

1	■ (900)
---	---------

↓ 32.5 mm
↔ 75.0 mm

No.15 **2分**

1	■ (900)
---	---------

↓ 8.1 mm
↔ 182.8 mm

No.16 **19分**

1	■ (399)
2	■ (804)

↓ 186.8 mm
↔ 160.1 mm

No.17 **12分**

1	■ (399)
2	■ (804)

↓ 84.6 mm
↔ 143.0 mm

No.18 **10分**

1	■ (399)
2	■ (804)

↓ 48.4 mm
↔ 188.5 mm



No.19 **19 分**

1		(328)
↕	173.7 mm	
↔	194.4 mm	



No.24 **2 分**

1		(328)
↕	47.9 mm	
↔	51.4 mm	



No.25 **1 分**

1		(869)
↕	26.0 mm	
↔	57.0 mm	



No.20 **14 分**

1		(328)
↕	137.6 mm	
↔	147.2 mm	



No.26 **2 分**

1		(007)
↕	16.8 mm	
↔	92.6 mm	



No.21 **25 分**

1		(704)
↕	154.3 mm	
↔	186.5 mm	



No.27 **1 分**

1		(005)
↕	20.7 mm	
↔	33.7 mm	



No.22 **7 分**

1		(900)
2		(085)
3		(086)
4		(807)
↕	47.9 mm	
↔	161.3 mm	

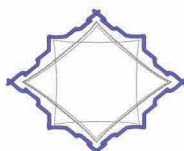

No.23 **4 分**

1		(005)
2		(817)
3		(607)
↕	77.3 mm	
↔	95.1 mm	

❖ キルト模様



No.1

5分	
1	(613)
2	(607)
↕	194.9 mm
↔	182.0 mm

No.4

2分	
1	(330)
↕	194.8 mm
↔	194.9 mm

No.2

2分	
1	(209)
↕	193.7 mm
↔	194.1 mm

No.5

2分	
1	(406)
↕	189.7 mm
↔	189.6 mm

No.3

2分	
1	(509)
↕	194.8 mm
↔	194.8 mm

No.6

7分	
1	(079)
2	(086)
↕	194.8 mm
↔	194.3 mm

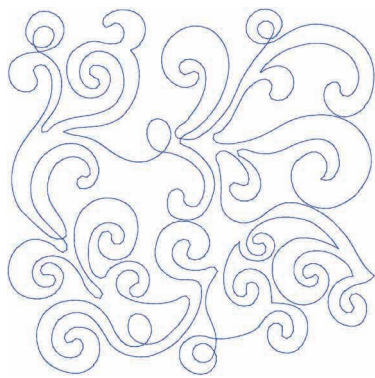

No.7 **2 分**

1	(420)
↓	194.3 mm
↔	194.6 mm

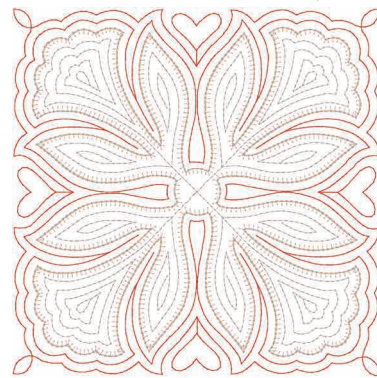

No.11 **11 分**

1	-----x (800)
2	-----x (800)
3	-----x (800)
4	(399)
5	(800)
↓	195.0 mm
↔	195.1 mm

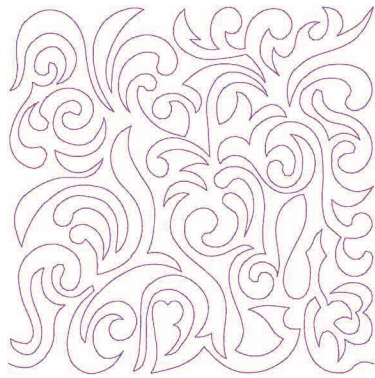

No.8 **3 分**

1	(620)
↓	194.8 mm
↔	195.0 mm

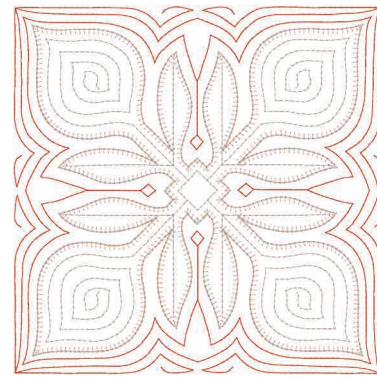

No.12 **10 分**

1	-----x (800)
2	-----x (800)
3	-----x (800)
4	(399)
5	(800)
↓	195.0 mm
↔	195.0 mm

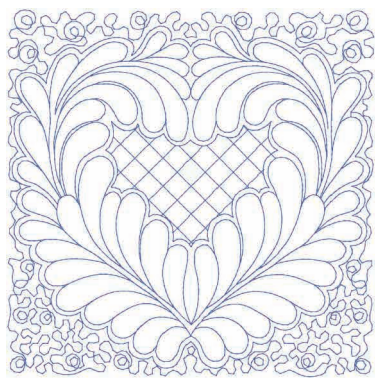

No.9 **6 分**

1	(070)
↓	195.2 mm
↔	194.5 mm



No.13 **1 分**

1	(005)
↓	60.5 mm
↔	147.9 mm

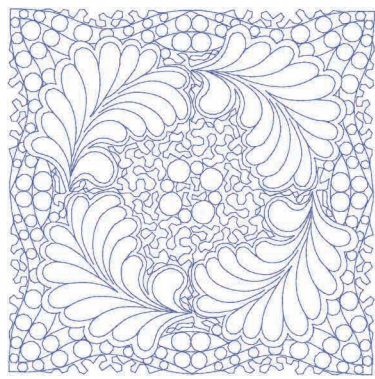

No.10 **8 分**

1	(070)
↓	194.8 mm
↔	194.9 mm



No.14 **1 分**

1	(328)
↓	73.8 mm
↔	155.8 mm



No.15 **1 分**

1	(800)
↓	27.4 mm
↔	110.7 mm





No.16 **1 分**

1	(817)
↓	63.1 mm
↔	149.9 mm

刺しゅう色替え表



No.17 **2分**



1	 (800)
↕	56.3 mm
↔	163.1 mm

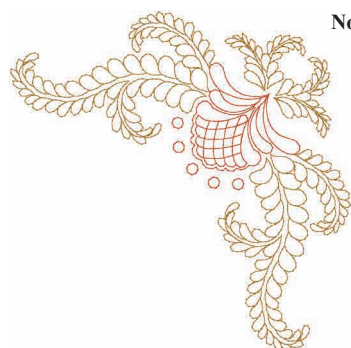

No.23 **3分**



1	 (030)
2	 (323)
↕	181.2 mm
↔	180.4 mm









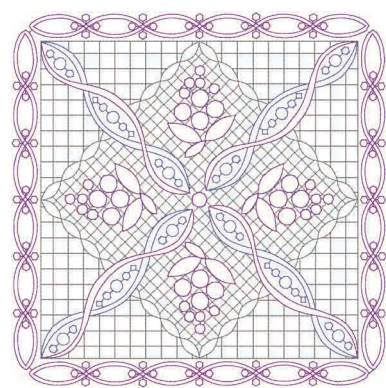



No.18 **4分**



1	 (323)
2	 (209)
↕	84.7 mm
↔	162.9 mm



No.24 **23分**



1	 (817)
2	 (620)
3	 (817)
4	 (620)
5	 (607)
6	 (817)
7	 (620)
8	 (607)
9	 (817)
10	 (620)
11	 (607)
12	 (620)
↕	199.0 mm
↔	199.0 mm

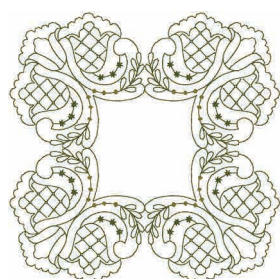

No.19 **11分**



1	 (517)
2	 (330)
↕	143.8 mm
↔	143.0 mm



No.20 **3分**



1	 (517)
2	 (330)
↕	63.5 mm
↔	103.8 mm

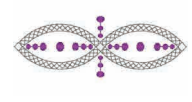

No.25 **1分**



1	 (817)
2	 (620)
↕	32.2 mm
↔	91.0 mm

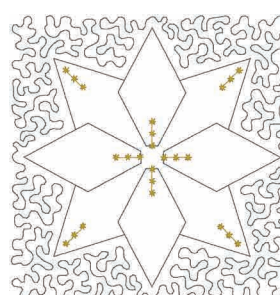



No.21 **8分**

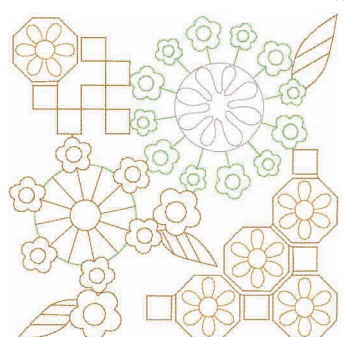

1	 (704)
2	 (328)
↕	151.1 mm
↔	149.8 mm



No.26 **10分**



1	 (509)
2	 (005)
3	 (323)
4	 (209)
↕	173.6 mm
↔	174.0 mm

No.22 **10分**



1	 (330)
2	 (328)
3	 (810)
↕	146.0 mm
↔	146.5 mm

♥ アップリケの作り方については、ミシンの取扱説明書を参照してください。



No.27 **2 分**

1	■ (323)
2	■ (509)
↕	180.9 mm
↔	45.3 mm

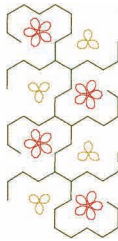

No.28 **3 分**

1	■ (517)
2	■ (208)
3	■ (800)
↕	123.9 mm
↔	59.4 mm



No.29 **3 分**

1	■ (214)
2	■ (330)
↕	95.3 mm
↔	83.5 mm



No.30 **2 分**

1	■ (330)
↕	44.2 mm
↔	162.8 mm



No.31 **11 分**

1	■ (107)
2	■ (005)
3	■ (415)
4	■ (214)
↕	188.7 mm
↔	191.2 mm

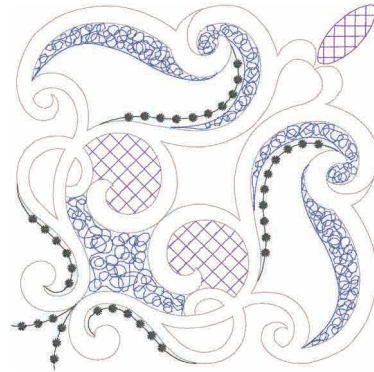

No.32 **12 分**

1	■ (005)
2	■ (070)
3	■ (704)
4	■ (612)
↕	194.2 mm
↔	194.2 mm

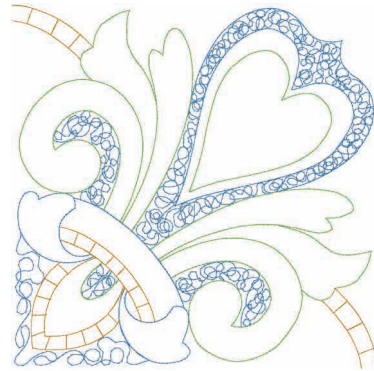

No.33 **13 分**

1	■ (019)
2	■ (509)
3	■ (209)
4	■ (019)
5	■ (509)
↕	193.2 mm
↔	193.6 mm

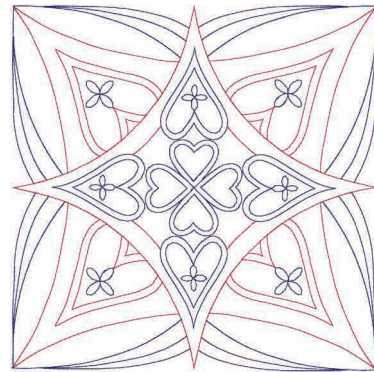

No.34 **7 分**

1	■ (107)
2	■ (007)
3	■ (107)
↕	194.4 mm
↔	193.6 mm

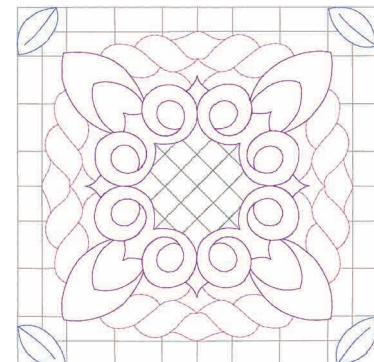

No.35 **13 分**

1	■ (817)
2	■ (005)
3	■ (810)
4	■ (620)
5	■ (070)
↕	191.2 mm
↔	191.2 mm

※ 装飾アルファベット



● 注目のデザイン (アルファベット)



No.1 9分

1	■ (030)
2	■ (900)
3	□ (001)
⇕	68.3 mm
⇔	60.2 mm

No.7 9分

1	■ (019)
2	■ (900)
3	□ (001)
⇕	62.5 mm
⇔	54.3 mm

No.13 11分

1	■ (612)
2	■ (900)
3	□ (001)
⇕	63.5 mm
⇔	68.4 mm

No.2 9分

1	■ (030)
2	■ (900)
3	□ (001)
⇕	64.7 mm
⇔	57.1 mm

No.8 8分

1	■ (019)
2	■ (900)
3	□ (001)
⇕	64.6 mm
⇔	55.9 mm

No.14 11分

1	■ (612)
2	■ (900)
3	□ (001)
⇕	68.7 mm
⇔	63.2 mm

No.3 10分

1	■ (030)
2	■ (900)
3	□ (001)
⇕	61.3 mm
⇔	55.0 mm

No.9 7分

1	■ (019)
2	■ (900)
3	□ (001)
⇕	75.7 mm
⇔	41.8 mm

No.15 7分

1	■ (612)
2	■ (900)
3	□ (001)
⇕	69.1 mm
⇔	44.5 mm

No.4 8分

1	■ (030)
2	■ (900)
3	□ (001)
⇕	64.3 mm
⇔	60.3 mm

No.10 7分

1	■ (019)
2	■ (900)
3	□ (001)
⇕	66.2 mm
⇔	48.3 mm

No.16 8分

1	■ (612)
2	■ (900)
3	□ (001)
⇕	64.0 mm
⇔	57.6 mm

No.5 9分

1	■ (030)
2	■ (900)
3	□ (001)
⇕	68.4 mm
⇔	55.1 mm

No.11 12分

1	■ (019)
2	■ (900)
3	□ (001)
⇕	72.8 mm
⇔	72.5 mm

No.17 9分

1	■ (509)
2	■ (900)
3	□ (001)
⇕	63.7 mm
⇔	53.8 mm

No.6 7分

1	■ (019)
2	■ (900)
3	□ (001)
⇕	67.8 mm
⇔	47.9 mm

No.12 7分

1	■ (612)
2	■ (900)
3	□ (001)
⇕	71.0 mm
⇔	47.8 mm

No.18 10分

1	■ (509)
2	■ (900)
3	□ (001)
⇕	64.6 mm
⇔	58.1 mm

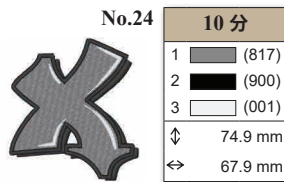
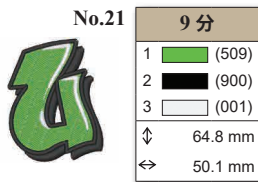
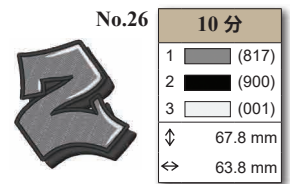
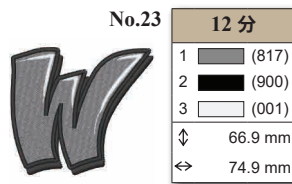
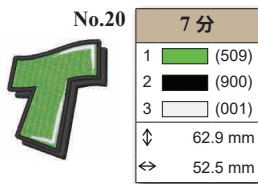
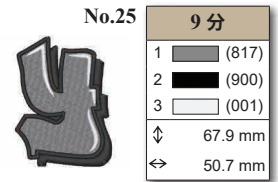
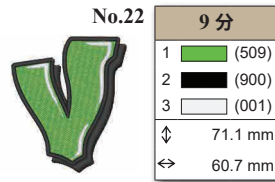
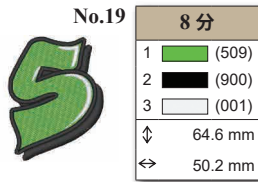

●注目のデザイン (数字)

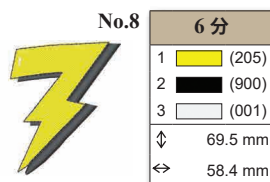
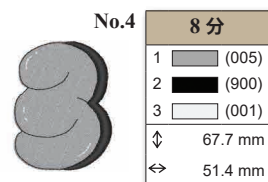
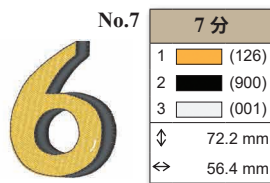
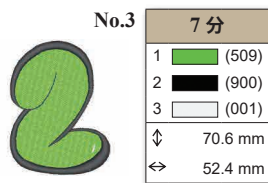
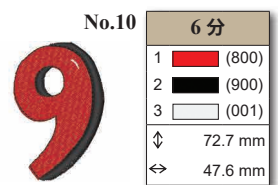
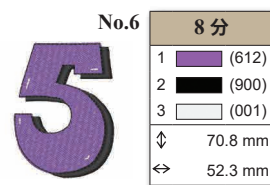
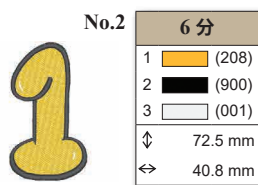
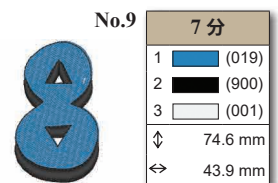
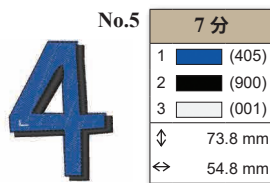
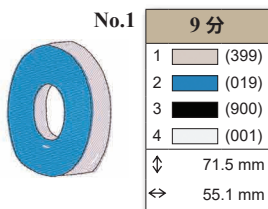

●ヴィンテージアルファベット

AB

No.1 17分

1	■ (323)
↓	148.0 mm
⇔	129.6 mm



No.6 16分

1	■ (323)
↓	149.3 mm
⇔	107.4 mm



No.11 21分

1	■ (323)
↓	149.4 mm
⇔	125.1 mm

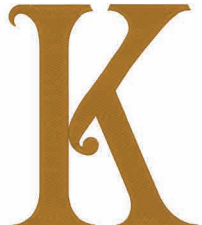

No.2 18分

1	■ (323)
↓	149.9 mm
⇔	110.9 mm



No.7 18分

1	■ (323)
↓	150.4 mm
⇔	111.7 mm



No.12 13分

1	■ (323)
↓	149.2 mm
⇔	107.1 mm



No.3 14分

1	■ (323)
↓	152.9 mm
⇔	102.3 mm



No.8 21分

1	■ (323)
↓	149.1 mm
⇔	125.6 mm



No.13 28分

1	■ (323)
↓	149.2 mm
⇔	150.1 mm



No.4 18分

1	■ (323)
↓	149.3 mm
⇔	111.7 mm



No.9 10分

1	■ (323)
↓	149.1 mm
⇔	58.0 mm



No.14 21分

1	■ (323)
↓	149.7 mm
⇔	131.1 mm



No.5 19分

1	■ (323)
↓	149.1 mm
⇔	109.7 mm



No.10 11分

1	■ (323)
↓	148.8 mm
⇔	93.9 mm



No.15 19分

1	■ (323)
↓	151.7 mm
⇔	107.1 mm



No.16 16分



1	(323)
↓	149.4 mm
↔	111.7 mm

No.22 15分



1	(323)
↓	149.1 mm
↔	110.2 mm

No.27 10分



1	(330)
↓	195.5 mm
↔	104.8 mm

No.17 18分

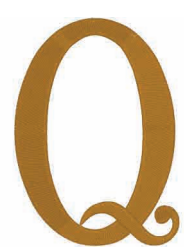

1	(323)
↓	149.6 mm
↔	108.3 mm

No.23 27分



1	(323)
↓	149.2 mm
↔	162.8 mm

No.28 11分



1	(330)
↓	136.7 mm
↔	123.3 mm

No.18 20分

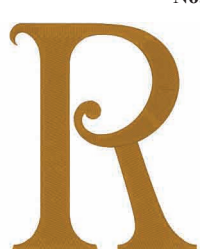

1	(323)
↓	149.5 mm
↔	123.2 mm

No.24 17分



1	(323)
↓	149.0 mm
↔	115.2 mm

No.29 4分



1	(330)
↓	85.9 mm
↔	40.0 mm

No.19 17分



1	(323)
↓	149.3 mm
↔	91.2 mm

No.25 14分



1	(323)
↓	149.2 mm
↔	120.2 mm

No.20 17分

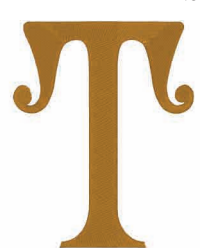

1	(323)
↓	149.2 mm
↔	118.8 mm

No.26 17分



1	(323)
↓	147.9 mm
↔	96.0 mm

No.21 17分



1	(323)
↓	149.7 mm
↔	117.4 mm

●花アルファベット



	<p>No.1 17分</p> <p>1 (328) 2 (804) 3 (612) 4 (079) 5 (807) 6 (513) 7 (502)</p> <p>↓ 145.1 mm ↔ 125.7 mm</p>		<p>No.6 16分</p> <p>1 (328) 2 (804) 3 (612) 4 (079) 5 (807) 6 (513) 7 (502)</p> <p>↓ 142.8 mm ↔ 101.8 mm</p>		<p>No.11 20分</p> <p>1 (328) 2 (804) 3 (612) 4 (079) 5 (807) 6 (513) 7 (502)</p> <p>↓ 142.0 mm ↔ 119.6 mm</p>
	<p>No.2 20分</p> <p>1 (328) 2 (804) 3 (612) 4 (079) 5 (807) 6 (513) 7 (502)</p> <p>↓ 140.9 mm ↔ 108.1 mm</p>		<p>No.7 19分</p> <p>1 (328) 2 (804) 3 (612) 4 (079) 5 (807) 6 (513) 7 (502)</p> <p>↓ 141.6 mm ↔ 117.3 mm</p>		<p>No.12 15分</p> <p>1 (328) 2 (804) 3 (612) 4 (079) 5 (807) 6 (513) 7 (502)</p> <p>↓ 144.9 mm ↔ 107.0 mm</p>
	<p>No.3 17分</p> <p>1 (328) 2 (804) 3 (612) 4 (079) 5 (807) 6 (513) 7 (502)</p> <p>↓ 141.8 mm ↔ 114.5 mm</p>		<p>No.8 22分</p> <p>1 (328) 2 (804) 3 (612) 4 (079) 5 (807) 6 (513) 7 (502)</p> <p>↓ 141.7 mm ↔ 121.6 mm</p>		<p>No.13 23分</p> <p>1 (328) 2 (804) 3 (612) 4 (079) 5 (807) 6 (513) 7 (502)</p> <p>↓ 146.5 mm ↔ 124.6 mm</p>
	<p>No.4 19分</p> <p>1 (328) 2 (804) 3 (612) 4 (079) 5 (807) 6 (513) 7 (502)</p> <p>↓ 141.2 mm ↔ 108.3 mm</p>		<p>No.9 14分</p> <p>1 (328) 2 (804) 3 (612) 4 (079) 5 (807) 6 (513) 7 (502)</p> <p>↓ 145.8 mm ↔ 49.7 mm</p>		<p>No.14 20分</p> <p>1 (328) 2 (804) 3 (612) 4 (079) 5 (807) 6 (513) 7 (502)</p> <p>↓ 147.0 mm ↔ 116.8 mm</p>
	<p>No.5 18分</p> <p>1 (328) 2 (804) 3 (612) 4 (079) 5 (807) 6 (513) 7 (502)</p> <p>↓ 144.3 mm ↔ 102.5 mm</p>		<p>No.10 15分</p> <p>1 (328) 2 (804) 3 (612) 4 (079) 5 (807) 6 (513) 7 (502)</p> <p>↓ 144.5 mm ↔ 82.3 mm</p>		<p>No.15 18分</p> <p>1 (328) 2 (804) 3 (612) 4 (079) 5 (807) 6 (513) 7 (502)</p> <p>↓ 146.3 mm ↔ 115.3 mm</p>

No.16 17分



1	(328)
2	(804)
3	(612)
4	(079)
5	(807)
6	(513)
7	(502)

↓ 143.4 mm
↔ 99.6 mm

No.20 18分



1	(328)
2	(804)
3	(612)
4	(079)
5	(807)
6	(513)
7	(502)

↓ 144.5 mm
↔ 118.4 mm

No.24 19分



1	(328)
2	(804)
3	(612)
4	(079)
5	(807)
6	(513)
7	(502)

↓ 142.3 mm
↔ 115.9 mm

No.17 20分



1	(328)
2	(804)
3	(612)
4	(079)
5	(807)
6	(513)
7	(502)

↓ 142.7 mm
↔ 118.2 mm

No.21 18分



1	(328)
2	(804)
3	(612)
4	(079)
5	(807)
6	(513)
7	(502)

↓ 144.6 mm
↔ 118.5 mm

No.25 17分



1	(328)
2	(804)
3	(612)
4	(079)
5	(807)
6	(513)
7	(502)

↓ 142.8 mm
↔ 116.3 mm

No.18 21分



1	(328)
2	(804)
3	(612)
4	(079)
5	(807)
6	(513)
7	(502)

↓ 143.4 mm
↔ 112.5 mm

No.22 17分



1	(328)
2	(804)
3	(612)
4	(079)
5	(807)
6	(513)
7	(502)

↓ 145.5 mm
↔ 121.5 mm

No.26 19分



1	(328)
2	(804)
3	(612)
4	(079)
5	(807)
6	(513)
7	(502)

↓ 142.8 mm
↔ 92.9 mm

No.19 21分



1	(328)
2	(804)
3	(612)
4	(079)
5	(807)
6	(513)
7	(502)

↓ 144.1 mm
↔ 99.4 mm

No.23 23分



1	(328)
2	(804)
3	(612)
4	(079)
5	(807)
6	(513)
7	(502)

↓ 146.2 mm
↔ 124.8 mm

◆アレンジ例

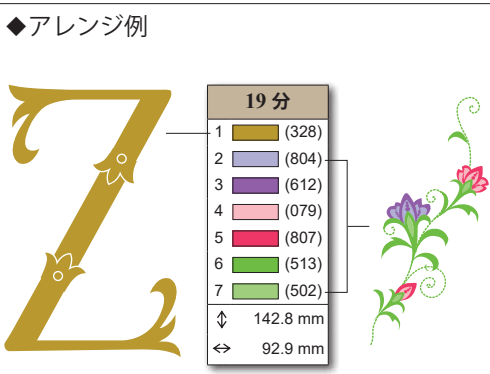

1	(328)
2	(804)
3	(612)
4	(079)
5	(807)
6	(513)
7	(502)

↓ 142.8 mm
↔ 92.9 mm

No.27 3分

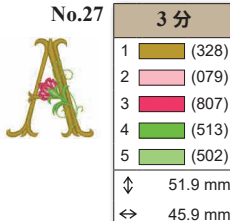

1	(328)
2	(079)
3	(807)
4	(513)
5	(502)

↓ 51.9 mm
↔ 45.9 mm

No.29 3分

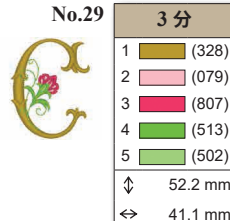

1	(328)
2	(079)
3	(807)
4	(513)
5	(502)

↓ 52.2 mm
↔ 41.1 mm

No.31 3分

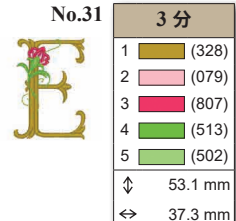

1	(328)
2	(079)
3	(807)
4	(513)
5	(502)

↓ 53.1 mm
↔ 37.3 mm

No.28 3分

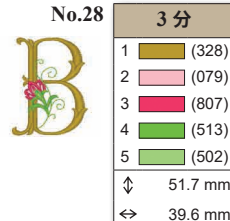

1	(328)
2	(079)
3	(807)
4	(513)
5	(502)

↓ 51.7 mm
↔ 39.6 mm

No.30 3分



1	(328)
2	(079)
3	(807)
4	(513)
5	(502)

↓ 51.9 mm
↔ 39.3 mm

No.32 3分



1	(328)
2	(079)
3	(807)
4	(513)
5	(502)

↓ 52.1 mm
↔ 36.6 mm

刺しゅう色替え表

No.33 3分



1	(328)
2	(079)
3	(807)
4	(513)
5	(502)
↓	51.9 mm
↔	42.7 mm

No.38 3分



1	(328)
2	(079)
3	(807)
4	(513)
5	(502)
↓	52.5 mm
↔	38.9 mm

No.43 3分



1	(328)
2	(079)
3	(807)
4	(513)
5	(502)
↓	52.6 mm
↔	43.3 mm

No.48 3分



1	(328)
2	(079)
3	(807)
4	(513)
5	(502)
↓	52.8 mm
↔	43.9 mm

No.34 4分



1	(328)
2	(079)
3	(807)
4	(513)
5	(502)
↓	52.2 mm
↔	44.3 mm

No.39 5分



1	(328)
2	(079)
3	(807)
4	(513)
5	(502)
↓	53.3 mm
↔	46.4 mm

No.44 4分



1	(328)
2	(079)
3	(807)
4	(513)
5	(502)
↓	52.3 mm
↔	40.7 mm

No.49 4分



1	(328)
2	(079)
3	(807)
4	(513)
5	(502)
↓	53.3 mm
↔	46.5 mm

No.35 3分



1	(328)
2	(079)
3	(807)
4	(513)
5	(502)
↓	53.9 mm
↔	23.8 mm

No.40 4分



1	(328)
2	(079)
3	(807)
4	(513)
5	(502)
↓	52.9 mm
↔	43.1 mm

No.45 3分



1	(328)
2	(079)
3	(807)
4	(513)
5	(502)
↓	52.6 mm
↔	35.0 mm

No.50 3分



1	(328)
2	(079)
3	(807)
4	(513)
5	(502)
↓	51.7 mm
↔	42.0 mm

No.36 3分



1	(328)
2	(079)
3	(807)
4	(513)
5	(502)
↓	52.6 mm
↔	30.1 mm

No.41 3分



1	(328)
2	(079)
3	(807)
4	(513)
5	(502)
↓	52.8 mm
↔	42.6 mm

No.46 3分



1	(328)
2	(079)
3	(807)
4	(513)
5	(502)
↓	53.0 mm
↔	42.0 mm

No.51 3分



1	(328)
2	(079)
3	(807)
4	(513)
5	(502)
↓	53.8 mm
↔	42.2 mm

No.37 4分



1	(328)
2	(079)
3	(807)
4	(513)
5	(502)
↓	52.4 mm
↔	43.4 mm

No.42 3分



1	(328)
2	(079)
3	(807)
4	(513)
5	(502)
↓	52.1 mm
↔	36.9 mm

No.47 3分



1	(328)
2	(079)
3	(807)
4	(513)
5	(502)
↓	52.5 mm
↔	42.8 mm

No.52 3分



1	(328)
2	(079)
3	(807)
4	(513)
5	(502)
↓	52.4 mm
↔	33.4 mm

No.53 2分



1	(804)
2	(612)
3	(079)
4	(807)
5	(513)
6	(502)
↓	34.4 mm
↔	22.7 mm

No.55



3分		
1	(804)	3 (079)
2	(612)	4 (807)
5	(513)	6 (502)
↓ 39.3 mm ↔ 75.4 mm		

No.57



6分			
1	(804)	7 (804)	13 (079)
2	(612)	8 (612)	14 (807)
3	(079)	9 (079)	15 (513)
4	(807)	10 (807)	16 (502)
5	(513)	11 (513)	
6	(502)	12 (502)	
↓ 27.9 mm ↔ 121.9 mm			

No.54 2分



1	(079)
2	(807)
3	(513)
4	(502)
↓	39.8 mm
↔	25.6 mm

No.56



6分			
1	(804)	5 (513)	9 (079)
2	(612)	6 (502)	10 (807)
3	(079)	7 (804)	11 (513)
4	(807)	8 (612)	12 (502)
↓ 23.4 mm ↔ 123.7 mm			



No. 58

11 分		
1 (079)	7 (513)	13 (079)
2 (807)	8 (502)	14 (807)
3 (513)	9 (079)	15 (513)
4 (502)	10 (807)	16 (502)
5 (079)	11 (513)	
6 (807)	12 (502)	
⇅ 103.6 mm ⇔ 94.9 mm		



No.60

4 分	
1 (513)	
2 (807)	
3 (513)	
4 (807)	
⇅ 106.7 mm	
⇔ 93.4 mm	



No.63

1 分	
1 (513)	
⇅ 147.2 mm	
⇔ 61.8 mm	



No.59

20 分		
1 (079)	17 (513)	33 (804)
2 (807)	18 (502)	34 (612)
3 (804)	19 (079)	35 (513)
4 (612)	20 (807)	36 (502)
5 (513)	21 (804)	37 (079)
6 (502)	22 (612)	38 (807)
7 (079)	23 (513)	39 (804)
8 (807)	24 (502)	40 (612)
9 (804)	25 (079)	41 (513)
10 (612)	26 (807)	42 (502)
11 (513)	27 (804)	43 (079)
12 (502)	28 (612)	44 (807)
13 (079)	29 (513)	45 (804)
14 (807)	30 (502)	46 (612)
15 (804)	31 (079)	47 (513)
16 (612)	32 (807)	48 (502)
⇅ 195.4 mm ⇔ 157.3 mm		



No.61

3 分	
1 (513)	
2 (807)	
3 (513)	
4 (807)	
⇅ 42.6 mm	
⇔ 142.0 mm	



No.62

11 分		
1 (513)	4 (807)	7 (513)
2 (807)	5 (513)	8 (807)
3 (513)	6 (807)	
⇅ 195.4 mm ⇔ 158.5 mm		



No.64

7 分		
1 (804)	9 (079)	17 (513)
2 (612)	10 (807)	18 (502)
3 (079)	11 (513)	19 (804)
4 (807)	12 (502)	20 (612)
5 (513)	13 (804)	21 (079)
6 (502)	14 (612)	22 (807)
7 (804)	15 (079)	23 (513)
8 (612)	16 (807)	24 (502)
⇅ 73.3 mm ⇔ 72.8 mm		

●ラインアルファベット



No.1

L: 13分	
S: 9分	
1	■ (005)
2	■ (807)
L:	↓ 125.1 mm
	↔ 103.3 mm
S:	↓ 95.9 mm
	↔ 79.1 mm



No.4

L: 14分	
S: 10分	
1	■ (005)
2	■ (807)
L:	↓ 124.8 mm
	↔ 95.8 mm
S:	↓ 95.8 mm
	↔ 73.8 mm



No.7

L: 12分	
S: 8分	
1	■ (005)
2	■ (807)
L:	↓ 125.0 mm
	↔ 87.6 mm
S:	↓ 95.8 mm
	↔ 67.2 mm



No.2

L: 13分	
S: 9分	
1	■ (005)
2	■ (807)
L:	↓ 124.8 mm
	↔ 86.6 mm
S:	↓ 95.7 mm
	↔ 66.4 mm



No.5

L: 14分	
S: 10分	
1	■ (005)
2	■ (807)
L:	↓ 124.8 mm
	↔ 87.8 mm
S:	↓ 95.8 mm
	↔ 67.4 mm

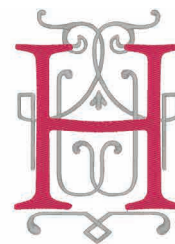

No.8

L: 15分	
S: 10分	
1	■ (005)
2	■ (807)
L:	↓ 125.0 mm
	↔ 89.8 mm
S:	↓ 95.7 mm
	↔ 68.8 mm

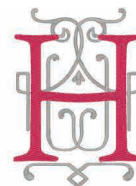

No.3

L: 11分	
S: 8分	
1	■ (005)
2	■ (807)
L:	↓ 124.8 mm
	↔ 85.6 mm
S:	↓ 95.8 mm
	↔ 65.8 mm



No.6

L: 13分	
S: 9分	
1	■ (005)
2	■ (807)
L:	↓ 124.8 mm
	↔ 80.8 mm
S:	↓ 95.8 mm
	↔ 61.8 mm



No.9

L: 7分	
S: 5分	
1	■ (005)
2	■ (807)
L:	↓ 124.9 mm
	↔ 66.0 mm
S:	↓ 95.8 mm
	↔ 50.6 mm



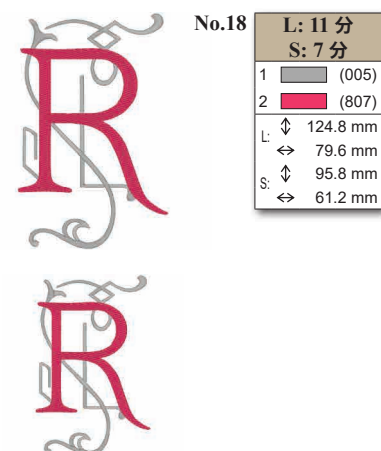
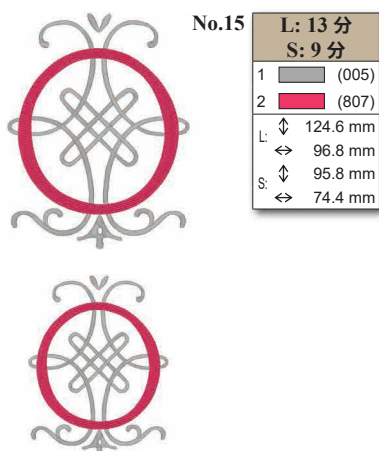
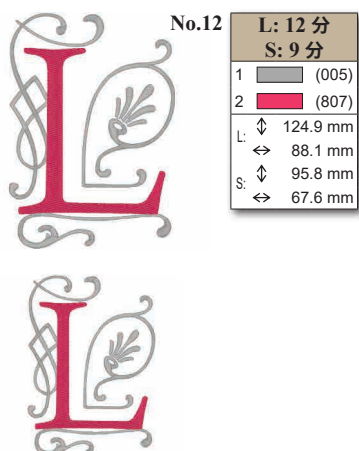
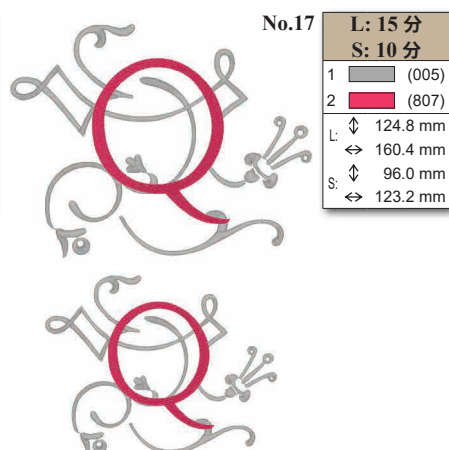
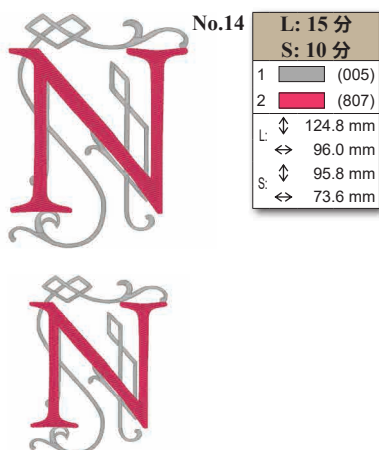
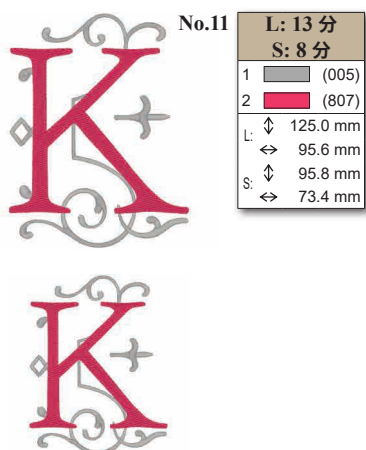
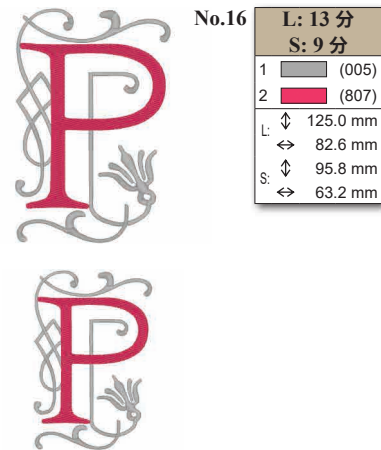
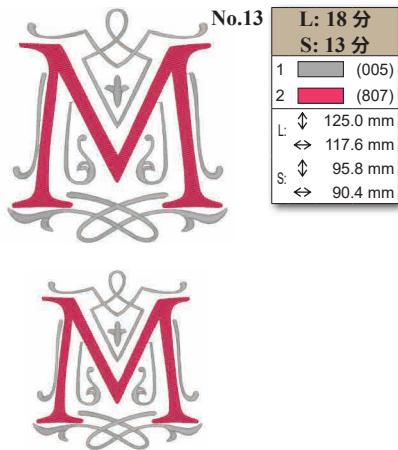
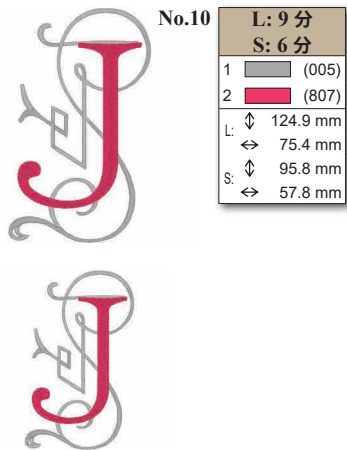

刺しゅう色替え表

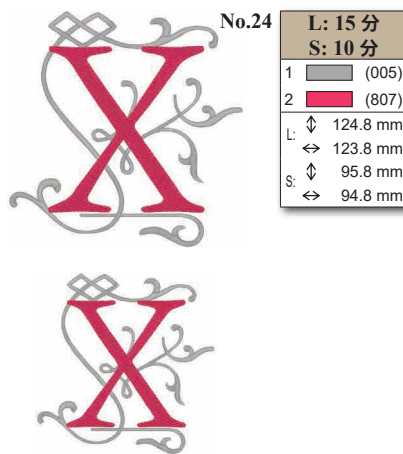
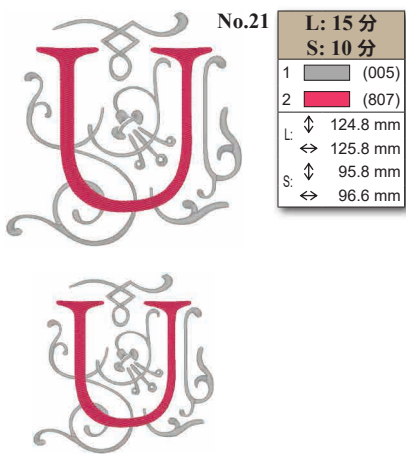
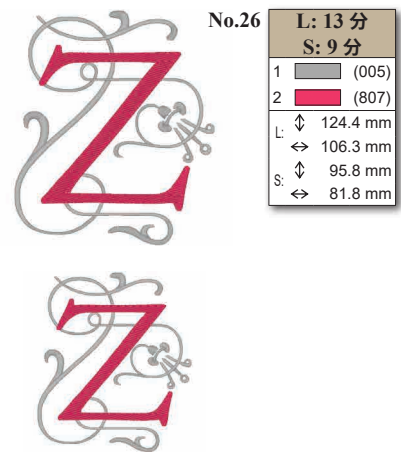
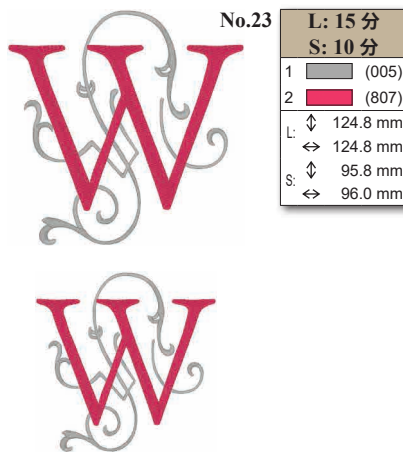
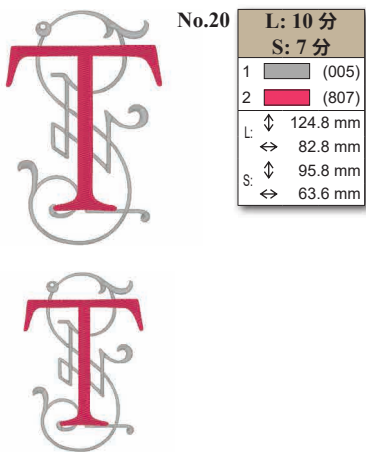
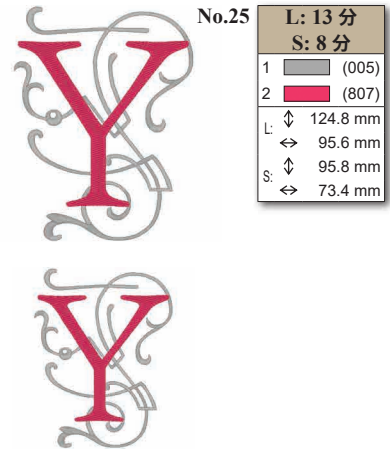
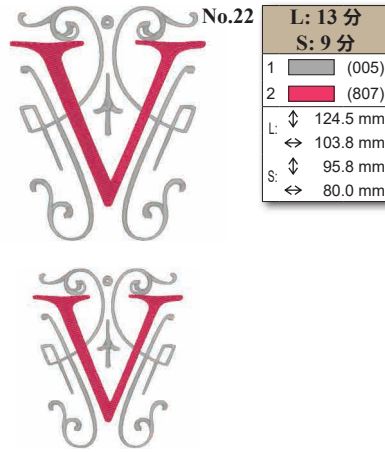
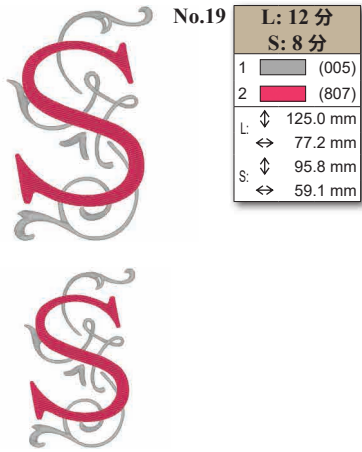

No.1 - No.26 は、Hang to Dry によるデザインを模様にしてあります。

● バインアルファベット



No.1 4分

1	(620)
2	(612)
↓	54.3 mm
⇔	82.8 mm

No.9 3分

1	(620)
2	(612)
↓	55.0 mm
⇔	68.3 mm

No.17 3分

1	(620)
2	(612)
↓	54.9 mm
⇔	83.5 mm

No.25 3分

1	(620)
2	(612)
↓	53.1 mm
⇔	65.9 mm

No.2 3分

1	(620)
2	(612)
↓	54.4 mm
⇔	72.6 mm

No.10 3分

1	(620)
2	(612)
↓	54.3 mm
⇔	71.0 mm

No.18 4分

1	(620)
2	(612)
↓	54.7 mm
⇔	81.5 mm

No.26 3分

1	(620)
2	(612)
↓	55.9 mm
⇔	70.0 mm

No.3 3分

1	(620)
2	(612)
↓	53.9 mm
⇔	73.3 mm

No.11 3分

1	(620)
2	(612)
↓	55.2 mm
⇔	85.3 mm

No.19 3分

1	(620)
2	(612)
↓	54.5 mm
⇔	73.8 mm

No.27 3分

1	(620)
2	(612)
↓	57.4 mm
⇔	57.7 mm

No.4 4分

1	(620)
2	(612)
↓	54.6 mm
⇔	80.0 mm

No.12 3分

1	(620)
2	(612)
↓	53.9 mm
⇔	75.0 mm

No.20 3分

1	(620)
2	(612)
↓	54.2 mm
⇔	73.2 mm

No.28

3分	
1	(620)
2	(612)
↓	31.5 mm
⇔	119.2 mm

No.5 3分

1	(620)
2	(612)
↓	55.0 mm
⇔	65.3 mm

No.13 4分

1	(620)
2	(612)
↓	54.1 mm
⇔	85.0 mm

No.21 3分

1	(620)
2	(612)
↓	53.6 mm
⇔	78.3 mm

No.29

2分	
1	(620)
2	(612)
↓	13.4 mm
⇔	195.4 mm

No.6 3分

1	(620)
2	(612)
↓	54.0 mm
⇔	78.8 mm

No.14 3分

1	(620)
2	(612)
↓	54.6 mm
⇔	84.8 mm

No.22 3分

1	(620)
2	(612)
↓	53.1 mm
⇔	70.9 mm

No.7 3分

1	(620)
2	(612)
↓	54.6 mm
⇔	70.4 mm

No.15 3分

1	(620)
2	(612)
↓	53.9 mm
⇔	78.7 mm

No.23 4分

1	(620)
2	(612)
↓	53.4 mm
⇔	82.6 mm

No.1 4分

1	(620)
2	(612)
↓	54.3 mm
⇔	82.8 mm

No.8 4分

1	(620)
2	(612)
↓	54.3 mm
⇔	83.3 mm

No.16 3分

1	(620)
2	(612)
↓	54.7 mm
⇔	67.2 mm

No.24 3分

1	(620)
2	(612)
↓	53.2 mm
⇔	83.4 mm

●アプリケアルファベット



※おおよそのサイズです。

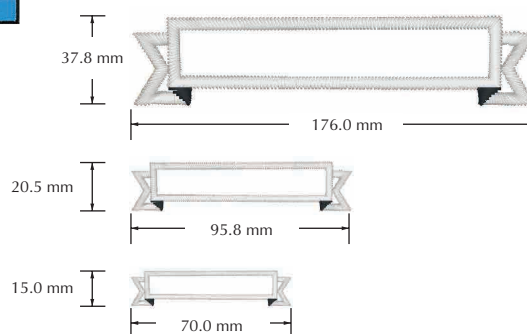
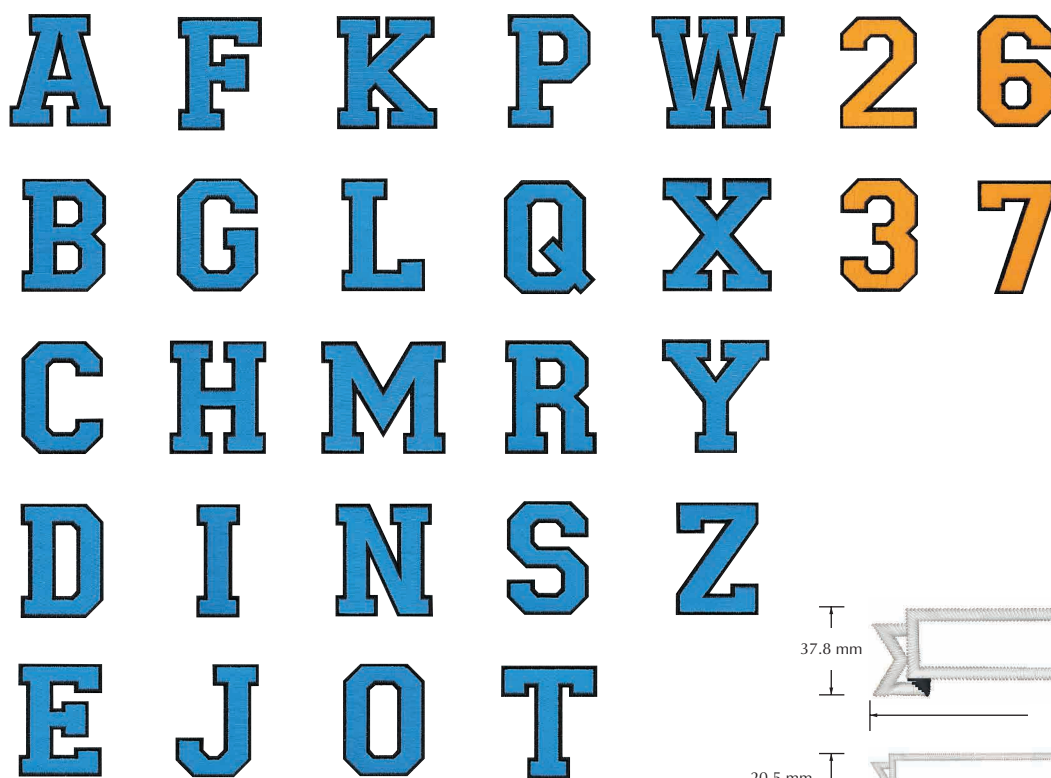
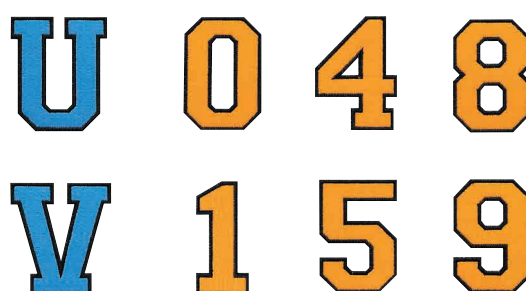

♥ アプリケの作り方については、ミシンの取扱説明書を参照してください。

●ギリシャ文字アップリケ



<p>No.1 3分</p> <p>1 (420) 2 (420) 3 (509) 4 (509) ↓ 77.8 mm ↔ 80.4 mm</p>	<p>No.7 5分</p> <p>1 (420) 2 (420) 3 (509) 4 (509) ↓ 75.9 mm ↔ 78.5 mm</p>	<p>No.13 4分</p> <p>1 (420) 2 (420) 3 (509) 4 (509) ↓ 78.3 mm ↔ 78.4 mm</p>	<p>No.19 3分</p> <p>1 (420) 2 (420) 3 (509) 4 (509) ↓ 76.1 mm ↔ 68.0 mm</p>
<p>No.2 4分</p> <p>1 (420) 2 (420) 3 (509) 4 (509) ↓ 76.0 mm ↔ 70.7 mm</p>	<p>No.8 5分</p> <p>1 (420) 2 (420) 3 (509) 4 (509) ↓ 80.2 mm ↔ 73.9 mm</p>	<p>No.14 5分</p> <p>1 (420) 2 (420) 3 (509) 4 (509) ↓ 76.1 mm ↔ 68.5 mm</p>	<p>No.20 3分</p> <p>1 (420) 2 (420) 3 (509) 4 (509) ↓ 75.9 mm ↔ 79.1 mm</p>
<p>No.3 3分</p> <p>1 (420) 2 (420) 3 (509) 4 (509) ↓ 76.0 mm ↔ 68.2 mm</p>	<p>No.9 2分</p> <p>1 (420) 2 (420) 3 (509) 4 (509) ↓ 76.0 mm ↔ 38.1 mm</p>	<p>No.15 3分</p> <p>1 (420) 2 (420) 3 (509) 4 (509) ↓ 80.3 mm ↔ 73.9 mm</p>	<p>No.21 5分</p> <p>1 (420) 2 (420) 3 (509) 4 (509) ↓ 75.9 mm ↔ 78.0 mm</p>
<p>No.4 3分</p> <p>1 (420) 2 (420) 3 (509) 4 (509) ↓ 77.7 mm ↔ 70.0 mm</p>	<p>No.10 4分</p> <p>1 (420) 2 (420) 3 (509) 4 (509) ↓ 76.1 mm ↔ 80.5 mm</p>	<p>No.16 4分</p> <p>1 (420) 2 (420) 3 (509) 4 (509) ↓ 75.9 mm ↔ 82.6 mm</p>	<p>No.22 4分</p> <p>1 (420) 2 (420) 3 (509) 4 (509) ↓ 76.0 mm ↔ 80.8 mm</p>
<p>No.5 4分</p> <p>1 (420) 2 (420) 3 (509) 4 (509) ↓ 76.1 mm ↔ 69.8 mm</p>	<p>No.11 3分</p> <p>1 (420) 2 (420) 3 (509) 4 (509) ↓ 78.0 mm ↔ 76.0 mm</p>	<p>No.17 3分</p> <p>1 (420) 2 (420) 3 (509) 4 (509) ↓ 76.0 mm ↔ 62.0 mm</p>	<p>No.23 4分</p> <p>1 (420) 2 (420) 3 (509) 4 (509) ↓ 76.0 mm ↔ 86.7 mm</p>
<p>No.6 3分</p> <p>1 (420) 2 (420) 3 (509) 4 (509) ↓ 76.0 mm ↔ 67.4 mm</p>	<p>No.12 5分</p> <p>1 (420) 2 (420) 3 (509) 4 (509) ↓ 76.0 mm ↔ 95.3 mm</p>	<p>No.18 4分</p> <p>1 (420) 2 (420) 3 (509) 4 (509) ↓ 76.0 mm ↔ 69.0 mm</p>	<p>No.24 5分</p> <p>1 (420) 2 (420) 3 (509) 4 (509) ↓ 78.0 mm ↔ 74.1 mm</p>

♥ アップリケの作り方については、ミシンの取扱説明書を参照してください。

❖ モノグラム模様

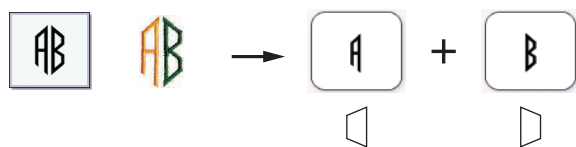
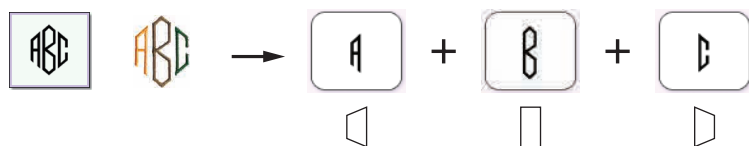

● モノグラム模様枠

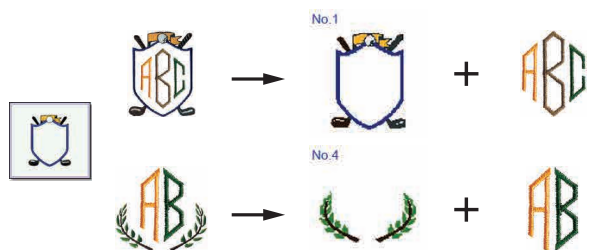

❁ モノグラム模様枠



No.1

L: 5分
M: 3分
S: 2分
1 (001)
2 (058)
3 (208)
4 (707)
5 (007)
L: ↓ 94.4 mm
↔ 73.6 mm
M: ↓ 64.1 mm
↔ 50.1 mm
S: ↓ 40.9 mm
↔ 31.2 mm

No.4

L: 2分
M: 1分
S: 1分
1 (515)
2 (058)
L: ↓ 48.4 mm
↔ 92.5 mm
M: ↓ 31.2 mm
↔ 59.5 mm
S: ↓ 19.1 mm
↔ 36.4 mm

No.7

L: 2分
M: 1分
S: 1分
1 (214)
2 (843)
L: ↓ 84.8 mm
↔ 84.8 mm
M: ↓ 55.0 mm
↔ 54.9 mm
S: ↓ 33.9 mm
↔ 33.9 mm

No.2

L: 5分
M: 3分
S: 2分
1 (001)
2 (513)
3 (208)
4 (007)
5 (900)
L: ↓ 90.1 mm
↔ 81.6 mm
M: ↓ 60.2 mm
↔ 54.9 mm
S: ↓ 38.8 mm
↔ 36.1 mm

No.5

L: 1分
M: 1分
S: 1分
1 (205)
2 (085)
3 (612)
4 (800)
L: ↓ 92.5 mm
↔ 78.9 mm
M: ↓ 59.6 mm
↔ 50.9 mm
S: ↓ 34.9 mm
↔ 29.7 mm

No.8

L: 2分
M: 1分
S: 1分
1 (507)
2 (800)
L: ↓ 94.9 mm
↔ 94.4 mm
M: ↓ 63.6 mm
↔ 63.9 mm
S: ↓ 39.9 mm
↔ 40.2 mm

No.3

L: 3分
M: 2分
S: 1分
1 (323)
L: ↓ 93.8 mm
↔ 64.5 mm
M: ↓ 61.4 mm
↔ 42.6 mm
S: ↓ 40.3 mm
↔ 27.5 mm

No.6

L: 3分
M: 1分
S: 1分
1 (328)
L: ↓ 77.5 mm
↔ 78.2 mm
M: ↓ 50.0 mm
↔ 50.4 mm
S: ↓ 29.7 mm
↔ 29.9 mm

No.9

L: 3分
M: 1分
S: 1分
1 (900)
2 (515)
3 (214)
L: ↓ 94.6 mm
↔ 72.3 mm
M: ↓ 59.5 mm
↔ 46.0 mm
S: ↓ 37.2 mm
↔ 28.8 mm

刺しゅう色替え表

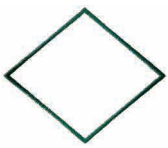

No.10



L: 2分	
M: 1分	
S: 1分	
1	 (534)
L:	↕ 83.4 mm
	↔ 98.7 mm
M:	↕ 56.1 mm
	↔ 66.8 mm
S:	↕ 35.1 mm
	↔ 41.8 mm

No.12



L: 1分	
M: 1分	
S: 1分	
1	 (070)
2	 (612)
L:	↕ 22.7 mm
	↔ 90.0 mm
M:	↕ 14.5 mm
	↔ 57.4 mm
S:	↕ 8.9 mm
	↔ 34.6 mm

No.14



L: 1分	
M: 1分	
S: 1分	
1	 (800)
L:	↕ 24.4 mm
	↔ 88.1 mm
M:	↕ 15.1 mm
	↔ 56.7 mm
S:	↕ 8.4 mm
	↔ 38.9 mm

No.11



L: 1分	
M: 1分	
S: 1分	
1	 (620)
L:	↕ 25.2 mm
	↔ 89.4 mm
M:	↕ 16.8 mm
	↔ 57.4 mm
S:	↕ 9.1 mm
	↔ 34.0 mm



No.13



L: 1分	
M: 1分	
S: 1分	
1	 (208)
L:	↕ 28.3 mm
	↔ 91.4 mm
M:	↕ 18.4 mm
	↔ 59.0 mm
S:	↕ 11.4 mm
	↔ 36.1 mm

No.15



L: 2分	
M: 1分	
S: 1分	
1	 (214)
2	 (058)
L:	↕ 24.3 mm
	↔ 54.4 mm
M:	↕ 15.5 mm
	↔ 34.7 mm
S:	↕ 9.3 mm
	↔ 20.8 mm

模様組み合わせ例

※ここでサンプルとして掲載されている模様はイメージ画像です。実際にミシンで縫製したときの仕上がりとは異なります。



No.3 + 



No.4 + 



No.5 =  (900)



No.3 + No.5 × 2



No.16 × 2 + No.17 × 2



No.8 + No.9 × 2



No.3 × 2

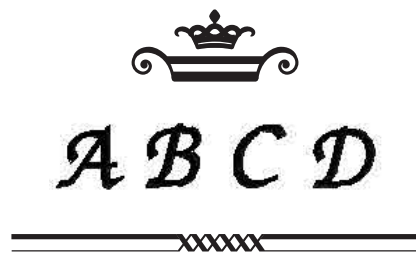

No.14 + No.15



No.12 × 2

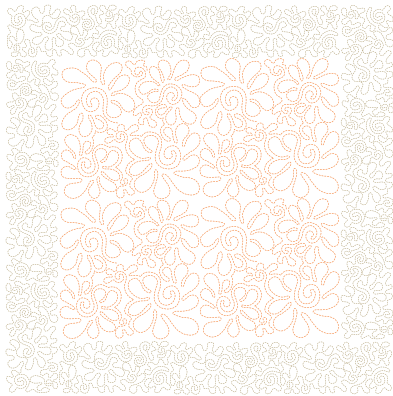

No.2 × 4 + No.14 × 12

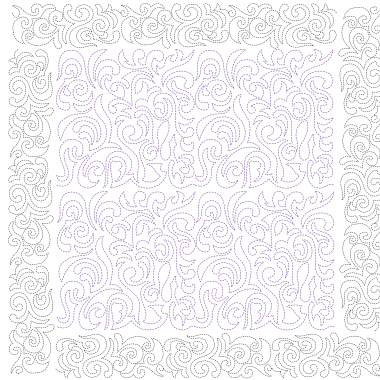

No.8 × 4 + No.16 × 12

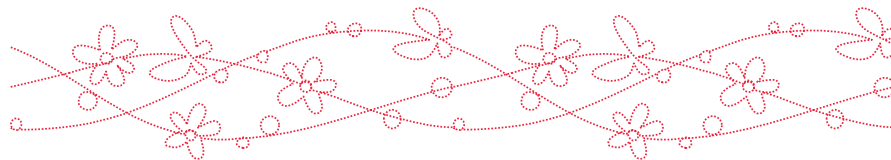

No.17 × 2



No.2 + No.27 × 2



No.6 + No.10 + No.19



No.2 + No.28 × 2

3D 刺しゅうの作り方

刺しゅう用ウレタンフォームを使用することで、立体的に刺しゅうすることができます。
3D刺しゅうフォントの刺しゅう方法については、取扱説明書をご覧ください。

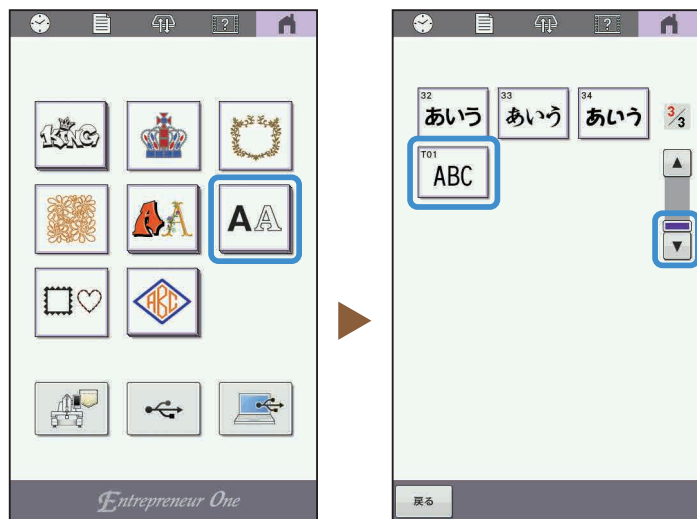





























使い方動画



<https://s.brother/cvcac/>

※帽子に刺しゅうするときは、帽子枠F(別売)のご使用をおすすめします。詳細はブラザーのサポートサイト
をご確認ください。<https://s.brother/cocac/>

フォント名一覧

1		Künstlerschreibschrift	19		Los Angeles
2		Block 01	20		Saipan
3		Serif 01	21		Gothic 01
4		Brussels Demi Outline	22		Bayern Book
5		Tennessee ExtraBold	23		Florida Medium
6		Brussels Light	24		Lillehammer
7		Serif 02	25		Dalliance Roman
8		Calgary MediumItalic	26		Helsinki Nallow S**
9		Maryland	27		Riesa S**
10		Vermont	28		Germany S**
11		Dalliance Script	29		Script 01 SR**
12		Sicilia Light Italic (Sicilia)	30		Block 01**
13		Luedickital	31		Utah Bold Cyrillic
14		Toms Handwritten	32		PC Tennessee Bold Cyrillic
15		Bergen	33		日本語 1
16		Tirol	34		日本語 2
17		Istanbul	35		日本語 3
18		San Diego	36		Letter Gothic Bold

※ミニサイズ文字

882-T52



D02UME-001