



Online User's Guide

SP-1

Instructional Videos



<https://s.brother/sublpbsc2faq8>

Table of Contents

| | |
|---|-----------|
| Before You Use Your Machine | 1 |
| Definitions of Notes | 2 |
| Notice - Disclaimer of Warranties (USA and Canada) | 3 |
| Trademarks | 4 |
| Open Source Licensing Remarks | 5 |
| Copyright and License | 6 |
| Important Notes | 7 |
| Introduction to Your Machine | 8 |
| Before Using Your Machine | 9 |
| Control Panel Overview | 10 |
| Touchscreen LCD Overview | 11 |
| Settings Screen Overview | 14 |
| Enter Text on Your Brother Machine | 15 |
| Access Brother Utilities (Windows) | 16 |
| Uninstall the Brother Software and Drivers (Windows) | 17 |
| USB / Ethernet Port Locations on Your Brother Machine | 18 |
| Paper Handling | 19 |
| Load Paper | 20 |
| Load Paper in the Paper Tray | 21 |
| Load Paper in the Manual Feed Slot | 28 |
| Unprintable Area | 31 |
| Paper Settings | 32 |
| Acceptable Print Media | 35 |
| Print | 40 |
| Print from Your Computer (Windows) | 41 |
| Print a Document (Windows) | 42 |
| Cancel a Print Job (Windows) | 43 |
| Print a Color Document in Grayscale (Windows) | 44 |
| Prevent Smudged Printouts and Paper Jams (Windows) | 45 |
| Use a Print Profile (Windows) | 46 |
| Change the Default Print Settings (Windows) | 49 |
| Print Settings (Windows) | 50 |
| Print from Your Computer (Mac) | 54 |
| Print from Your Mobile Device | 55 |
| Network | 56 |
| Supported Basic Network Features | 57 |
| Configure Network Settings | 58 |
| Configure Network Settings Using the Control Panel | 59 |
| Wireless Network Settings | 60 |
| Use the Wireless Network | 61 |
| Use Wi-Fi Direct® | 73 |
| Enable/Disable Wireless LAN | 77 |
| Print the WLAN Report | 78 |
| Network Features | 81 |
| Print the Network Configuration Report | 82 |
| Reset the Network Settings to Factory Default | 83 |

| | |
|---|------------|
| Security | 84 |
| Before Using Network Security Features | 85 |
| Configure Certificates for Device Security | 86 |
| Supported Security Certificate Features | 87 |
| Step by Step Guide for Creating and Installing a Certificate | 88 |
| Create a Self-signed Certificate | 89 |
| Create CSR and Install a Certificate from a Certificate Authority (CA) | 90 |
| Import and Export the Certificate and Private Key | 94 |
| Import and Export a CA Certificate | 97 |
| Manage Multiple Certificates | 100 |
| Use SSL/TLS | 101 |
| Introduction to SSL/TLS | 102 |
| Manage Your Network Machine Securely Using SSL/TLS | 105 |
| Print Documents Securely Using SSL/TLS | 109 |
| Use SNMPv3 | 111 |
| Manage Your Network Machine Securely Using SNMPv3 | 112 |
| Use IPsec..... | 113 |
| Introduction to IPsec | 114 |
| Configure IPsec Using Web Based Management..... | 115 |
| Configure an IPsec Address Template Using Web Based Management..... | 116 |
| Configure an IPsec Template Using Web Based Management..... | 118 |
| Use IEEE 802.1x Authentication for a Wired or a Wireless Network..... | 127 |
| What Is IEEE 802.1x Authentication? | 128 |
| Configure IEEE 802.1x Authentication for a Wired or a Wireless Network Using Web Based Management (Web Browser) | 129 |
| IEEE 802.1x Authentication Methods..... | 131 |
| Send an Email Securely..... | 132 |
| Configure Email Sending Using Web Based Management..... | 133 |
| Send an Email with User Authentication | 134 |
| Send an Email Securely Using SSL/TLS | 135 |
| Mobile Connect..... | 136 |
| Brother Artspira..... | 137 |
| Brother Artspira Overview | 138 |
| Connect Your Mobile Device to Your Machine Using Brother Artspira | 139 |
| Print a Design Using Brother Artspira | 140 |
| Print an Image Saved On Your Mobile Device Using Brother Artspira | 141 |
| AirPrint..... | 142 |
| AirPrint Overview | 143 |
| Before Using AirPrint (macOS) | 144 |
| Print Using AirPrint..... | 145 |
| Troubleshooting | 148 |
| Error and Maintenance Messages | 149 |
| Printer Jam or Paper Jam..... | 154 |
| Paper is Jammed Inside and in the Front of the Machine (Jam Inside/ Front)..... | 155 |
| Paper is Jammed in the Front of the Machine (Jam Front)..... | 161 |
| Paper is Jammed in the Back of the Machine (Jam Rear)..... | 165 |
| If You Are Having Difficulty with Your Machine..... | 167 |
| Paper Handling and Printing Problems | 168 |
| Other Problems | 172 |





| | |
|--|------------|
| Network Problems | 173 |
| AirPrint Problems | 180 |
| Artspira Problems | 181 |
| Check the Machine Information | 182 |
| Reset Your Machine | 183 |
| Reset Functions Overview | 184 |
| Routine Maintenance | 185 |
| Disposing of Used Consumables | 186 |
| Replace the Ink Cartridges | 187 |
| Clean Your Brother Machine..... | 190 |
| Clean the Print Head from Your Brother Machine..... | 191 |
| Clean the Print Head Using Web Based Management | 192 |
| Clean the Print Head from Your Computer (Windows) | 193 |
| Clean the Machine's LCD..... | 194 |
| Clean the Outside of the Machine | 195 |
| Clean the Machine's Printer Platen | 197 |
| Clean the Paper Feed Rollers | 198 |
| Clean the Base Pad | 200 |
| Clean the Paper Pick-up Rollers | 201 |
| Check Your Brother Machine..... | 203 |
| Check the Print Quality | 204 |
| Check the Ink Volume | 206 |
| Monitor Machine Status from Your Computer (Windows)..... | 207 |
| Correct the Paper Feed to Clear Vertical Lines | 212 |
| Change the Print Options to Improve Your Print Results..... | 213 |
| Pack and Ship Your Machine..... | 214 |
| Machine Settings..... | 216 |
| Change Machine Settings from the Control Panel..... | 217 |
| In the Event of Power Failure (Memory Storage)..... | 218 |
| General Settings | 219 |
| Print Reports | 230 |
| Settings and Features Tables | 233 |
| Change Machine Settings Using Web Based Management..... | 241 |
| What is Web Based Management?..... | 242 |
| Access Web Based Management | 243 |
| Set or Change a Login Password for Web Based Management..... | 245 |
| Appendix..... | 246 |
| Specifications..... | 247 |
| Supply Specifications..... | 250 |
| Brother Help and Customer Support..... | 251 |

Before You Use Your Machine

- [Definitions of Notes](#)
- [Notice - Disclaimer of Warranties \(USA and Canada\)](#)
- [Trademarks](#)
- [Open Source Licensing Remarks](#)
- [Copyright and License](#)
- [Important Notes](#)

Definitions of Notes

We use the following symbols and conventions throughout this User's Guide:

| | |
|--|---|
|  WARNING | WARNING indicates a potentially hazardous situation which, if not avoided, could result in death or serious injuries. |
|  CAUTION | CAUTION indicates a potentially hazardous situation which, if not avoided, may result in minor or moderate injuries. |
| IMPORTANT | IMPORTANT indicates a potentially hazardous situation which, if not avoided, may result in damage to property or loss of product functionality. |
| NOTE | NOTE specifies the operating environment, conditions for installation, or special conditions of use. |
|  | Tips icons indicate helpful hints and supplementary information. |
|  | Electrical Hazard icons alert you to possible electrical shock. |
| Bold | Bold style identifies buttons on the machine's control panel or computer screen. |
| <i>Italics</i> | Italicized style emphasizes an important point or refers you to a related topic. |
| Courier New | Courier New font identifies messages shown on the machine's LCD. |



Related Information

- [Before You Use Your Machine](#)
-

Notice - Disclaimer of Warranties (USA and Canada)

BROTHER'S LICENSOR(S), AND THEIR DIRECTORS, OFFICERS, EMPLOYEES OR AGENTS (COLLECTIVELY BROTHER'S LICENSOR) MAKE NO WARRANTIES, EXPRESS OR IMPLIED, INCLUDING WITHOUT LIMITATION THE IMPLIED WARRANTIES OF MERCHANTABILITY AND FITNESS FOR A PARTICULAR PURPOSE, REGARDING THE SOFTWARE. BROTHER'S LICENSOR(S) DOES NOT WARRANT, GUARANTEE OR MAKE ANY REPRESENTATIONS REGARDING THE USE OR THE RESULTS OF THE USE OF THE SOFTWARE IN TERMS OF ITS CORRECTNESS, ACCURACY, RELIABILITY, CURRENTNESS OR OTHERWISE. THE ENTIRE RISK AS TO THE RESULTS AND PERFORMANCE OF THE SOFTWARE IS ASSUMED BY YOU. THE EXCLUSION OF IMPLIED WARRANTIES IS NOT PERMITTED BY SOME STATES IN THE USA AND SOME PROVINCES IN CANADA. THE ABOVE EXCLUSION MAY NOT APPLY TO YOU.

IN NO EVENT WILL BROTHER'S LICENSOR(S) BE LIABLE TO YOU FOR ANY CONSEQUENTIAL, INCIDENTAL OR INDIRECT DAMAGES (INCLUDING DAMAGES FOR LOSS OF BUSINESS PROFITS, BUSINESS INTERRUPTION, LOSS OF BUSINESS INFORMATION, AND THE LIKE) ARISING OUT OF THE USE OR INABILITY TO USE THE SOFTWARE EVEN IF BROTHER'S LICENSOR HAS BEEN ADVISED OF THE POSSIBILITY OF SUCH DAMAGES. BECAUSE SOME STATES IN THE USA AND SOME PROVINCES IN CANADA DO NOT ALLOW THE EXCLUSION OR LIMITATION OF LIABILITY FOR CONSEQUENTIAL OR INCIDENTAL DAMAGES, THE ABOVE LIMITATIONS MAY NOT APPLY TO YOU. IN ANY EVENT BROTHER'S LICENSOR'S LIABILITY TO YOU FOR ACTUAL DAMAGES FROM ANY CAUSE WHATSOEVER, AND REGARDLESS OF THE FORM OF THE ACTION (WHETHER IN CONTRACT, TORT (INCLUDING NEGLIGENCE), PRODUCT LIABILITY OR OTHERWISE), WILL BE LIMITED TO \$50.



Related Information

- [Before You Use Your Machine](#)

Trademarks

Apple, App Store, AirPrint, Mac, iPad, iPhone, iPod touch, macOS, iPadOS and Safari are trademarks of Apple Inc., registered in the United States and other countries.

Nuance and PaperPort are trademarks or registered trademarks of Nuance Communications, Inc. or its affiliates in the United States and/or other countries.

Wi-Fi®, Wi-Fi Alliance® and Wi-Fi Direct® are registered trademarks of Wi-Fi Alliance®.

WPA™, WPA2™, and Wi-Fi Protected Setup™ are trademarks of Wi-Fi Alliance®.

Android, Google Drive, Google Play and Google Chrome are trademarks of Google LLC.

The Bluetooth® word mark is a registered trademark owned by Bluetooth SIG, Inc. and any use of such marks by Brother Industries, Ltd. is under license. Other trademarks and trade names are those of their respective owners.

Each company whose software title is mentioned in this manual has a Software License Agreement specific to its proprietary programs.

Software Trademarks

Reliance™ is a trademark of Datalight, Inc.

Reliance Nitro™ is a trademark of Datalight, Inc.

Datalight® is a registered trademark of Datalight, Inc.

Any trade names and product names of companies appearing on Brother products, related documents and any other materials are all trademarks or registered trademarks of those respective companies.



Related Information

- [Before You Use Your Machine](#)

Open Source Licensing Remarks

This product includes open-source software.

To view Open Source Licensing Remarks and Copyright Information, go to your model's **Manuals** page at <https://s.brother/cm2ab/>.



Related Information

- [Before You Use Your Machine](#)
-

Copyright and License

©2023 Brother Industries, Ltd. All rights reserved.

This product includes software developed by the following vendors:

This product includes the “KASAGO TCP/IP” software developed by ZUKEN ELMIC, Inc.

Copyright 1989-2020 Datalight, Inc., All Rights Reserved.



Related Information

- [Before You Use Your Machine](#)

Important Notes

- Check <https://s.brother/ca2ab/> for Brother driver and software updates.
- To keep your machine's performance up to date, check <https://s.brother/ca2ab/> for the latest firmware upgrade. Otherwise, some of your machine's functions may not be available.
- Do not use this product outside the country of purchase as it may violate the wireless telecommunication and power regulations of that country.
- When replacing or disposing of your machine, Brother strongly recommends resetting it to its factory settings to remove all personal information.
- Windows 10 in this document represents Windows 10 Home, Windows 10 Pro, Windows 10 Education and Windows 10 Enterprise.
- The screens in this User's Guide are for illustration purposes only and may differ from the actual screens.
- Unless otherwise specified, the screens in this manual are from Windows 10 and macOS v11.x. Screens on your computer may vary depending on your operating system.
- The contents of this guide and the specifications of this product are subject to change without notice.
- Not all features are available in countries subject to applicable export restrictions.



Related Information

- [Before You Use Your Machine](#)

Related Topics:

- [Reset Your Machine](#)
-

Introduction to Your Machine

- [Before Using Your Machine](#)
- [Control Panel Overview](#)
- [Touchscreen LCD Overview](#)
- [Settings Screen Overview](#)
- [Enter Text on Your Brother Machine](#)
- [Access Brother Utilities \(Windows\)](#)
- [USB / Ethernet Port Locations on Your Brother Machine](#)

Before Using Your Machine

Before attempting any printing operation, confirm the following:

- Make sure you have installed the correct software and drivers for your machine.
- For USB or network cable users: Make sure the interface cable is physically secure.

Selecting the correct type of paper

For high quality printing, it is important to select the correct type of paper. Be sure to read the information about acceptable paper before buying paper, and to determine the printable area depending on the settings in the printer driver or in the application you use to print.

Firewall (Windows)

If your computer is protected by a firewall and you are unable to print to a network printer, you may need to configure the firewall settings. If you are using the Windows Firewall and you installed the drivers using the steps in the installer, the necessary firewall settings have been already set. If you are using any other personal firewall software, see the User's Guide for your software or contact the software manufacturer.

What is sublimation printing?

This Sublimation Printer uses Sublimation Ink to print onto Sublimation Paper.

Sublimation printing is a process that involves printing a design onto a specific type of coated paper, then transferring that image onto another material (usually polyester) with a heat press.

Use a heat press machine suitable for the material you are using.



- When transferring the image to a mug, use only a polymer-coated mug, avoid transferring the image to any area that might come in contact with the mouth or lips, and make sure to follow the sublimate instructions correctly. If sublimation transfer is not performed correctly, the mug may not be suitable for drinking.
 - Although it is possible to transfer a sublimation image onto polymer-coated dishes, use the dishes only for artwork and not for serving food. DO NOT eat from dishes after transferring images onto them.
 - Do not sublimate onto non-polymer-coated mugs, bottles, plates, other containers, tableware, etc.
 - Sublimate transfer conditions may depend on the heat press machine and materials used. For more information, refer to the heat press machine's or material's user's guides.
 - Do not use an iron on sublimated fabric, or put the fabric in a clothes dryer. Ink may fade or may transfer to other fabrics.
-

Refer to the "Let's get started !" label (2) for sublimation printing overview.

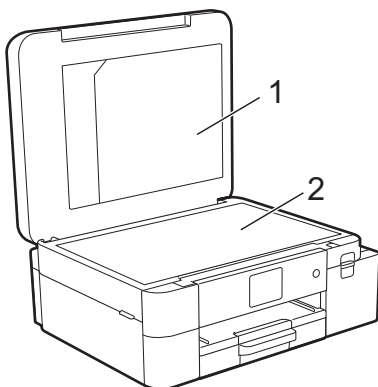

1. Document File Folder
2. "Let's get started !" label



Use the Document File Folder (1) for storing the manuals.



Related Information

- [Introduction to Your Machine](#)
-

Control Panel Overview

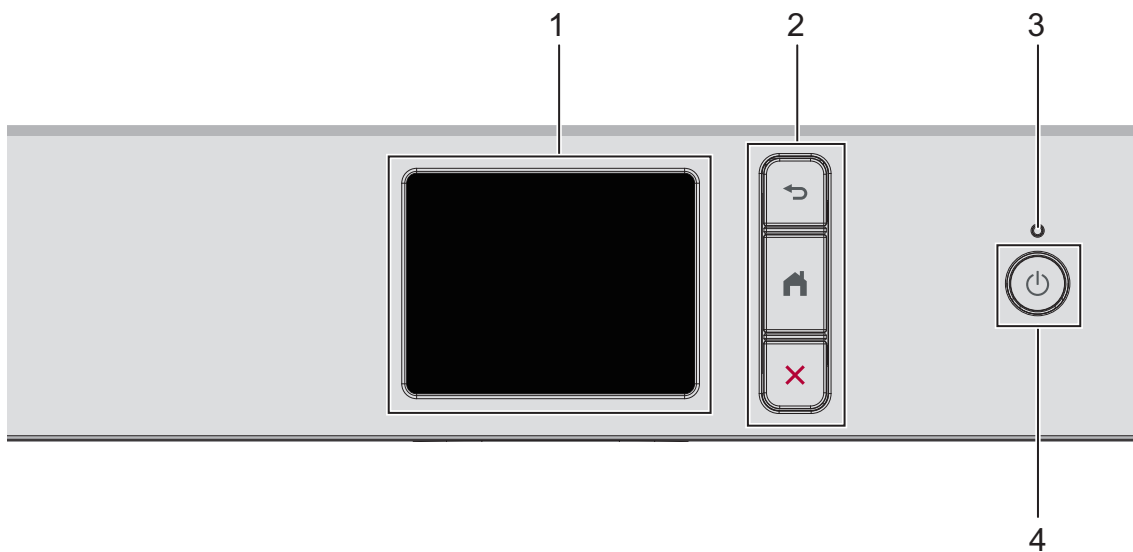

1. Touchscreen Liquid Crystal Display (LCD)

Access menus and options by pressing them on the touchscreen.

2. Menu Buttons

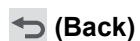

Press to go back to the previous menu.

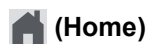

Press to return to the Home screen.



Press to cancel an operation.

3. LED Power Indicator

The LED lights up depending on the machine's power status.

When the machine is in Sleep Mode, the LED blinks.

4. Power On/Off

Press  to turn on the machine.

Press and hold  to turn off the machine. The touchscreen displays [Shutting Down] and stays on for a few seconds before turning itself off.

If you turn off the machine using , it will still clean the print head periodically to maintain print quality.



To prolong print head life, provide better ink efficiency, and maintain print quality, keep your machine connected to a power source at all times.

Related Information

- [Introduction to Your Machine](#)

Touchscreen LCD Overview

Using your finger, press ◀▶ or ▲▼ on the LCD to display and access the machine options. From the Home screens, you can access the various settings.

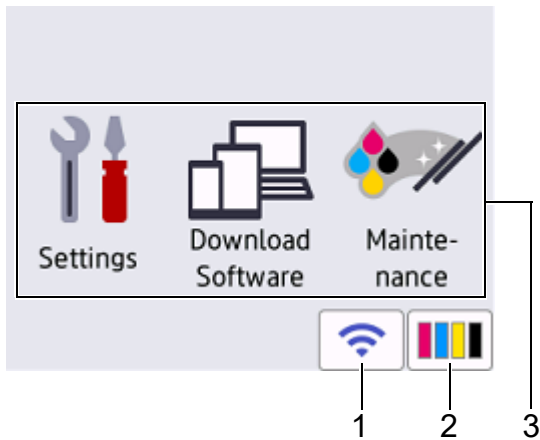

Home Screen



This screen shows the machine's status when the machine is idle. When displayed, it indicates that your machine is ready for the next command.

1. **Wireless Status**

Each icon in the following table shows the wireless network status:

| | |
|---|---|
|  | <ul style="list-style-type: none">Your machine is not connected to the wireless access point/router. Press this button to configure wireless settings. For more detailed information, see the <i>Quick Setup Guide</i>.The wireless setting is disabled. |
|  | The wireless network is connected. A three-level indicator in each of the Home screens displays the current wireless signal strength. |
|  | The wireless access point/router cannot be detected. |



You can configure wireless settings by pressing the Wireless Status button.

2. **[Ink]**

Displays the approximate available ink volume. Press to access the [Ink] menu.

When an ink cartridge is near the end of its life or having a problem, an error icon is displayed on the ink color indicator.

3. **Modes:**

Press to switch to each mode.

[Settings] / [Download Software] / [Maintenance]

4. Information icon

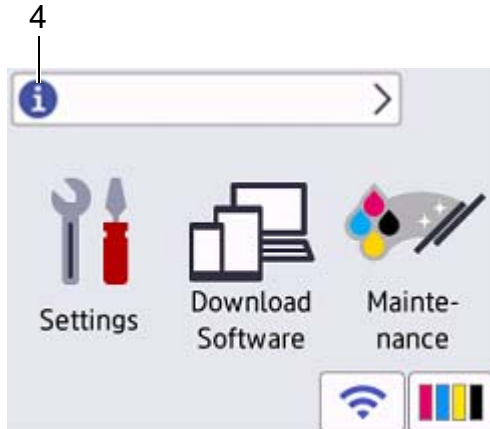

New information from Brother appears in the information bar when [Firmware Auto Check] is set to [On]. (An internet connection is needed, and data rates may apply.)

Press **i** to view the details.

5. Warning icon

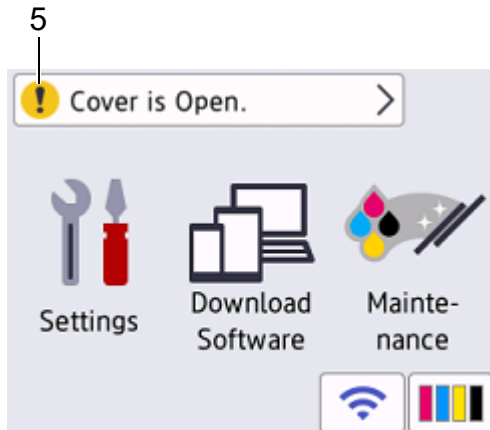

The warning icon **!** appears when there is an error or maintenance message; press **!** to view the details, and then press **X** to return to the Home screen.

IMPORTANT

DO NOT press the LCD with a sharp object such as a pen or stylus. It may damage the machine.

NOTE

DO NOT touch the LCD immediately after plugging in the power cord or turning on the machine. Doing this may cause an error.



This product adopts the font of ARPHIC TECHNOLOGY CO., LTD.



Related Information

- [Introduction to Your Machine](#)

Related Topics:

- [Check the Ink Volume](#)
 - [Settings Screen Overview](#)
 - [Error and Maintenance Messages](#)
-

Settings Screen Overview

The touchscreen shows the machine's status when you press  [Settings].
Use the Settings menu to access all of your Brother machine's settings.

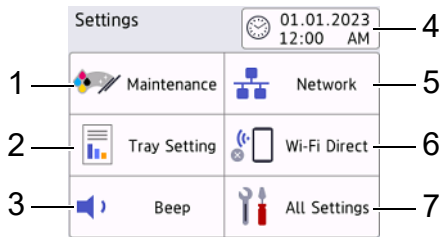

1. [Maintenance]

Press to access the following menus:

- [Improve Print Quality]
- [Print Head Cleaning]
- [Ink Volume]
- [Ink Cartridge Model]
- [Print Options]
- [Ink Cartridge Check]

2. [Tray Setting]

Press to access the [Tray Setting] menu.

Use these options to change the paper size.

3. [Beep]

Press to adjust machine's volume.

4. [Date & Time]

Displays the date and time.

Press to access the [Date & Time] menu.

5. [Network]

Press to set up a network connection.

If you are using a wireless connection, a three-level indicator  on the screen displays the current wireless signal strength.

6. [Wi-Fi Direct]

Press to set up a Wi-Fi Direct network connection.

7. [All Settings]

Press to access a menu of all of your machine's settings.

Related Information

- [Introduction to Your Machine](#)

Related Topics:



- [Touchscreen LCD Overview](#)
 - [Check the Ink Volume](#)
-

Enter Text on Your Brother Machine

- The characters that are available may differ depending on your country.
- For touchscreen models, the keyboard layout may differ depending on the function you are setting.

When you need to enter text on your Brother machine, a keyboard will appear on the touchscreen.





- Press  to cycle between letters, numbers and special characters.
- Press  to cycle between lowercase and uppercase letters.
- To move the cursor to the left or right, press ◀ or ▶.

Inserting spaces

- To enter a space, press [Space]. Or, you can press ▶ to move the cursor.

Making corrections



- If you entered an incorrect character and want to change it, press ◀ or ▶ to highlight the incorrect character. Press , and then enter the correct character.
- To insert a character, press ◀ or ▶ to move the cursor to the correct place, and then enter the character.
- Press  for each character you want to erase, or press and hold  to erase all the characters.

Related Information

- [Introduction to Your Machine](#)
-

Access Brother Utilities (Windows)

Brother Utilities is an application launcher that offers convenient access to all Brother applications installed on your computer.

1. Do one of the following:
 - Windows 11
Click  > **All apps** > **Brother** > **Brother Utilities**.
 - Windows 10
Click  > **Brother** > **Brother Utilities**.
2. Select your machine.

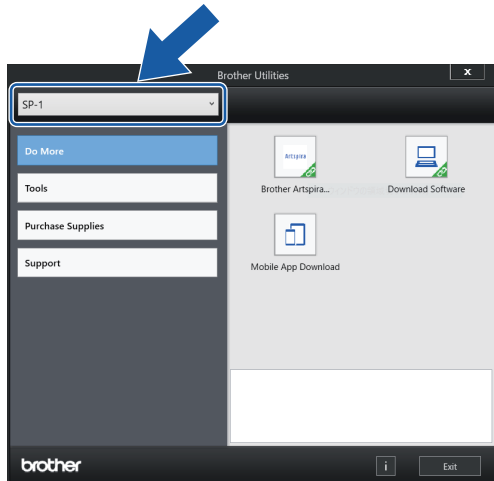



3. Select the operation you want to use.

Related Information

- [Introduction to Your Machine](#)
 - [Uninstall the Brother Software and Drivers \(Windows\)](#)
-

Uninstall the Brother Software and Drivers (Windows)

1. Do one of the following:
 - Windows 11
Click  > **All apps** > **Brother** > **Brother Utilities**.
 - Windows 10
Click  > **Brother** > **Brother Utilities**.
2. Click the drop-down list, and then select your model name (if not already selected). Click **Tools** in the left navigation bar, and then click **Uninstall**.
Follow the instructions in the dialog box to uninstall the software and drivers.

Related Information

- [Access Brother Utilities \(Windows\)](#)

USB / Ethernet Port Locations on Your Brother Machine

The USB and Ethernet ports are located inside the machine (Ethernet ports are available only for certain models).

To install the driver and software necessary to use your machine, go to your model's **Downloads** page at <https://s.brother.ca2ab/>.

1. Place both hands under the plastic tabs on both sides of the machine to lift the top cover (1) into the open position.

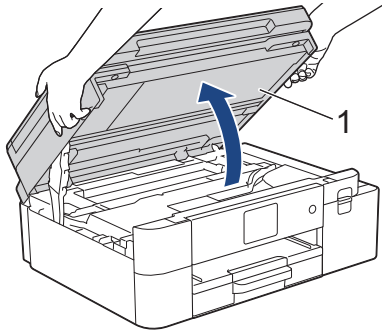

2. Locate the correct port (based on the cable you are using) inside the machine as shown.

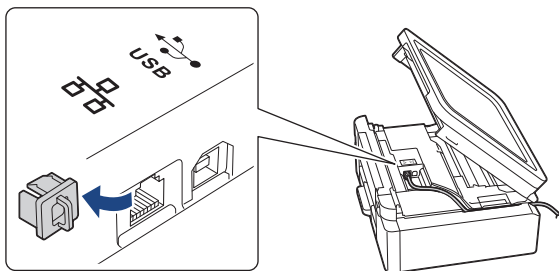

 Carefully guide the cable through the cable channel and out the back of the machine.

3. Gently close the top cover using both hands.

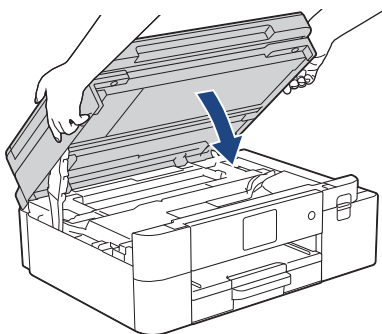

Related Information

- [Introduction to Your Machine](#)

Paper Handling

- [Load Paper](#)

Load Paper

- [Load Paper in the Paper Tray](#)
- [Load Paper in the Manual Feed Slot](#)
- [Unprintable Area](#)
- [Paper Settings](#)
- [Acceptable Print Media](#)
- [Error and Maintenance Messages](#)
- [Paper Handling and Printing Problems](#)

Load Paper in the Paper Tray

- Load Letter or A4 Size Sublimation Paper in the Paper Tray
- Load Legal Size Sublimation Paper in the Paper Tray

Load Letter or A4 Size Sublimation Paper in the Paper Tray

- If the [Check Paper] setting is set to [On] and you pull the paper tray out of the machine, a message appears on the LCD, allowing you to change the paper size.
- Load only one size and type of paper in the paper tray at a time.
- When you load a different paper size in the tray, you must change the Paper Size setting in the machine or the paper size setting on your computer.

1. If the paper support flap (1) is open, close it, and then close the paper support (2).

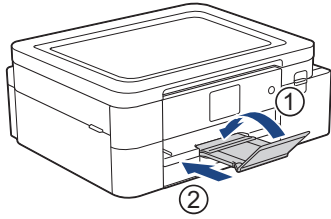

2. Pull the paper tray completely out of the machine.

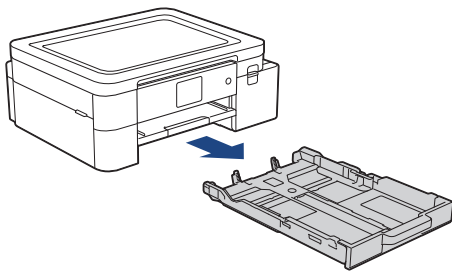

3. Gently press and slide the paper width guides (1) and then the paper length guide (2) to fit the paper size.

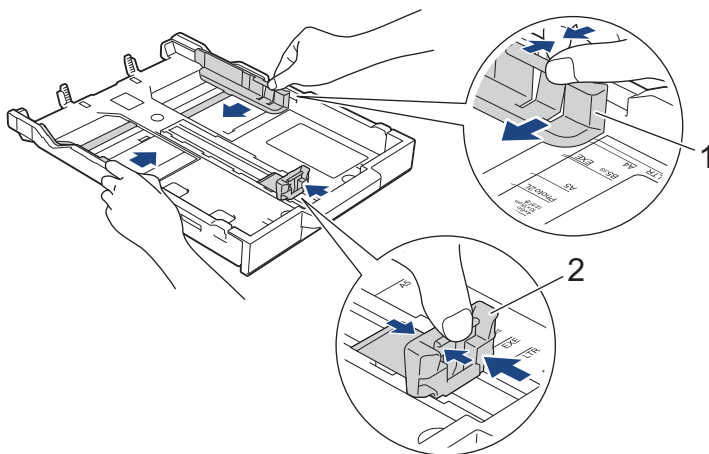

4. Fan the stack of paper well to avoid paper jams and misfeeds.

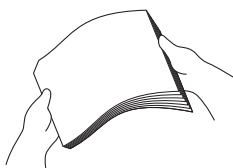

Always make sure the paper is not curled or wrinkled.

-
5. Gently load paper in the paper tray with the printing surface **face down**.

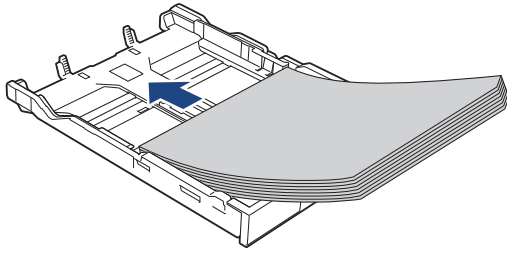

Make sure the paper is flat in the tray and the paper length guide (1) touches the edges of the paper.

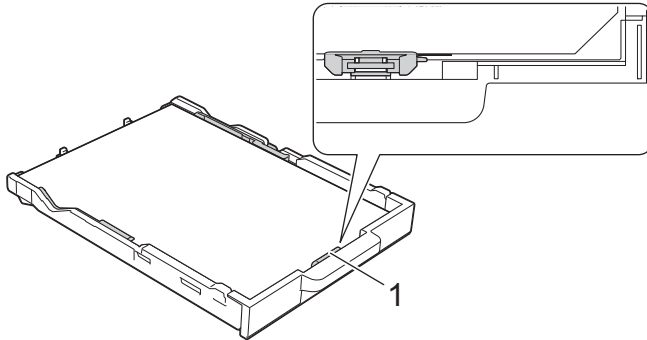

IMPORTANT

- Be careful not to push the paper in too far; it may lift at the back of the tray and cause paper feed problems.



- To add paper before the tray is empty, remove the paper from the tray and combine it with the paper you are adding. Always fan the stack of paper well to prevent the machine from feeding multiple pages.
- When using Brother Sublimation Paper, make sure that the corner with a cut is positioned at the lower right side of the tray (portrait orientation), as shown in the illustration.

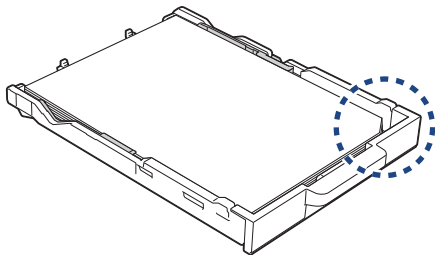

-
6. Gently adjust the paper width guides (1) to fit the paper.
Make sure the paper width guides touch the edges of the paper.

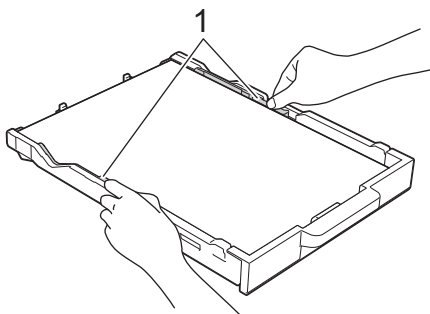

7. Slowly push the paper tray completely into the machine.

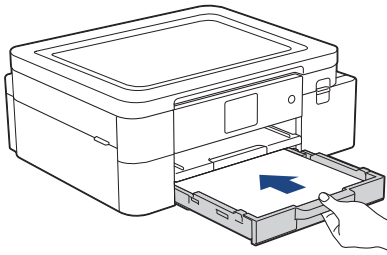

8. Pull out the paper support (1) until it locks into place, and then unfold the paper support flap (2).

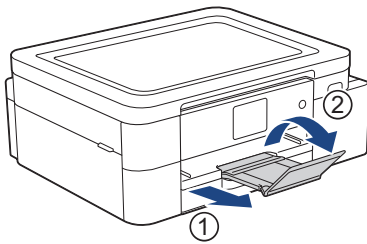

Related Information

- [Load Paper in the Paper Tray](#)

Related Topics:

- [Handle and Use Print Media](#)
 - [Change the Check Paper Setting](#)
 - [Choose the Right Print Media](#)
 - [Change the Paper Size](#)
-

Load Legal Size Sublimation Paper in the Paper Tray

- If the [Check Paper] setting is set to [On] and you pull the paper tray out of the machine, a message appears on the LCD, allowing you to change the paper size.
- Load only one size and type of paper in the paper tray at a time.
- When you load a different paper size in the tray, you must change the Paper Size setting in the machine or the paper size setting on your computer.

1. If the paper support flap (1) is open, close it, and then close the paper support (2).

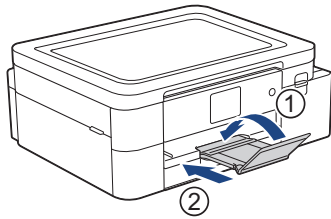

2. Pull the paper tray completely out of the machine.

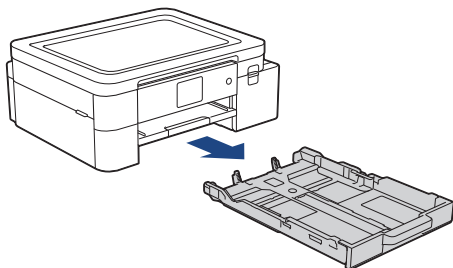

3. Press the square paper tray expansion button (1) and slide out the paper tray until the square paper tray expansion button locks into the square LGL hole.

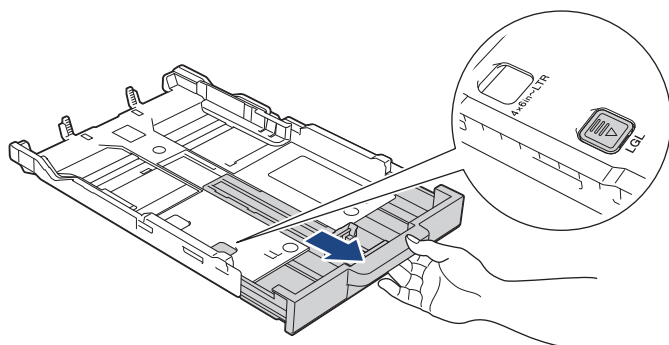
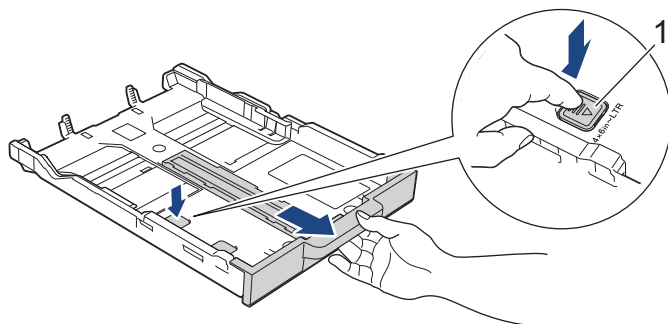

4. Gently press and slide the paper width guides (1) and the paper length guide (2) to fit the paper size.

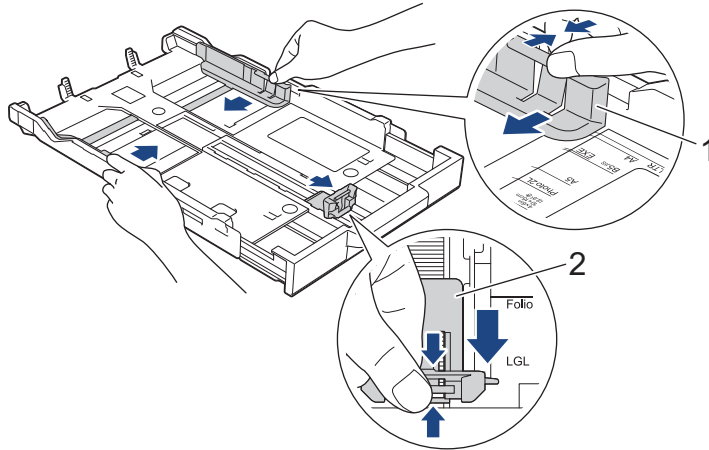

5. Fan the stack of paper well to avoid paper jams and misfeeds.

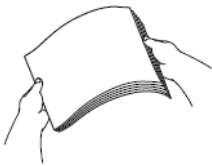

 Always make sure the paper is not curled or wrinkled.

6. Gently load paper in the paper tray with the printing surface **face down**.

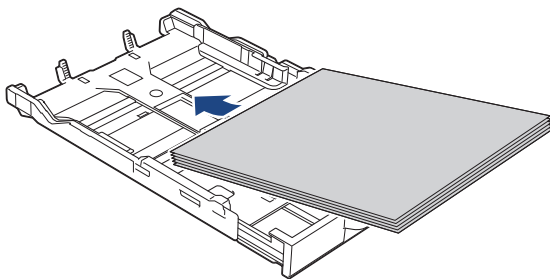

Make sure the paper is flat in the tray and the paper length guide (1) touches the edges of the paper.

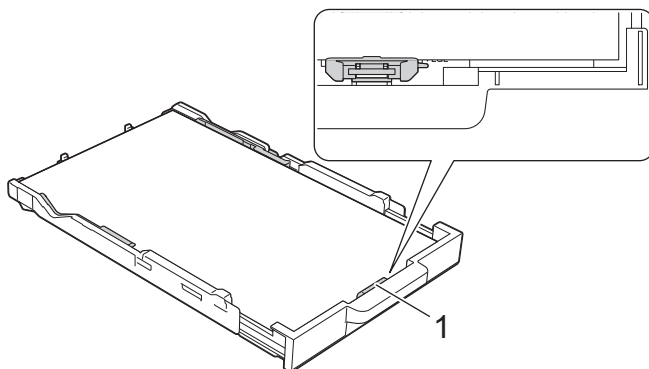

IMPORTANT

Be careful not to push the paper in too far; it may lift at the back of the tray and cause paper feed problems.

 To add paper before the tray is empty, remove the paper from the tray and combine it with the paper you are adding. Always fan the stack of paper well to prevent the machine from feeding multiple pages.

7. Gently adjust the paper width guides (1) to fit the paper.
Make sure the paper guides touch the edges of the paper.

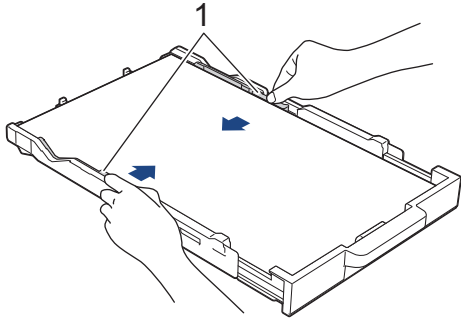

8. Slowly push the paper tray completely into the machine.

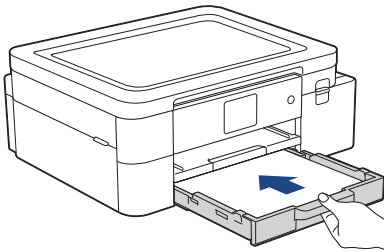

9. Pull out the paper support (1) until it locks into place, and then unfold the paper support flap (2).

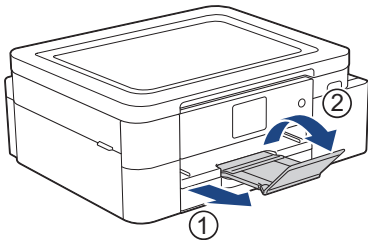

Related Information

- [Load Paper in the Paper Tray](#)

Load Paper in the Manual Feed Slot

Load special print media in this slot, **one sheet of paper** at a time.

 The machine automatically turns on Manual Feed mode when you put paper in the manual feed slot.

1. Open the manual feed slot cover.

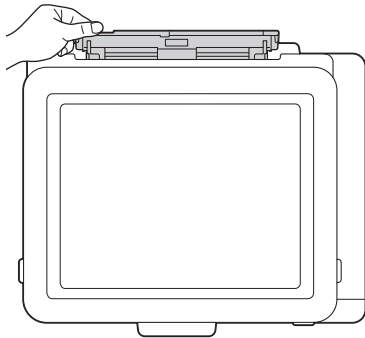
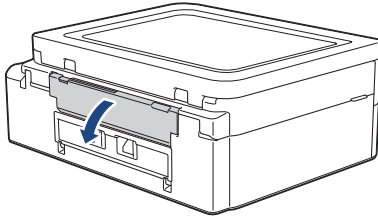

2. Lift the paper support.

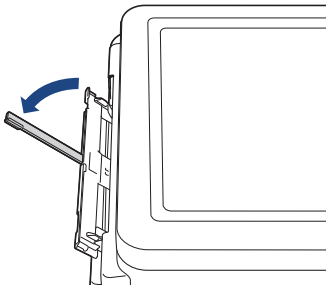

3. Slide the manual feed slot paper guides to fit the width of the paper you are using.

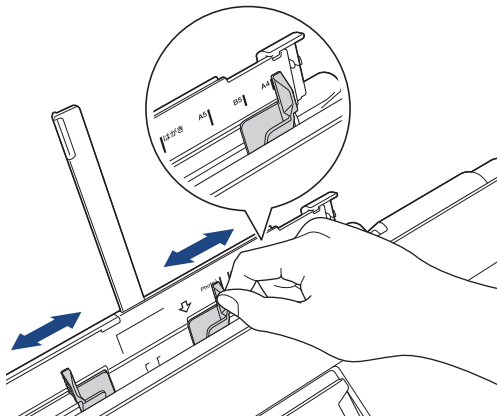

-
4. Load only **one sheet of paper** in the manual feed slot with the printing surface **face up**.
Using both hands, adjust the manual feed slot paper guides to make sure there is no gap between them and the paper.

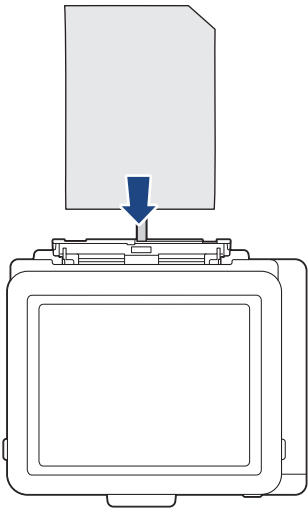
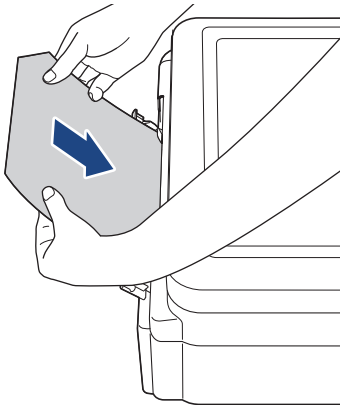

IMPORTANT

- DO NOT load more than **one sheet of paper** in the manual feed slot at any time. Doing this may cause a paper jam. When printing multiple pages, do not feed the next sheet of paper until the LCD displays a message instructing you to feed the next sheet.
- DO NOT load paper in the manual feed slot when you are printing from the paper tray. Doing this may cause a paper jam.

 When using Brother Sublimation Paper, make sure that the corner with a cut is positioned at the upper right side (portrait orientation), as shown in the illustration.

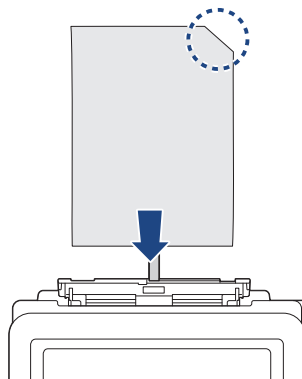

-
5. Using both hands, push **one sheet of paper** into the manual feed slot until the front edge touches the paper feed rollers. Release the paper when you feel the machine pull it. The LCD displays [Manual Feed Slot ready]. Follow the instructions displayed on the LCD.

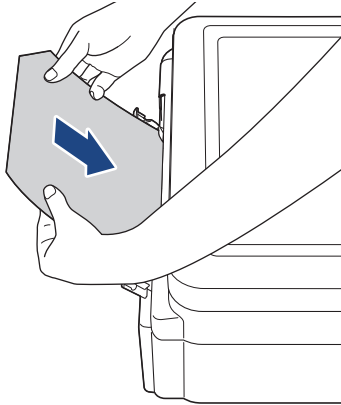

6. Pull out the paper support (1) until it locks into place, and then unfold the paper support flap (2).

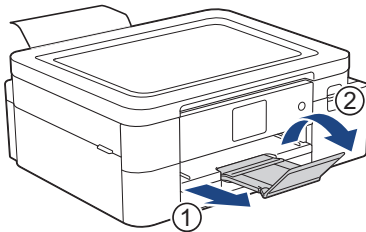

- If the document does not fit on one sheet, the machine will prompt you to load another sheet of paper. Place another sheet of paper in the manual feed slot, and follow the instructions displayed on the LCD.
- Make sure printing has finished before you close the manual feed slot cover.
- When paper is placed in the manual feed slot, the machine always prints from the manual feed slot.
- The machine will eject any paper loaded in the manual feed slot while a test page, report, etc. is being printed.
- The machine will eject paper loaded in the manual feed slot during the machine's cleaning process. Wait until the machine finishes its cleaning, and then load paper in the manual feed slot.



Related Information

- [Load Paper](#)

Related Topics:

- [Handle and Use Print Media](#)
 - [Choose the Right Print Media](#)
 - [Error and Maintenance Messages](#)
-

Unprintable Area

The unprintable area depends on the settings in the application you are using. The figures below show the unprintable areas on Sublimation Paper.

Sublimation Paper

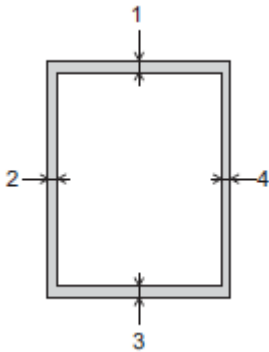

| | Top (1) | Left (2) | Bottom (3) | Right (4) |
|-------------------------------|-----------------|-----------------|-----------------|-----------------|
| Sublimation Paper (all sizes) | 0.12 in. (3 mm) | 0.12 in. (3 mm) | 0.12 in. (3 mm) | 0.12 in. (3 mm) |

✓ Related Information

- [Load Paper](#)

Related Topics:



- [Paper Handling and Printing Problems](#)
-

Paper Settings

- [Change the Paper Size](#)
- [Change the Check Paper Setting](#)

Change the Paper Size

Set the Paper Size settings for the paper tray.

- When you change the size of the paper you load in the tray, you must change the Paper Size setting on the LCD at the same time.
1. Press  [Settings] > [All Settings] > [General Setup].
 2. Press [Paper Size].
 3. Press the option you want.
 4. Press .



The machine ejects paper with the printed surface face up onto the paper tray at the front of the machine.



Related Information

- [Paper Settings](#)



Related Topics:

- [Load Letter or A4 Size Sublimation Paper in the Paper Tray](#)
 - [Acceptable Print Media](#)
 - [Error and Maintenance Messages](#)
 - [Paper Handling and Printing Problems](#)
-

Change the Check Paper Setting

If this setting is set to [On] and the paper tray is removed, the LCD displays a message asking if you want to change the Paper Size settings.

The default setting is [On].

1. Press  [Settings] > [All Settings] > [General Setup].
2. Press ▲ or ▼ to display the [Check Paper] option, and then press it.
3. Press [On] or [Off].
4. Press .

Related Information

- [Paper Settings](#)

Related Topics:

- [Load Letter or A4 Size Sublimation Paper in the Paper Tray](#)
 - [Error and Maintenance Messages](#)
-

Acceptable Print Media

Use only Sublimation Paper when printing with this machine. Please note that Sublimation Ink is not suitable for printing on standard office paper.

For best results, use Brother paper.

- Avoid touching the printed surface of the paper immediately after printing; the surface may not be completely dry and may stain your fingers.

| Paper Type | Paper Size | |
|-------------------|--------------|---|
| Sublimation Paper | Letter | 8 1/2 x 11 in. (215.9 x 279.4 mm) |
| | A4 | 8.3 x 11.7 in. (210 x 297 mm) |
| | Legal | 8 1/2 x 14 in. (215.9 x 355.6 mm) |
| | User Defined | 3.5 x 5.0 to 8.5 x 14.0 in. (88.9 x 127.0 to 215.9 x 355.6 mm) |



Related Information

- [Load Paper](#)
 - [Recommended Print Media](#)
 - [Handle and Use Print Media](#)
 - [Choose the Right Print Media](#)

Related Topics:

- [Change the Paper Size](#)
 - [Paper Handling and Printing Problems](#)
-

Recommended Print Media

For the best print quality, we recommend using the Brother paper listed in the table.
Brother paper may not be available in all countries.

Brother paper

| Paper Type | Item |
|----------------------------|-------|
| Sublimation Paper (Letter) | SP01L |



Related Information

- [Acceptable Print Media](#)
-

Handle and Use Print Media

- Store paper in its original packaging and keep it sealed. Keep the paper flat and away from moisture, direct sunlight and heat.
- Avoid touching the printable side.

IMPORTANT

DO NOT use the following types of paper:

- Damaged, curled, wrinkled, or irregularly shaped

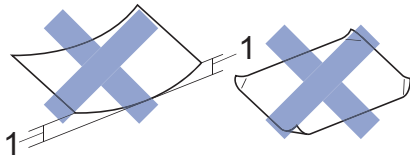

1. 0.08 in. (2 mm) or greater curl may cause jams to occur.

- Extremely shiny or highly textured
- Paper that cannot be arranged uniformly when stacked
- Paper made with a short grain



Avoid using curled Sublimation Paper, as it could cause paper jams, smudged ink, or misaligned images. Flatten curled paper as much as possible without touching the printable side.

Brother Sublimation Paper

- To be sure you are using the printable side, the corner with a cut should be positioned at the lower right side of the tray (portrait orientation).
- The cut corner is a guideline for loading the paper correctly. Do not print on the reverse side.
- Make sure your image is positioned away from the cut corner area.

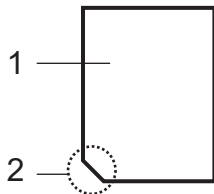

1. Printable side
2. Cut corner



Related Information

- [Acceptable Print Media](#)
- [Unprintable Area](#)

Related Topics:

- [Load Paper in the Paper Tray](#)

Choose the Right Print Media

- Paper Tray Capacity
- Load Letter or A4 Size Sublimation Paper in the Paper Tray
- Load Paper in the Manual Feed Slot

Paper Tray Capacity

| | Paper Size | Paper Types | No. of sheets | Weight | Thickness |
|------------------|-------------------|-------------------|------------------|---|-------------------------------|
| Paper Tray | Letter, A4, Legal | Sublimation Paper | 100 ¹ | 17 to 32 lb (64 to 120 g/m ²) | 3 to 6 mil (0.08 to 0.15 mm) |
| Manual Feed Slot | Letter, A4, Legal | Sublimation Paper | 1 | 17 to 79 lb (64 to 300 g/m ²) | 3 to 12 mil (0.08 to 0.30 mm) |

¹ When using Brother Sublimation Paper (SP01L)



Related Information

- [Choose the Right Print Media](#)
-

Print

Depending on the output you want to create and the images you use, you may need to print a mirror, or horizontally-reversed, image.

The default settings for mirror printing differ depending on the application you print from. Check the settings before printing. If your application does not have mirror print settings, you must manually create an horizontally-reversed image before printing.



Related Information

- [Print from Your Computer \(Windows\)](#)
 - [Print from Your Computer \(Mac\)](#)
 - [Print from Your Mobile Device](#)
-

Print from Your Computer (Windows)

- [Print a Document \(Windows\)](#)
- [Cancel a Print Job \(Windows\)](#)
- [Print a Color Document in Grayscale \(Windows\)](#)
- [Prevent Smudged Printouts and Paper Jams \(Windows\)](#)
- [Use a Print Profile \(Windows\)](#)
- [Change the Default Print Settings \(Windows\)](#)
- [Print Settings \(Windows\)](#)

Print a Document (Windows)

1. Select the print command in your application.
2. Select your model's name, and then click the printing properties or preferences button.
The printer driver window appears.
3. Make sure you have loaded the correct size paper in the paper tray.
4. Click the **Basic** tab.
5. Click the **Paper Size** drop-down list, and then select your paper size.
6. For **Color / Grayscale**, select the **Color** or **Grayscale** option.
7. In the **Orientation** field, select the **Portrait** or **Landscape** option to set the orientation of your printout.



If your application contains a similar setting, we recommend that you set the orientation using the application.

8. Type the number of copies (1-999) you want in the **Copies** field.
9. To print multiple pages on a single sheet of paper or print one page of your document on multiple sheets, click the **Multiple Page** drop-down list, and then select your options.
10. Change other printer settings, if needed.
11. Click **OK**.
12. Complete your print operation.



Related Information

- [Print from Your Computer \(Windows\)](#)

Related Topics:

- [Check the Ink Volume](#)
 - [Print Settings \(Windows\)](#)
-

Cancel a Print Job (Windows)

If a print job was sent to the print queue and did not print, or was sent to the print queue in error, you may have to delete it to allow subsequent jobs to print.

1. Double-click the printer icon  in the task tray.
2. Select the print job you want to cancel.
3. Click the **Document** menu.
4. Select **Cancel**.
5. Click **Yes**.



Related Information

- [Print from Your Computer \(Windows\)](#)

Related Topics:

- [Monitor Machine Status from Your Computer \(Windows\)](#)
-

Print a Color Document in Grayscale (Windows)

Grayscale mode makes the print processing speed faster than color mode. If your document contains color, selecting Grayscale mode prints your document in 256 levels of grayscale.

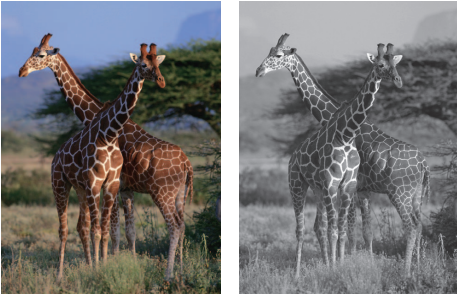

1. Select the print command in your application.
2. Select your model's name, and then click the printing properties or preferences button.
The printer driver window appears.
3. Click the **Basic** tab.
4. For **Color / Grayscale**, select **Grayscale**.
5. Change other printer settings, if needed.
6. Click **OK**.
7. Complete your print operation.



Related Information

- [Print from Your Computer \(Windows\)](#)

Prevent Smudged Printouts and Paper Jams (Windows)

Some types of print media may need more drying time. Change the **Reduce Smudge** option if you have problems with smudged printouts or paper jams.

1. Select the print command in your application.
2. Select your model's name, and then click the printing properties or preferences button.
The printer driver window appears.
3. Click the **Advanced** tab.
4. Click the **Other Print Options** button.
5. Select the **Reduce Smudge** option on the left side of the screen.
6. Select one of the following options:

| Media Type | Option | Description |
|-------------------|-----------------|---|
| Sublimation Paper | Off / On | Select Off to print at normal speed. Select On to print at a slower speed. |

7. Click **OK** to return to the printer driver window.
8. Click **OK**.
9. Complete your print operation.

Related Information

- [Print from Your Computer \(Windows\)](#)

Related Topics:

- [Paper Handling and Printing Problems](#)
 - [Change the Print Options to Improve Your Print Results](#)
-

Use a Print Profile (Windows)

Print Profiles are presets designed to give you quick access to frequently-used printing configurations.

1. Select the print command in your application.
2. Select your model's name, and then click the printing properties or preferences button.
The printer driver window appears.
3. Click the **Print Profiles** tab.

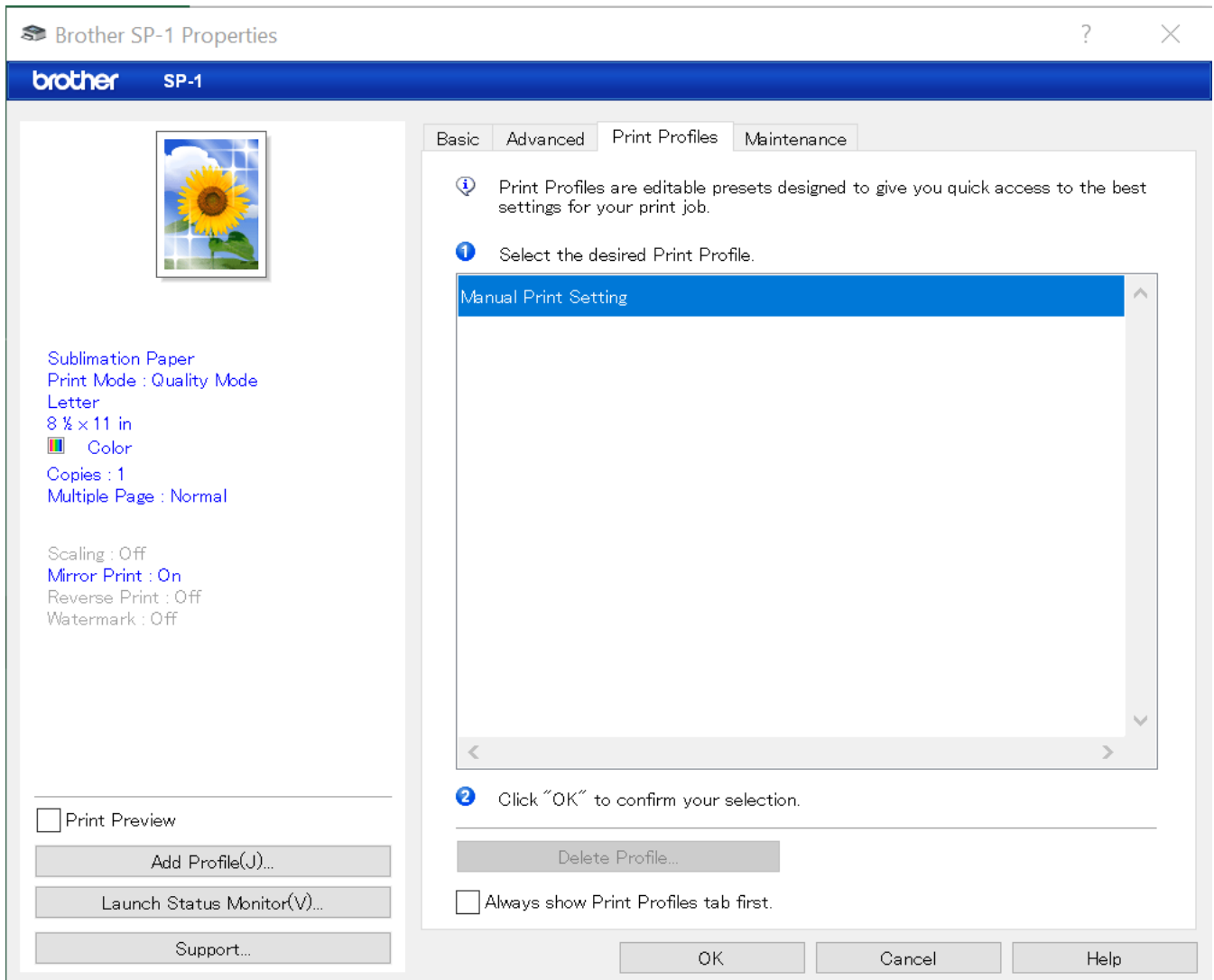

4. Select your profile from the print profile list.
The profile settings are shown on the left side of the printer driver window.
5. Do one of the following:
 - If the settings are correct for your print job, click **OK**.
 - To change the settings, go back to the **Basic** or **Advanced** tab, change settings, and then click **OK**.



To display the **Print Profiles** tab at the front of the window the next time you print, select the **Always show Print Profiles tab first.** checkbox.



Related Information

- [Print from Your Computer \(Windows\)](#)
 - [Create or Delete Your Print Profile \(Windows\)](#)

Related Topics:

- [Print Settings \(Windows\)](#)
-

Create or Delete Your Print Profile (Windows)

Add up to 20 new print profiles with customized settings.

1. Select the print command in your application.
2. Select your model's name, and then click the printing properties or preferences button.
The printer driver window appears.
3. Do one of the following:

To create a new print profile:

- a. Click the **Basic** tab and the **Advanced** tab, and configure the print settings you want for the new Print Profile.
- b. Click the **Print Profiles** tab.
- c. Click **Add Profile**.
The **Add Profile** dialog box appears.
- d. Type the new profile name in the **Name** field.
- e. Click the icon you want to use to represent this profile from the icon list.
- f. Click **OK**.

The new Print Profile name is added to the list in the **Print Profiles** tab.

To delete a print profile that you created:

- a. Click the **Print Profiles** tab.
- b. Click **Delete Profile**.
The **Delete Profile** dialog box appears.
- c. Select the profile you want to delete.
- d. Click **Delete**.
- e. Click **Yes**.
- f. Click **Close**.



Related Information

- [Use a Print Profile \(Windows\)](#)

Change the Default Print Settings (Windows)

When you change an application's print settings, the changes only apply to documents printed with that application. To change print settings for all Windows applications, you must configure the printer driver properties.

1. Do one of the following:

- Windows 11

Click  > **All apps** > **Windows Tools** > **Control Panel**. In the **Hardware and Sound** group, click **View devices and printers**.

- For Windows 10

Click  > **Windows System** > **Control Panel**. In the **Hardware and Sound** group, click **View devices and printers**.

2. Right-click your model's icon, and then select **Printer properties**. If printer driver options appear, select your printer driver.

The printer properties dialog box appears.

3. Click the **General** tab, and then click the **Printing Preferences...** or **Preferences...** button.

The printer driver dialog box appears.

4. Select the print settings you want to use as defaults for all of your Windows programs.

5. Click **OK**.

6. Close the printer properties dialog box.



Related Information

- [Print from Your Computer \(Windows\)](#)

Related Topics:

- [Print Settings \(Windows\)](#)
-

Print Settings (Windows)

>> [Basic Tab](#)

>> [Advanced Tab](#)

Basic Tab

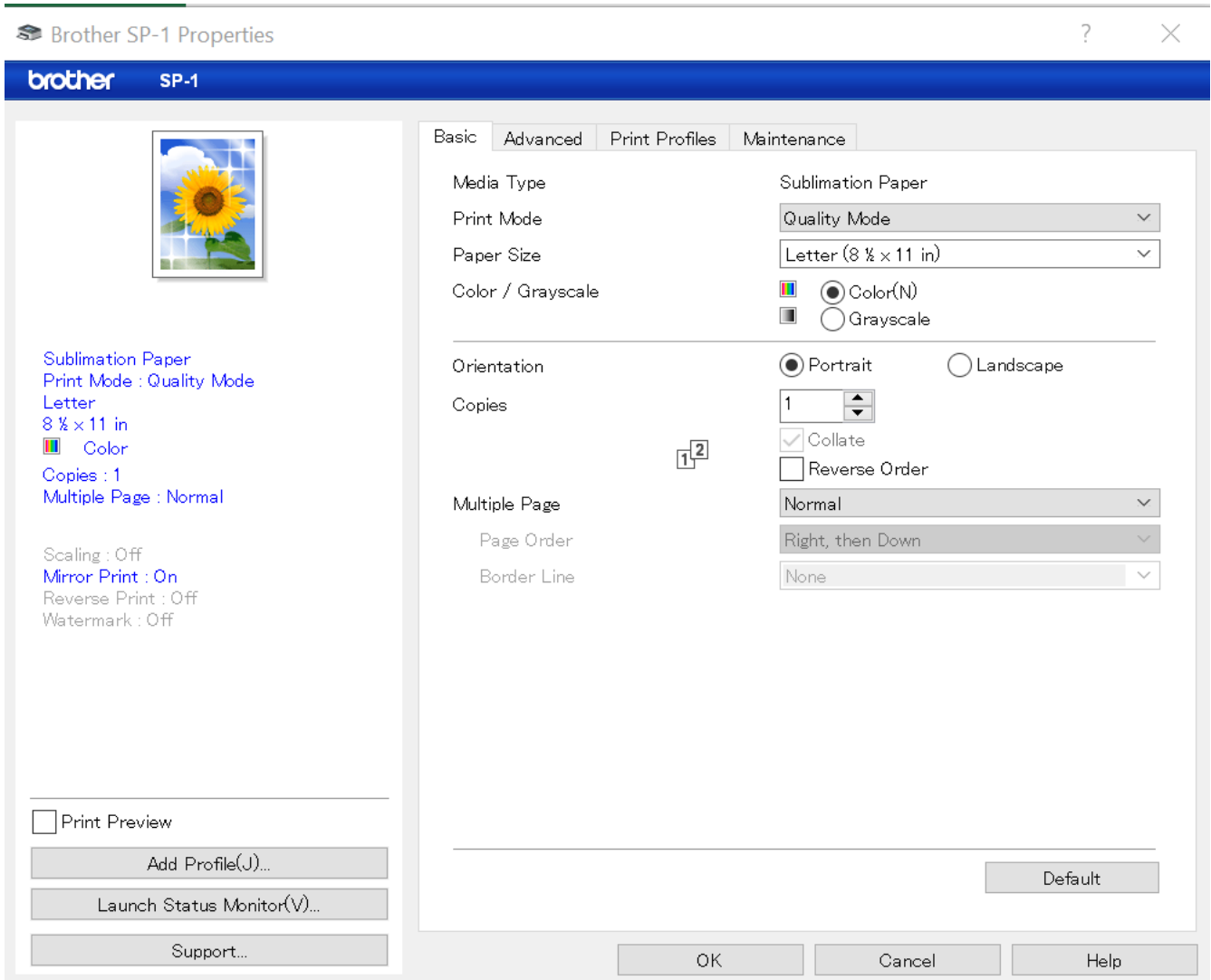

1. Media Type

To achieve the best print results, the machine automatically adjusts its print settings according to the media type.

2. Print Mode

Select the print quality you want. Because print quality and speed are related, **Quality Mode** will take longer to print than **Speed Mode**.

3. Paper Size

Select the paper size you want to use. You can either choose from standard paper sizes or create a custom paper size.

4. Color / Grayscale

Select color or grayscale printing. The print speed is faster in grayscale mode than it is in color mode. If your document contains color and you select grayscale mode, your document will be printed using 256 levels of grayscale.

5. Orientation

Select the orientation (portrait or landscape) of your printout.

If your application contains a similar setting, we recommend that you set the orientation using the application.

6. Copies

Type the number of copies (1-999) that you want to print in this field.

Collate

Select this option to print sets of multi-page documents in the original page order. When this option is selected, one complete copy of your document will print, and then reprint according to the number of copies you choose. If this option is not selected, then each page will print according to the number of copies chosen before the next page of the document is printed.

Reverse Order

Select this option to print your document in reverse order. The last page of your document will be printed first.

7. Multiple Page

Select this option to print multiple pages on a single sheet of paper, or print one page of your document on multiple sheets.

Page Order

Select the page order when printing multiple pages on a single sheet of paper.

Border Line

Select the type of border to use when printing multiple pages on a single sheet of paper.

Advanced Tab

Brother SP-1 Properties

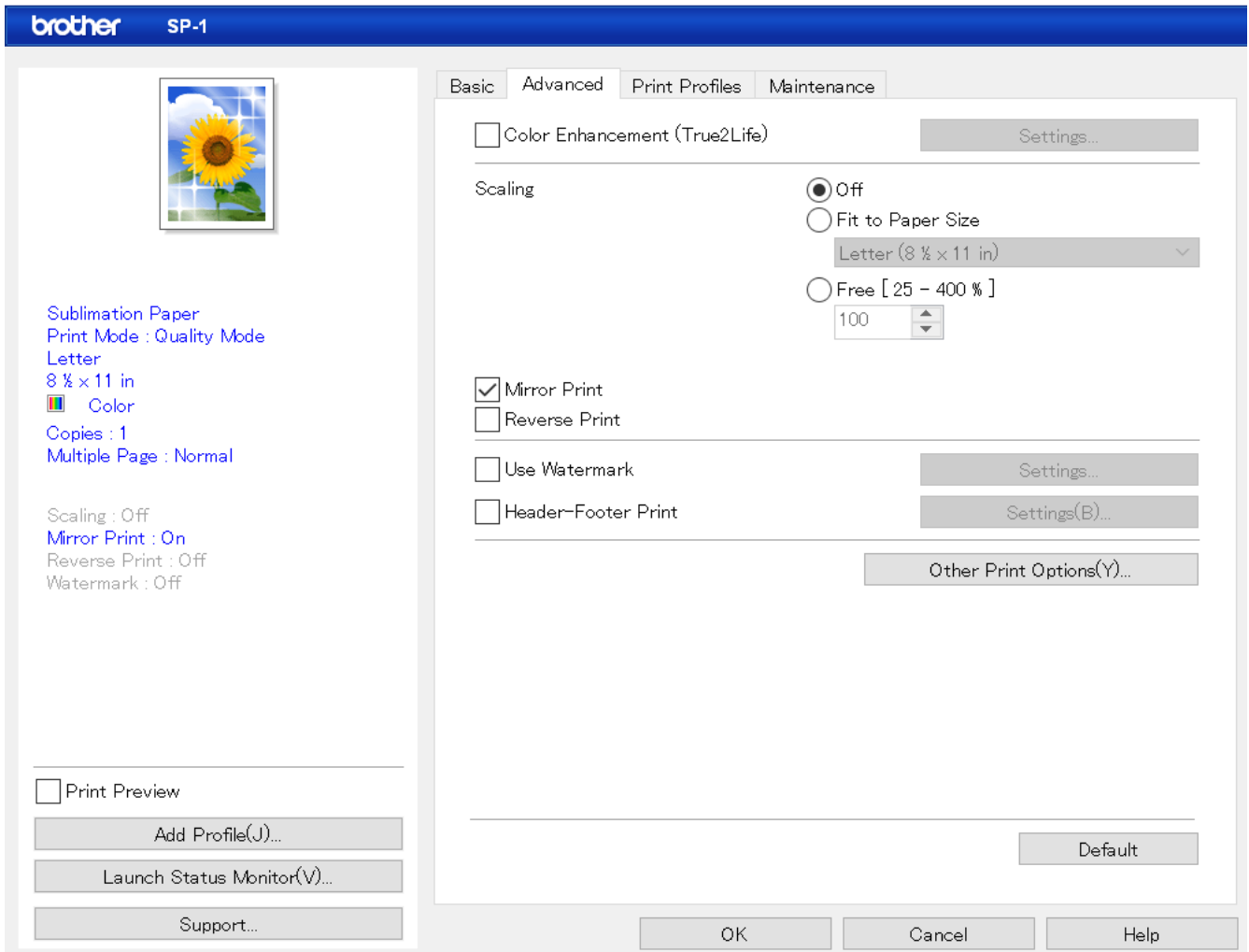

1. Color Enhancement (True2Life)

Select this option to use the Color Enhancement feature. This feature analyzes your image to improve its sharpness, white balance and color density. This process may take several minutes depending on the image size and your computer's specifications.

2. Scaling

Select these options to enlarge or reduce the size of the pages in your document.

Fit to Paper Size

Select this option to enlarge or reduce the document pages to fit a specified paper size. When you select this option, select the paper size you want from the drop-down list.

Free [25 - 400 %]

Select this option to enlarge or reduce the document pages manually. When you select this option, type a value into the field.

3. Mirror Print

Select this option to reverse the printed image on the page horizontally from left to right.

4. Reverse Print

Select this option to rotate the printed image 180 degrees.

5. Use Watermark

Select this option to print a logo or text on your document as a watermark. Select one of the preset watermarks, add a new watermark, or use an image file you have created.

6. Header-Footer Print

Select this option to print the date, time and PC login user name on the document.

7. Other Print Options button

Advanced Color Settings

Select the method that the machine uses to arrange dots to express halftones.

The printout color can be adjusted to achieve the closest match to what appears on your computer screen.

Reduce Smudge

Some types of print media may need more drying time. Change this option if you have problems with smudged printouts or paper jams.

Retrieve Printer's Color Data

Select this option to optimize the print quality using the machine's factory settings, which are set specifically for your Brother machine. Use this option when you have replaced the machine or changed the machine's network address.



Related Information

- [Print from Your Computer \(Windows\)](#)

Related Topics:

- [Error and Maintenance Messages](#)
 - [Paper Handling and Printing Problems](#)
 - [Print a Document \(Windows\)](#)
 - [Use a Print Profile \(Windows\)](#)
 - [Change the Default Print Settings \(Windows\)](#)
 - [Change the Print Options to Improve Your Print Results](#)
-

Print from Your Computer (Mac)

- [Print Using AirPrint](#)

Print from Your Mobile Device

- [Brother Artspira](#)

Network

- [Supported Basic Network Features](#)
- [Configure Network Settings](#)
- [Wireless Network Settings](#)
- [Network Features](#)

Supported Basic Network Features

The print server supports various features depending on the operating system. Use this table to see which network features and connections are supported by each operating system.

| Operating Systems | Windows | macOS |
|-----------------------------------|---------|-------|
| Printing | Yes | Yes |
| Web Based Management ¹ | Yes | Yes |
| Status Monitor | Yes | No |

¹ The default password to manage this machine's settings is located on the back of the machine and marked "**Pwd**". We recommend immediately changing the default password to protect your machine from unauthorized access.



When connecting your machine to an outside network such as the Internet, make sure your network environment is protected by a separate firewall or other means in order to prevent information leaks due to inadequate settings or unauthorized access by malicious third parties.



Related Information

- [Network](#)

Related Topics:

- [Set or Change a Login Password for Web Based Management](#)
-

Configure Network Settings

- [Configure Network Settings Using the Control Panel](#)
- [Change Machine Settings Using Web Based Management](#)

Configure Network Settings Using the Control Panel

To configure the machine for your network, use the control panel's [Network] menu selections.



- For information about the network settings you can configure using the control panel, see *Related Information: Settings Tables (2.7" Touchscreen models)*.
- You can also use management utilities, such as Web Based Management, to configure and change your Brother machine's network settings.

1. Press  [Settings] > [Network].
2. Press ▲ or ▼ to display the network option, and then press it. Repeat this step until you access the menu you want to configure, and then follow the touchscreen LCD instructions.



Related Information

- [Configure Network Settings](#)

Related Topics:

- [Settings Tables \(2.7" Touchscreen models\)](#)
-

Wireless Network Settings

- [Use the Wireless Network](#)
- [Use Wi-Fi Direct®](#)
- [Enable/Disable Wireless LAN](#)
- [Print the WLAN Report](#)

Use the Wireless Network

- [Before Configuring Your Machine for a Wireless Network](#)
- [Configure Your Machine for a Wireless Network Using the Setup Wizard from Your Computer](#)
- [Configure Your Machine for a Wireless Network Using the Machine's Control Panel Setup Wizard](#)
- [Configure Your Machine for a Wireless Network Using the One Push Method of Wi-Fi Protected Setup™ \(WPS\)](#)
- [Configure Your Machine for a Wireless Network Using the PIN Method of Wi-Fi Protected Setup™ \(WPS\)](#)
- [Configure Your Machine for a Wireless Network When the SSID is Not Broadcast](#)
- [Configure Your Machine for an Enterprise Wireless Network](#)

Before Configuring Your Machine for a Wireless Network

Before attempting to configure a wireless network, confirm the following:

- If you are using an enterprise wireless network, you must know the User ID and Password.
- To achieve optimum results with normal everyday document printing, place your machine as close to the wireless LAN access point/router as possible with minimal obstructions. Large objects and walls between the two devices and interference from other electronic devices can affect the data transfer speed of your documents.
Due to these factors, wireless may not be the best method of connection for all types of documents and applications. If you are printing large files, such as multi-page documents with mixed text and large graphics, you may want to consider selecting wired Ethernet for faster data transfer (supported models only), or USB for the fastest throughput speed.
- Although your machine can be used in both a wired and wireless network (supported models only), only one connection method can be used at a time. However, a wireless network connection and Wi-Fi Direct connection, or a wired network connection (supported models only) and Wi-Fi Direct connection can be used at the same time.
- If there is a signal in the vicinity, wireless LAN allows you to freely make a LAN connection. However, if security settings are not correctly configured, the signal may be intercepted by malicious third-parties, possibly resulting in:
 - Theft of personal or confidential information
 - Improper transmission of information to parties impersonating the specified individuals
 - Dissemination of transcribed communication contents that were intercepted



Make sure you know your wireless router/access point's Network Name (SSID) and Network Key (Password). If you cannot find this information, consult the manufacturer of your wireless router/access point, your system administrator, or Internet provider. Brother cannot provide this information.



Related Information

- [Use the Wireless Network](#)
-

Configure Your Machine for a Wireless Network Using the Setup Wizard from Your Computer

1. Do one of the following:
 - Windows
Download the installer from your model's **Downloads** page at <https://s.brother/ca2ab/>.
 - Mac
 - a. Download the installer from your model's **Downloads** page at <https://s.brother/ca2ab/>.
 - b. Start the installer, and then double-click the **Start Here Mac** icon.
2. Follow the on-screen instructions.
3. Select **Wireless Network Connection (Wi-Fi)**, and then click **Next**.
4. Follow the on-screen instructions.

You have completed the wireless network setup.



Related Information

- [Use the Wireless Network](#)
-

Configure Your Machine for a Wireless Network Using the Machine's Control Panel Setup Wizard

Before configuring your machine, we recommend writing down your wireless network settings. You will need this information before you continue with the configuration.

1. Check and record the current wireless network settings of the computer to which you are connecting.

| Network Name (SSID) |
|---------------------|
| |

| Network Key (Password) |
|------------------------|
| |

For example:

| Network Name (SSID) |
|---------------------|
| HELLO |

| Network Key (Password) |
|------------------------|
| 12345 |



- Your access point/router may support the use of multiple WEP keys, but your Brother machine supports the use of only the first WEP key.
- If you need assistance during setup and want to contact Brother Customer Service, make sure you have your SSID (Network Name) and Network Key ready. We cannot assist you in locating this information.
- If you do not know this information (SSID and Network Key), you cannot continue the wireless setup.

How can I find this information?

- Check the documentation provided with your wireless access point/router.
- The initial SSID could be the manufacturer's name or the model name.
- If you do not know the security information, please consult the router manufacturer, your system administrator, or your Internet provider.

2. Press  [Settings] > [Network] > [WLAN (Wi-Fi)] > [Find Wi-Fi Network].
3. When [Enable WLAN?] appears, press [Yes].
The wireless setup wizard starts. To cancel, press [No].
4. The machine searches for your network and display a list of available SSIDs. When a list of SSIDs appears, press ▲ or ▼ to select the SSID you want. Press [OK].
5. Do one of the following:
 - If you are using an authentication and encryption method that requires a Network Key, enter the Network Key you wrote down in the first step.
Enter the key, and then press [OK] to apply your settings.
 - If your authentication method is Open System and your encryption mode is None, go to the next step.
6. The machine attempts to connect to the wireless device you have selected.

If your wireless device is connected successfully, the LCD displays [Connected].

You have completed the wireless network setup. To install the drivers and software necessary to use your machine, go to your model's **Downloads** page at <https://s.brother/ca2ab/>.



Related Information

- [Use the Wireless Network](#)
-

Configure Your Machine for a Wireless Network Using the One Push Method of Wi-Fi Protected Setup™ (WPS)

If your wireless access point/router supports WPS (Push Button Configuration), you can use WPS from your machine's control panel menu to configure your wireless network settings.

1. Press  [Settings] > [Network] > [WLAN (Wi-Fi)] > [WPS/Push Button].
2. When [Enable WLAN?] appears, press [Yes].
The wireless setup wizard starts. To cancel, press [No].
3. When the touchscreen instructs you to start WPS, press the WPS button on your wireless access point/ router.
Then press [OK] on your machine. Your machine automatically tries to connect to your wireless network.

If your wireless device is connected successfully, the LCD displays [Connected].

You have completed the wireless network setup. To install the drivers and software necessary to use your machine, go to your model's **Downloads** page at <https://s.brother/ca2ab/>.



Related Information

- [Use the Wireless Network](#)

Configure Your Machine for a Wireless Network Using the PIN Method of Wi-Fi Protected Setup™ (WPS)

If your wireless LAN access point/router supports WPS, you can use the Personal Identification Number (PIN) Method to configure your wireless network settings.

The PIN Method is one of the connection methods developed by the Wi-Fi Alliance®. By submitting a PIN created by an Enrollee (your machine) to the Registrar (a device that manages the wireless LAN), you can set up the wireless network and security settings. For more information on how to access WPS mode, see the instructions provided with your wireless access point/router.

Type A

Connection when the wireless LAN access point/router (1) doubles as the Registrar.

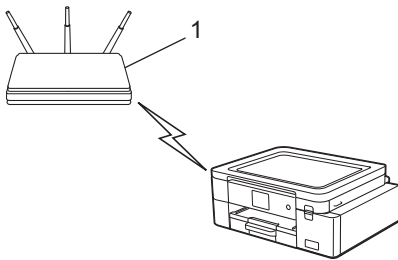

Type B

Connection when another device (2), such as a computer, is used as the Registrar.

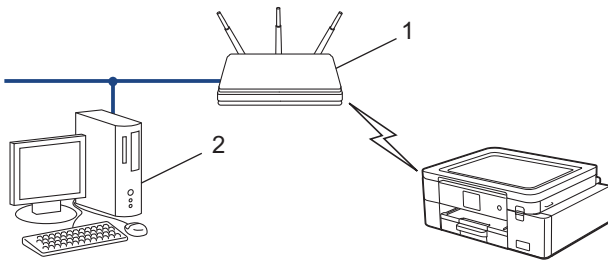



1. Press  [Settings] > [Network] > [WLAN (Wi-Fi)] > [WPS/PIN Code].
2. When [Enable WLAN?] appears, press [Yes].
The wireless setup wizard starts. To cancel, press [No].
3. The LCD displays an eight-digit PIN and the machine starts searching for a wireless LAN access point/router.
4. Using a computer connected to the network, in your browser's address bar, type the IP address of the device you are using as the Registrar. (For example: <http://192.168.1.2>)
5. Go to the WPS settings page and type the PIN, and then follow the on-screen instructions.



- The Registrar is usually the wireless LAN access point/router.
- The settings page may differ depending on the brand of wireless LAN access point/router. For more information, see the instructions supplied with your wireless LAN access point/router.

If you are using a Windows 10, or Windows 11 computer as a Registrar, complete the following steps:

6. Do one of the following:
 - Windows 11
Click  > **All apps** > **Windows Tools** > **Control Panel**. In the **Hardware and Sound** group, click **Add a device**.
 - Windows 10
Click  > **Windows System** > **Control Panel**. In the **Hardware and Sound** group, click **Add a device**.



- To use a Windows 10 or Windows 11 computer as a Registrar, you must register it to your network in advance. For more information, see the instructions supplied with your wireless LAN access point/router.
- If you use a Windows 10 or Windows 11 computer as a Registrar, you can install the printer driver after the wireless configuration by following the on-screen instructions. To install the driver and software necessary to use your machine, go to your model's **Downloads** page at <https://s.brother/ca2ab/>.

7. Select your machine and click **Next**.
8. Type the PIN displayed on the machine's LCD, and then click **Next**.
9. Click **Close**.



Related Information

- [Use the Wireless Network](#)
-

Configure Your Machine for a Wireless Network When the SSID is Not Broadcast

Before configuring your machine, we recommend writing down your wireless network settings. You will need this information before you continue with the configuration.

1. Check and write down the current wireless network settings.

| Network Name (SSID) |
|---------------------|
| |

| Authentication Method | Encryption Mode | Network Key (Password) |
|-----------------------|-----------------|------------------------|
| Open System | NONE | - |
| | WEP | |
| Shared Key | WEP | |
| WPA/WPA2-PSK | AES | |
| | TKIP | |

For example:

| Network Name (SSID) |
|---------------------|
| HELLO |

| Authentication Method | Encryption Mode | Network Key (Password) |
|-----------------------|-----------------|------------------------|
| WPA2-PSK | AES | 12345678 |

 If your router uses WEP encryption, enter the key used as the first WEP key. Your Brother machine supports the use of the first WEP key only.

2. Press  [Settings] > [Network] > [WLAN (Wi-Fi)] > [Find Wi-Fi Network].
3. When [Enable WLAN?] appears, press [Yes].
The wireless setup wizard starts. To cancel, press [No].
4. The machine searches for your network and displays a list of available SSIDs. Press ▲ or ▼ to display the [<New SSID>] option, and then press it.
5. Press [OK].
6. Enter the SSID name, and then press [OK].

 For more information about how to enter text, see *Related Information*.

7. Select the Authentication Method, and then press it.
8. Do one of the following:
 - If you selected the [Open System] option, press either [None] or [WEP].
If you selected the [WEP] option for Encryption type, enter the WEP key, and then press [OK].
 - If you selected the [Shared Key] option, enter the WEP key, and then press [OK].
 - If you selected the [WPA/WPA2-PSK] option, press either [TKIP+AES] or [AES].
Enter the WPA key, and then press [OK].

 For more information about how to enter text, see *Related Information*.

- Your Brother machine supports the use of the first WEP key only.

9. The machine attempts to connect to the wireless device you have selected.

If your wireless device is connected successfully, the LCD displays [Connected].

You have completed the wireless network setup. To install the drivers and software necessary to use your machine, go to your model's **Downloads** page at <https://s.brother/ca2ab/>.



Related Information

- [Use the Wireless Network](#)

Related Topics:

- [If You Are Having Difficulty with Your Machine's Network](#)
 - [Enter Text on Your Brother Machine](#)
-

Configure Your Machine for an Enterprise Wireless Network

Before configuring your machine, we recommend writing down your wireless network settings. You will need this information before you continue with the configuration.

1. Check and record the current wireless network settings.

| Network Name (SSID) |
|---------------------|
| |

| Authentication Method | Encryption Mode | User ID | Password |
|-----------------------|-----------------|---------|----------|
| EAP-FAST/NONE | AES | | |
| | TKIP | | |
| EAP-FAST/MS-CHAPv2 | AES | | |
| | TKIP | | |
| EAP-FAST/GTC | AES | | |
| | TKIP | | |
| PEAP/MS-CHAPv2 | AES | | |
| | TKIP | | |
| PEAP/GTC | AES | | |
| | TKIP | | |
| EAP-TTLS/CHAP | AES | | |
| | TKIP | | |
| EAP-TTLS/MS-CHAP | AES | | |
| | TKIP | | |
| EAP-TTLS/MS-CHAPv2 | AES | | |
| | TKIP | | |
| EAP-TTLS/PAP | AES | | |
| | TKIP | | |
| EAP-TLS | AES | | - |
| | TKIP | | - |

For example:

| Network Name (SSID) |
|---------------------|
| HELLO |

| Authentication Method | Encryption Mode | User ID | Password |
|-----------------------|-----------------|---------|----------|
| EAP-FAST/MS-CHAPv2 | AES | Brother | 12345678 |



- If you configure your machine using EAP-TLS authentication, you must install the client certificate issued by a CA before you start configuration. Contact your network administrator about the client certificate. If you have installed more than one certificate, we recommend writing down the certificate name you want to use.
- If you verify your machine using the common name of the server certificate, we recommend writing down the common name before you start configuration. Contact your network administrator about the common name of the server certificate.

2. Press  [Settings] > [Network] > [WLAN (Wi-Fi)] > [Find Wi-Fi Network].
3. When [Enable WLAN?] appears, press [Yes].
The wireless setup wizard starts. To cancel, press [No].

4. The machine searches for your network and displays a list of available SSIDs. Press ▲ or ▼ to display the [<New SSID>] option, and then press it.
5. Press [OK].
6. Enter the SSID name, and then press [OK].



For more information about how to enter text, see *Related Information*.

7. Select the Authentication Method, and then press it.
8. Do one of the following:
 - If you selected the [EAP-FAST], [PEAP] or [EAP-TTLS] option, select the Inner Authentication method [NONE], [CHAP], [MS-CHAP], [MS-CHAPv2], [GTC] or [PAP].



Depending on your Authentication method, the Inner Authentication method selections differ.

Select the encryption type [TKIP+AES] or [AES].

Select the verification method [No Verification], [CA] or [CA + Server ID].

- If you selected the [CA + Server ID] option, enter the server ID, user ID and password (if required), and then press [OK] for each option.
- For other selections, enter the user ID and Password, and then press [OK] for each option.



If you have not imported a CA certificate into your machine, the machine displays [No Verification].

- If you selected the [EAP-TLS] option, select the encryption type [TKIP+AES] or [AES].
The machine will display a list of available Client Certificates, and then select the certificate.
Select the verification method [No Verification], [CA] or [CA + Server ID].
 - If you selected the [CA + Server ID] option, enter the server ID and user ID, and then press [OK] for each option.
 - For other selections, enter the user ID, and then press [OK].

9. The machine attempts to connect to the wireless device you have selected.

If your wireless device is connected successfully, the LCD displays [Connected].

You have completed the wireless network setup. To install the drivers or your application necessary for operating your device, go to your model's **Downloads** page at <https://s.brother/ca2ab/>.



Related Information

- [Use the Wireless Network](#)

Related Topics:

- [Enter Text on Your Brother Machine](#)
-

Use Wi-Fi Direct®

- [Wi-Fi Direct Overview](#)
- [Configure Your Wi-Fi Direct Network Using the Push Button Method](#)
- [Configure a Wi-Fi Direct Network Manually](#)
- [If You Are Having Difficulty with Your Machine's Network](#)

Wi-Fi Direct Overview

Wi-Fi Direct is one of the wireless configuration methods developed by the Wi-Fi Alliance®. It allows you to securely connect your mobile device to your Brother machine without using a wireless router/access point.

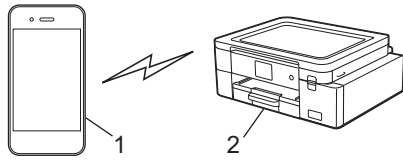

1. Mobile device
2. Your Brother machine



-
- You can use Wi-Fi Direct with either the wired or wireless network connection at the same time.
 - The Wi-Fi Direct supported device can become a Group Owner. When configuring the Wi-Fi Direct network, the Group Owner serves as an access point.
-



Related Information

- [Use Wi-Fi Direct®](#)

Related Topics:

- [Configure Your Wi-Fi Direct Network Using the Push Button Method](#)
 - [Configure a Wi-Fi Direct Network Manually](#)
-

Configure Your Wi-Fi Direct Network Using the Push Button Method



When the machine receives the Wi-Fi Direct request from your mobile device, the message [Wi-Fi Direct connection request received. Press [OK] to connect.] will appear on the LCD. Press [OK] to connect.

1. Press  [Settings] > [Network] > [Wi-Fi Direct].
2. If your mobile device does not support Wi-Fi Direct, press [Group Owner] > [On].
3. Press [Push Button].
4. When the [Activate Wi-Fi Direct on other device. Then Press [OK].] message appears, turn your mobile device's Wi-Fi Direct function on (for more information, see your mobile device's user's guide). Press [OK] on your Brother machine.
5. Do one of the following:
 - If your mobile device displays a list of machines with Wi-Fi Direct enabled, select your Brother machine.
 - If your Brother machine displays a list of mobile devices with Wi-Fi Direct enabled, select your mobile device. To search for available devices again, press [Rescan].

When your mobile device connects successfully, the machine displays [Connected].



Related Information

- [Use Wi-Fi Direct®](#)

Related Topics:

- [Wi-Fi Direct Overview](#)
 - [Configure a Wi-Fi Direct Network Manually](#)
-

Configure a Wi-Fi Direct Network Manually

Configure the Wi-Fi Direct setting from the machine's control panel.

1. Press  [Settings] > [Network] > [Wi-Fi Direct] > [Manual].
2. The machine will display the SSID (Network Name) and Password (Network Key). Go to your mobile device's wireless network settings screen, select the SSID, and then enter the password.

When your mobile device connects successfully, the machine displays [Connected].



Related Information

- [Use Wi-Fi Direct®](#)

Related Topics:

- [Wi-Fi Direct Overview](#)
 - [Configure Your Wi-Fi Direct Network Using the Push Button Method](#)
-

Enable/Disable Wireless LAN

1. Press  [Settings] > [Network] > [Network I/F].
2. Do one of the following:
 - To enable Wi-Fi, select [WLAN (Wi-Fi)].
 - To disable Wi-Fi, select [Wired LAN].
3. Press .

Related Information

- [Wireless Network Settings](#)
-

Print the WLAN Report

The WLAN Report shows your machine's wireless status. If the wireless connection fails, check the error code on the printed report.

1. Press  [Settings] > [All Settings] > [Print Reports] > [WLAN Report] > [Yes].

The machine will print the WLAN Report.

If the WLAN Report does not print, check your machine for errors. If there are no visible errors, wait for one minute and then try to print the report again.

Related Information

- [Wireless Network Settings](#)
 - [Wireless LAN Report Error Codes](#)

Related Topics:

- [If You Are Having Difficulty with Your Machine's Network](#)
 - [Configure IEEE 802.1x Authentication for a Wired or a Wireless Network Using Web Based Management \(Web Browser\)](#)
-

Wireless LAN Report Error Codes

If the Wireless LAN Report shows that the connection failed, check the error code on the printed report and see the corresponding instructions in the table:

| Error Code | Problem and Recommended Solutions |
|------------|---|
| TS-01 | <p>The WLAN (Wi-Fi) is not enabled.</p> <p>Check the following points and try to set up your wireless connection again:</p> <ul style="list-style-type: none"> • Enable the WLAN setting on your machine. • If a network cable is connected to your machine, disconnect it. |
| TS-02 | <p>The wireless router/access point cannot be detected.</p> <p>Check the following points and try to set up your wireless connection again:</p> <ul style="list-style-type: none"> • Make sure the wireless router/access point is on. • Temporarily place your machine closer to the wireless router/access point when you are configuring the wireless settings. • If your wireless router/access point is using MAC address filtering, confirm that the MAC address of the machine is allowed in the filter. You can find the MAC address by printing the Network Configuration Report. • If you manually entered the Network Name (SSID) and security information (authentication method/encryption method), the information may be incorrect. Check the Network Name and security information again and re-enter the correct information. • Restart your wireless router/access point. If you cannot find the Network Name (SSID) and security information, see the documentation provided with your wireless router/access point, or contact the router manufacturer, your system administrator, or Internet service provider. |
| TS-03 | <p>The wireless enterprise network and security settings you entered may be incorrect.</p> <p>Check the following points and try to set up your wireless connection again:</p> <p>Verify the following information:</p> <ul style="list-style-type: none"> - Network Name (SSID) you selected to configure your machine. - Security information you selected to configure your machine (such as the authentication method, encryption method, or User ID). <p>If you still cannot find the Network Name (SSID) and security information, see the documentation provided with your wireless router/access point, or contact the router manufacturer, your system administrator, or Internet service provider.</p> |
| TS-04 | <p>Your machine does not support the authentication and encryption methods used by the selected wireless router/access point.</p> <p>For infrastructure mode (Most common)</p> <p>Change the authentication and encryption methods of the wireless router/access point. Your machine supports the following authentication and encryption methods:</p> <ul style="list-style-type: none"> • WPA-Personal: TKIP / AES • WPA2-Personal: TKIP / AES • Open: WEP / NONE (without encryption) • Shared key: WEP <p>If your issue is not solved, the Network Name (SSID) or security settings you entered may be incorrect. Check that all wireless network settings are correct for your network.</p> |
| TS-05 | <p>The Network Name (SSID) and Network Key (Password) are incorrect.</p> <p>Check the following points and try to set up your wireless connection again:</p> <ul style="list-style-type: none"> • Confirm the Network Name (SSID) and Network Key (Password). • If your Network Key contains upper-case and lower-case letters, make sure you type them correctly. • If you cannot find the Network Name (SSID) and security information, see the documentation provided with your wireless router/access point, or contact the router manufacturer, your system administrator, or Internet service provider. • If your wireless router/access point uses WEP encryption with multiple WEP keys, write down and use only the first WEP key. |

| Error Code | Problem and Recommended Solutions |
|------------|--|
| TS-06 | <p>The wireless security information (authentication method/encryption method/Network Key (Password)) is incorrect.</p> <p>Check the following points and try to set up your wireless connection again:</p> <ul style="list-style-type: none"> • Confirm the Network Key. If your Network Key contains upper-case and lower-case letters, make sure you type them correctly. • Confirm whether the authentication method entered and the authentication method or encryption method supported by the wireless router/access point are the same. • If the network key, authentication method, and encryption method have been confirmed, restart your wireless router/access point and the machine. • If your wireless router/access point's Stealth Mode is on, you may need to disable it to connect to the wireless network. <p>If you cannot find the Network Name (SSID) and security information, see the documentation provided with your wireless router/access point, or contact the router manufacturer, your system administrator, or Internet service provider.</p> |
| TS-07 | <p>The machine cannot detect a wireless router/access point that has WPS (Wi-Fi Protected Setup) enabled.</p> <p>Check the following points and try again:</p> <ul style="list-style-type: none"> • To check if your wireless router/access point supports WPS, look for the WPS symbol displayed on the router/access point. For more information, see the documentation provided with your wireless router/access point. • To set up your wireless connection using WPS, you must configure both your machine and the wireless router/access point. For more information, see the user's guide. • If you do not know how to set up your wireless router/access point using WPS, see the documentation provided with your wireless router/access point, or contact the router manufacturer, your system administrator, or Internet service provider. |
| TS-08 | <p>Two or more wireless routers or access points that have WPS enabled are detected. Check the following points and try again:</p> <ul style="list-style-type: none"> • Make sure that only one wireless router/access point within range has WPS enabled, and then try to connect again. • Try to connect again after a few minutes to avoid interference from other access points/routers. |



How to confirm wireless security information (SSID/authentication method/encryption method/Network Key) of your WLAN access point/router:

1. The default security settings may be provided on a label attached to the WLAN access point/router. Or the manufacturer's name or model number of the WLAN access point/router may be used as the default security settings.
2. See the documentation provided with your WLAN access point/router for information on how to find the security settings.
 - If the WLAN access point/router is set to not broadcast the SSID, the SSID will not automatically be detected. You will have to manually enter the SSID name.
 - The Network key may also be described as the Password, Security Key, or Encryption Key.

If you do not know the SSID and wireless security settings of your WLAN access point/router or how to change the configuration, see the documentation provided with your WLAN access point/router, ask the manufacturer of your access point/router or ask your Internet provider or network administrator.



Related Information

- [Print the WLAN Report](#)

Related Topics:

- [If You Are Having Difficulty with Your Machine's Network](#)

Network Features

- [Print the Network Configuration Report](#)
- [Reset the Network Settings to Factory Default](#)

Print the Network Configuration Report

The Network Configuration Report lists the network configuration, including the network print server settings.



- **Node Name:** The Node Name appears on the current Network Configuration Report. The default Node Name is "BRN123456abcdef" for a wired network or "BRW123456abcdef" for a wireless network (where "123456abcdef" is your machine's MAC Address / Ethernet Address.)
- If the IP Address on the Network Configuration Report shows 0.0.0.0, wait for one minute and try printing it again.
- You can find your machine's settings, such as the IP address, subnet mask, node name, and MAC Address on the report, for example:
 - IP address: 192.168.0.5
 - Subnet mask: 255.255.255.0
 - Node name: BRN000ca0000499
 - MAC Address: 00-0c-a0-00-04-99

1. Press  [Settings] > [All Settings] > [Print Reports] > [Network Configuration] > [Yes].

The machine prints the current Network Configuration Report.



Related Information

- [Network Features](#)

Related Topics:

- [If You Are Having Difficulty with Your Machine's Network](#)
 - [Configure IEEE 802.1x Authentication for a Wired or a Wireless Network Using Web Based Management \(Web Browser\)](#)
 - [Error and Maintenance Messages](#)
-

Reset the Network Settings to Factory Default

You can use your machine's control panel to reset the print server to its default factory settings. This resets all information, such as the password and IP address.



- This feature restores all wired (supported models only) and wireless network settings to the factory settings.
 - You can also reset the print server to its factory settings using Web Based Management.
-

1. Press  [Settings] > [All Settings] > [Network] > [Network Reset].
2. The reset confirmation message is displayed. Press [OK] for two seconds.
The machine will restart.



Related Information

- [Network Features](#)
-

Security

- [Before Using Network Security Features](#)
- [Configure Certificates for Device Security](#)
- [Use SSL/TLS](#)
- [Use SNMPv3](#)
- [Use IPsec](#)
- [Use IEEE 802.1x Authentication for a Wired or a Wireless Network](#)
- [Send an Email Securely](#)

Before Using Network Security Features

Your machine employs some of the latest network security and encryption protocols available today. These network features can be integrated into your overall network security plan to help protect your data and prevent unauthorized access to the machine.



We recommend disabling the FTP and TFTP protocols. Accessing the machine using these protocols is not secure.



Related Information

- [Security](#)
-

Configure Certificates for Device Security

You must configure a certificate to manage your networked machine securely using SSL/TLS. You must use Web Based Management to configure a certificate.

- [Supported Security Certificate Features](#)
- [Step by Step Guide for Creating and Installing a Certificate](#)
- [Create a Self-signed Certificate](#)
- [Create CSR and Install a Certificate from a Certificate Authority \(CA\)](#)
- [Import and Export the Certificate and Private Key](#)
- [Import and Export a CA Certificate](#)
- [Manage Multiple Certificates](#)

Supported Security Certificate Features

Your machine supports the use of multiple security certificates, which allows secure authentication and communication with the machine. The following security certificate features can be used with the machine:

- SSL/TLS communication
- IEEE 802.1x authentication
- IPsec

The Brother machine supports the following:

- Pre-installed certificate

Your machine has a pre-installed self-signed certificate. This certificate enables you to use SSL/TLS communication without creating or installing a different certificate.



The pre-installed self-signed certificate protects your communication up to a certain level. We recommend using a certificate that is issued by a trusted organization for better security.

- Self-signed certificate

This print server issues its own certificate. Using this certificate, you can easily use the SSL/TLS communication without creating or installing a different certificate from a CA.

- Certificate from a Certificate Authority (CA)

There are two methods for installing a certificate from a CA. If you already have a certificate from a CA or if you want to use a certificate from an external trusted CA:

- When using a Certificate Signing Request (CSR) from this print server.
- When importing a certificate and a private key.

- Certificate Authority (CA) Certificate

To use a CA certificate that identifies the CA and owns its private key, you must import that CA certificate from the CA before configuring the security features of the Network.



- If you are going to use SSL/TLS communication, we recommend contacting your system administrator first.
 - When you reset the print server back to its default factory settings, the certificate and the private key that are installed will be deleted. If you want to keep the same certificate and the private key after resetting the print server, export them before resetting, and then reinstall them.
-



Related Information

- [Configure Certificates for Device Security](#)

Related Topics:

- [Configure IEEE 802.1x Authentication for a Wired or a Wireless Network Using Web Based Management \(Web Browser\)](#)
-

Step by Step Guide for Creating and Installing a Certificate

There are two options when choosing a security certificate: use a self-signed certificate or use a certificate from a Certificate Authority (CA).

Option 1

Self-Signed Certificate

1. Create a self-signed certificate using Web Based Management.
2. Install the self-signed certificate on your computer.

Option 2

Certificate from a CA

1. Create a Certificate Signing Request (CSR) using Web Based Management.
2. Install the certificate issued by the CA on your Brother machine using Web Based Management.
3. Install the certificate on your computer.



Related Information

- [Configure Certificates for Device Security](#)
-

Create a Self-signed Certificate

1. Start your web browser.
2. Type "https://machine's IP address" in your browser's address bar (where "machine's IP address" is the machine's IP address).

For example:

https://192.168.1.2



If you are using a Domain Name System or enable a NetBIOS name, you can type another name, such as "SharedPrinter" instead of the IP address.

For example:

https://SharedPrinter

If you enable a NetBIOS name, you can also use the node name.

For example:

https://brn123456abcdef

The NetBIOS name can be found in the Network Configuration Report.

3. If required, type the password in the **Login** field, and then click **Login**.



The default password to manage this machine's settings is located on the back of the machine and marked "Pwd".

4. Go to the navigation menu, and then click **Network > Security > Certificate**.



Start from , if the navigation menu is not shown on the left side of the screen.

5. Click **Create Self-Signed Certificate**.
6. Enter a **Common Name** and a **Valid Date**.
 - The length of the **Common Name** is less than 64 bytes. Enter an identifier, such as an IP address, node name, or domain name to use when accessing this machine through SSL/TLS communication. The node name is displayed by default.
 - A warning will appear if you use the IPPS or HTTPS protocol and enter a different name in the URL than the **Common Name** that was used for the self-signed certificate.
7. Select your setting from the **Public Key Algorithm** drop-down list. The default setting is **RSA(2048bit)**.
8. Select your setting from the **Digest Algorithm** drop-down list. The default setting is **SHA256**.
9. Click **Submit**.



Related Information

- [Configure Certificates for Device Security](#)

Related Topics:

- [Access Web Based Management](#)
-

Create CSR and Install a Certificate from a Certificate Authority (CA)

If you already have a certificate from an external trusted CA, you can store the certificate and private key on the machine and manage them by importing and exporting. If you do not have a certificate from an external trusted CA, create a Certificate Signing Request (CSR), send it to a CA for authentication, and install the returned certificate on your machine.

- [Create a Certificate Signing Request \(CSR\)](#)
- [Install a Certificate on Your Machine](#)

Create a Certificate Signing Request (CSR)

A Certificate Signing Request (CSR) is a request sent to a Certificate Authority (CA) to authenticate the credentials contained within the certificate.

We recommend installing a Root Certificate from the CA on your computer before creating the CSR.

1. Start your web browser.
2. Type "https://machine's IP address" in your browser's address bar (where "machine's IP address" is the machine's IP address).
For example:
https://192.168.1.2



If you are using a Domain Name System or enable a NetBIOS name, you can type another name, such as "SharedPrinter" instead of the IP address.

For example:

https://SharedPrinter

If you enable a NetBIOS name, you can also use the node name.

For example:

https://brn123456abcdef

The NetBIOS name can be found in the Network Configuration Report.

3. If required, type the password in the **Login** field, and then click **Login**.



The default password to manage this machine's settings is located on the back of the machine and marked "**Pwd**".

4. Go to the navigation menu, and then click **Network > Security > Certificate**.



Start from , if the navigation menu is not shown on the left side of the screen.

5. Click **Create CSR**.
6. Type a **Common Name** (required) and add other information about your **Organization** (optional).



- Your company details are required so that a CA can confirm your identity and verify it to the outside world.
- The length of the **Common Name** must be less than 64 bytes. Enter an identifier, such as an IP address, node name, or domain name to use when accessing this printer through SSL/TLS communication. The node name is displayed by default. The **Common Name** is required.
- A warning will appear if you type a different name in the URL than the Common Name that was used for the certificate.
- The length of the **Organization**, the **Organization Unit**, the **City/Locality** and the **State/Province** must be less than 64 bytes.
- The **Country/Region** should be a two character ISO 3166 country code.
- If you are configuring an X.509v3 certificate extension, select the **Configure extended partition** checkbox, and then select **Auto (Register IPv4)** or **Manual**.

7. Select your setting from the **Public Key Algorithm** drop-down list. The default setting is **RSA(2048bit)**.
8. Select your setting from the **Digest Algorithm** drop-down list. The default setting is **SHA256**.
9. Click **Submit**.

The CSR appears on your screen. Save the CSR as a file or copy and paste it into an online CSR form offered by a Certificate Authority.

10. Click **Save**.



- Follow your CA's policy regarding the method to send a CSR to your CA.
- If you are using the Enterprise root CA of Windows Server 2008/2008 R2/2012/2012 R2/2016/2019, we recommend using the Web Server for the certificate template to securely create the Client Certificate. If you are creating a Client Certificate for an IEEE 802.1x environment with EAP-TLS authentication, we recommend using User for the certificate template.

For more detailed information, visit <https://s.brother/cf2ab/> to find more answers on your model's **FAQs & Troubleshooting** page.

Search for "SSL".



Related Information

- [Create CSR and Install a Certificate from a Certificate Authority \(CA\)](#)

Related Topics:

- [Access Web Based Management](#)
-

Install a Certificate on Your Machine

When you receive a certificate from a CA, follow the steps below to install it into the print server:

Only a certificate issued with your machine's CSR can be installed onto the machine. When you want to create another CSR, make sure that the certificate is installed before creating another CSR. Create another CSR only after installing the certificate on the machine. If you do not, the CSR you create before installing will be invalid.

1. Start your web browser.
2. Type "https://machine's IP address" in your browser's address bar (where "machine's IP address" is the machine's IP address).
For example:
https://192.168.1.2

 If you are using a Domain Name System or enable a NetBIOS name, you can type another name, such as "SharedPrinter" instead of the IP address.

For example:

https://SharedPrinter

If you enable a NetBIOS name, you can also use the node name.

For example:



https://brn123456abcdef

The NetBIOS name can be found in the Network Configuration Report.

3. If required, type the password in the **Login** field, and then click **Login**.

 The default password to manage this machine's settings is located on the back of the machine and marked "Pwd".

4. Go to the navigation menu, and then click **Network > Security > Certificate**.

 Start from , if the navigation menu is not shown on the left side of the screen.

5. Click **Install Certificate**.
6. Browse to the file that contains the certificate issued by the CA, and then click **Submit**.
The certificate has been created successfully and saved in your machine's memory successfully.

To use SSL/TLS communication, the Root Certificate from the CA must be installed on your computer. Contact your network administrator.

Related Information

- [Create CSR and Install a Certificate from a Certificate Authority \(CA\)](#)

Related Topics:

- [Access Web Based Management](#)
-

Import and Export the Certificate and Private Key

Store the certificate and private key on your machine and manage them by importing and exporting them.

- [Import a Certificate and Private Key](#)
- [Export the Certificate and Private Key](#)

Import a Certificate and Private Key

1. Start your web browser.
2. Type "https://machine's IP address" in your browser's address bar (where "machine's IP address" is the machine's IP address).

For example:

https://192.168.1.2



If you are using a Domain Name System or enable a NetBIOS name, you can type another name, such as "SharedPrinter" instead of the IP address.

For example:

https://SharedPrinter

If you enable a NetBIOS name, you can also use the node name.

For example:

https://brn123456abcdef

The NetBIOS name can be found in the Network Configuration Report.

3. If required, type the password in the **Login** field, and then click **Login**.



The default password to manage this machine's settings is located on the back of the machine and marked "Pwd".

4. Go to the navigation menu, and then click **Network > Security > Certificate**.



Start from , if the navigation menu is not shown on the left side of the screen.

5. Click **Import Certificate and Private Key**.
6. Browse to the file you want to import.
7. Type the password if the file is encrypted, and then click **Submit**.

The certificate and private key are imported to your machine.



Related Information

- [Import and Export the Certificate and Private Key](#)

Related Topics:

- [Access Web Based Management](#)
-

Export the Certificate and Private Key

1. Start your web browser.
2. Type "https://machine's IP address" in your browser's address bar (where "machine's IP address" is the machine's IP address).

For example:

https://192.168.1.2



If you are using a Domain Name System or enable a NetBIOS name, you can type another name, such as "SharedPrinter" instead of the IP address.

For example:

https://SharedPrinter

If you enable a NetBIOS name, you can also use the node name.

For example:

https://brn123456abcdef

The NetBIOS name can be found in the Network Configuration Report.

3. If required, type the password in the **Login** field, and then click **Login**.



The default password to manage this machine's settings is located on the back of the machine and marked "Pwd".

4. Go to the navigation menu, and then click **Network > Security > Certificate**.



Start from , if the navigation menu is not shown on the left side of the screen.

5. Click **Export** shown with **Certificate List**.
6. Enter the password if you want to encrypt the file.
If a blank password is used, the output is not encrypted.
7. Enter the password again for confirmation, and then click **Submit**.
8. Click **Save**.

The certificate and private key are exported to your computer.

You can also import the certificate to your computer.



Related Information

- [Import and Export the Certificate and Private Key](#)

Related Topics:

- [Access Web Based Management](#)
-

Import and Export a CA Certificate

You can import, export and store CA certificates on your Brother machine.

- [Import a CA Certificate](#)
- [Export a CA Certificate](#)

Import a CA Certificate

1. Start your web browser.
2. Type "https://machine's IP address" in your browser's address bar (where "machine's IP address" is the machine's IP address).

For example:

https://192.168.1.2



If you are using a Domain Name System or enable a NetBIOS name, you can type another name, such as "SharedPrinter" instead of the IP address.

For example:

https://SharedPrinter

If you enable a NetBIOS name, you can also use the node name.

For example:

https://brn123456abcdef

The NetBIOS name can be found in the Network Configuration Report.

3. If required, type the password in the **Login** field, and then click **Login**.



The default password to manage this machine's settings is located on the back of the machine and marked "Pwd".

4. Go to the navigation menu, and then click **Network > Security > CA Certificate**.



Start from ☰, if the navigation menu is not shown on the left side of the screen.

5. Click **Import CA Certificate**.
6. Browse to the file you want to import.
7. Click **Submit**.



Related Information

- [Import and Export a CA Certificate](#)

Related Topics:

- [Access Web Based Management](#)
-

Export a CA Certificate

1. Start your web browser.
2. Type "https://machine's IP address" in your browser's address bar (where "machine's IP address" is the machine's IP address).

For example:

https://192.168.1.2



If you are using a Domain Name System or enable a NetBIOS name, you can type another name, such as "SharedPrinter" instead of the IP address.

For example:

https://SharedPrinter

If you enable a NetBIOS name, you can also use the node name.

For example:

https://brn123456abcdef

The NetBIOS name can be found in the Network Configuration Report.

3. If required, type the password in the **Login** field, and then click **Login**.



The default password to manage this machine's settings is located on the back of the machine and marked "Pwd".

4. Go to the navigation menu, and then click **Network > Security > CA Certificate**.



Start from , if the navigation menu is not shown on the left side of the screen.

5. Select the certificate you want to export and click **Export**.
6. Click **Submit**.
7. Click ▼ next to **Save**, and then specify the location where you want to save the file.



Related Information

- [Import and Export a CA Certificate](#)

Related Topics:

- [Access Web Based Management](#)
-

Manage Multiple Certificates

The multiple certificate feature allows you to use Web Based Management to manage each certificate installed on your machine. In Web Based Management, navigate to the **Certificate** or **CA Certificate** screen to view certificate content, delete, or export your certificates.

| | Maximum Number of Certificates Stored on Brother Machine |
|---|--|
| Self-signed Certificate or Certificate Issued by a CA | 5 |
| CA Certificate | 6 |

We recommend storing fewer certificates than allowed, reserving an empty spot in case of certificate expiration. When a certificate expires, import a new certificate into the reserved spot, and then delete the expired certificate. This ensures that you avoid configuration failure.



- When you use HTTPS/IPPS or IEEE 802.1x, you must select which certificate you are using.
- When you use SSL for SMTP communications, you do not have to choose the certificate. The necessary certificate will be chosen automatically.



Related Information

- [Configure Certificates for Device Security](#)

Use SSL/TLS

- [Introduction to SSL/TLS](#)
- [Manage Your Network Machine Securely Using SSL/TLS](#)
- [Print Documents Securely Using SSL/TLS](#)
- [Send an Email Securely Using SSL/TLS](#)

Introduction to SSL/TLS

Secure Socket Layer (SSL) or Transport Layer Security (TLS) is an effective method of protecting data sent over a local or wide area network (LAN or WAN). It works by encrypting data, such as a print job, sent over a network, so anyone trying to capture it will not be able to read it.

SSL/TLS can be configured on both wired and wireless networks and will work with other forms of security such as WPA keys and firewalls.



Related Information

- [Use SSL/TLS](#)
 - [Brief History of SSL/TLS](#)
 - [Benefits of Using SSL/TLS](#)
-

Brief History of SSL/TLS

SSL/TLS was originally created to secure web traffic information, particularly data sent between web browsers and servers. For example, when you use Internet Explorer for Internet Banking and you see https:// and the little padlock icon in the web browser, you are using SSL. SSL grew to work with additional applications, such as Telnet, printer, and FTP software, in order to become a universal solution for online security. Its original design intentions are still being used today by many online retailers and banks to secure sensitive data, such as credit card numbers, customer records, etc.

SSL/TLS uses extremely high levels of encryption and is trusted by banks all over the world.



Related Information

- [Introduction to SSL/TLS](#)

Benefits of Using SSL/TLS

The primary benefit of using SSL/TLS is to guarantee secure printing over an IP network by restricting unauthorized users from reading data sent to the machine. SSL's key selling point is that it can be used to print confidential data securely. For example, an HR department in a large company may be printing wage slips on a regular basis. Without encryption, the data contained on these wages slips can be read by other network users. However, with SSL/TLS, anyone trying to capture the data will see a confusing page of code and not the actual wage slip.



Related Information

- [Introduction to SSL/TLS](#)

Manage Your Network Machine Securely Using SSL/TLS

- [Configure a Certificate for SSL/TLS and Available Protocols](#)
- [Access Web Based Management Using SSL/TLS](#)
- [Install the Self-signed Certificate for Windows Users as Administrators](#)
- [Configure Certificates for Device Security](#)

Configure a Certificate for SSL/TLS and Available Protocols

Configure a certificate on your machine using Web Based Management before you use SSL/TLS communication.

1. Start your web browser.
2. Type "https://machine's IP address" in your browser's address bar (where "machine's IP address" is the machine's IP address).

For example:

https://192.168.1.2



If you are using a Domain Name System or enable a NetBIOS name, you can type another name, such as "SharedPrinter" instead of the IP address.

For example:

https://SharedPrinter

If you enable a NetBIOS name, you can also use the node name.

For example:

https://brn123456abcdef

The NetBIOS name can be found in the Network Configuration Report.

3. If required, type the password in the **Login** field, and then click **Login**.



The default password to manage this machine's settings is located on the back of the machine and marked "Pwd".

4. Go to the navigation menu, and then click **Network > Network > Protocol**.



Start from , if the navigation menu is not shown on the left side of the screen.

5. Click **HTTP Server Settings**.
6. Select the certificate you want to configure from the **Select the Certificate** drop-down list.
7. Click **Submit**.
8. Click **Yes** to restart your print server.



Related Information

- [Manage Your Network Machine Securely Using SSL/TLS](#)

Related Topics:

- [Access Web Based Management](#)
 - [Print Documents Securely Using SSL/TLS](#)
-

Access Web Based Management Using SSL/TLS

To manage your network machine securely, you must use management utilities with security protocols.



- To use HTTPS protocol, HTTPS must be enabled on your machine. The HTTPS protocol is enabled by default.
- You can change the HTTPS protocol settings using the Web Based Management screen.

1. Start your web browser.
2. Type "https://machine's IP address" in your browser's address bar (where "machine's IP address" is the machine's IP address).

For example:

https://192.168.1.2

3. If required, type the password in the **Login** field, and then click **Login**.



The default password to manage this machine's settings is located on the back of the machine and marked "**Pwd**".

4. You can now access the machine using HTTPS.



Related Information

- [Manage Your Network Machine Securely Using SSL/TLS](#)

Related Topics:

- [Access Web Based Management](#)
-

Install the Self-signed Certificate for Windows Users as Administrators

- The following steps are for Microsoft Edge. If you use another web browser, refer to your web browser's documentation or online help for instructions on how to install certificates.
- Make sure you have created your self-signed certificate using Web Based Management.

1. Right-click the **Microsoft Edge** icon, and then click **Run as administrator**.
If the **User Account Control** screen appears, click **Yes**.
2. Type "https://machine's IP address" in your browser's address bar (where "machine's IP address" is the machine's IP address).
For example:
https://192.168.1.2



If you are using a Domain Name System or enable a NetBIOS name, you can type another name, such as "SharedPrinter" instead of the IP address.

For example:

https://SharedPrinter

If you enable a NetBIOS name, you can also use the node name.

For example:

https://brn123456abcdef

The NetBIOS name can be found in the Network Configuration Report.

3. If your connection is not private, click the **Advanced** button, and then continue to the web page.
4. If required, type the password in the **Login** field, and then click **Login**.



The default password to manage this machine's settings is located on the back of the machine and marked "Pwd".

5. Go to the navigation menu, and then click **Network > Security > Certificate**.



Start from , if the navigation menu is not shown on the left side of the screen.

6. Click **Export**.
7. To encrypt the output file, type a password in the **Enter password** field. If the Enter password field is blank, your output file will not be encrypted.
8. Type the password again in the **Retype password** field, and then click **Submit**.
9. Click the downloaded file to open.
10. When the **Certificate Import Wizard** appears, click **Next**.
11. Select **Place all certificates in the following store**, and then click **Browse...**
12. Select **Trusted Root Certification Authorities**, and then click **OK**.
13. Click **Next**.
14. Click **Finish**.
15. Click **Yes**, if the fingerprint (thumbprint) is correct.
16. Click **OK**.



Related Information

- [Manage Your Network Machine Securely Using SSL/TLS](#)

Print Documents Securely Using SSL/TLS

- [Print Documents Using SSL/TLS](#)
- [Configure Certificates for Device Security](#)
- [Configure a Certificate for SSL/TLS and Available Protocols](#)

Print Documents Using SSL/TLS

To print documents securely with IPP protocol, use the IPPS protocol.

1. Start your web browser.
2. Type "https://machine's IP address" in your browser's address bar (where "machine's IP address" is the machine's IP address).

For example:

https://192.168.1.2



If you are using a Domain Name System or enable a NetBIOS name, you can type another name, such as "SharedPrinter" instead of the IP address.

For example:

https://SharedPrinter

If you enable a NetBIOS name, you can also use the node name.

For example:

https://brn123456abcdef

The NetBIOS name can be found in the Network Configuration Report.

3. If required, type the password in the **Login** field, and then click **Login**.



The default password to manage this machine's settings is located on the back of the machine and marked "**Pwd**".

4. Go to the navigation menu, and then click **Network > Network > Protocol**.



Start from , if the navigation menu is not shown on the left side of the screen.

5. Make sure the **IPP** checkbox is selected.



If the **IPP** checkbox is not selected, select the **IPP** checkbox, and then click **Submit**.

Restart your machine to activate the configuration.

After the machine restarts, return to the machine's web page, type the password, go to the navigation menu, and then click **Network > Network > Protocol**.

6. Click **HTTP Server Settings**.
7. Select the **HTTPS (Port 443)** checkbox in the **IPP**, and then click **Submit**.
8. Restart your machine to activate the configuration.

Communication using IPPS cannot prevent unauthorized access to the print server.



Related Information

- [Print Documents Securely Using SSL/TLS](#)

Related Topics:

- [Access Web Based Management](#)
-

Use SNMPv3

- [Manage Your Network Machine Securely Using SNMPv3](#)

Manage Your Network Machine Securely Using SNMPv3

The Simple Network Management Protocol version 3 (SNMPv3) provides user authentication and data encryption to manage network devices securely.

1. Start your web browser.
2. Type "https://machine's IP address" in your browser's address bar (where "machine's IP address" is the machine's IP address).

For example:

https://192.168.1.2

3. If required, type the password in the **Login** field, and then click **Login**.





The default password to manage this machine's settings is located on the back of the machine and marked "**Pwd**".

4. Go to the navigation menu, and then click **Network > Network > Protocol**.



Start from , if the navigation menu is not shown on the left side of the screen.

5. Make sure the **SNMP** setting is enabled, and then click **Advanced Settings**.
6. Configure the SNMP settings. There are three options for **SNMP Mode of Operation**.

| Option | Description |
|---|--|
| SNMP v1/v2c read-write access | The print server uses version 1 and version 2c of the SNMP protocol. You can use all Brother applications in this mode. However, it is not secure since it will not authenticate the user, and data will not be encrypted. |
| SNMPv3 read-write access and v1/v2c read-only access | The print server uses the read-write access of version 3 and the read-only access of version 1 and version 2c of the SNMP protocol.  When you use SNMPv3 read-write access and v1/v2c read-only access mode, some Brother applications that access the print server do not work correctly since they authorize the read-only access of version 1 and version 2c. If you want to use all applications, we recommend using the SNMP v1/v2c read-write access mode. |
| SNMPv3 read-write access | The print server uses version 3 of the SNMP protocol. If you want to manage the print server securely, use this mode.  When you use the SNMPv3 read-write access mode, note the following: <ul style="list-style-type: none">• You can use only Web Based Management to manage the print server• All applications that use SNMPv1/v2c will be restricted. To allow the use of SNMPv1/v2c applications, use the SNMPv3 read-write access and v1/v2c read-only access or SNMP v1/v2c read-write access mode. |

7. Click **Submit**.



Related Information

- [Use SNMPv3](#)

Related Topics:

- [Access Web Based Management](#)

Use IPsec

- [Introduction to IPsec](#)
- [Configure IPsec Using Web Based Management](#)
- [Configure an IPsec Address Template Using Web Based Management](#)
- [Configure IPsec Using Web Based Management](#)

Introduction to IPsec

IPsec (Internet Protocol Security) is a security protocol that uses an optional Internet Protocol function to prevent data manipulation and ensure the confidentiality of data transmitted as IP packets. IPsec encrypts data carried over the network, such as print data sent from computers to a printer. Because the data is encrypted at the network layer, applications that employ a higher-level protocol use IPsec even if the user is not aware of its use.

IPsec supports the following functions:

- IPsec transmissions

According to the IPsec setting conditions, the network-connected computer sends data to and receives data from the specified device using IPsec. When the devices start communicating using IPsec, keys are exchanged using Internet Key Exchange (IKE) first, and then the encrypted data is transmitted using the keys.

In addition, IPsec has two operation modes: the Transport mode and Tunnel mode. The Transport mode is used mainly for communication between devices and the Tunnel mode is used in environments such as a Virtual Private Network (VPN).



For IPsec transmissions, the following conditions are necessary:

- A computer that can communicate using IPsec is connected to the network.
- Your machine is configured for IPsec communication.
- The computer connected to your machine is configured for IPsec connections.

- IPsec settings

The settings that are necessary for connections using IPsec. These settings can be configured using Web Based Management.



To configure the IPsec settings, you must use the browser on a computer that is connected to the network.



Related Information

- [Use IPsec](#)
-

Configure IPsec Using Web Based Management

The IPsec connection conditions comprise two **Template** types: **Address** and **IPsec**. You can configure up to 10 connection conditions.

1. Start your web browser.
2. Type "https://machine's IP address" in your browser's address bar (where "machine's IP address" is the machine's IP address).

For example:

https://192.168.1.2

3. If required, type the password in the **Login** field, and then click **Login**.



The default password to manage this machine's settings is located on the back of the machine and marked "**Pwd**".

4. Go to the navigation menu, and then click **Network > Security > IPsec**.



Start from , if the navigation menu is not shown on the left side of the screen.

5. Configure the settings.

| Option | Description |
|-----------------------------------|---|
| Status | Enable or disable IPsec. |
| Negotiation Mode | Select Negotiation Mode for IKE Phase 1. IKE is a protocol that is used to exchange encryption keys in order to carry out encrypted communication using IPsec. In Main mode, the processing speed is slow, but the security is high. In Aggressive mode, the processing speed is faster than Main mode, but the security is lower. |
| All Non-IPsec Traffic | Select the action to be taken for non-IPsec packets. When using Web Services, you must select Allow for All Non-IPsec Traffic . If you select Drop , Web Services cannot be used. |
| Broadcast/Multicast Bypass | Select Enabled or Disabled . |
| Protocol Bypass | Select the checkbox for the option or options you want. |
| Rules | Select the Enabled checkbox to activate the template. When you select multiple checkboxes, the lower numbered checkboxes have priority if the settings for the selected checkboxes conflict. Click on the corresponding drop-down list to select the Address Template that is used for the IPsec connection conditions. To add an Address Template , click Add Template . Click on the corresponding drop-down list to select the IPsec Template that is used for the IPsec connection conditions. To add an IPsec Template , click Add Template . |

6. Click **Submit**.

If the machine must be restarted to register the new settings, the restart confirmation screen will appear.

If there is a blank item in the template you enabled in the **Rules** table, an error message appears. Confirm your choices and click **Submit** again.



Related Information

- [Use IPsec](#)

Related Topics:

- [Access Web Based Management](#)
- [Configure Certificates for Device Security](#)

Configure an IPsec Address Template Using Web Based Management

1. Start your web browser.
2. Type "https://machine's IP address" in your browser's address bar (where "machine's IP address" is the machine's IP address).

For example:

https://192.168.1.2

3. If required, type the password in the **Login** field, and then click **Login**.



The default password to manage this machine's settings is located on the back of the machine and marked "Pwd".

4. Go to the navigation menu, and then click **Network > Security > IPsec Address Template**.



Start from , if the navigation menu is not shown on the left side of the screen.

5. Click the **Delete** button to delete an **Address Template**. When an **Address Template** is in use, it cannot be deleted.
6. Click the **Address Template** that you want to create. The **IPsec Address Template** appears.
7. Configure the settings.

| Option | Description |
|--------------------------|--|
| Template Name | Type a name for the template (up to 16 characters). |
| Local IP Address | <ul style="list-style-type: none">• IP Address Specify the IP address. Select ALL IPv4 Address, ALL IPv6 Address, ALL Link Local IPv6, or Custom from the drop-down list. If you select Custom from the drop-down list, type the IP address (IPv4 or IPv6) in the text box.• IP Address Range Type the starting and ending IP addresses for the IP address range in the text boxes. If the starting and ending IP addresses are not standardized to IPv4 or IPv6, or the ending IP address is smaller than the starting address, an error will occur.• IP Address / Prefix Specify the IP address using CIDR notation. For example: 192.168.1.1/24 Because the prefix is specified in the form of a 24-bit subnet mask (255.255.255.0) for 192.168.1.1, the addresses 192.168.1.xxx are valid. |
| Remote IP Address | <ul style="list-style-type: none">• Any If you select Any, all IP addresses are enabled.• IP Address Type the specified IP address (IPv4 or IPv6) in the text box.• IP Address Range Type the starting and ending IP addresses for the IP address range. If the starting and ending IP addresses are not standardized to IPv4 or IPv6, or the ending IP address is smaller than the starting address, an error will occur.• IP Address / Prefix Specify the IP address using CIDR notation. For example: 192.168.1.1/24 Because the prefix is specified in the form of a 24-bit subnet mask (255.255.255.0) for 192.168.1.1, the addresses 192.168.1.xxx are valid. |

8. Click **Submit**.



When you change the settings for the template currently in use, restart your machine to active the configuration.



Related Information

- [Use IPsec](#)

Related Topics:

- [Access Web Based Management](#)
-

Configure an IPsec Template Using Web Based Management

1. Start your web browser.
2. Type "https://machine's IP address" in your browser's address bar (where "machine's IP address" is the machine's IP address).

For example:

https://192.168.1.2

3. If required, type the password in the **Login** field, and then click **Login**.



The default password to manage this machine's settings is located on the back of the machine and marked "Pwd".

4. Go to the navigation menu, and then click **Network > Security > IPsec Template**.



Start from , if the navigation menu is not shown on the left side of the screen.

5. Click the **Delete** button to delete an **IPsec Template**. When an **IPsec Template** is in use, it cannot be deleted.
6. Click **IPsec Template** that you want to create. The **IPsec Template** screen appears. The configuration fields differ based on the **Use Prefixed Template** and **Internet Key Exchange (IKE)** you select.
7. In the **Template Name** field, type a name for the template (up to 16 characters).
8. If you selected **Custom** in the **Use Prefixed Template** drop-down list, select the **Internet Key Exchange (IKE)** options, and then change the settings if needed.
9. Click **Submit**.



Related Information



- [Use IPsec](#)
 - [IKEv1 Settings for an IPsec Template](#)
 - [IKEv2 Settings for an IPsec Template](#)
 - [Manual Settings for an IPsec Template](#)

Related Topics:

- [Access Web Based Management](#)
-

IKEv1 Settings for an IPsec Template

| Option | Description |
|------------------------------------|--|
| Template Name | Type a name for the template (up to 16 characters). |
| Use Prefixed Template | Select Custom , IKEv1 High Security or IKEv1 Medium Security . The setting items are different depending on the selected template. |
| Internet Key Exchange (IKE) | <p>IKE is a communication protocol that is used to exchange encryption keys in order to carry out encrypted communication using IPsec. To carry out encrypted communication for that time only, the encryption algorithm that is necessary for IPsec is determined and the encryption keys are shared. For IKE, the encryption keys are exchanged using the Diffie-Hellman key exchange method, and encrypted communication that is limited to IKE is carried out.</p> <p>If you selected Custom in Use Prefixed Template, select IKEv1.</p> |
| Authentication Type | <ul style="list-style-type: none"> • Diffie-Hellman Group This key exchange method allows secret keys to be securely exchanged over an unprotected network. The Diffie-Hellman key exchange method uses a discrete logarithm problem, not the secret key, to send and receive open information that was generated using a random number and the secret key. Select Group1, Group2, Group5, or Group14. • Encryption Select DES, 3DES, AES-CBC 128, or AES-CBC 256. • Hash Select MD5, SHA1, SHA256, SHA384 or SHA512. • SA Lifetime Specify the IKE SA lifetime. Type the time (seconds) and number of kilobytes (KByte). |

| Option | Description |
|-------------------------------|--|
| Encapsulating Security | <ul style="list-style-type: none"> • Protocol Select ESP, AH, or AH+ESP. <hr/> <p> - ESP is a protocol for carrying out encrypted communication using IPsec. ESP encrypts the payload (communicated contents) and adds additional information. The IP packet comprises the header and the encrypted payload, which follows the header. In addition to the encrypted data, the IP packet also includes information regarding the encryption method and encryption key, the authentication data, and so on.</p> <p>- AH is part of the IPsec protocol that authenticates the sender and prevents manipulation (ensures the completeness) of the data. In the IP packet, the data is inserted immediately after the header. In addition, the packets include hash values, which are calculated using an equation from the communicated contents, secret key, and so on, in order to prevent the falsification of the sender and manipulation of the data. Unlike ESP, the communicated contents are not encrypted, and the data is sent and received as plain text.</p> <hr/> <ul style="list-style-type: none"> • Encryption Select DES, 3DES, AES-CBC 128, or AES-CBC 256. • Hash Select None, MD5, SHA1, SHA256, SHA384 or SHA512. • SA Lifetime Specify the IKE SA lifetime. Type the time (seconds) and number of kilobytes (KByte). • Encapsulation Mode Select Transport or Tunnel. • Remote Router IP-Address Type the IP address (IPv4 or IPv6) of the remote router. Enter this information only when the Tunnel mode is selected. <hr/> <p> SA (Security Association) is an encrypted communication method using IPsec or IPv6 that exchanges and shares information, such as the encryption method and encryption key, in order to establish a secure communication channel before communication begins. SA may also refer to a virtual encrypted communication channel that has been established. The SA used for IPsec establishes the encryption method, exchanges the keys, and carries out mutual authentication according to the IKE (Internet Key Exchange) standard procedure. In addition, the SA is updated periodically.</p> |
| Perfect Forward Secrecy (PFS) | <p>PFS does not derive keys from previous keys that were used to encrypt messages. In addition, if a key that is used to encrypt a message was derived from a parent key, that parent key is not used to derive other keys. Therefore, even if a key is compromised, the damage will be limited only to the messages that were encrypted using that key.</p> <p>Select Enabled or Disabled.</p> |
| Authentication Method | <p>Select the authentication method. Select Pre-Shared Key or Certificates.</p> |



| Option | Description |
|-----------------------|--|
| Pre-Shared Key | <p>When encrypting communication, the encryption key is exchanged and shared beforehand using another channel.</p> <p>If you selected Pre-Shared Key for the Authentication Method, type the Pre-Shared Key (up to 32 characters).</p> <ul style="list-style-type: none"> • Local/ID Type/ID Select the sender's ID type, and then type the ID. Select IPv4 Address, IPv6 Address, FQDN, E-mail Address, or Certificate for the type. If you select Certificate, type the common name of the certificate in the ID field. • Remote/ID Type/ID Select the recipient's ID type, and then type the ID. Select IPv4 Address, IPv6 Address, FQDN, E-mail Address, or Certificate for the type. If you select Certificate, type the common name of the certificate in the ID field. |
| Certificate | <p>If you selected Certificates for Authentication Method, select the certificate.</p> <hr/> <p> You can select only the certificates that were created using the Certificate page of Web Based Management's Security configuration screen.</p> <hr/> |

 **Related Information**

- [Configure an IPsec Template Using Web Based Management](#)

IKEv2 Settings for an IPsec Template

| Option | Description |
|------------------------------------|--|
| Template Name | Type a name for the template (up to 16 characters). |
| Use Prefixed Template | Select Custom , IKEv2 High Security , or IKEv2 Medium Security . The setting items are different depending on the selected template. |
| Internet Key Exchange (IKE) | <p>IKE is a communication protocol that is used to exchange encryption keys in order to carry out encrypted communication using IPsec. To carry out encrypted communication for that time only, the encryption algorithm that is necessary for IPsec is determined and the encryption keys are shared. For IKE, the encryption keys are exchanged using the Diffie-Hellman key exchange method, and encrypted communication that is limited to IKE is carried out.</p> <p>If you selected Custom in Use Prefixed Template, select IKEv2.</p> |
| Authentication Type | <ul style="list-style-type: none"> • Diffie-Hellman Group This key exchange method allows secret keys to be securely exchanged over an unprotected network. The Diffie-Hellman key exchange method uses a discrete logarithm problem, not the secret key, to send and receive open information that was generated using a random number and the secret key. Select Group1, Group2, Group5, or Group14. • Encryption Select DES, 3DES, AES-CBC 128, or AES-CBC 256. • Hash Select MD5, SHA1, SHA256, SHA384 or SHA512. • SA Lifetime Specify the IKE SA lifetime. Type the time (seconds) and number of kilobytes (KByte). |



| Option | Description |
|--------------------------------------|--|
| Encapsulating Security | <ul style="list-style-type: none"> • Protocol Select ESP. <hr/> <p> ESP is a protocol for carrying out encrypted communication using IPsec. ESP encrypts the payload (communicated contents) and adds additional information. The IP packet comprises the header and the encrypted payload, which follows the header. In addition to the encrypted data, the IP packet also includes information regarding the encryption method and encryption key, the authentication data, and so on.</p> <hr/> <ul style="list-style-type: none"> • Encryption Select DES, 3DES, AES-CBC 128, or AES-CBC 256. • Hash Select MD5, SHA1, SHA256, SHA384, or SHA512. • SA Lifetime Specify the IKE SA lifetime. Type the time (seconds) and number of kilobytes (KByte). • Encapsulation Mode Select Transport or Tunnel. • Remote Router IP-Address Type the IP address (IPv4 or IPv6) of the remote router. Enter this information only when the Tunnel mode is selected. <hr/> <p> SA (Security Association) is an encrypted communication method using IPsec or IPv6 that exchanges and shares information, such as the encryption method and encryption key, in order to establish a secure communication channel before communication begins. SA may also refer to a virtual encrypted communication channel that has been established. The SA used for IPsec establishes the encryption method, exchanges the keys, and carries out mutual authentication according to the IKE (Internet Key Exchange) standard procedure. In addition, the SA is updated periodically.</p> |
| Perfect Forward Secrecy (PFS) | <p>PFS does not derive keys from previous keys that were used to encrypt messages. In addition, if a key that is used to encrypt a message was derived from a parent key, that parent key is not used to derive other keys. Therefore, even if a key is compromised, the damage will be limited only to the messages that were encrypted using that key.</p> <p>Select Enabled or Disabled.</p> |
| Authentication Method | <p>Select the authentication method. Select Pre-Shared Key, Certificates, EAP - MD5, or EAP - MS-CHAPv2.</p> <hr/> <p> EAP is an authentication protocol that is an extension of PPP. By using EAP with IEEE802.1x, a different key is used for user authentication during each session.</p> <p>The following settings are necessary only when EAP - MD5 or EAP - MS-CHAPv2 is selected in Authentication Method:</p> <ul style="list-style-type: none"> • Mode Select Server-Mode or Client-Mode. • Certificate Select the certificate. • User Name Type the user name (up to 32 characters). • Password Type the password (up to 32 characters). The password must be entered two times for confirmation. |



| Option | Description |
|-----------------------|--|
| Pre-Shared Key | <p>When encrypting communication, the encryption key is exchanged and shared beforehand using another channel.</p> <p>If you selected Pre-Shared Key for the Authentication Method, type the Pre-Shared Key (up to 32 characters).</p> <ul style="list-style-type: none"> Local/ID Type/ID Select the sender's ID type, and then type the ID. Select IPv4 Address, IPv6 Address, FQDN, E-mail Address, or Certificate for the type. If you select Certificate, type the common name of the certificate in the ID field. Remote/ID Type/ID Select the recipient's ID type, and then type the ID. Select IPv4 Address, IPv6 Address, FQDN, E-mail Address, or Certificate for the type. If you select Certificate, type the common name of the certificate in the ID field. |
| Certificate | <p>If you selected Certificates for Authentication Method, select the certificate.</p> <hr/> <p> You can select only the certificates that were created using the Certificate page of Web Based Management's Security configuration screen.</p> <hr/> |

Related Information

- [Configure an IPsec Template Using Web Based Management](#)

Manual Settings for an IPsec Template

| Option | Description |
|-------------------------------------|---|
| Template Name | Type a name for the template (up to 16 characters). |
| Use Prefixed Template | Select Custom . |
| Internet Key Exchange (IKE) | <p>IKE is a communication protocol that is used to exchange encryption keys in order to carry out encrypted communication using IPsec. To carry out encrypted communication for that time only, the encryption algorithm that is necessary for IPsec is determined and the encryption keys are shared. For IKE, the encryption keys are exchanged using the Diffie-Hellman key exchange method, and encrypted communication that is limited to IKE is carried out.</p> <p>Select Manual.</p> |
| Authentication Key (ESP, AH) | <p>Type the In/Out values.</p> <p>These settings are necessary when Custom is selected for Use Prefixed Template, Manual is selected for Internet Key Exchange (IKE), and a setting other than None is selected for Hash for Encapsulating Security section.</p> <hr/> <p> The number of characters you can set differs depending on the setting you chose for Hash in the Encapsulating Security section. If the length of the specified authentication key is different than the selected hash algorithm, an error will occur.</p> <ul style="list-style-type: none"> • MD5: 128 bits (16 bytes) • SHA1: 160 bits (20 bytes) • SHA256: 256 bits (32 bytes) • SHA384: 384 bits (48 bytes) • SHA512: 512 bits (64 bytes) <p>When you specify the key in ASCII Code, enclose the characters in double quotation marks ("").</p> <hr/> |
| Code key (ESP) | <p>Type the In/Out values.</p> <p>These settings are necessary when Custom is selected in Use Prefixed Template, Manual is selected in Internet Key Exchange (IKE), and ESP is selected in Protocol in Encapsulating Security.</p> <hr/> <p> The number of characters you can set differs depending on the setting you chose for Encryption in the Encapsulating Security section. If the length of the specified code key is different than the selected encryption algorithm, an error will occur.</p> <ul style="list-style-type: none"> • DES: 64 bits (8 bytes) • 3DES: 192 bits (24 bytes) • AES-CBC 128: 128 bits (16 bytes) • AES-CBC 256: 256 bits (32 bytes) <p>When you specify the key in ASCII Code, enclose the characters in double quotation marks ("").</p> <hr/> |
| SPI | <p>These parameters are used to identify security information. Generally, a host has multiple Security Associations (SAs) for several types of IPsec communication. Therefore, it is necessary to identify the applicable SA when an IPsec packet is received. The SPI parameter, which identifies the SA, is included in the Authentication Header (AH) and Encapsulating Security Payload (ESP) header.</p> <p>These settings are necessary when Custom is selected for Use Prefixed Template, and Manual is selected for Internet Key Exchange (IKE). Enter the In/Out values. (3-10 characters)</p> |

| Option | Description |
|------------------------|--|
| Encapsulating Security | <ul style="list-style-type: none"> <li data-bbox="608 215 863 271">• Protocol Select ESP or AH. <hr/> <ul style="list-style-type: none"> <li data-bbox="635 304 1471 524">  <ul style="list-style-type: none"> <li data-bbox="687 315 1471 524">• ESP is a protocol for carrying out encrypted communication using IPsec. ESP encrypts the payload (communicated contents) and adds additional information. The IP packet comprises the header and the encrypted payload, which follows the header. In addition to the encrypted data, the IP packet also includes information regarding the encryption method and encryption key, the authentication data, and so on. <li data-bbox="687 535 1471 804"> <ul style="list-style-type: none"> <li data-bbox="687 535 1471 804">• AH is part of the IPsec protocol that authenticates the sender and prevents manipulation of the data (ensures the completeness of the data). In the IP packet, the data is inserted immediately after the header. In addition, the packets include hash values, which are calculated using an equation from the communicated contents, secret key, and so on, in order to prevent the falsification of the sender and manipulation of the data. Unlike ESP, the communicated contents are not encrypted, and the data is sent and received as plain text. <hr/> <ul style="list-style-type: none"> <li data-bbox="608 831 1259 887">• Encryption Select DES, 3DES, AES-CBC 128, or AES-CBC 256. <li data-bbox="608 891 1198 981">• Hash Select None, MD5, SHA1, SHA256, SHA384, or SHA512. None can be selected only when ESP is selected in Protocol. <li data-bbox="608 985 1299 1072">• SA Lifetime Specify the IKE SA lifetime. Type the time (seconds) and number of kilobytes (KByte). <li data-bbox="608 1077 975 1133">• Encapsulation Mode Select Transport or Tunnel. <li data-bbox="608 1137 1394 1225">• Remote Router IP-Address Type the IP address (IPv4 or IPv6) of the remote router. Enter this information only when the Tunnel mode is selected. <hr/> <ul style="list-style-type: none"> <li data-bbox="635 1258 1471 1541">  <p data-bbox="687 1270 1471 1541">SA (Security Association) is an encrypted communication method using IPsec or IPv6 that exchanges and shares information, such as the encryption method and encryption key, in order to establish a secure communication channel before communication begins. SA may also refer to a virtual encrypted communication channel that has been established. The SA used for IPsec establishes the encryption method, exchanges the keys, and carries out mutual authentication according to the IKE (Internet Key Exchange) standard procedure. In addition, the SA is updated periodically.</p> |

Related Information

- [Configure an IPsec Template Using Web Based Management](#)

Use IEEE 802.1x Authentication for a Wired or a Wireless Network

- [What Is IEEE 802.1x Authentication?](#)
- [Configure IEEE 802.1x Authentication for a Wired or a Wireless Network Using Web Based Management \(Web Browser\)](#)
- [IEEE 802.1x Authentication Methods](#)

What Is IEEE 802.1x Authentication?

IEEE 802.1x is an IEEE standard for wired and wireless networks that limits access from unauthorized network devices. Your Brother machine (supplicant) sends an authentication request to a RADIUS server (Authentication server) through your access point or HUB. After your request has been verified by the RADIUS server, your machine can access the network.



Related Information

- [Use IEEE 802.1x Authentication for a Wired or a Wireless Network](#)
-

Configure IEEE 802.1x Authentication for a Wired or a Wireless Network Using Web Based Management (Web Browser)

- If you configure your machine using EAP-TLS authentication, you must install the client certificate issued by a CA before you start configuration. Contact your network administrator about the client certificate. If you have installed more than one certificate, we recommend writing down the certificate name you want to use.
- Before you verify the server certificate, you must import the CA certificate issued by the CA that signed the server certificate. Contact your network administrator or your Internet Service Provider (ISP) to confirm whether a CA certificate import is necessary.

 You can also configure IEEE 802.1x authentication using Wireless setup wizard from the control panel (Wireless network).

1. Start your web browser.
2. Type "https://machine's IP address" in your browser's address bar (where "machine's IP address" is the machine's IP address).

For example:

https://192.168.1.2

 If you are using a Domain Name System or enable a NetBIOS name, you can type another name, such as "SharedPrinter" instead of the IP address.

For example:

https://SharedPrinter

If you enable a NetBIOS name, you can also use the node name.

For example:



https://brn123456abcdef

The NetBIOS name can be found in the Network Configuration Report.

3. If required, type the password in the **Login** field, and then click **Login**.

 The default password to manage this machine's settings is located on the back of the machine and marked "Pwd".

4. Go to the navigation menu, and then click **Network**.

 Start from , if the navigation menu is not shown on the left side of the screen.

5. Do one of the following:
 - For the wired network
Click **Wired** > **Wired 802.1x Authentication**.
 - For the wireless network
Click **Wireless** > **Wireless (Enterprise)**.
6. Configure the IEEE 802.1x authentication settings.

 To enable IEEE 802.1x authentication for wired networks, select **Enabled** for **Wired 802.1x status** on the **Wired 802.1x Authentication** page.

- If you are using **EAP-TLS** authentication, you must select the client certificate installed (shown with certificate name) for verification from the **Client Certificate** drop-down list.
- If you select **EAP-FAST**, **PEAP**, **EAP-TTLS**, or **EAP-TLS** authentication, select the verification method from the **Server Certificate Verification** drop-down list. Verify the server certificate using the CA certificate, imported to the machine in advance, issued by the CA that signed the server certificate.

Select one of the following verification methods from the **Server Certificate Verification** drop-down list:

| Option | Description |
|----------------------------|--|
| No Verification | The server certificate can always be trusted. The verification is not performed. |
| CA Cert. | The verification method to check the CA reliability of the server certificate, using the CA certificate issued by the CA that signed the server certificate. |
| CA Cert. + ServerID | The verification method to check the common name ¹ value of the server certificate, in addition to the CA reliability of the server certificate. |

7. When finished with configuration, click **Submit**.

For wired networks: After configuring, connect your machine to the IEEE 802.1x supported network. After a few minutes, print the Network Configuration Report to check the **<Wired IEEE 802.1x>** status.

| Option | Description |
|----------------|--|
| Success | The wired IEEE 802.1x function is enabled and the authentication was successful. |
| Failed | The wired IEEE 802.1x function is enabled; however, the authentication failed. |
| Off | The wired IEEE 802.1x function is not available. |

Related Information

- [Use IEEE 802.1x Authentication for a Wired or a Wireless Network](#)

Related Topics:

- [Print the Network Configuration Report](#)
- [Print the WLAN Report](#)
- [Access Web Based Management](#)
- [Configure Certificates for Device Security](#)
- [Supported Security Certificate Features](#)

¹ The common name verification compares the common name of the server certificate to the character string configured for the **Server ID**. Before you use this method, contact your system administrator about the server certificate's common name and then configure **Server ID**.

IEEE 802.1x Authentication Methods

EAP-FAST

Extensible Authentication Protocol-Flexible Authentication via Secured Tunneling (EAP-FAST) has been developed by Cisco Systems, Inc., which uses a user ID and password for authentication, and symmetric key algorithms to achieve a tunneled authentication process.

The Brother machine supports the following inner authentication methods:

- EAP-FAST/NONE
- EAP-FAST/MS-CHAPv2
- EAP-FAST/GTC

EAP-MD5 (Wired network)

Extensible Authentication Protocol-Message Digest Algorithm 5 (EAP-MD5) uses a user ID and password for challenge-response authentication.

PEAP

Protected Extensible Authentication Protocol (PEAP) is a version of EAP method developed by Cisco Systems, Inc., Microsoft Corporation and RSA Security. PEAP creates an encrypted Secure Sockets Layer (SSL)/Transport Layer Security (TLS) tunnel between a client and an authentication server, for sending a user ID and password. PEAP provides mutual authentication between the server and the client.

The Brother machine supports the following inner authentications:

- PEAP/MS-CHAPv2
- PEAP/GTC

EAP-TTLS

Extensible Authentication Protocol-Tunneled Transport Layer Security (EAP-TTLS) has been developed by Funk Software and Certicom. EAP-TTLS creates a similar encrypted SSL tunnel to PEAP, between a client and an authentication server, for sending a user ID and password. EAP-TTLS provides mutual authentication between the server and the client.

The Brother machine supports the following inner authentications:

- EAP-TTLS/CHAP
- EAP-TTLS/MS-CHAP
- EAP-TTLS/MS-CHAPv2
- EAP-TTLS/PAP

EAP-TLS

Extensible Authentication Protocol-Transport Layer Security (EAP-TLS) requires digital certificate authentication both at a client and an authentication server.



Related Information

- [Use IEEE 802.1x Authentication for a Wired or a Wireless Network](#)
-

Send an Email Securely

- [Configure Email Sending Using Web Based Management](#)
- [Send an Email with User Authentication](#)
- [Send an Email Securely Using SSL/TLS](#)

Configure Email Sending Using Web Based Management

We recommend using Web Based Management to configure secured email sending with user authentication, or email sending using SSL/TLS.

1. Start your web browser.
2. Type "https://machine's IP address" in your browser's address bar (where "machine's IP address" is the machine's IP address).
For example:
https://192.168.1.2
3. If required, type the password in the **Login** field, and then click **Login**.



The default password to manage this machine's settings is located on the back of the machine and marked "Pwd".

4. Go to the navigation menu, and then click **Network > Network > Protocol**.



Start from , if the navigation menu is not shown on the left side of the screen.

5. In the **SMTP Client** field, click **Advanced Settings** and make sure the status of **SMTP Client** is **Enabled**.
6. Configure the **SMTP Client** settings.
 - Confirm that the email settings are correct after configuration by sending a test email.
 - If you do not know the SMTP server settings, contact your network administrator or Internet Service Provider (ISP).
7. When finished, click **Submit**.
The **Test Send E-mail Configuration** dialog box appears.
8. Follow the instructions in the dialog box to test the current settings.



Related Information

- [Send an Email Securely](#)

Related Topics:

- [Access Web Based Management](#)
-

Send an Email with User Authentication

Your machine supports the SMTP-AUTH method to send email via an email server that requires user authentication. This method prevents unauthorized users from accessing the email server.

You can use the SMTP-AUTH method for email notification and email reports (available for certain models).



We recommend using Web Based Management to configure the SMTP authentication.

Email Server Settings

You must configure your machine's SMTP authentication method to match the method used by your email server. For details about your email server settings, contact your network administrator or Internet Service Provider (ISP).



To enable SMTP server authentication: in the Web Based Management **SMTP Client** screen, under **Server Authentication Method**, you must select **SMTP-AUTH**.



Related Information

- [Send an Email Securely](#)
-

Send an Email Securely Using SSL/TLS

Your machine supports SSL/TLS communication methods. To use an email server that is using SSL/TLS communication, you must configure the following settings.



We recommend using Web Based Management to configure SSL/TLS.

Verify Server Certificate

Under **SSL/TLS**, if you choose **SSL** or **TLS**, the **Verify Server Certificate** checkbox will be selected automatically.



- Before you verify the server certificate, you must import the CA certificate issued by the CA that signed the server certificate. Contact your network administrator or your Internet Service Provider (ISP) to confirm if importing a CA certificate is necessary.
- If you do not need to verify the server certificate, clear the **Verify Server Certificate** checkbox.

Port Number

If you select **SSL**, or **TLS**, the **Port** value will be changed to match the protocol. To change the port number manually, type the port number after you select **SSL/TLS** settings.

You must configure your machine's communication method to match the method used by your email server. For details about your email server settings, contact your network administrator or your ISP.

In most cases, the secured webmail services require the following settings:

| | | |
|------|-------------------------------------|------------------|
| SMTP | Port | 25 |
| | Server Authentication Method | SMTP-AUTH |
| | SSL/TLS | TLS |



Related Information

- [Send an Email Securely](#)

Related Topics:

- [Configure Certificates for Device Security](#)
 - [Use SSL/TLS](#)
-

Mobile Connect

- [Brother Artspira](#)
- [AirPrint](#)

Brother Artspira

- [Brother Artspira Overview](#)
- [Connect Your Mobile Device to Your Machine Using Brother Artspira](#)
- [Print a Design Using Brother Artspira](#)
- [Print an Image Saved On Your Mobile Device Using Brother Artspira](#)

Brother Artspira Overview

Use Brother Artspira to print from your mobile device.

- For Android™ devices:
Brother Artspira allows you to use your Brother machine's features directly from your Android™ device.
Download and install Brother Artspira from Google Play™.
 - For all iOS supported devices including iPhone:
Brother Artspira allows you to use your Brother machine's features directly from your iOS device.
Download and install Brother Artspira from the App Store.
1. Visit <https://s.brother/snjumq3332/> to download and install Brother Artspira to your mobile device.

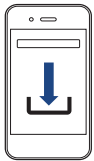

Related Information

- [Mobile Connect](#)

Connect Your Mobile Device to Your Machine Using Brother Artspira

1. Tap the Artspira icon on your mobile device to open the app, and then log in.
2. Tap  in the upper right corner of the Artspira home screen.
3. Tap **Register** under **Creative Printer**.
4. Tap **Wireless LAN Guidance** and follow the on-screen instructions to set up your machine's wireless network connection.
When the connection succeeds, Artspira will search for connectible printers.
5. Select your machine's model name from the list that appears. When your mobile device and machine are connected, a check mark appears next to the printer in the list.



Related Information

- [Mobile Connect](#)
-

Print a Design Using Brother Artspira

1. Make sure your machine is turned on.
Make sure you have loaded the correct paper in the paper tray and changed the paper settings for the paper tray you are using.
2. Tap the Artspira icon on your mobile device to open the app, and then log in.
3. Select a printing design from **Home** screen.
4. Tap **Create** and edit the data if necessary, and then tap **Done**.



To save the edited data, tap **Save**. Data saved on the server can be retrieved by tapping  **(My Creations)**.

5. Make sure your Brother Sublimation Printer is selected. If your machine is not selected, tap **Printer**.
A list of available machines appears.
6. Tap your machine's name in the list.
7. Tap **Print settings** to set the print settings.
8. Tap **Print**.



Printed images will automatically be mirrored, or reversed horizontally from left to right. You can change the settings on the **Print settings** menu.



Related Information

- [Brother Artspira](#)
-

Print an Image Saved On Your Mobile Device Using Brother Artspira

1. Make sure your machine is turned on.
Make sure you have loaded the correct paper in the paper tray and changed the paper settings for the paper tray you are using.
2. Tap the Artspira icon on your mobile device to open the app, and then log in.
3. Tap  **(New)** at the bottom of the Home screen.
4. Tap the **Printing** tab and select the editing menu.
5. Edit the data if necessary, and then tap **Done**.



To save the edited data, tap **Save**. Data saved on the server can be retrieved by tapping  **(My Creations)**.

6. Make sure your machine is selected. If your Brother Sublimation Printer is not selected, tap **Printer**.
A list of available machines appears.
7. Tap your machine's name in the list.
8. Tap **Print settings** to set the print settings.
9. Tap **Print**.



Printed images will automatically be mirrored, or reversed horizontally from left to right. You can change the settings on the **Print settings** menu.



Related Information

- [Brother Artspira](#)
-

AirPrint

- [AirPrint Overview](#)
- [Before Using AirPrint \(macOS\)](#)
- [Print Using AirPrint](#)

AirPrint Overview

AirPrint is a printing solution for Apple operating systems that allows you to wirelessly print photos, email, web pages and documents from your iPad, iPhone, iPod touch and Mac computer without the need to install a driver.

For more information, visit Apple's website.

Use of the Works with Apple badge means that an accessory has been designed to work specifically with the technology identified in the badge and has been certified by the developer to meet Apple performance standards.



Related Information

- [AirPrint](#)
-

Before Using AirPrint (macOS)

Before printing using macOS, add your machine to the printer list on your Mac computer.

1. Do one of the following:
 - macOS v13
Select **System Settings** from the Apple menu.
 - macOS v12 and macOS v11
Select **System Preferences** from the Apple menu.
2. Select **Printers & Scanners**.
3. Do one of the following:
 - macOS v13
Click **Add Printer, Scanner, or Fax....**
 - macOS v12 and macOS v11
Click the + icon below the Printers pane on the left.
The **Add Printer** screen appears.
4. Do one of the following:
 - macOS v13 and macOS v12
Select your machine, and then select your model's name from the **Use** pop-up menu.
 - macOS v11
Select your machine, and then select **AirPrint** from the **Use** pop-up menu.
5. Click **Add**.



Related Information



- [AirPrint](#)

Print Using AirPrint

- [Print from iPad, iPhone, or iPod touch](#)
- [Print Using AirPrint \(macOS\)](#)

Print from iPad, iPhone, or iPod touch

The procedure used to print may vary by application. Safari is used in the example below.

1. Make sure your machine is turned on.
Make sure you have loaded the correct paper in the paper tray and change the paper settings for the paper tray on your machine.
2. Use Safari to open the page that you want to print.
3. Tap  or .
4. Tap **Print**.
5. Make sure your machine is selected.
6. If a different machine (or no printer) is selected, tap **Printer**.
A list of available machines appears.
7. Tap your machine's name in the list.
8. Select the options you want, such as the number of pages to print and 2-sided printing (if supported by your machine).
9. Tap **Print**.

Related Information

- [Print Using AirPrint](#)

Print Using AirPrint (macOS)

The procedure used to print may vary by application. Safari is used in the example below. Before printing, make sure your machine is in the printer list on your Mac computer.

1. Make sure your machine is turned on.
2. Load the paper in the paper tray and change the paper tray settings on your machine.
3. On your Mac computer, use Safari to open the page that you want to print.
4. Click the **File** menu, and then select **Print**.
5. Make sure your machine is selected. If a different machine (or no printer) is selected, click the **Printer** pop-up menu, and then select your machine.
6. Select the desired options, such as the number of pages to print and 2-sided printing (if supported by your machine).
7. Click **Print**.



Related Information

- [Print Using AirPrint](#)

Related Topics:

- [Before Using AirPrint \(macOS\)](#)
-

Troubleshooting

If you think there is a problem with your machine, first check each of the items below, then try to identify the problem, and follow our troubleshooting tips.

You can correct most problems yourself. If you need additional help, visit <https://s.brother/cf2ab/> for the latest **FAQs & Troubleshooting** tips:

First, check the following:

- The machine's power cord is connected correctly and the machine's power is on.
- All of the machine's protective parts have been removed.
- The ink cartridges are installed correctly.
- The Top Cover and the Jam Clear Cover are fully closed.
- Paper is inserted correctly in the paper tray.
- The interface cables are securely connected to the machine and the computer, or the wireless connection is set up on both the machine and your computer.
- (For network models) The access point (for wireless), router, or hub is turned on and its link indicator is blinking.
- The machine's LCD is displaying messages.

If you did not solve the problem with the checks, identify the problem and then see *Related Information*.

CAUTION

- Black Sublimation Ink may cause an allergic reaction.
- Wear a protective gloves when there is a possibility of touching the ink, such as when replacing the ink cartridges or clearing paper jams.
- If the ink accidentally gets on your skin, wash immediately with soap and cold water. If skin irritation or rash occurs, seek medical attention immediately.

Related Information

- [Error and Maintenance Messages](#)
- [Printer Jam or Paper Jam](#)
- [If You Are Having Difficulty with Your Machine](#)
- [Check the Machine Information](#)
- [Reset Your Machine](#)

Related Topics:

- [Paper Handling and Printing Problems](#)
 - [Other Problems](#)
 - [Network Problems](#)
 - [AirPrint Problems](#)
 - [Artspira Problems](#)
-

Error and Maintenance Messages

As with any sophisticated office product, errors may occur and supply items may have to be replaced. If this happens, your machine identifies the error or required routine maintenance and shows the appropriate message. The most common error and maintenance messages are shown in the table.

You can correct most errors and perform routine maintenance yourself. If you need more tips, go to your model's **FAQs & Troubleshooting** page at <https://s.brother/cf2ab/>.



Related Information references are at the bottom of this page.

| Error Message | Cause | Action |
|--|---|--|
| Cannot Clean XX Cannot Initialize XX Cannot Print XX | The machine has a mechanical problem. -OR- A foreign object, such as a paper clip or a piece of ripped paper, is in the machine. | Open the top cover and remove any foreign objects and paper scraps from inside the machine. If the error message continues, disconnect the machine from the power for several minutes, and then reconnect it. <i>See Related Information: Paper is Jammed Inside and in the Front of the Machine (Jam Inside/ Front).</i> |
| Cannot Detect | An ink cartridge is not installed correctly. | Take out the new ink cartridge and reinstall it slowly and firmly until it locks into place. <i>See Related Information: Replace the Ink Cartridges.</i> |
| | The wrong Brother model ink cartridge was installed. | Check the model numbers of the ink cartridges and install the correct ink cartridges. |
| Connection Error | Other devices are trying to connect to the Wi-Fi Direct network at the same time. | Make sure there are no other devices trying to connect to the Wi-Fi Direct network, and then try to configure the Wi-Fi Direct settings again. |
| Connection Failed | The Brother machine and your mobile device cannot communicate during the Wi-Fi Direct network configuration. | <ul style="list-style-type: none"> • Move the mobile device closer to your Brother machine. • Move your Brother machine and the mobile device to an obstruction-free area. • If you are using the PIN Method of WPS, make sure you have entered the correct PIN. |
| Cover is Open. | The top cover is not locked in the closed position. | Lift the top cover and then close it again. Make sure the interface cable (if used) has been guided correctly through the cable channel and out the back of the machine. |
| | The ink cartridge cover is not locked in the closed position. | Firmly close the ink cartridge cover until it locks into place. |
| Data Remaining in Memory | Print data is left in the machine's memory. | Press . The machine will cancel the job and clear it from the memory. Try to print again. |
| High Temperature | The room temperature is too high. | After cooling the room, allow the machine to cool down to room temperature. Try again when the machine has cooled down. |

| Error Message | Cause | Action |
|---|---|---|
| Ink Absorber NearFull | The ink absorber box is nearly full. | The ink absorber box must be replaced soon. Call Brother Customer Service or a Brother Authorized Service Center to have your machine serviced. The ink absorber box absorbs the small amount of ink emitted during print head cleaning. |
| Ink Absorber Pad Full | The ink absorber box is full. These components are periodic maintenance items that may require replacement after a period of time to ensure optimum performance from your Brother machine. Because these components are periodic maintenance items, the replacement is not covered under the warranty. The need to replace these items and the time period before replacement is dependent on the number of purges and flushes required to clean the ink system. These boxes acquire amounts of ink during the different purging and flushing operations. The number of times a machine purges and flushes for cleaning varies depending on different situations. For example, frequently powering the machine on and off will cause numerous cleaning cycles since the machine automatically cleans upon power up. | The ink absorber box must be replaced. Call Brother Customer Service or a Brother Authorized Service Center to have your machine serviced. |
| Ink Low | The ink level is low. | Prepare a new ink cartridge. You can continue printing until the touchscreen displays <i>Replace Ink</i> . <i>See Related Information: Replace the Ink Cartridges.</i> |
| Jam Front Repeat Jam Front | The paper is jammed in the machine. | Gently remove the jammed paper. <i>See Related Information: Paper is Jammed in the Front of the Machine (Jam Front).</i> Make sure the paper guides are set to the correct paper size. DO NOT extend the paper tray when you load A5 or smaller size paper. |
| Jam Inside/Front Repeat Jam Inside/ Front | The paper is jammed in the machine. More than one sheet of paper was placed in the manual feed slot. -OR- Another sheet of paper was placed in the manual feed slot before the touchscreen displayed <i>Where to Place the Paper</i> . <i>Paper.</i> | Gently remove the jammed paper. <i>See Related Information: Paper is Jammed Inside and in the Front of the Machine (Jam Inside/ Front).</i> Make sure the paper guides are set to the correct paper size. DO NOT extend the paper tray when you load A5 or smaller size paper. Do not put more than one sheet of paper in the manual feed slot at any one time. Wait until the touchscreen displays <i>Where to Place the Paper</i> before you feed the next sheet of paper in the manual feed slot. Gently remove the jammed paper. <i>See Related Information: Paper is Jammed Inside and in the Front of the Machine (Jam Inside/ Front).</i> |

| Error Message | Cause | Action |
|-------------------------------|--|--|
| Jam Rear | The paper is jammed in the machine. | Gently remove the jammed paper. See <i>Related Information: Paper is Jammed in the Back of the Machine (Jam Rear)</i> . Make sure the paper guides are set to the correct paper size. DO NOT extend the paper tray when you load A5 or smaller size paper. |
| | Paper dust has accumulated on the surface of the paper pick-up rollers. | Clean the paper pick-up rollers. See <i>Related Information: Clean the Paper Pick-up Rollers</i> . |
| Low Temperature | The room temperature is too low. | After warming the room, allow the machine to warm up to room temperature. Try again when the machine has warmed up. |
| No Device No device found. | When configuring the Wi-Fi Direct network, the Brother machine cannot find your mobile device. | <ul style="list-style-type: none"> • Make sure your machine and mobile device are in the Wi-Fi Direct mode. • Move the mobile device closer to your Brother machine. • Move your Brother machine and the mobile device to an obstruction-free area. • If you are manually configuring the Wi-Fi Direct network, make sure you have entered the correct password. • If your mobile device has a configuration page for how to obtain an IP address, make sure the IP address of your mobile device has been configured via DHCP. |
| No Ink Cartridge | An ink cartridge is not installed correctly. | Remove the ink cartridge and re-install it slowly and firmly until it locks into place. See <i>Related Information: Replace the Ink Cartridges</i> . |
| No Paper Fed | The machine is out of paper or paper is not correctly loaded in the paper tray. | Do one of the following: <ul style="list-style-type: none"> • Refill the paper tray, and then follow the LCD instructions. • Remove and reload the paper, and then follow the LCD instructions. See <i>Related Information: Load Paper</i> . |
| | The paper was not inserted in the center position of the manual feed slot. | Remove the paper and reinsert it in the center of the manual feed slot, and then follow the LCD instructions. See <i>Related Information: Load Paper in the Manual Feed Slot</i> . |
| | The paper in the manual feed slot does not stay straight when fed. | Using both hands, adjust the manual feed slot paper guides to make sure there is no gap between them and the paper, and then press <code>Black Start</code> or <code>Color Start</code> . See <i>Related Information: Load Paper in the Manual Feed Slot</i> . |
| | The Jam Clear Cover is not closed correctly. | Make sure the Jam Clear Cover is closed evenly at both ends. See <i>Related Information: Printer Jam or Paper Jam</i> . |
| | Paper dust has accumulated on the surface of the paper pick-up rollers. | Clean the paper pick-up rollers. See <i>Related Information: Clean the Paper Pick-up Rollers</i> . |

| Error Message | Cause | Action |
|---|--|---|
| Paper Size Mismatch | <p>The paper size setting does not match the size of paper in the tray.</p> <p>-OR-</p> <p>You did not set the paper guides in the tray to the indicators for the paper size you are using.</p> | <ol style="list-style-type: none"> 1. Check that the paper size you selected on the machine's display matches the size of the paper in the tray. <i>See Related Information: Change the Paper Size.</i> 2. Make sure you loaded the paper in the correct orientation and set the paper guides at the indicators for your paper size. <i>See Related Information: Load Paper.</i> 3. After you have checked the paper size and the paper orientation, follow the LCD instructions. <p>If you are printing from your computer, make sure the paper size you selected in the printer driver or in the application you use to print matches the size of paper in the tray. <i>See Related Information: Print Settings (Windows).</i></p> |
| Paper Tray not detected | The paper tray is not completely inserted. | Slowly push the paper tray completely into the machine. |
| | Paper or a foreign object has prevented the paper tray from being inserted correctly. | Pull the paper tray out of the machine, and remove the jammed paper or foreign object. If you cannot find or remove the jammed paper, see <i>Related Information: Printer Jam or Paper Jam.</i> |
| Repetitive No Paper Fed | Paper dust has accumulated on the surface of the paper pick-up rollers. | Clean the paper pick-up rollers. <i>See Related Information: Clean the Paper Pick-up Rollers.</i> |
| Replace Ink | One or more of the ink cartridges have reached the end of their lives. The machine will stop all print operations. | Replace the ink cartridges. <i>See Related Information: Replace the Ink Cartridges.</i> |
| The maximum number of devices are already connected using Wi-Fi Direct. | The maximum number of mobile devices are already connected to the Wi-Fi Direct network when the Brother machine is the Group Owner. | After the current connection between your Brother machine and another mobile device has shut down, try to configure the Wi-Fi Direct settings again. You can confirm the connection status by printing the Network Configuration Report. <i>See Related Information: Print the Network Configuration Report.</i> |
| Touchscreen Init. Failed | The touchscreen was pressed before the power on initialization was completed. | Make sure nothing is touching or resting on the touchscreen, especially when plugging the machine in. |
| | Debris may be stuck between the lower part of the touchscreen and its frame. | Insert a piece of stiff paper between the lower part of the touchscreen and its frame and slide it back and forth to push out the debris. |
| Tray Settings | This message is displayed when the setting to confirm the paper size is enabled. | To not display this confirmation message, change the setting to Off. <i>See Related Information: Change the Check Paper Setting.</i> |

| Error Message | Cause | Action |
|---------------------|---|--|
| Wrong Ink Cartridge | The ink cartridge model number is not compatible with your machine. | Verify whether the cartridge model number will work with your machine. |
| Wrong Ink Color | An ink cartridge has been installed in the wrong position. | Check which ink cartridges are not matched by color to their ink cartridge positions and move them to their correct positions. |



Related Information

- [Troubleshooting](#)

Related Topics:

- [Touchscreen LCD Overview](#)
- [Print the Network Configuration Report](#)
- [Replace the Ink Cartridges](#)
- [Change the Check Paper Setting](#)
- [Load Paper](#)
- [Load Paper in the Manual Feed Slot](#)
- [Printer Jam or Paper Jam](#)
- [Clean the Paper Pick-up Rollers](#)
- [Change the Paper Size](#)
- [Print Settings \(Windows\)](#)
- [Paper is Jammed Inside and in the Front of the Machine \(Jam Inside/ Front\)](#)
- [Paper is Jammed in the Front of the Machine \(Jam Front\)](#)
- [Paper is Jammed in the Back of the Machine \(Jam Rear\)](#)
- [Paper Handling and Printing Problems](#)

Printer Jam or Paper Jam

Locate and remove the jammed paper.

- [Paper is Jammed Inside and in the Front of the Machine \(Jam Inside/ Front\)](#)
- [Paper is Jammed in the Front of the Machine \(Jam Front\)](#)
- [Paper is Jammed in the Back of the Machine \(Jam Rear\)](#)
- [Error and Maintenance Messages](#)
- [Paper Handling and Printing Problems](#)

Paper is Jammed Inside and in the Front of the Machine (Jam Inside/ Front)

If the LCD displays [Jam Inside/Front] or [Repeat Jam Inside/Front], follow these steps:

1. Unplug the machine from the AC power outlet.
2. Pull Tray #1 (1) completely out of the machine as shown by the arrow.

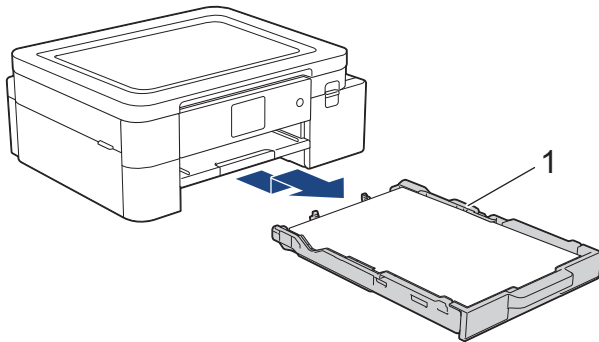

3. Lift the paper support (1), and then pull it at an angle completely out of the machine as shown by the arrow.

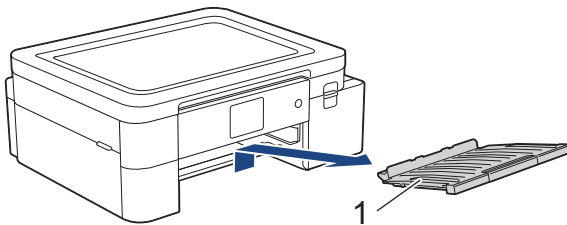

4. Slowly pull the jammed paper (1) out of the machine.

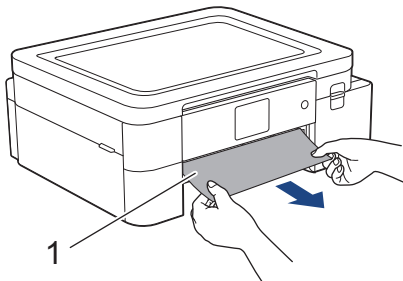

5. Place both hands under the plastic tabs on both sides of the machine to lift the top cover (1) into the open position.

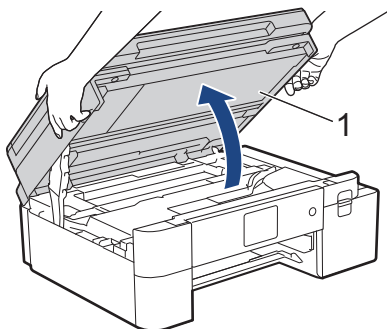

6. Slowly pull the jammed paper (1) out of the machine.

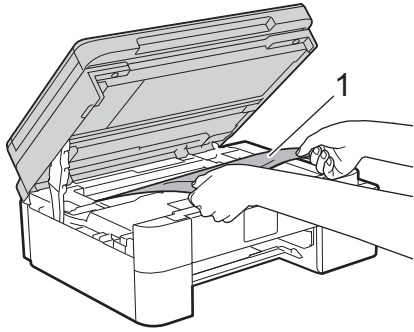

⚠ CAUTION

Black Sublimation Ink may cause an allergic reaction.

- If black ink accidentally gets on your skin, wash immediately with soap and cold water.
- If skin irritation or rash occurs, seek medical attention immediately.

IMPORTANT

- DO NOT touch the encoder strip, a thin strip of plastic that stretches across the width of the machine (1). Doing this may cause damage to the machine.

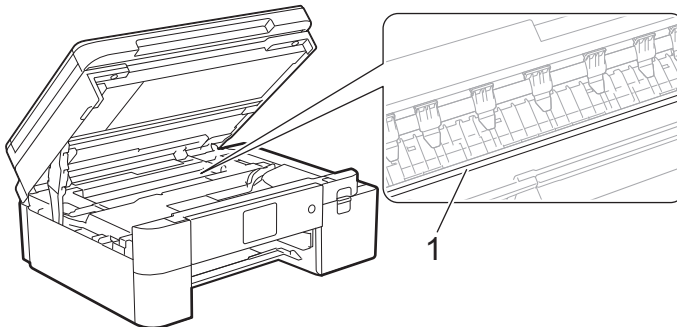

- If the print head is in the right corner as shown in the illustration (2), you cannot move it. Follow these steps:
 - a. Close the top cover, and then reconnect the power cord.
 - b. Open the top cover again, and then press and hold **X** until the print head moves to the center.
 - c. Unplug the machine from the power source and gently remove the jammed paper.

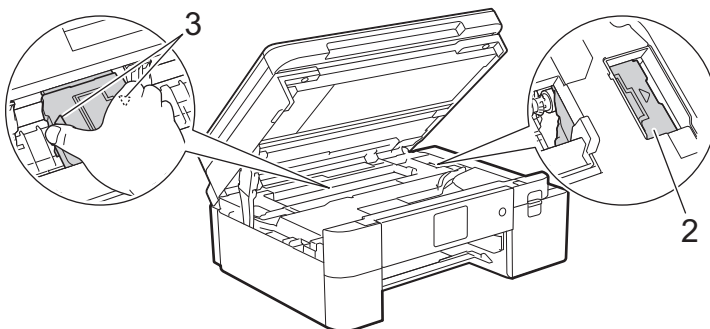

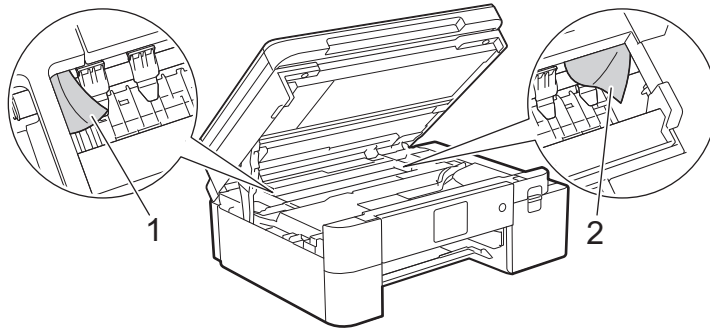

- If the paper is jammed under the print head, unplug the machine from the power source, and then move the print head to remove the paper. Hold the concave areas with the triangle marks as shown in the illustration (3) to move the print head.

 If your LCD error message was [Repeat Jam Inside/Front], move the print head (if needed) to remove any paper remaining in this area. Make sure scraps of paper are not left in the corners of the machine (1) and (2).

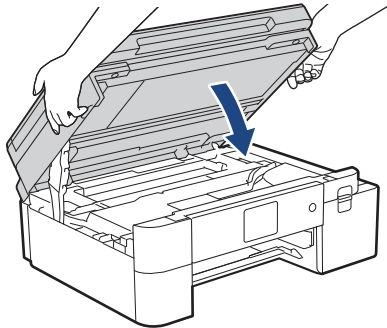

7. Gently close the top cover using both hands.



 If your LCD error message was [Repeat Jam Inside/Front], do the following:

- a. Make sure you look carefully inside (1) for any scraps of paper.

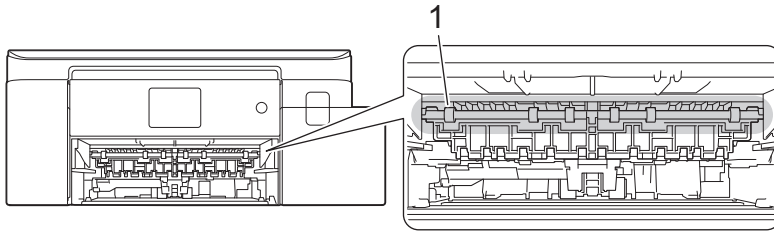

- b. Squeeze both levers (1), and then open the Jam Clear Cover at the back of the machine.

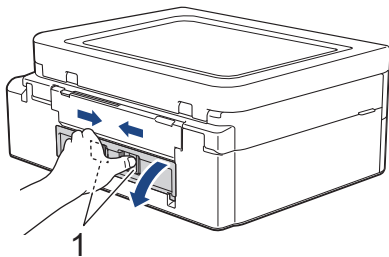

- c. Slowly pull the jammed paper out of the machine.

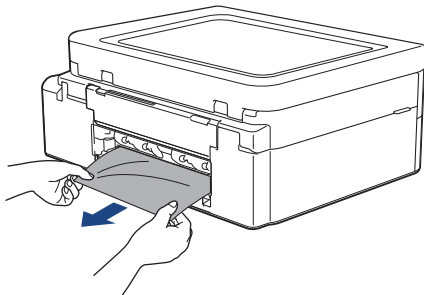

- d. Close the Jam Clear Cover. Make sure the cover is closed completely.

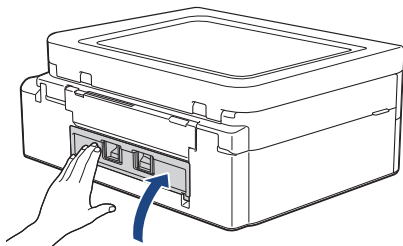

-
- 8. Put the paper support firmly back in the machine. Make sure you fit the paper support into the channels.

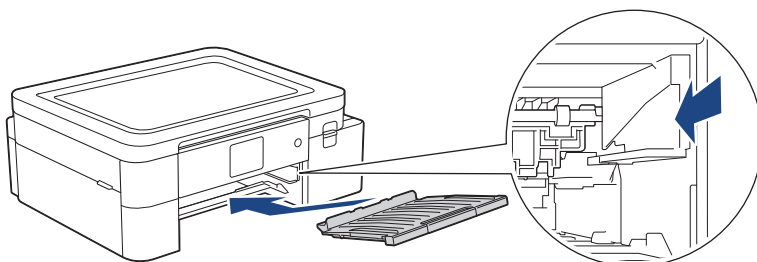

9. Slowly push Tray #1 completely into the machine.

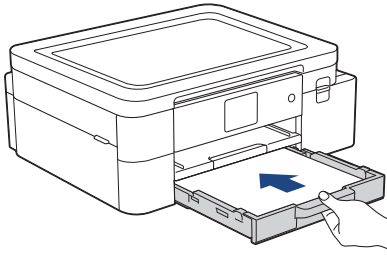

10. Pull out the paper support (1) until it locks into place, and then unfold the paper support flap (2).

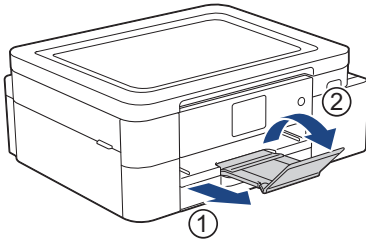

11. Reconnect the power cord.



Additional paper jam clear operations

If the LCD error message continues to appear and you repeatedly experience paper jams, do the following:

1. Unplug the machine from the AC power outlet and open the manual feed slot cover.
2. Load one sheet of thick A4 or Letter sized paper, such as glossy paper, in the manual feed slot. Insert the paper deep into the manual feed slot.

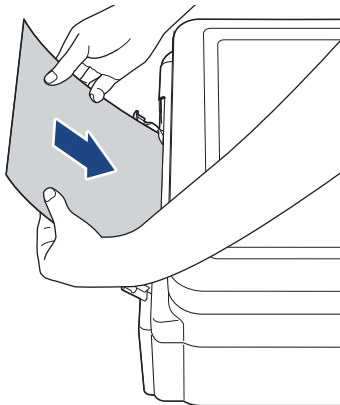

3. Re-connect the power cord.

The paper you placed in the manual feed slot will be fed through the machine and ejected. If the thick paper is pushing any jammed paper out, remove the jammed paper.

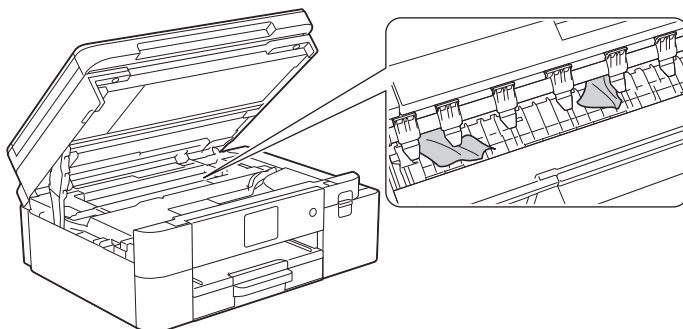



Related Information

- [Printer Jam or Paper Jam](#)

Related Topics:

- [Error and Maintenance Messages](#)
-

Paper is Jammed in the Front of the Machine (Jam Front)

If the LCD displays [Jam Front] or [Repeat Jam Front], follow these steps:

1. Unplug the machine from the AC power outlet.
2. Pull Tray #1 (1) completely out of the machine as shown by the arrow.

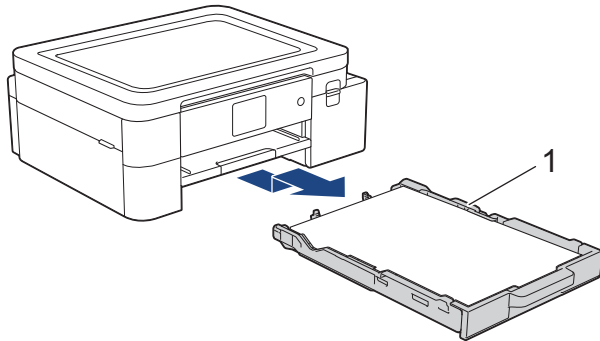

3. Lift the paper support (1), and then pull it at an angle completely out of the machine as shown by the arrow.

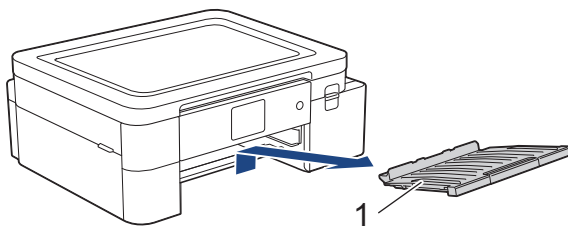

4. Slowly pull out the jammed paper (1).

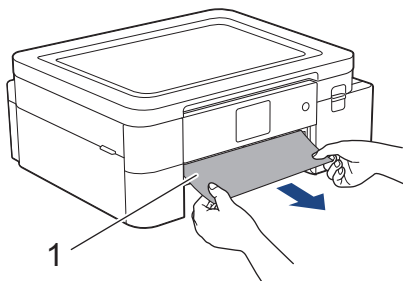

 If your LCD error message was [Repeat Jam Front], do the following:

- a. Make sure you look carefully inside (1) for any scraps of paper.

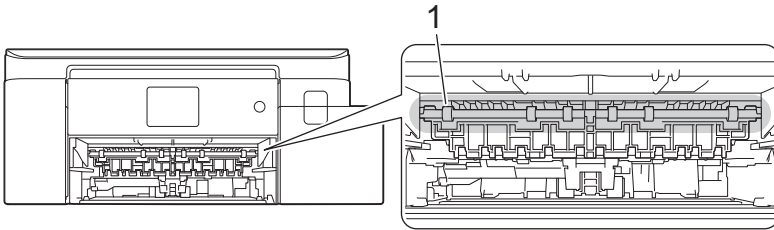

- b. Squeeze both levers (1), and then open the Jam Clear Cover at the back of the machine.

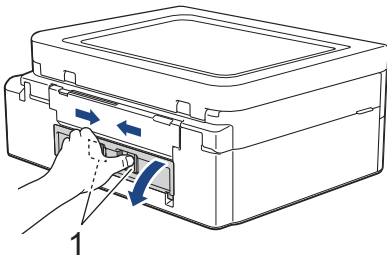

- c. Slowly pull the jammed paper out of the machine.

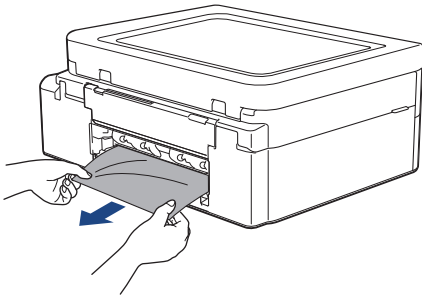

- d. Close the Jam Clear Cover. Make sure the cover is closed completely.

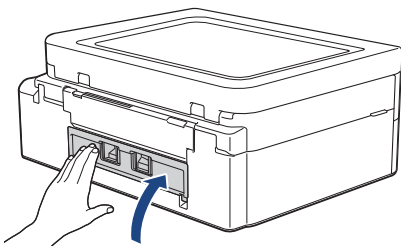

-
5. Put the paper support firmly back in the machine. Make sure you fit the paper support into the channels.

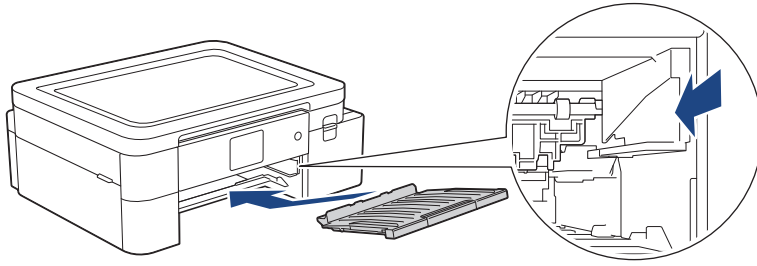

6. Slowly push Tray #1 completely into the machine.

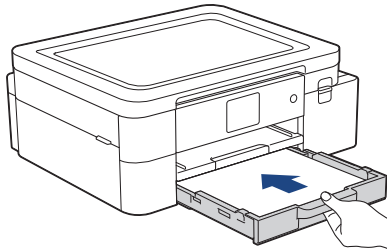

7. Pull out the paper support (1) until it locks into place, and then unfold the paper support flap (2).

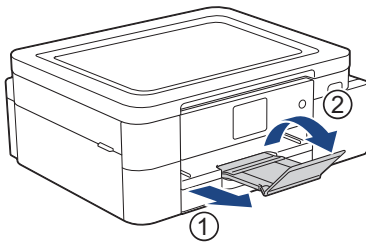

8. Reconnect the power cord.



Additional paper jam clear operations

If the LCD error message continues to appear and you repeatedly experience paper jams, do the following:

1. Unplug the machine from the AC power outlet and open the manual feed slot cover.
2. Load one sheet of thick A4 or Letter sized paper, such as glossy paper, in the manual feed slot. Insert the paper deep into the manual feed slot.

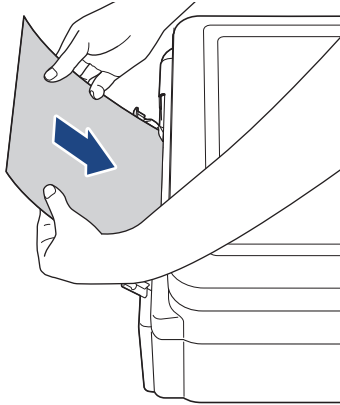

3. Re-connect the power cord.

The paper you placed in the manual feed slot will be fed through the machine and ejected. If the thick paper is pushing any jammed paper out, remove the jammed paper.

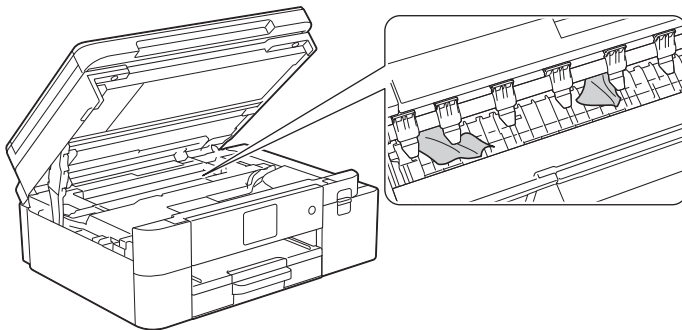

Related Information

- [Printer Jam or Paper Jam](#)

Related Topics:

- [Error and Maintenance Messages](#)
-

Paper is Jammed in the Back of the Machine (Jam Rear)

If the LCD displays [Jam Rear], follow these steps:

1. Unplug the machine from the AC power outlet.
2. Pull Tray #1 (1) completely out of the machine as shown by the arrow.

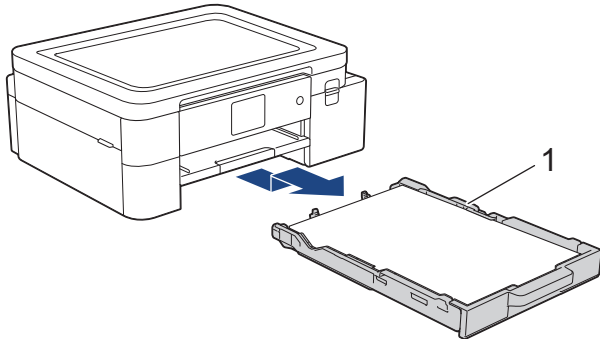

3. Lift the paper support (1), and then pull it at an angle completely out of the machine as shown by the arrow.

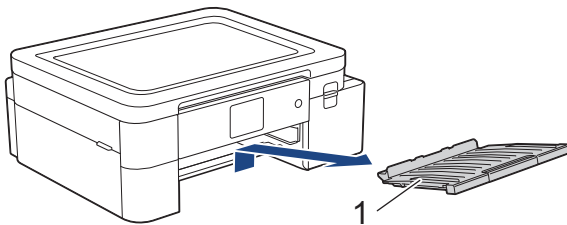

 Depending on the paper size, it is easier to remove the jammed paper from the front of the machine rather than from the back of the machine.

4. Squeeze both levers (1), and then open the Jam Clear Cover at the back of the machine.

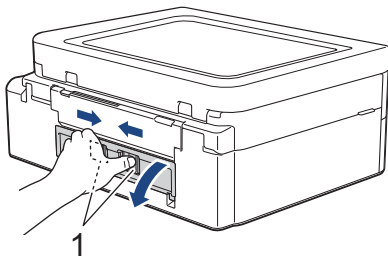

5. Slowly pull the jammed paper out of the machine.

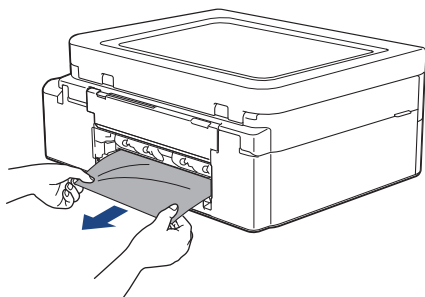

6. Close the Jam Clear Cover. Make sure the cover is closed completely.

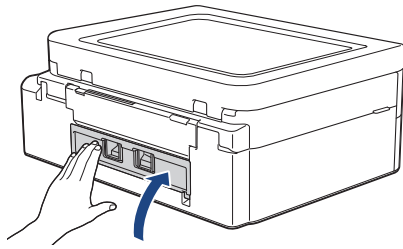

7. Put the paper support firmly back in the machine. Make sure you fit the paper support into the channels.

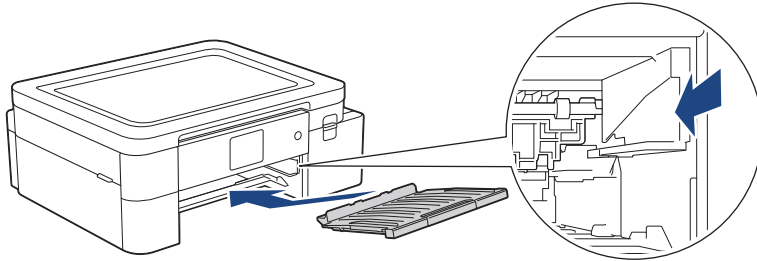

8. Slowly push Tray #1 completely into the machine.

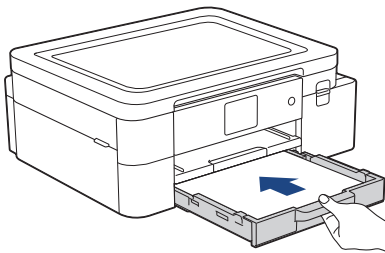

9. Pull out the paper support (1) until it locks into place, and then unfold the paper support flap (2).

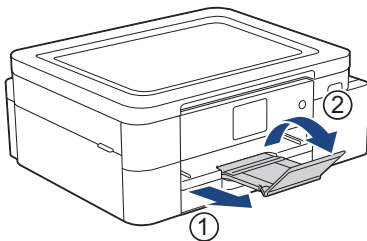

10. Reconnect the power cord.

Related Information

- [Printer Jam or Paper Jam](#)

Related Topics:

- [Error and Maintenance Messages](#)

If You Are Having Difficulty with Your Machine



For technical help, you must call the country where you bought the machine. Calls must be made from within that country.

If you think there is a problem with your machine, check the following topics. You can correct most problems yourself.

If you need additional help, go to your model's **FAQs & Troubleshooting** page at <https://s.brother/cf2ab/>.

- [Paper Handling and Printing Problems](#)
- [Other Problems](#)
- [Network Problems](#)
- [AirPrint Problems](#)
- [Artspira Problems](#)

Paper Handling and Printing Problems





If, after reading this table, you still need help, see the latest **FAQs & Troubleshooting** tips at <https://s.brother/cf2ab/>.

>> [Printing Difficulties](#)

>> [Print Quality Difficulties](#)







>> [Paper Handling Difficulties](#)

Printing Difficulties

| Difficulties | Suggestions |
|--|--|
| No printout | <p>(Windows)</p> <p>Check that the correct printer driver has been installed and selected.</p> <p>Check to see if the machine's display is showing an error message. See <i>Related Information: Error and Maintenance Messages</i>.</p> <p>Check that the machine is online:</p> <ul style="list-style-type: none"> Windows 11 Click  > All apps > Windows Tools > Control Panel. In the Hardware and Sound group, click View devices and printers. Right-click your model's icon, and click See what's printing. If printer driver options appear, select your printer driver. Click Printer in the menu bar and make sure Use Printer Offline is not selected. Windows 10 Click  > Windows System > Control Panel. In the Hardware and Sound group, click View devices and printers. Right-click your model's icon, and click See what's printing. If printer driver options appear, select your printer driver. Click Printer in the menu bar and make sure Use Printer Offline is not selected. <p>One or more ink cartridges have reached the end of their life. See <i>Related Information: Replace the Ink Cartridges</i>.</p> <p>If old, unprinted data remains in the printer driver spooler, it will prevent new print jobs from printing. Open the printer icon and delete all data as follows:</p> <ul style="list-style-type: none"> Windows 11 Click  > All apps > Windows Tools > Control Panel. In the Hardware and Sound group, click View devices and printers > Printers. Windows 10 Click  > Windows System > Control Panel. In the Hardware and Sound group, click View devices and printers > Printers. Mac Click the System Preferences > Printers & Scanners. |
| The headers or footers appear when the document is displayed on the screen but do not appear when the document is printed. | <p>There is an unprintable area on the top and bottom of the page. Adjust the top and bottom margins in your document to allow for this. See <i>Related Information: Unprintable Area</i>.</p> |
| Cannot perform 'Page Layout' printing. | <p>(Windows)</p> <p>Check that the paper size setting in the application and in the printer driver are the same.</p> |
| Print speed is too slow. | <p>(Windows)</p> <p>Try changing the printer driver setting. The highest resolution needs longer data processing, sending, and printing time. Try the other quality settings in the printer driver as follows: In the printer driver, clear the Color Enhancement (True2Life) checkbox on the Advanced tab.</p> |

| Difficulties | Suggestions |
|---------------------------------|--|
| Printout image is not mirrored. | Depending on the output you want to create and the images you use, you may need to print a mirror, or horizontally-reversed, image. The default settings for mirror printing differ depending on the application you print from. Check the settings before printing. If your application does not have mirror print settings, you must manually create an horizontally-reversed image before printing. |

Print Quality Difficulties

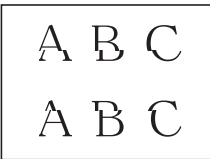
| Difficulties | Suggestions |
|--|--|
| Poor print quality | <p>Check the print quality. See <i>Related Information: Check the Print Quality.</i></p> <p>Make sure your ink cartridges are fresh. The following may cause ink to clog:</p> <ul style="list-style-type: none"> • The expiration date written on the cartridge package has passed. • The ink cartridge may not have been stored correctly before use. <p>Make sure you are using one of the recommended types of paper. See <i>Related Information: Acceptable Print Media.</i></p> <p>The recommended environment for your machine is between 68 °F to 91.4 °F (20°C to 33°C).</p> |
| White lines appear in text or graphics.  | <p>Clean the print head. See <i>Related Information: Clean the Print Head from Your Brother Machine.</i> See <i>Related Information: Clean the Print Head Using Web Based Management.</i> See <i>Related Information: Clean the Print Head from Your Computer (Windows).</i></p> <p>Check and adjust the paper feed. See <i>Related Information: Correct the Paper Feed to Clear Vertical Lines.</i></p> <p>Try using the recommended types of paper. See <i>Related Information: Acceptable Print Media.</i></p> <p>To prolong print head life, provide the best ink cartridge economy, and maintain print quality, keep your machine connected to a power source at all times. We recommend using  to power down the machine. Using  allows minimal power to the machine, resulting in periodic, cleaning of the print head.</p> |
| Dark lines appear at regular intervals.  | <p>Check and adjust the paper feed. See <i>Related Information: Correct the Paper Feed to Clear Vertical Lines.</i></p> |
| The machine prints blank pages. | <p>Check the print quality. See <i>Related Information: Check the Print Quality.</i></p> <p>To prolong print head life, provide the best ink cartridge economy, and maintain print quality, keep your machine connected to a power source at all times. We recommend using  to power down the machine. Using  allows minimal power to the machine, resulting in periodic, cleaning of the print head.</p> |
| Characters and lines are blurred.  | <p>Change the print options. See <i>Related Information: Change the Print Options to Improve Your Print Results.</i></p> |

| Difficulties | Suggestions |
|--|--|
| Printed text or images are skewed. | Make sure the paper is loaded correctly in the paper tray and the paper guides are adjusted correctly. See <i>Related Information: Load Paper</i> . |
| | Make sure the Jam Clear Cover is closed correctly. |
| There are smudges or stains at the top center of the printed page. | Make sure the paper is not too thick or curled. See <i>Related Information: Acceptable Print Media</i> . |
| Printing appears dirty or ink seems to run. | Make sure you are using the recommended types of paper. Do not handle the paper until the ink is dry. See <i>Related Information: Acceptable Print Media</i> . |
| | Make sure the printing surface is face down in the paper tray. |
| Stains appear on the reverse side or at the bottom of the page. | Make sure the printer platen is not dirty with ink. See <i>Related Information: Clean the Machine's Printer Platen</i> . |
| | Make sure you are using the paper support flap. See <i>Related Information: Load Paper</i> . |
| | Make sure the paper feed rollers are not dirty with ink. See <i>Related Information: Clean the Paper Feed Rollers</i> . |
| Vertical dotted lines appears on the printout. | Make sure to use the machine in the recommended environment. The recommended environment for your machine is between 68°F to 91.4°F (20°C to 33°C). |
| | Change the print option. Set the [Reduce Smudging] option to [On]. (Windows) Set the Reduce Smudge option to On . See <i>Related Information: Change the Print Options to Improve Your Print Results</i> . See <i>Related Information: Prevent Smudged Printouts and Paper Jams (Windows)</i> . |

Paper Handling Difficulties

| Difficulties | Suggestions |
|----------------------------------|---|
| The machine does not feed paper. | Make sure the paper tray is pushed in all the way until it locks into place. |
| | Make sure the Jam Clear Cover at the back of the machine is closed. |
| | If the machine's LCD displays a Paper Jam message and you still have a problem, see <i>Related Information: Error and Maintenance Messages</i> . |
| | If the paper tray is empty, load a new stack of paper into the paper tray. |
| | If there is paper in the paper tray, make sure it is straight. If the paper is curled, straighten it. Sometimes it is helpful to remove the paper, turn the stack over and put it back in the paper tray. |
| | Reduce the amount of paper in the paper tray, and then try again. |
| | Clean the paper pick-up rollers. See <i>Related Information: Clean the Paper Pick-up Rollers</i> . |
| | Make sure that the paper is within specifications for the machine. See <i>Related Information: Paper Tray Capacity</i> . |
| Machine feeds multiple pages. | <ul style="list-style-type: none"> • Make sure the paper is loaded correctly in the paper tray. • Remove all the paper from the tray and fan the stack of paper well, then put it back in the tray. • Make sure you do not push the paper in too far. See <i>Related Information: Load Paper</i> . |
| | Make sure the Jam Clear Cover is closed correctly. See <i>Related Information: Printer Jam or Paper Jam</i> . |
| | Make sure the Base Pad in the paper tray is not dirty. See <i>Related Information: Clean the Base Pad</i> . |

| Difficulties | Suggestions |
|-----------------------|--|
| There is a paper jam. | <p>See <i>Related Information: Printer Jam or Paper Jam</i>. Make sure the paper guides are set to the correct paper size.</p> <p>Use the jam prevention settings. For printing: See <i>Related Information: Change the Print Options to Improve Your Print Results</i>. See <i>Related Information: Prevent Smudged Printouts and Paper Jams (Windows)</i>.</p> |



Related Information

- [If You Are Having Difficulty with Your Machine](#)

Related Topics:

- [Troubleshooting](#)
- [Error and Maintenance Messages](#)
- [Replace the Ink Cartridges](#)
- [Unprintable Area](#)
- [Check the Print Quality](#)
- [Change the Paper Size](#)
- [Acceptable Print Media](#)
- [Clean the Print Head from Your Brother Machine](#)
- [Clean the Print Head from Your Computer \(Windows\)](#)
- [Load Paper](#)
- [Clean the Machine's Printer Platen](#)
- [Clean the Paper Feed Rollers](#)
- [Clean the Paper Pick-up Rollers](#)
- [Printer Jam or Paper Jam](#)
- [Print Settings \(Windows\)](#)
- [Prevent Smudged Printouts and Paper Jams \(Windows\)](#)
- [Clean the Base Pad](#)
- [Change the Print Options to Improve Your Print Results](#)
- [Correct the Paper Feed to Clear Vertical Lines](#)
- [Clean the Print Head Using Web Based Management](#)
- [Paper Tray Capacity](#)

Other Problems

Software Difficulties

| Difficulties | Suggestions |
|---|--|
| Cannot print. | Uninstall the drivers (Windows) and the Brother software and reinstall the latest version of both. |
| "The device is busy." appears on the computer screen. | Make sure there is no error message on the machine's display. |

Related Information

- [If You Are Having Difficulty with Your Machine](#)

Related Topics:

- [Troubleshooting](#)
-

Network Problems

- [Use the Network Connection Repair Tool \(Windows\)](#)
- [Check Your Machine's Network Settings](#)
- [If You Are Having Difficulty with Your Machine's Network](#)
- [Troubleshooting](#)

Use the Network Connection Repair Tool (Windows)

Use the Network Connection Repair Tool to fix the Brother machine's network settings. It will assign the correct IP address and Subnet Mask.

Make sure your machine is turned on and is connected to the same network as your computer.

1. Launch  (**Brother Utilities**), and then click the drop-down list and select your model name (if not already selected).
2. Click **Tools** in the left navigation bar, and then click **Network Connection Repair Tool**.
3. Follow the on-screen instructions.
4. Check the diagnosis by printing the Network Configuration Report.



The Network Connection Repair Tool will start automatically if you select the **Enable Connection Repair Tool** option in the Status Monitor. Right-click the Status Monitor screen, and then click **Other Settings > Enable Connection Repair Tool**. This is not recommended when your network administrator has set the IP address to Static, since it will automatically change the IP address.

If the correct IP address and the Subnet Mask are still not assigned even after using the Network Connection Repair Tool, ask your network administrator for this information.



Related Information

- [Network Problems](#)

Related Topics:

- [If You Are Having Difficulty with Your Machine's Network](#)
 - [Print the Network Configuration Report](#)
-

Check Your Machine's Network Settings

- [Print the Network Configuration Report](#)
- [Change Machine Settings Using Web Based Management](#)

If You Are Having Difficulty with Your Machine's Network



For technical help, you must call the country where you bought the machine. Calls must be made from within that country.

If you think there is a problem with your machine, check the following topics. You can correct most problems yourself.

If you need additional help, go to your model's **FAQs & Troubleshooting** page at <https://s.brother/cf2ab/>.

>> [I Cannot Complete the Wireless Network Setup Configuration](#)

>> [My Brother Machine Cannot Print over the Network](#)

>> [I Want to Check that My Network Devices are Working Correctly](#)

I Cannot Complete the Wireless Network Setup Configuration

Turn your wireless router off and back on. Then, try to configure the wireless settings again. If you are unable to resolve the problem, follow the instructions below:

Investigate the problem using the WLAN Report.



| Cause | Action | Interface |
|---|--|--------------|
| Your security settings (SSID/ Network Key) are not correct. | Confirm the security settings using Wireless Setup Helper . For more information and to download this utility, go to your model's Downloads page at https://s.brother/ca2ab/ . Select and confirm that you are using the correct security settings. <ul style="list-style-type: none"> - See the instructions supplied with your wireless LAN access point/router for information on how to find the security settings. - The manufacturer's name or model number of the wireless LAN access point/router may be used as the default security settings. - Consult with the access point/router manufacturer, your Internet provider, or network administrator. | Wireless |
| Your Brother machine's MAC address is not allowed. | Confirm that the Brother machine's MAC Address is allowed in the filter. You can find the MAC Address on your Brother machine's control panel. | Wireless |
| Your wireless LAN access point/router is in stealth mode (not broadcasting the SSID). | <ul style="list-style-type: none"> • Enter the correct SSID name or Network Key manually. • Check the SSID name or the Network Key in the instructions supplied with your wireless LAN access point/router and reconfigure the wireless network setup. | Wireless |
| Your security settings (SSID/ password) are not correct. | Confirm the SSID and password. When you are configuring the network manually, the SSID and password are displayed on your Brother machine. If your mobile device supports the manual configuration, the SSID and password will be displayed on your mobile device's screen. | Wi-Fi Direct |
| You are using Android™ 4.0. | If your mobile device disconnects (approximately six minutes after using Wi-Fi Direct), try the one-push configuration using WPS (recommended) and set the Brother machine as a Group Owner. | Wi-Fi Direct |
| Your Brother machine is placed too far from your mobile device. | Move your Brother machine within about 3.3 feet (1 meter) of the mobile device when you configure the Wi-Fi Direct network settings. | Wi-Fi Direct |
| There are some obstructions (walls or furniture, for example) between your machine and the mobile device. | Move your Brother machine to an obstruction-free area. | Wi-Fi Direct |

| Cause | Action | Interface |
|---|---|--------------|
| There is a wireless computer, Bluetooth®-supported device, microwave oven, or digital cordless phone near the Brother machine or the mobile device. | Move other devices away from the Brother machine or the mobile device. | Wi-Fi Direct |
| You have checked and tried all of the above, but your Brother machine still cannot complete the Wi-Fi Direct configuration. | <ul style="list-style-type: none"> • Turn your Brother machine off and back on. Then, try to configure the Wi-Fi Direct settings again. • If you are using your Brother machine as a client, confirm how many devices are allowed in the current Wi-Fi Direct network, and then check how many devices are connected. | Wi-Fi Direct |

For Windows

If your wireless connection has been interrupted, and you have checked and tried all of the above, we recommend using the Network Connection Repair Tool.

My Brother Machine Cannot Print over the Network

| Cause | Action | Interface |
|---|---|----------------|
| Your Brother machine suddenly stopped printing. | <ol style="list-style-type: none"> 1. Press  > [Recover WLAN]. 2. When your wireless device connects successfully, the machine displays [Connected]. Press [OK]. | Wireless |
| Your security software blocks your machine's access to the network. | Some security software might block access without showing a security alert dialog box even after successful installation. To allow access, see the instructions for your security software or ask the software manufacturer. | Wired/Wireless |
| Your Brother machine was not assigned an available IP address. | <ul style="list-style-type: none"> • Confirm the IP address and the Subnet Mask. Verify that both the IP addresses and Subnet Masks of your computer and the Brother machine are correct and located on the same network. For more information about how to verify the IP address and the Subnet Mask, ask your network administrator. • Windows Confirm the IP address and the Subnet Mask using the Network Connection Repair Tool. • Mac Check your network devices using the ping command. For more information on how to confirm your network settings, see <i>Related Information: Check Network Devices Using the Ping Command</i>. | Wired/Wireless |
| The failed print job is still in your computer's print queue. | <ul style="list-style-type: none"> • If the failed print job is still in your computer's print queue, delete it. • Otherwise, double-click the printer icon in the following folder and cancel all documents: <ul style="list-style-type: none"> - Windows 11 Click  > All apps > Windows Tools > Control Panel. In the Hardware and Sound group, click View devices and printers. - Windows 10 Click  > Windows System > Control Panel. In the Hardware and Sound group, click View devices and printers. - Mac Click System Preferences > Printers & Scanners. | Wired/Wireless |

| Cause | Action | Interface |
|--|--|-----------|
| Your Brother machine is not connected to the wireless network. | Print the WLAN Report to check the error code on the printed report. | Wireless |

If you have checked and tried all of the above, but your Brother machine still cannot print, uninstall the drivers (Windows) and the Brother software and reinstall the latest version of both.

I Want to Check that My Network Devices are Working Correctly

| Cause | Action | Interface |
|--|--|----------------|
| Check that your Brother machine, access point/router, or network hub is turned on. | Check the following: <ul style="list-style-type: none"> The power cord is connected correctly and the Brother machine is turned on. The access point/router or hub is turned on and its link indicator is blinking. All protective packaging has been removed from the machine. The ink cartridges are installed correctly. The Top Cover and the Jam Clear Cover are fully closed. Paper is inserted correctly in the paper tray. (For wired networks) A network cable is securely connected to the Brother machine and to the router or hub. | Wired/Wireless |
| Check that you can "ping" the Brother machine from your computer. | Ping the Brother machine from your computer using the IP address or the node name in the Windows command prompt or Mac Terminal application: ping <ipaddress> or <nodename>. <ul style="list-style-type: none"> Successful: Your Brother machine is working correctly and connected to the same network as your computer. Unsuccessful: Your Brother machine is not connected to the same network as your computer. Windows: Ask your administrator about the IP address and the subnet mask, and then use the Network Connection Repair Tool. Mac: Confirm that the IP address and the Subnet Mask are set correctly. | Wired/Wireless |
| Check that your Brother machine is connected to the wireless network. | Print the WLAN Report to check the error code on the printed report. | Wireless |

If you have checked and tried all of the above but you are still having problems, see the instructions supplied with your wireless LAN access point/router to find the SSID (Network Name) and the Network Key (Password) information and set them correctly.

Related Information

- [Network Problems](#)
 - [Check Network Devices Using the Ping Command](#)

Related Topics:



- [Print the WLAN Report](#)
- [Use the Network Connection Repair Tool \(Windows\)](#)
- [Wireless LAN Report Error Codes](#)
- [Configure Your Machine for a Wireless Network When the SSID is Not Broadcast](#)
- [Use Wi-Fi Direct®](#)
- [Print the Network Configuration Report](#)

Check Network Devices Using the Ping Command

Check the IP addresses of both your computer and your Brother machine, and then confirm whether the network is operating correctly.

- >> [Configure the IP Address on your computer \(Windows\)](#)
- >> [Configure the IP Address on your computer \(Mac\)](#)
- >> [Configure the IP Address on your Brother machine](#)

Configure the IP Address on your computer (Windows)

- Do one of the following:
 - Windows 11
Click  > **All apps** > **Windows Tools** > **Command Prompt**.
 - Windows 10
Click  > **Windows System** > **Command Prompt**.
- Type "ipconfig" and then press the Enter key on your keyboard.
- Confirm the values for the IPv4 address and subnet mask.
- Type "exit" and then press the Enter key on your keyboard.

Configure the IP Address on your computer (Mac)

- Select **System Preferences** from the Apple menu.
- Click **Network** > **Advanced** > **TCP/IP**.
- Confirm the values for the IPv4 address and subnet mask.

Configure the IP Address on your Brother machine

Print the Network Configuration Report, and confirm the values for the IP address and subnet mask.

| | | |
|----------------|-----------------|----------------|
| <IP Settings > | | |
| IP Address | 192.168.11.250 | (set manually) |
| Subnet Mask | 255.255.255.0 | |
| IP Gateway | 192.168.100.200 | |
| Boot Method | STATIC | |
| Boot Tries | 3 | |
| IP Filter | Disabled | |

Check the IP addresses for both your computer and your Brother machine. Confirm that the network address portions are the same. For example, if the subnet mask is "255.255.255.0", it is normal for only the host address portions to be different.

| | Network Address | Host Address | |
|-------------|-----------------|--------------|---|
| IP Address | 192.168.100. | 250 | Set the final number, which corresponds to "0" in the subnet mask, to 1–254. |
| Subnet Mask | 255.255.255. | 0 | Usually, there are no problems when the subnet mask is "255.255.255.0". Use the same value for all of your computers. |

Related Information

- [If You Are Having Difficulty with Your Machine's Network](#)

AirPrint Problems

| Difficulty | Suggestions |
|--|--|
| My machine is not displayed in the printer list. | Make sure your machine is turned on. |
| | Confirm the network settings. |
| | Move the mobile device closer to the wireless access point/router, or to your machine. |
| I cannot print. | Make sure your machine is turned on. |
| | Confirm the network settings. |
| I am trying to print a multiple-page document from an iOS device, but ONLY the first page is printing. | Make sure you are running the latest OS version. |



Related Information

- [If You Are Having Difficulty with Your Machine](#)

Related Topics:

- [Troubleshooting](#)
-

Artspira Problems

| Difficulty | Suggestions |
|--|---|
| My machine does not appear in the printer list. | Make sure your machine is turned on. |
| | Confirm your network settings. |
| | Move your mobile device closer to your wireless access point/router, or to your machine. |
| | Restart the application or reboot your mobile device. |
| I cannot print. | Make sure your machine is turned on. |
| | Confirm your network settings. |
| | Make sure you have selected your machine in the Artspira app. |
| | Restart the application or reboot your mobile device. |
| Creative Printer does not appear on the Machine Settings screen. | Make sure that you are using the latest version of the Artspira app. |
| | Make sure that you have selected the correct region in Artspira's User Information settings. |



Related Information

- [If You Are Having Difficulty with Your Machine](#)

Related Topics:

- [Troubleshooting](#)
-

Check the Machine Information

Follow these instructions to check your machine's serial number, firmware version, and firmware update.

1. Press  [Settings] > [All Settings] > [Machine Info.].
2. Press one of the following options:

| Option | Description |
|---------------------|--|
| Serial No. | Check your machine's serial number. |
| Firmware Version | Check your machine's firmware version. |
| Firmware Update | Update your machine to the latest firmware. |
| Firmware Auto Check | View firmware information on the Home screen. |
| Page Counter | Check the number of total pages the machine has printed. |

3. Press .

Related Information

- [Troubleshooting](#)
-

Reset Your Machine

1. Press  [Settings] > [All Settings] > [Initial Setup] > [Reset].
2. Press the reset option you want to use.
3. Press [OK] for two seconds to reboot the machine.



Related Information

- [Troubleshooting](#)
 - [Reset Functions Overview](#)
-

Reset Functions Overview

The following reset functions are available:

1. [Machine Reset]
You can reset all the machine's settings that you have changed.
2. [Network]
Reset the print server back to its default factory settings (includes Password and IP Address information).
3. [All Settings]
Use this reset function to reset all of the machine's settings to the settings originally set at the factory.
We strongly recommend you perform this operation when you dispose of the machine.



Unplug the interface cable before you select [Network] or [All Settings].



Related Information

- [Reset Your Machine](#)
-

Routine Maintenance

CAUTION

- Black Sublimation Ink may cause an allergic reaction.
- Wear a protective gloves when there is a possibility of touching the ink, such as when replacing the ink cartridges or performing routine maintenance inside the product.
- If the ink accidentally gets on your skin, wash immediately with soap and cold water. If skin irritation or rash occurs, seek medical attention immediately.

Related Information

Related Topics:

- [Disposing of Used Consumables](#)
 - [Replace the Ink Cartridges](#)
 - [Clean Your Brother Machine](#)
 - [Check Your Brother Machine](#)
 - [Correct the Paper Feed to Clear Vertical Lines](#)
 - [Change the Print Options to Improve Your Print Results](#)
 - [Pack and Ship Your Machine](#)
-

Disposing of Used Consumables

The following materials are classified as industrial waste. Please dispose of the following items in accordance with local regulations:

- Empty Sublimation Ink cartridges
- Paper with Sublimation Ink on it



Related Information

- [Routine Maintenance](#)

Related Topics:

- [Replace the Ink Cartridges](#)
-

Replace the Ink Cartridges

Your Brother machine is equipped with an ink dot counter. The ink dot counter automatically monitors the level of ink in each of the four ink cartridges. When the machine detects that an ink cartridge is running out of ink, the machine will display a message.

The LCD displays which ink cartridge needs replacing. Be sure to follow the LCD prompts to replace the ink cartridges in the correct order.

Even though the machine tells you to replace an ink cartridge, there will be a small amount of ink left in the ink cartridge.

⚠ CAUTION

Black Sublimation Ink may cause an allergic reaction.

- If the ink accidentally gets on your skin, wash immediately with soap and cold water.
- If skin irritation or rash occurs, seek medical attention immediately.

IMPORTANT

We recommend using genuine Brother supplies to ensure stable print quality and performance. Although not all non-genuine supplies may cause quality issues, it is possible that some may adversely affect print quality or cause machine malfunction. Brother may charge for repairing your machine if it is proven that non-genuine supplies caused the damage, even if the machine is still covered by the warranty.

1. Open the ink cartridge cover (1).

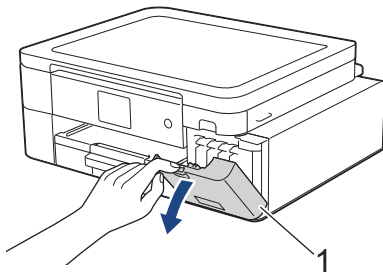

2. Press the lock release lever to release the ink cartridge color indicated on the LCD and remove the ink cartridge from the machine, as shown in the illustration.

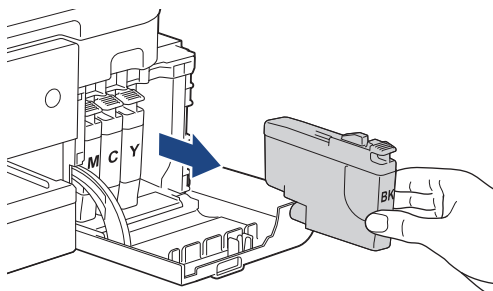
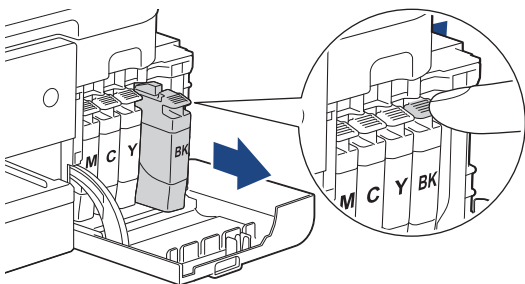

-
3. Open the new ink cartridge bag for the color indicated on the LCD, and take out the ink cartridge.

IMPORTANT

- DO NOT touch the ink cartridge in the area indicated (1); this can prevent the machine from detecting the cartridge.

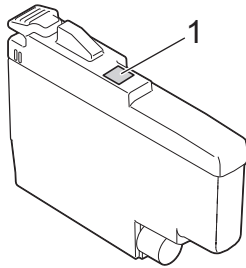

- Quickly shake each ink cartridge horizontally 15 times as shown, before inserting it into the machine.

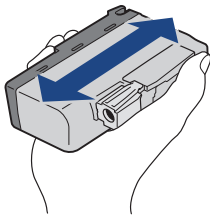

-
4. Insert the ink cartridge in the direction of the arrow on the label.
Each color has its own correct position.

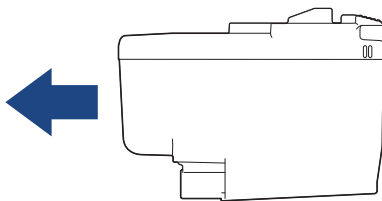

5. Gently push the area marked "PUSH" until the ink cartridge locks into place, and then close the ink cartridge cover.

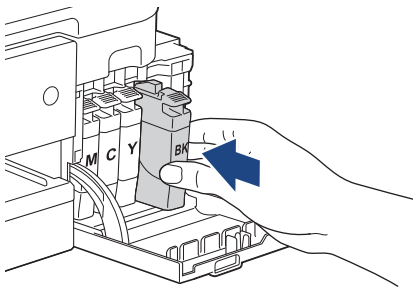

The machine resets the ink dot counter.



If the machine does not detect the ink cartridge after you install it, check that the ink cartridge is installed correctly. Remove the ink cartridge and reinstall it slowly until it locks into place.

IMPORTANT

- DO NOT shake the ink cartridges, once installed into the machine. If ink stains your skin or clothing, wash with soap or detergent at once.
- DO NOT remove ink cartridges if you do not need to replace them; otherwise, the machine will not know the ink quantity left in the cartridge.
- DO NOT touch the ink cartridge insertion slots; the ink may stain your skin.
- If you mix the colors by installing an ink cartridge in the wrong position, the LCD shows [Wrong Ink Color].
Check which ink cartridges are not matched by color to their ink cartridge positions and move them to their correct positions.
- Use unopened ink cartridges by the expiration date written on the ink cartridge package.
- DO NOT dismantle or tamper with the ink cartridge; this can cause the ink to leak out of the ink cartridge.



Related Information

- [Routine Maintenance](#)

Related Topics:

- [Error and Maintenance Messages](#)
 - [Paper Handling and Printing Problems](#)
 - [Pack and Ship Your Machine](#)
-

Clean Your Brother Machine

- [Clean the Print Head from Your Brother Machine](#)
- [Clean the Print Head Using Web Based Management](#)
- [Clean the Print Head from Your Computer \(Windows\)](#)
- [Clean the Machine's LCD](#)
- [Clean the Outside of the Machine](#)
- [Clean the Machine's Printer Platen](#)
- [Clean the Paper Feed Rollers](#)
- [Clean the Base Pad](#)
- [Clean the Paper Pick-up Rollers](#)

Clean the Print Head from Your Brother Machine

To maintain good print quality, the machine automatically cleans the print head when needed. If there is a print quality problem, start the cleaning process manually.

- Clean the print head if there is a horizontal line or a blank space in the text or graphics on printed pages. Depending on the problem color, select to clean Black only, three colors at a time (Yellow/Cyan/Magenta), or all four colors at once.
- Cleaning the print head consumes ink.
- Cleaning too often uses ink unnecessarily.

IMPORTANT



DO NOT touch the print head. Touching the print head may cause permanent damage and may void the print head's warranty.

1. Press  [Ink] > [Print Head Cleaning].
2. Press [Black only], [Color only], or [All].
3. Press [Normal], [Strong], or [Strongest].
4. Press [Start].

The machine cleans the print head.

NOTE

If you clean the print head several times and the print has not improved, try the Special cleaning method. The Special cleaning method uses the most power in cleaning the print head, but also consumes the most ink.

1. Press  [Ink] > [Print Head Cleaning].
2. Press  for five seconds.

The machine starts cleaning.



- The Special cleaning method requires a large amount of ink to clean the print head.
- Use the Special cleaning method only if you previously cleaned the print head several times and the print quality did not improve.
- You can also clean the print head from your computer.



Related Information

- [Clean Your Brother Machine](#)

Related Topics:

- [Paper Handling and Printing Problems](#)
 - [Clean the Print Head from Your Computer \(Windows\)](#)
 - [Clean the Print Head Using Web Based Management](#)
-

Clean the Print Head Using Web Based Management

To maintain good print quality, the machine automatically cleans the print head when needed. If there is a print quality problem, start the cleaning process manually.

If this option is not available, update your machine's firmware. Go to your model's **Downloads** page at <https://s.brother/ca2ab/>.

1. Start your web browser.
2. Type "https://machine's IP address" in your browser's address bar (where "machine's IP address" is the machine's IP address).
For example:
https://192.168.1.2
3. If required, type the password in the **Login** field, and then click **Login**.



The default password to manage this machine's settings is located on the back of the machine and marked "**Pwd**".

4. Go to the navigation menu, and then click **General > Print Head Cleaning**.



Start from , if the navigation menu is not shown on the left side of the screen.

5. Select the **Normal**, **Strong**, or **Strongest** option for the cleaning strength you want. The **Special** option uses the most power in cleaning the print head, but also consumes the most ink.
6. Click **Start**.



- The **Special** option requires a large amount of ink to clean the print head.
- Use the **Special** option only if you previously used the **Strongest** option and the print quality did not improve.

7. Click **Yes**.
The machine starts cleaning.



(Windows) You can also clean the print head using the printer driver.



Related Information

- [Clean Your Brother Machine](#)

Related Topics:

- [Clean the Print Head from Your Brother Machine](#)
 - [Clean the Print Head from Your Computer \(Windows\)](#)
 - [Access Web Based Management](#)
-

Clean the Print Head from Your Computer (Windows)

To maintain good print quality, the machine automatically cleans the print head when needed. If there is a print quality problem, start the cleaning process manually.

1. Do one of the following:

- Windows 11

Click  > **All apps** > **Windows Tools** > **Control Panel**. In the **Hardware and Sound** group, click **View devices and printers**.

- For Windows 10

Click  > **Windows System** > **Control Panel**. In the **Hardware and Sound** group, click **View devices and printers**.

2. Right-click your model's icon, and then select **Printing preferences**. If printer driver options appear, select your printer driver.

The printer driver dialog box appears.

3. Click the **Maintenance** tab.

4. Select one of the following options:

| Option | Description |
|-------------------------------|---|
| Check Print Quality... | Use to print the test page and check the print quality. |
| Print Head Cleaning... | Use to start the cleaning process manually. Select if a line or blank spaces appear in text or graphics on the test page. |

5. Do one of the following:

- If you selected the **Check Print Quality...** option, click **Start**.

The machine prints the test page.

- If you selected the **Print Head Cleaning...** option, select the **Black only**, **Color only**, or **All** option for the cleaning type, and then click **Next**.

6. Select the **Normal**, **Strong**, or **Strongest** option for the cleaning strength, and then click **Next**.

7. Click **Start**.

The machine starts cleaning.



Related Information

- [Clean Your Brother Machine](#)

Related Topics:

- [Paper Handling and Printing Problems](#)
 - [Clean the Print Head from Your Brother Machine](#)
 - [Clean the Print Head Using Web Based Management](#)
-

Clean the Machine's LCD

IMPORTANT

DO NOT use liquid cleaners (including ethanol).

1. Press and hold down  to turn off the machine. The LCD displays [Shutting Down] for a few seconds before the power goes off.
2. Clean the LCD with a dry, soft lint-free cloth.

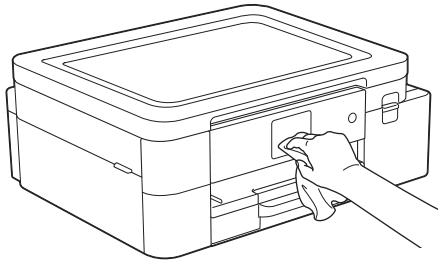

Related Information

- [Clean Your Brother Machine](#)

Clean the Outside of the Machine

IMPORTANT

- Cleaning with volatile liquids such as thinner or benzine will damage the outside surface of the machine.
- DO NOT use cleaning materials that contain ammonia.
- DO NOT use isopropyl alcohol to remove dirt from the control panel. It may crack the panel.

1. If the paper support flap is open, close it, and then close the paper support.
2. Pull the paper tray (1) completely out of the machine.

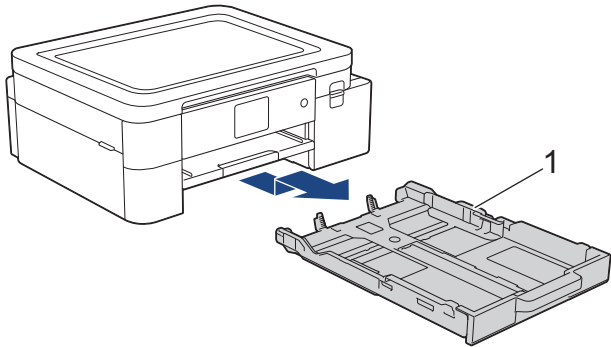

3. Lift the paper support (1), and then pull it at an angle completely out of the machine as shown by the arrow.

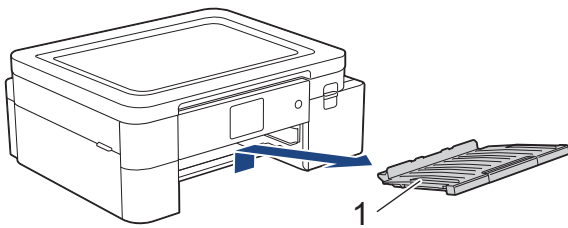

4. Wipe the outside of the machine with a dry, lint-free cloth to remove dust.

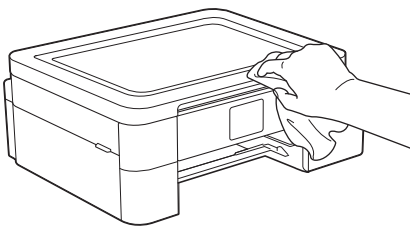

5. Wipe the inside and the outside of the paper tray with a dry, lint-free cloth to remove dust.

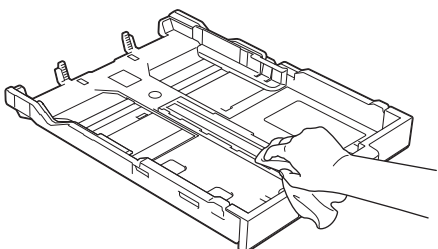

6. Wipe the outside of the paper support with a dry, lint-free cloth to remove dust.

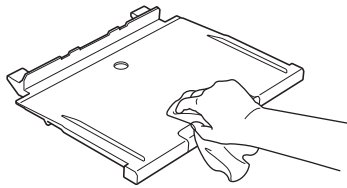

7. Put the paper support firmly back in the machine. Make sure you fit the paper support into the channels.

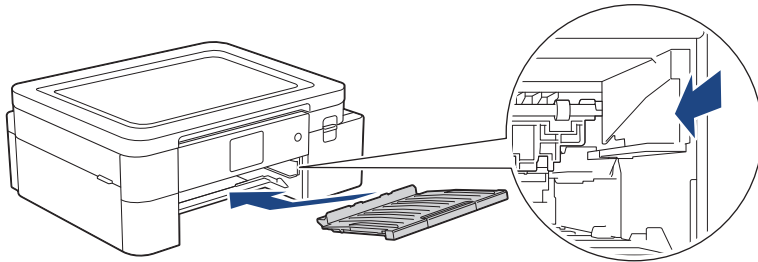

8. Slowly push the paper tray completely into the machine.

Related Information

- [Clean Your Brother Machine](#)

Clean the Machine's Printer Platen

WARNING

 Be sure to unplug the machine from the AC power outlet before cleaning the printer platen to avoid an electrical shock.

1. Using both hands, use the finger holds on each side of the machine to lift the top cover into the open position.
2. Clean the machine's printer platen (1) and the area around it, wiping off scattered ink with a dry, soft lint-free cloth.

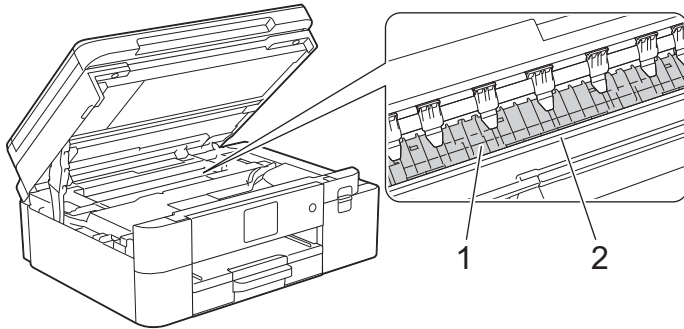

IMPORTANT

DO NOT touch the encoder strip, the thin strip of plastic that stretches across the width of the machine (2). Doing this may cause damage to the machine.

3. Gently close the top cover using both hands.

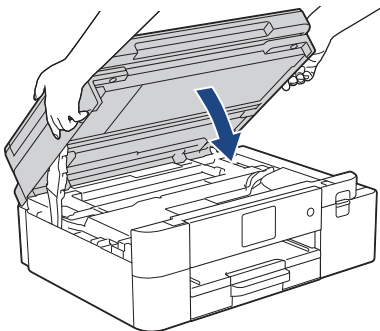

4. Reconnect the power cord.

Related Information

- [Clean Your Brother Machine](#)

Related Topics:

- [Paper Handling and Printing Problems](#)

Clean the Paper Feed Rollers

If the paper feed rollers are stained with ink or have a buildup of paper dust, it may cause paper feed problems.

1. Unplug the machine from the AC power outlet.
2. If the paper support flap is open, close it, and then close the paper support.
3. Pull the paper tray (1) completely out of the machine.

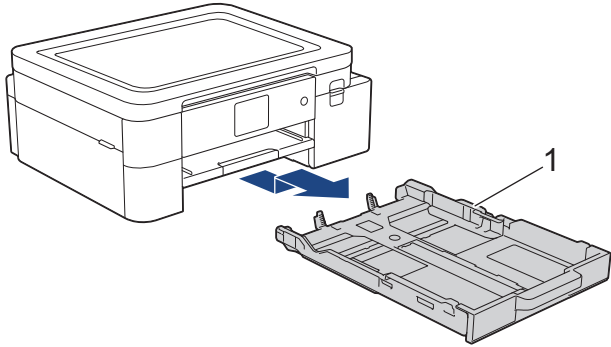

4. Lift the paper support (1), and then pull it at an angle completely out of the machine as shown by the arrow.

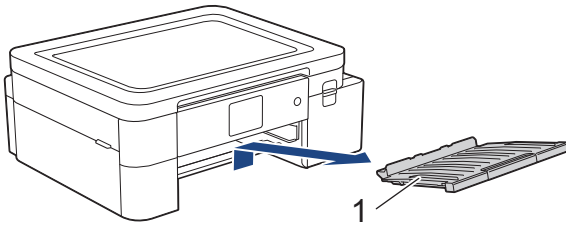

5. Clean the front side of the Paper Feed Rollers (1) with a soft lint-free cloth moistened with water, using a side-to-side motion. After cleaning, wipe the rollers with a dry, soft lint-free cloth to remove all moisture.

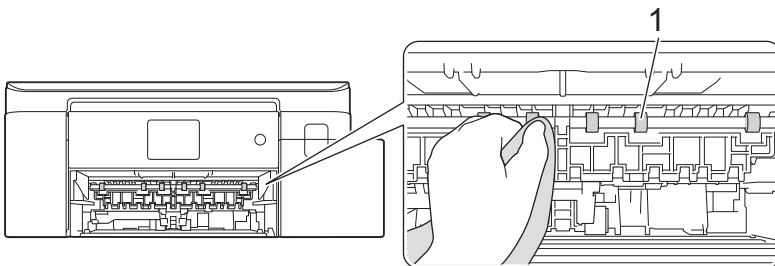

6. Put the paper support firmly back in the machine. Make sure you fit the paper support into the channels.

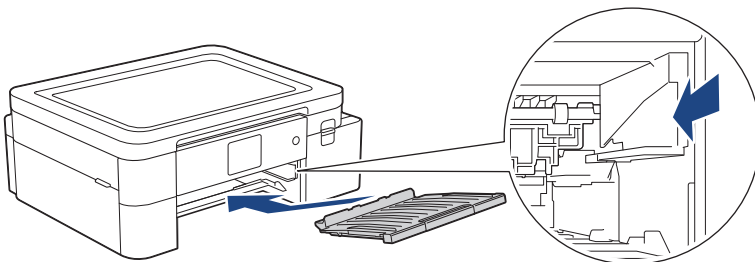

7. Slowly push the paper tray completely into the machine.
8. Reconnect the power cord.



Do not use the machine again until the rollers are dry. Using the machine before the rollers are dry may cause paper feed problems.



Related Information

- [Clean Your Brother Machine](#)

Related Topics:

- [Paper Handling and Printing Problems](#)
-

Clean the Base Pad

Cleaning the Base Pad periodically may prevent the machine from feeding multiple sheets of paper when there are only a few sheets of paper left in the tray.

1. If the paper support flap is open, close it, and then close the paper support.
2. Pull the paper tray (1) completely out of the machine.

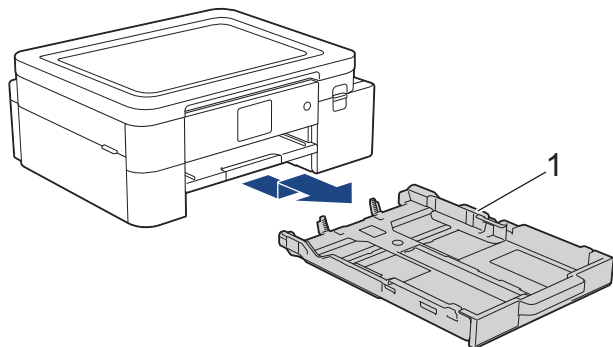

3. Clean the Base Pad (1) with a soft lint-free cloth moistened with water.
After cleaning, wipe the pad with a dry, soft lint-free cloth to remove all moisture.

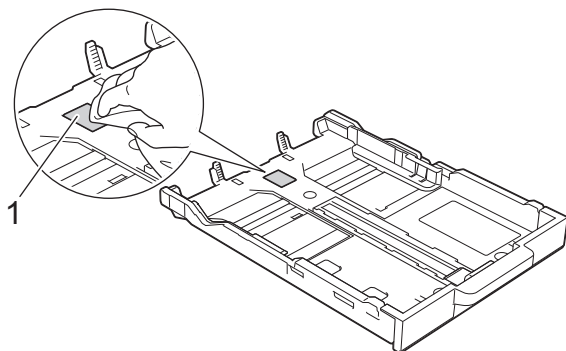

4. Slowly push the paper tray completely into the machine.

Related Information

- [Clean Your Brother Machine](#)

Related Topics:

- [Paper Handling and Printing Problems](#)
-

Clean the Paper Pick-up Rollers

Cleaning the paper pick-up rollers periodically may prevent paper jams by ensuring that paper feeds correctly.

1. Unplug the machine from the AC power outlet.
2. If the paper support flap is open, close it, and then close the paper support.
3. Pull Tray #1 (1) completely out of the machine as shown by the arrow.

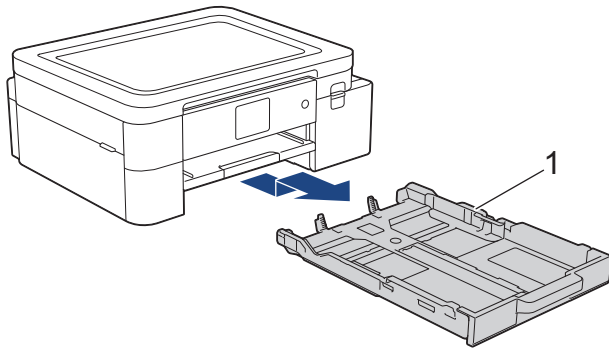

4. Lift the paper support (1), and then pull it at an angle completely out of the machine as shown by the arrow.

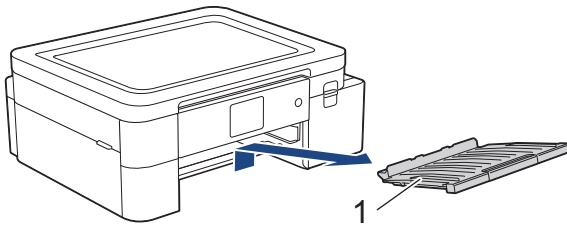

5. Clean the Paper Pick-up Rollers (1) with a soft lint-free cloth moistened with water. Slowly turn the rollers so that the whole surface is cleaned. After cleaning, wipe the rollers with a dry, soft lint-free cloth to remove all moisture.

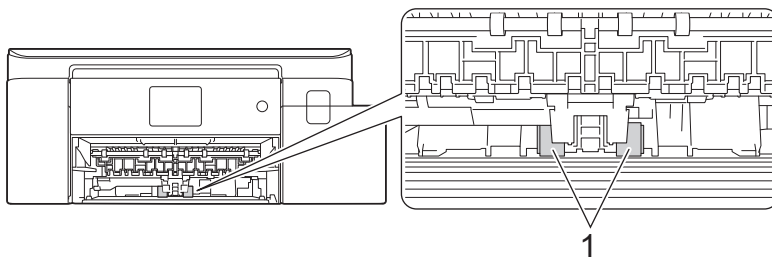

6. Put the paper support firmly back in the machine. Make sure you fit the paper support into the channels.

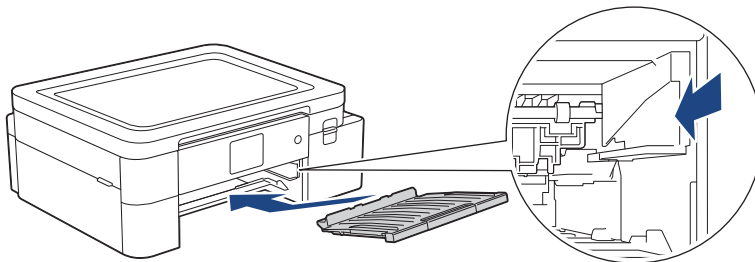

7. Slowly push the paper tray completely into the machine.
8. Reconnect the power cord.



Related Information

- [Clean Your Brother Machine](#)

Related Topics:



- [Error and Maintenance Messages](#)
 - [Paper Handling and Printing Problems](#)
-

Check Your Brother Machine

- [Check the Print Quality](#)
- [Check the Ink Volume](#)
- [Monitor Machine Status from Your Computer \(Windows\)](#)

Check the Print Quality

If faded or streaked colors and text appear or if text is missing on your printouts, the print head nozzles may be clogged. Print the check sheet and look at the nozzle check pattern.

1. Press  [Ink] > [Improve Print Quality] > [Check Print Quality].
2. Press [Start].
The machine prints the check sheet.
3. Check the quality of the four color blocks on the sheet.
4. When an LCD message prompts you to check the print quality, do one of the following:
 - If all lines are clear and visible, press [No], and then press  to finish the Print Quality check.
 - If lines are missing (see **Poor**, as follows), press [Yes].

OK

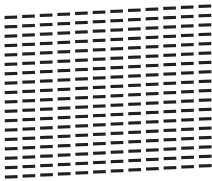

Poor

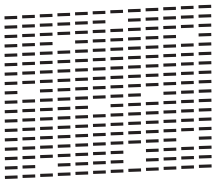

5. When the LCD message prompts you to check the print quality of each color, press the number of the pattern (1–4) that most closely matches the printing result.
6. Do one of the following:
 - If print head cleaning is needed, press [Start] to start the cleaning procedure.
 - If print head cleaning is not needed, the menu screen reappears on the touchscreen. Press .
7. After the cleaning procedure is finished, the LCD message prompts you to print the check sheet again. Press [Yes], and then press [Start].

The machine prints the check sheet again. Check the quality of the four color blocks on the sheet again.

If you clean the print head several times and the print has not improved, try the Special cleaning method. See *Related Information*.

IMPORTANT

DO NOT touch the print head. Touching the print head may cause permanent damage and may void the print head's warranty.



When a print head nozzle is clogged, the printed sample looks like this:



After the print head nozzle is cleaned, the lines are gone:



Related Information

- [Check Your Brother Machine](#)

Related Topics:

- [Paper Handling and Printing Problems](#)
 - [Clean the Print Head from Your Brother Machine](#)
-

Check the Ink Volume

Although an ink volume icon appears on the machine's LCD, you can view a larger graph that displays the approximate ink remaining in each cartridge.

1. Press  [Ink] > [Ink Volume].

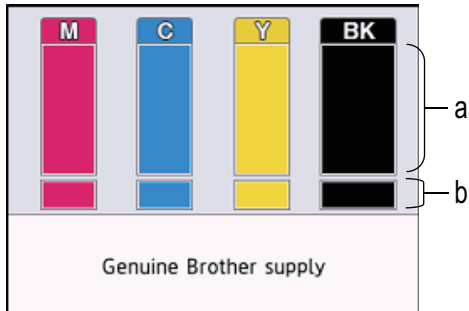

The touchscreen displays the ink volume.



- a. Displays the cartridge ink level.
- b. Displays the ink level remaining in the internal ink reservoir.



- When the ink cartridge is near the end of its life or having a problem, one of the following icons appears:

| | |
|---|--|
|  | The ink level is low. |
|  | The ink cartridge needs to be replaced. |
|  | There is a problem with the ink cartridge. |

- To check or print the ink cartridge model numbers, press  (Back) to return to the [Ink] menu screen. Press [Ink Cartridge Model], and follow the instructions on the touchscreen.

2. Press .



You can also check the ink volume from your computer.

Related Information

- [Check Your Brother Machine](#)



Related Topics:

- [Touchscreen LCD Overview](#)
- [Settings Screen Overview](#)
- [Print a Document \(Windows\)](#)
- [Monitor Machine Status from Your Computer \(Windows\)](#)

Monitor Machine Status from Your Computer (Windows)

The Status Monitor utility is a configurable software tool for monitoring the status of one or more machines; it allows you to get immediate notification of errors.

Do one of the following:

- Double-click the  icon in the task tray.
- Launch  (**Brother Utilities**), and then click the drop-down list and select your model name (if not already selected). Click **Tools** in the left navigation bar, and then click **Status Monitor**.

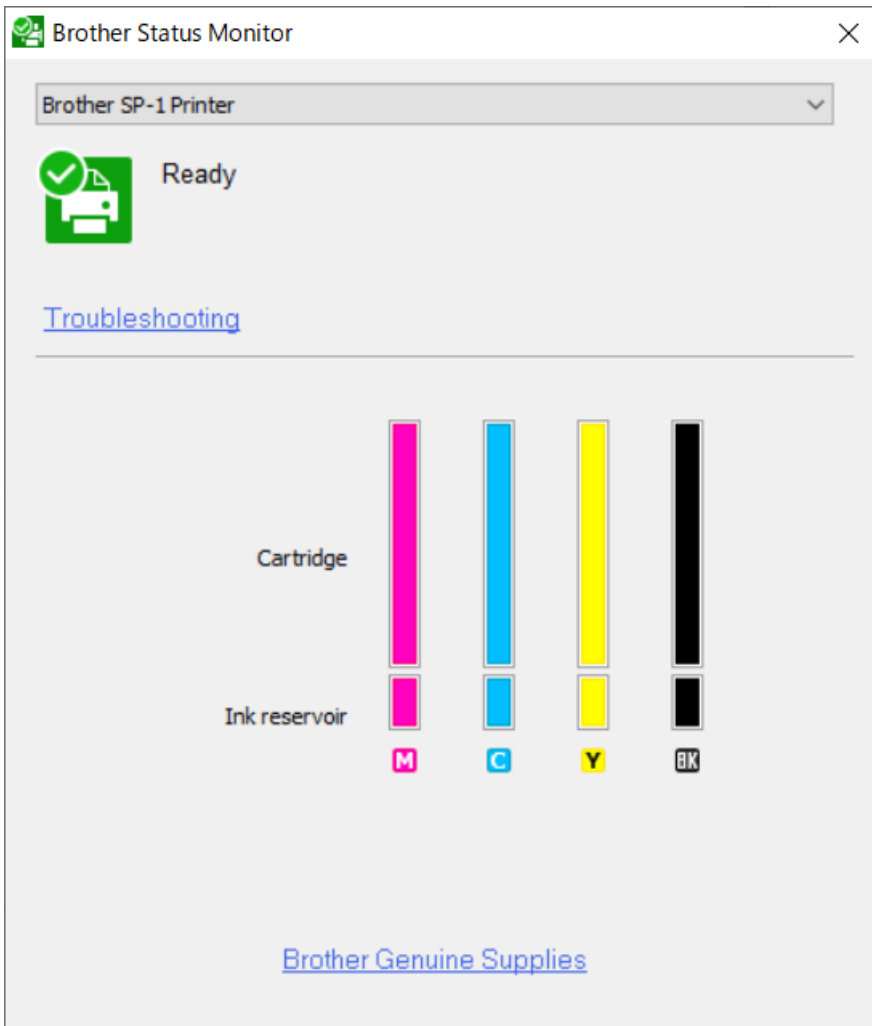



Troubleshooting

Click **Troubleshooting** to access the troubleshooting website.

Brother Genuine Supplies

Click **Brother Genuine Supplies** for more information on Brother genuine supplies.

Error icons

| Icon | Description |
|---|--|
|  | The ink level is low. |
|  | The ink cartridge needs to be replaced. |
|  | There is a problem with the ink cartridge. |



You can also check the ink amount using Web Based Management.



Related Information

- [Check Your Brother Machine](#)
 - [Status Monitor Indicators and What They Mean \(Windows\)](#)
 - [Turn Off the Show Status Monitor Feature \(Windows\)](#)
 - [Turn Off the Status Monitor \(Windows\)](#)

Related Topics:

- [Cancel a Print Job \(Windows\)](#)
 - [Check the Ink Volume](#)
-

Status Monitor Indicators and What They Mean (Windows)

When you start up your computer, the **Brother Status Monitor** icon appears on the task tray.

- A green icon indicates the normal stand-by condition.



- A yellow icon indicates a warning.



- A red icon indicates an error has occurred.



- A gray icon indicates the machine is offline.



✓ Related Information

- [Monitor Machine Status from Your Computer \(Windows\)](#)
-

Turn Off the Show Status Monitor Feature (Windows)

The Show Status Monitor feature lets you know if there is a problem with a device that your computer is monitoring. The default setting is **Only when printing from this PC**. To turn it off, follow these steps:

1. Right-click the  (**Brother Status Monitor**) icon or window, select the **Status Monitor Settings** option, and then click **Options**.
The **Options** window appears.
2. Click the **Show Status Monitor** tab, and then select **Off** for **Status Monitor Display Options**.
3. Click **OK**.



Even if the Show Status Monitor feature is turned off, you can check the machine's status at any time by displaying the Status Monitor.



Related Information

- [Monitor Machine Status from Your Computer \(Windows\)](#)
-

Turn Off the Status Monitor (Windows)

1. Right-click the  (Brother Status Monitor) icon or window, and then select **Exit**.
2. Click **OK**.

Related Information

- [Monitor Machine Status from Your Computer \(Windows\)](#)
-

Correct the Paper Feed to Clear Vertical Lines

Adjust the paper feed to reduce vertical lines.

Before adjusting the paper feed, make a print quality check first by pressing  [Ink] > [Improve Print Quality] > [Check Print Quality].

1. Press  [Ink] > [Improve Print Quality] > [Correct Paper Feed].
2. Press [Next].
3. Press [Yes] after a confirmation message if a print quality check has been completed appears on the LCD.
4. Load specified size paper in the tray, and then press [Start].
The machine prints the check sheet.
5. Follow the instructions on the LCD.

Related Information

- [Routine Maintenance](#)

Related Topics:

- [Paper Handling and Printing Problems](#)
 - [Other Problems](#)
-

Change the Print Options to Improve Your Print Results

If your printouts do not look the way you expect, change the print settings on your Brother machine to improve printout quality. Print speed may be slower when using these settings.



- These instructions allow you to improve your print results when you are using your machine for copying, printing from media, or a mobile device.
- If you are experiencing poor print quality when printing from your computer, change your printer driver settings.

1. Press  [Ink] > [Print Options].
2. Press one of the following options:

| Option | Description |
|-----------------|---|
| Reduce Smudging | Select this option if you have problems with smudged printouts or paper jams. |

3. Follow the LCD menus.
4. Press .



Related Information

- [Routine Maintenance](#)

Related Topics:

- [Paper Handling and Printing Problems](#)
 - [Other Problems](#)
 - [Prevent Smudged Printouts and Paper Jams \(Windows\)](#)
 - [Print Settings \(Windows\)](#)
-

Pack and Ship Your Machine

- When you transport the machine, use the packing materials that came with your machine. Do not tip or turn the product upside down. If you do not pack the machine correctly, any damage that may occur in transit may not be covered by your warranty.
- The machine should be adequately insured with the carrier.

IMPORTANT

It is important to allow the machine to “park” the print head after a print job. Listen carefully to the machine before unplugging it to make sure that all mechanical noises have stopped. Not allowing the machine to finish this parking process may lead to print problems and possible damage to the print head.

1. Unplug the machine from the AC power outlet.
2. Using both hands, use the finger holds on each side of the machine to lift the top cover into the open position.
3. Unplug the interface cable from the machine, if it is connected.
4. Gently close the top cover using the finger holds on each side.

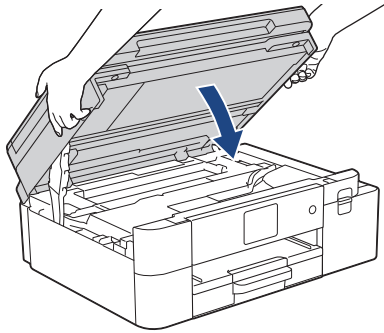

5. Open the ink cartridge cover.
6. Press the ink release levers to release the ink cartridges and then take out the ink cartridges.

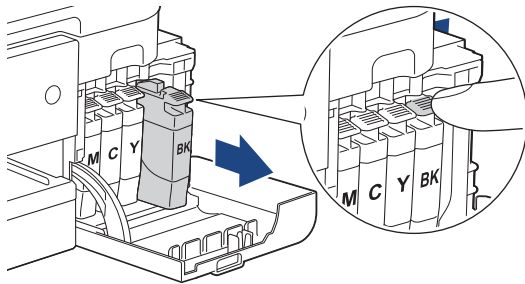

7. Wrap the machine in the bag.

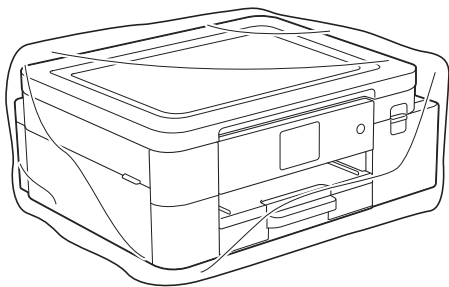

-
8. Pack the machine in the original carton with the original packing material as shown below.
Do not pack the used ink cartridge in the carton.

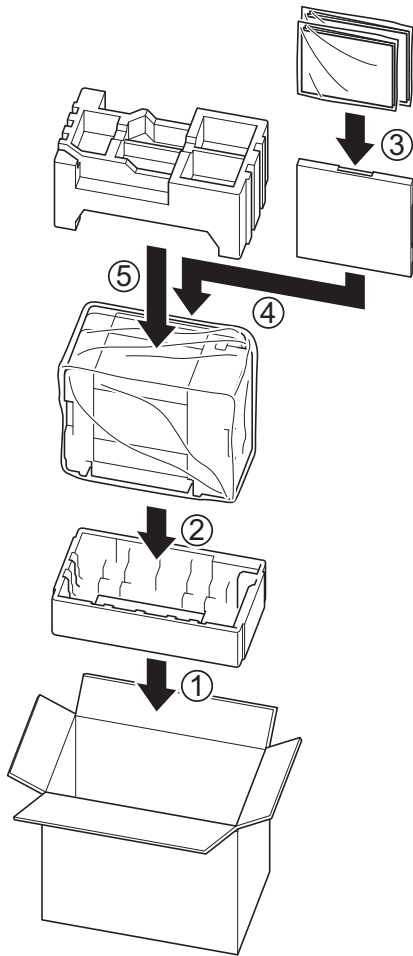

If you are returning your machine to Brother as part of the Exchange Service, pack only the machine. Keep all separate parts and printed materials to use with your “Exchange” machine.

9. Close the carton and tape it shut.

Related Information

- [Routine Maintenance](#)

Related Topics:

- [Disposing of Used Consumables](#)
 - [Replace the Ink Cartridges](#)
-

Machine Settings

Customize settings and features to make your machine a more efficient work tool.

- [Change Machine Settings from the Control Panel](#)
- [Change Machine Settings Using Web Based Management](#)

Change Machine Settings from the Control Panel

- [In the Event of Power Failure \(Memory Storage\)](#)
- [General Settings](#)
- [Print Reports](#)
- [Settings and Features Tables](#)

In the Event of Power Failure (Memory Storage)

- Your menu settings are stored permanently and will not be lost.
- Temporary settings are lost.
- The date and time is retained for approximately 24 hours.





Related Information

- [Change Machine Settings from the Control Panel](#)
-

General Settings

- [Adjust the Machine Volume](#)
- [Change for Daylight Saving Time Automatically](#)
- [Set Sleep Mode Countdown](#)
- [Set the Machine to Power Off Automatically](#)
- [Set the Date and Time](#)
- [Set the Time Zone](#)
- [Adjust the LCD Backlight Brightness](#)
- [Change How Long the LCD Backlight Stays On](#)
- [Change the Language Displayed on the LCD](#)
- [Change the Keyboard Setting](#)

Adjust the Machine Volume

1. Press  [Settings] > [Beep].
2. Press ▲ or ▼ to display the [Off], [Low], [Med], or [High] option, and then press the option you want.
3. Press .

Related Information



- [General Settings](#)
-

Change for Daylight Saving Time Automatically

You can program the machine to change automatically for Daylight Saving Time.

It will reset itself forward one hour in the spring, and backward one hour in the fall. Make sure you have set the correct date and time in the [Date & Time] setting.

This feature is available only in the USA and Canada.

1. Press  [Settings].
2. Press  [Date & Time] > [Auto Daylight].
3. Press [On] or [Off].
4. Press .



Related Information

- [General Settings](#)

Set Sleep Mode Countdown

The Sleep Mode (or Power Save Mode) setting can reduce power consumption. When the machine is in Sleep Mode, it acts as though it is turned off. The machine will wake up and start printing when it receives a print job. Use these instructions to set a time delay (countdown) before the machine enters Sleep Mode.

- The timer will restart if any operation is carried out on the machine, such as a print job.
- The factory setting is five minutes.

1. Press  [Settings] > [All Settings] > [General Setup] > [Sleep Time].
2. Enter the number of minutes (1-60) you want to set on the touchscreen, and then press [OK].
3. Press .



When the machine goes into Sleep Mode, the LCD backlight turns off.



Related Information

- [General Settings](#)

Related Topics:

- [Set the Machine to Power Off Automatically](#)
-

Set the Machine to Power Off Automatically



The Auto Power Off feature can reduce power consumption. Set the amount of time that the machine must be in Sleep Mode before it automatically powers off. When this feature is set to [Off], you must power off the machine manually.

To turn on the machine after the Auto Power Off feature has turned it Off, press .



The machine does not power off automatically when:

- The machine is connected to a wired network.
 - The machine is connected to a wireless network.
 - [WLAN Enable] is set to [On] or [WLAN (Wi-Fi)] is selected in the [Network I/F] setting.
-

1. Press  [Settings] > [All Settings] > [General Setup] > [Auto Power Off].
2. Press ▲ or ▼ to display the [Off], [1 hour], [2 hours], [4 hours], or [8 hours] option, and then press the option you want.
3. Press .



Related Information



- [General Settings](#)

Related Topics:

- [Set Sleep Mode Countdown](#)
-

Set the Date and Time

The LCD displays the date and time. If they are not current, re-enter them.

1. Press  [Settings].
2. Press  [Date & Time].
3. Press [Date].
4. Enter the last two digits of the year on the touchscreen, and then press [OK].
5. Enter two digits for the month on the touchscreen, and then press [OK].
6. Enter two digits for the day on the touchscreen, and then press [OK].
7. Press [Clock Type].
8. Press [12h Clock] or [24h Clock].
9. Press [Time].
10. To enter the time, do one of the following:
 - If you selected [12h Clock], enter the time (in 12-hour format) using the touchscreen, and then press [AM] or [PM].
Press [OK].
 - If you selected [24h Clock], enter the time (in 24-hour format) using the touchscreen.
Press [OK].
(For example, enter 19:45 for 7:45 PM.)
11. Press .

Related Information



- [General Settings](#)
-

Set the Time Zone

Set the time zone for your location on the machine.

For example, the time zone for Eastern Time in the USA and Canada is UTC-05:00. Pacific Time in the USA and Canada is UTC-08:00.

| Time Zone | Standard Time |
|---------------------------|---------------|
| Hawaii-Aleutian Time Zone | UTC - 10:00 |
| Alaska Time Zone | UTC - 9:00 |
| Pacific Time Zone | UTC - 8:00 |
| Mountain Time Zone | UTC - 7:00 |
| Central Time Zone | UTC - 6:00 |
| Eastern Time Zone | UTC - 5:00 |
| Atlantic Time Zone | UTC - 4:00 |



1. Press  [Settings].
2. Press  [Date & Time] > [Time Zone].
3. Enter your time zone.
4. Press [OK].
5. Press .

Related Information

- [General Settings](#)
-

Adjust the LCD Backlight Brightness

If you are having difficulty reading the LCD, changing the brightness setting may help.

1. Press  [Settings] > [All Settings] > [General Setup] > [LCD Settings] > [Backlight].
2. Press the [Light], [Med], or [Dark] option.
3. Press .





Related Information

- [General Settings](#)

Change How Long the LCD Backlight Stays On

Set how long the LCD backlight stays on.

1. Press  [Settings] > [All Settings] > [General Setup] > [LCD Settings] > [Dim Timer].
2. Press ▲ or ▼ to display the [10 Secs], [30 Secs], [1 Min], [2 Mins], [3 Mins], or [5 Mins] option, and then press the option you want.
3. Press .





Related Information

- [General Settings](#)

Change the Language Displayed on the LCD

Change the LCD language if needed.

This feature is not available in some countries.



1. Press  [Settings] > [All Settings] > [Initial Setup] > [Local Language].
2. Press your language.
3. Press .

Related Information

- [General Settings](#)
-

Change the Keyboard Setting

You can choose the type of keyboard for the LCD.

1. Press  [Settings] > [All Settings] > [General Setup] > [Keyboard Settings].
2. Press [QWERTY] or [ABC].
3. Press .



Related Information

- [General Settings](#)
-

Print Reports

- [Reports](#)
- [Print a Report](#)

Reports

The following reports are available:

Network Configuration (network models)

The Network Configuration report prints a list of your current network settings.

WLAN Report (wireless models)



The WLAN Report prints the wireless LAN connectivity diagnosis.



Related Information

- [Print Reports](#)
-

Print a Report

1. Press  [Settings] > [All Settings] > [Print Reports].
2. Press the option you want.
3. Press [Yes].
4. Press .

Related Information

- [Print Reports](#)

Settings and Features Tables

- [Settings Tables \(2.7" Touchscreen models\)](#)
- [Features Tables \(2.7" Touchscreen models\)](#)

Settings Tables (2.7" Touchscreen models)

These tables will help you understand your machine's menu selections and options.

>> [Settings]

>> [General Setup]

>> [Network]

>> [Print Reports]

>> [Machine Info.]

>> [Initial Setup]

[Settings]



[Settings]

| Level 1 | Level 2 | Level 3 | Descriptions |
|--|--------------|---------|---|
|  (Date & Time) | - | - | Access the Date and Time setting menus. |
| Maintenance | - | - | Access the Maintenance settings menus. |
| Network | Wired LAN | - | Access the Wired LAN setting menus. |
| | WLAN (Wi-Fi) | - | Access the WLAN setting menus. |
| | Wi-Fi Direct | - | Access the Wi-Fi Direct setting menus. |
| | Network I/F | - | Select the network connection type. |
| Tray Setting | - | - | Access the tray setting menus. |
| Wi-Fi Direct | - | - | Access the Wi-Fi Direct setting menus. |
| Beep | - | - | Adjust the beeper volume. |
| All Settings | - | - | Configure the detailed settings. |

[General Setup]



[All Settings] > [General Setup]

| Level 3 | Level 4 | Level 5 | Descriptions |
|---------------------|-----------------------|---|---|
| Maintenance | Improve Print Quality | Check Print Quality | Check and correct the print quality, and paper feeding according to the LCD instructions. |
| | | Correct Paper Feed | |
| | Print Head Cleaning | Black only | Clean the print head according to the LCD instructions. |
| | | Color only | |
| | | All | |
| | Ink Volume | - | Check the available ink volume. |
| | Ink Cartridge Model | - | Check your ink cartridge numbers. |
| Print Options | Reduce Smudging | Reduce smudging on the paper or paper jams during printing. | |
| Ink Cartridge Check | - | View your ink cartridge information. | |
| Paper Type | - | - | Check your paper type. |
| Paper Size | - | - | Set the size of paper in the paper tray. |
| Check Paper | - | - | Check the paper type and paper size when you pull the tray out of the machine. |

| Level 3 | Level 4 | Level 5 | Descriptions |
|-------------------|-----------|---------|---|
| LCD Settings | Backlight | - | Adjust the brightness of the LCD backlight. |
| | Dim Timer | - | Set how long the LCD backlight stays on after the last finger press. |
| Keyboard Settings | - | - | Select the type of keyboard for the LCD. |
| Sleep Time | - | - | Select how long the machine must be idle before it goes into Sleep Mode. |
| Auto Power Off | - | - | Select how long the machine must wait before it automatically turns itself off after entering Sleep Mode. When set to Off, the machine does not power off automatically. |

[Network]



[All Settings] > [Network]

| Level 3 | Level 4 | Level 5 | Level 6 | Descriptions |
|-------------|--------------|--------------------|---------------------------------|---|
| Wired LAN | TCP/IP | BOOT Method | - | Select the Boot method that best suits your needs. |
| | | IP Address | - | Enter the IP address. |
| | | Subnet Mask | - | Enter the Subnet mask. |
| | | Gateway | - | Enter the Gateway address. |
| | | Node Name | - | Enter the Node name. |
| | | WINS Configuration | - | Select the WINS configuration mode. |
| | | WINS Server | - | Specify the IP address of the primary or secondary WINS server. |
| | | DNS Server | - | Specify the IP address of the primary or secondary DNS server. |
| | | APIPA | - | Set the machine to allocate the IP address from the link-local address range automatically. |
| | | IPv6 | - | Turn the IPv6 protocol on or off. |
| | Ethernet | - | - | Select the Ethernet link mode. |
| | Wired Status | - | - | View the current wired status. |
| MAC Address | - | - | View the machine's MAC address. | |

| Level 3 | Level 4 | Level 5 | Level 6 | Descriptions |
|--------------|--------------------|--------------------|--------------------------------------|---|
| WLAN (Wi-Fi) | Find Wi-Fi Network | - | - | Configure your wireless network settings manually. |
| | TCP/IP | BOOT Method | - | Select the Boot method that best suits your needs. |
| | | IP Address | - | Enter the IP address. |
| | | Subnet Mask | - | Enter the Subnet mask. |
| | | Gateway | - | Enter the Gateway address. |
| | | Node Name | - | Enter the Node name. |
| | | WINS Configuration | - | Select the WINS configuration mode. |
| | | WINS Server | - | Specify the IP address of the primary or secondary WINS server. |
| | | DNS Server | - | Specify the IP address of the primary or secondary DNS server. |
| | | APIPA | - | Set the machine to allocate the IP address from the link-local address range automatically. |
| | IPv6 | - | Turn the IPv6 protocol on or off. | |
| | WPS/Push Button | - | - | Configure your wireless network settings using the one-button push method. |
| | WPS/PIN Code | - | - | Configure your wireless network settings using WPS with a PIN. |
| | Recover WLAN | - | - | Reset and restart your wireless network. |
| | WLAN Status | Status | - | View the current wireless network status. |
| | | Signal | - | View the current wireless network signal strength. |
| | | SSID | - | View the current SSID. |
| Comm. Mode | | - | View the current Communication mode. | |
| MAC Address | - | - | View the machine's MAC address. | |

| Level 3 | Level 4 | Level 5 | Level 6 | Descriptions | |
|----------------------|--------------------|------------------|---------|---|---|
| Wi-Fi Direct | Manual | - | - | Configure your Wi-Fi Direct network settings manually. | |
| | Group Owner | - | - | Set your machine as the Group Owner. | |
| | Push Button | - | - | Configure your Wi-Fi Direct network settings using the one-button push method. | |
| | PIN Code | - | - | Configure your Wi-Fi Direct network settings using WPS with a PIN code. | |
| | Device Information | Device Name | - | - | View your machine's device name. |
| | | SSID | - | - | View the Group Owner's SSID. When the machine is not connected, the LCD displays Not Connected. |
| | | IP Address | - | - | View your machine's current IP Address. |
| | Status Information | Status | - | - | View the current Wi-Fi Direct network status. |
| | | Signal | - | - | View the current Wi-Fi Direct network signal strength. When your machine acts as Group Owner, the LCD always indicates a strong signal. |
| | I/F Enable | - | - | - | Turn the Wi-Fi Direct connection on or off. |
| Web Connect Settings | Proxy Settings | Proxy Connection | - | Change the Web connection settings. | |
| | | Address | - | | |
| | | Port | - | | |
| | | User Name | - | | |
| | | Password | - | | |
| Network I/F | - | - | - | Select the network connection type. | |
| IPsec | - | - | - | IPsec is an optional security feature of the IP protocol that provides authentication and encryption services. We recommend contacting your network administrator before changing this setting. | |
| Network Reset | - | - | - | Restore all network settings back to the factory settings. | |

[Print Reports]



[All Settings] > [Print Reports]

| Level 3 | Descriptions |
|-----------------------|--|
| Network Configuration | Print a list of your Network settings. |
| WLAN Report | Print the wireless LAN connection results. |

[Machine Info.]



[All Settings] > [Machine Info.]

| Level 3 | Level 4 | Descriptions |
|---------------------|--------------|--|
| Serial No. | - | Check your machine's serial number. |
| Firmware Version | Main Version | Check your machine's firmware version. |
| Firmware Update | - | Update your machine to the latest firmware. |
| Firmware Auto Check | - | View firmware information on the Home screen. |
| Page Counter | - | Check the total number of pages the machine has printed. |

[Initial Setup]



[All Settings] > [Initial Setup]

| Level 3 | Level 4 | Descriptions |
|---|-------------------------------------|--|
| Date & Time | Date | Add the date and time on the screen. |
| | Time | |
| | Clock Type | Select the time format (12-hour or 24-hour). |
| | Auto Daylight (USA and Canada only) | Set the machine to change automatically for Daylight Saving Time. |
| | Time Zone | Set your time zone. |
| Reset | Machine Reset | Restore all the machine's settings that you have changed, such as Date and Time. |
| | Network | Restore all network settings back to the factory settings. |
| | All Settings | Restore all the machine's settings back to the factory settings. |
| Local Language (Available only for some countries.) | - | Change your LCD language. |

Related Information

- [Settings and Features Tables](#)

Features Tables (2.7" Touchscreen models)

>>  [Download Software]

>>  [Maintenance]

>>  [Ink]

>>  Wi-Fi Setup

[Download Software]

| Level 1 | Descriptions |
|-------------------|--|
| Download Software | Displays information about downloading and installing software for mobile devices and computers. |

[Maintenance]

| Level 2 | Level 3 | Level 4 | Descriptions |
|---------------------|-----------------------|---|---|
| Maintenance | Improve Print Quality | Check Print Quality | Check and correct the print quality, and paper feeding according to the LCD instructions. |
| | | Correct Paper Feed | |
| | Print Head Cleaning | Black only | Clean the print head according to the LCD instructions. |
| | | Color only | |
| | | All | |
| | Ink Volume | - | Check the available ink volume. |
| | Ink Cartridge Model | - | Check your ink cartridge numbers. |
| Print Options | Reduce Smudging | Reduce smudging on the paper or paper jams during printing. | |
| Ink Cartridge Check | - | View your ink cartridge information. | |

[Ink]

| Level 2 | Level 3 | Descriptions |
|-----------------------|---------------------|---|
| Ink Volume | - | Check the available ink volume. |
| Ink Cartridge Model | - | Check your ink cartridge numbers. |
| Improve Print Quality | Check Print Quality | Check and correct the print quality, and paper feeding according to the LCD instructions. |
| | Correct Paper Feed | |
| Print Head Cleaning | Black only | Clean the print head according to the LCD instructions. |
| | Color only | |
| | All | |
| Print Options | Reduce Smudging | Reduce smudging on the paper or paper jams during printing. |
| Ink Cartridge Check | - | View your ink cartridge information. |



Wi-Fi Setup

| Level 2 | Descriptions |
|--------------------|--|
| Find Wi-Fi Network | Configure your wireless network settings manually. |
| WPS/Push Button | Configure your wireless network settings using the one-button push method. |
| Recover WLAN | Reset and restart your wireless network. |



Related Information

- [Settings and Features Tables](#)

Change Machine Settings Using Web Based Management

Web Based Management is a utility that uses a standard web browser to manage your machine using the Hyper Text Transfer Protocol (HTTP) or Hyper Text Transfer Protocol over Secure Socket Layer (HTTPS).

- [What is Web Based Management?](#)
- [Access Web Based Management](#)
- [Set or Change a Login Password for Web Based Management](#)

What is Web Based Management?

Web Based Management is a utility that uses a standard web browser to manage your machine using the Hyper Text Transfer Protocol (HTTP) or Hyper Text Transfer Protocol over Secure Socket Layer (HTTPS).



- We recommend using the latest version of the following web browsers:
 - Microsoft Edge, Firefox, and Google Chrome™ for Windows
 - Safari, Firefox, and Google Chrome™ for Mac
 - Google Chrome™ for Android™
 - Safari and Google Chrome™ for iOS
- Ensure that JavaScript and Cookies are always enabled, regardless of which web browser you use.

SP-1

brother

Status

Device Status

Ready

Automatic Refresh

Off
 On

Estimated Ink Level

Cartridge

Internal Ink Reservoir

M C Y BK

Web Language

Auto

Device Location

Contact :

Location :

The actual screen may differ from the screen shown above.



Related Information

- [Change Machine Settings Using Web Based Management](#)

Access Web Based Management

- We recommend using the latest version of the following web browsers:
 - Microsoft Edge, Firefox, and Google Chrome™ for Windows
 - Safari, Firefox, and Google Chrome™ for Mac
 - Google Chrome™ for Android™
 - Safari and Google Chrome™ for iOS
- Ensure that JavaScript and Cookies are always enabled, regardless of which web browser you use.
- The default password to manage this machine's settings is located on the back of the machine and marked "Pwd". We recommend immediately changing the default password to protect your machine from unauthorized access. You can also find the default password in the Network Configuration Report.
- If the password is entered incorrectly several times, you will not be able to log in for a while. The lockout settings can be changed in Web Based Management.
- Up to eight computers or mobile devices can be logged in to Web Based Management at the same time. If you log in a ninth device, the first device will be logged out.
- We recommend using the HTTPS security protocol when configuring settings using Web Based Management. If you use HTTP when configuring settings using Web Based Management, follow the screen prompts to switch to a secure HTTPS connection.
- When you use HTTPS for Web Based Management configuration, your browser will display a warning dialog box. To avoid displaying the warning dialog box, you can install a self-signed certificate to use SSL/TLS communication. For more detailed information, see *Related Information*.

>> [Start from Your Web Browser](#)

>> [Start from Brother Utilities \(Windows\)](#)

Start from Your Web Browser

1. Start your web browser.
2. Type "https://machine's IP address" in your browser's address bar (where "machine's IP address" is the machine's IP address).

For example:

https://192.168.1.2



If you are using a Domain Name System or enable a NetBIOS name, you can type another name, such as "SharedPrinter" instead of the IP address.

For example:



https://SharedPrinter

If you enable a NetBIOS name, you can also use the node name.

For example:

https://brn123456abcdef



The NetBIOS name can be found in the Network Configuration Report.

3. If required, type the password in the **Login** field, and then click **Login**.
4. If you want to pin the navigation menu on the left side of the screen, click  and then click .

You can now change the machine settings.

Start from Brother Utilities (Windows)

1. Launch  (**Brother Utilities**), and then click the drop-down list and select your model name (if not already selected).
2. Click **Tools** in the left navigation bar, and then click **Machine Settings**.
Web Based Management appears.

-
3. If required, type the password in the **Login** field, and then click **Login**.
 4. If you want to pin the navigation menu on the left side of the screen, click  and then click .
- You can now change the machine settings.



Related Information

- [Change Machine Settings Using Web Based Management](#)

Related Topics:

- [Print the Network Configuration Report](#)
 - [Create a Self-signed Certificate](#)
 - [Install the Self-signed Certificate for Windows Users as Administrators](#)
-

Set or Change a Login Password for Web Based Management

The default password to manage this machine's settings is located on the back of the machine and marked "**Pwd**". We recommend immediately changing the default password to protect your machine from unauthorized access.

1. Start your web browser.
2. Type "https://machine's IP address" in your browser's address bar (where "machine's IP address" is the machine's IP address).

For example:

https://192.168.1.2



If you are using a Domain Name System or enable a NetBIOS name, you can type another name, such as "SharedPrinter" instead of the IP address.

For example:

https://SharedPrinter

If you enable a NetBIOS name, you can also use the node name.

For example:

https://brn123456abcdef

The NetBIOS name can be found in the Network Configuration Report.

-
3. Do one of the following:
 - If you have previously set your own password, type it, and then click **Login**.
 - If you have not previously set your own password, type the default login password, and then click **Login**.
 4. Go to the navigation menu, and then click **Administrator > Login Password**.



Start from , if the navigation menu is not shown on the left side of the screen.

-
5. Following the on-screen **Login Password** guidelines, type your password in the **Enter New Password** field.
 6. Retype the password in the **Confirm New Password** field.
 7. Click **Submit**.



You can also change the lockout settings in the **Login Password** menu.



Related Information

- [Change Machine Settings Using Web Based Management](#)

Related Topics:

- [Access Web Based Management](#)
-

Appendix

- [Specifications](#)
- [Supply Specifications](#)
- [Brother Help and Customer Support](#)

Specifications

- >> [General Specifications](#)
- >> [Print Media Specifications](#)
- >> [Printer Specifications](#)
- >> [Interface Specifications](#)
- >> [Network Specifications](#)
- >> [Computer Requirements Specifications](#)

General Specifications

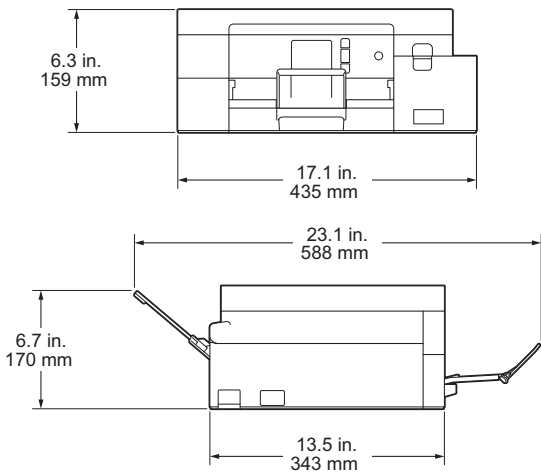
| | | |
|--|------------------|--|
| Printer Type | | Inkjet |
| Print Head | Black | Piezo with 210 nozzles x 1 |
| | Color | Piezo with 210 nozzles x 3 |
| Memory Capacity | | 128 MB |
| Liquid Crystal Display (LCD) ¹ | | 2.7 in. (67.5 mm) TFT Color Touchscreen LCD |
| Power Source | | AC 100 to 120 V 50/60 Hz |
| Power Consumption ² | | Printing ³ : Approx. 10 W Ready ⁴ : Approx. 3 W Sleep ⁴ : Approx. 0.9 W Power Off ^{4 5} : Approx. 0.2 W |
| Dimensions | |  |
| Weights | | 17.4 lb (7.9 kg) |
| Temperature | Operating | 50 °F to 95 °F (10°C to 35°C) |
| Humidity | Operating | 20 to 80% (without condensation) |

¹ Measured diagonally

² Measured when the machine is connected to the USB interface. Power consumption varies slightly depending on the usage environment or part wear.

³ When printing single-sided, resolution: standard / document: ISO/IEC 24712 printed pattern.

⁴ Measured according to IEC 62301 Edition 2.0.

⁵ Even when the machine is turned off, it will automatically turn itself on periodically for print head maintenance, and then turn itself off again.

Print Media Specifications

| | | | |
|-----------------------------|------------------|---|--|
| Paper Input | Paper Tray | Paper Type ¹ | Sublimation Paper |
| | | Paper Size | Letter, A4, Legal ³ |
| | | Maximum Paper Capacity | Up to 100 sheets of Brother Sublimation Paper (SP01PL) |
| | Manual Feed Slot | Paper Type ¹ | Sublimation Paper |
| | | Paper Size | Letter, A4, Legal ³ |
| | | Maximum Paper Capacity | Up to 1 sheet |
| Paper Output ^{1 2} | | Up to 20 sheets of Brother Sublimation Paper (SP01PL) (face up print delivery to the output paper tray) | |

1 Remove any printed pages from the output paper tray immediately to avoid smudging.

2 Actual output tray capacity may vary depending on environmental conditions.

3 For Brother Sublimation Paper information, go to your model's **Consumables & Accessories** page at <https://s.brother.com/2ab/>.

Printer Specifications

| | |
|-----------------------------|--|
| Resolution | Up to 1200 × 2400 dpi |
| Printing Width ¹ | 8.26 in. (210 mm) |
| Print Speed | See your model's page on your local Brother website. |

1 When printing on Letter size paper.

Interface Specifications

| | |
|--------------------|--|
| USB ^{1 2} | Use a USB 2.0 interface cable that is no longer than 6 feet (2 m). |
| LAN | Use an Ethernet UTP cable category 5 or greater. |
| Wireless LAN | IEEE 802.11b/g/n (Infrastructure) IEEE 802.11g/n (Wi-Fi Direct) |

1 Your machine has a USB 2.0 Hi-Speed interface. The machine can also be connected to a computer that has a USB 1.1 interface.

2 Third party USB ports are not supported.

Network Specifications



You can connect your machine to a network for Network Printing.

| | | |
|--------------------------------|-----|---|
| Network Security (Wired) | | SMTP-AUTH, SSL/TLS (IPPS, HTTPS, SMTP), SNMP v3, 802.1x (EAP-MD5, EAP-FAST, PEAP, EAP-TLS, EAP-TTLS), IPsec |
| Network Security (Wireless) | | SMTP-AUTH, SSL/TLS (IPPS, HTTPS, SMTP), SNMP v3, 802.1x (EAP-FAST, PEAP, EAP-TLS, EAP-TTLS), Ipsec |
| Wireless Network Security | | SSID (32 characters), WEP 64/128 bit, WPA-PSK (TKIP/AES), WPA2- PSK (TKIP/AES) |
| Wireless Setup Support Utility | WPS | Yes |

Computer Requirements Specifications

Supported Operating Systems and Software Functions

| Computer Platform & Operating System Version | | PC Interface | | | Processor | Hard Disk Space to Install ¹ | | | | | | | | |
|--|-----------------------------------|------------------|-----------|--------------|--|---|--------------------------------------|-------------------------------------|----------|--|--|------------------|-----|--------|
| | | USB ² | Wired LAN | WLAN (Wi-Fi) | | For Drivers | For Applications (Including Drivers) | | | | | | | |
| Windows Operating System | Windows 10 Home | Printing | | | 32 bit (x86) or 64 bit (x64) processor | 300 MB | 600 MB | | | | | | | |
| | Windows 10 Pro | | | | | | | | | | | | | |
| | Windows 10 Education | | | | | | | | | | | | | |
| | Windows 10 Enterprise | | | | | | | | | | | | | |
| | Windows 11 Home | | | | | | | | | | | | | |
| | Windows 11 Pro | | | | | | | | | | | | | |
| | Windows 11 Education | | | | | | | | | | | | | |
| | Windows 11 Enterprise | | | | | | | | | | | | | |
| | Mac Operating System ³ | | | | | | | macOS v11 macOS v12 macOS v13 | Printing | | | 64 bit processor | N/A | 100 MB |

¹ An Internet connection is required to install the software.

² Third party USB ports are not supported.

³ macOS Disclaimer

AirPrint capable: Printing via macOS requires the use of AirPrint. Mac drivers are not provided for this machine.

For the latest driver updates, go to your model's **Downloads** page at <https://s.brother/ca2ab/>.

All trademarks, brands, and product names are the property of their respective companies.

Related Information

- [Appendix](#)

Supply Specifications

| | |
|--------------------------------------|--|
| Sublimation Ink | The machine uses individual Black, Yellow, Cyan, and Magenta ink cartridges that are separate from the print head assembly. |
| Service Life of Ink Cartridge | The first time you install the ink cartridges, the machine will use extra ink to fill the ink delivery tubes. This is a one-time process that enables high-quality printing. |
| Replacement Supplies | <Black> SP01BK <Yellow> SP01Y <Cyan> SP01C <Magenta> SP01M |

CAUTION

- Black Sublimation Ink may cause an allergic reaction.
- Wear a protective gloves when there is a possibility of touching the ink, such as when replacing the ink cartridges, clearing paper jams or performing routine maintenance inside the product.
- If the ink accidentally gets on your skin, wash immediately with soap and cold water. If skin irritation or rash occurs, seek medical attention immediately.

Related Information

- [Appendix](#)

Brother Help and Customer Support

IMPORTANT

For technical help, you must call the country where you bought the machine. Calls must be made **from within** that country.

>> [FAQs \(Frequently Asked Questions\)](#)

>> [For Customer Service](#)

>> [Ordering Accessories and Supplies](#)

FAQs (Frequently Asked Questions)

For more information on your Brother machine, visit the Brother support website at <https://s.brother/cp2ab/>. For additional help and tips, go to your model's **FAQs & Troubleshooting** page; for the latest drivers and software, go to your model's **Downloads** page.

For Customer Service

In USA:

www.brother-usa.com/support (Self-Service/Email/Chat)

1-877-BROTHER (1-877-276-8437)

In Canada:

www.brother.ca/support

(Self-Service Videos, Email, Chat, Facebook and Twitter Help)

Service Center Locator (USA only)

For the location of a Brother authorized service center, call 1-877-BROTHER (1-877-276-8437) or visit www.brother-usa.com/support.

Service Center Locations (Canada only)

For the location of a Brother authorized service center, visit www.brother.ca/support.

Ordering Accessories and Supplies

We recommend Genuine Brother supplies, which are available at most Brother retailers. If you cannot find the supplies you need and have a Visa, MasterCard, Discover, American Express credit card, or PayPal account, you can order directly from Brother. Visit us online for a complete selection of the Brother accessories and supplies that are available for purchase.

NOTE

In Canada, only Visa and MasterCard are accepted.

In USA:

1-877-BROTHER (1-877-276-8437)

www.brother-usa.com/support

In Canada:

www.brother.ca



Related Information

- [Appendix](#)
-

Brother International Corporation
200 Crossing Boulevard
P.O. Box 6911
Bridgewater, NJ 08807-0911 USA

Brother International Corporation (Canada) Ltd.
1 rue Hôtel de Ville,
Dollard-des-Ormeaux, QC, Canada H9B 3H6

brother



USA
Version 0