

©Copyright 2011 BROTHER INDUSTRIES, LTD.

ESC/P Command Reference

Version 1.03

Model Name: PT-9800PCN/PT-9700PC

Created by: Brother Industries, Ltd.

Machine Model: PT-9800PCN/PT-9700PC

IMPORTANT - PLEASE READ CAREFULLY

This documentation ("Documentation") gives you information that will assist you in controlling your Machine Model.

You may use the Documentation only if you first agree to the following conditions.

If you do not agree to the following conditions, you may not use the Documentation.

Condition of Use

You may use and reproduce the Documentation to the extent necessary for your own use of your Machine Model ("Purpose"). Unless expressly permitted in the Documentation, you may not;

- (i) copy or reproduce the Documentation for any purpose other than the Purpose,
- (ii) modify, translate or adapt the Documentation, and/or redistribution to any third party,
- (iii) rent or lease the Documentation to any third party, or,
- (iv) remove or alter any copyright notices or proprietary rights legends included within the Documentation.

No Warranty

- a. Any updates, upgrades or alteration of the Documentation or Machine Model will be performed at the sole discretion of Brother. Brother may not respond to any request or inquiry about the Documentation.
- b. THIS DOCUMENTATION IS PROVIDED TO YOU "AS IS" WITHOUT WARRANTY OF ANY KIND, WHETHER EXPRESS OR IMPLIED, INCLUDING, BUT NOT LIMITED TO, THE IMPLIED WARRANTY OF FITNESS FOR A PARTICULAR PURPOSE. BROTHER DOES NOT REPRESENT OR WARRANT THAT THIS DOCUMENTATION IS FREE FROM ERRORS OR DEFECTS.
- c. IN NO EVENT SHALL BROTHER BE LIABLE FOR ANY DIRECT, INDIRECT, PUNITIVE, INCIDENTAL, SPECIAL, CONSEQUENTIAL DAMAGES OR ANY DAMAGES WHATSOEVER, ARISING OUT OF THE USE, INABILITY TO USE, OR THE RESULTS OF USE OF THE DOCUMENTATION OR ANY SOFTWARE PROGRAM OR APPLICATION YOU DEVELOPED IN ACCORDANCE WITH THE DOCUMENTATION.

[Contents]

| | |
|--|----|
| Control code list..... | 6 |
| Print area..... | 9 |
| Characters..... | 10 |
| Print position..... | 11 |
| Line feed amount..... | 12 |
| Document creation flow..... | 13 |
| Control command details..... | 15 |
| Character/style selection commands..... | 15 |
| ESC R Select international character set..... | 15 |
| ESC k Select font..... | 17 |
| ESC t Select character code table..... | 17 |
| Text printing commands..... | 18 |
| ESC 4 Apply italic style..... | 18 |
| ESC 5 Cancel italic style..... | 18 |
| ESC E Apply bold style..... | 18 |
| ESC F Cancel bold style..... | 19 |
| ESC G Apply double-strike printing..... | 19 |
| ESC H Cancel double-strike printing..... | 19 |
| ESC W Specify double-width characters..... | 20 |
| SI Specify compressed characters..... | 20 |
| ESC SI Specify compressed characters..... | 20 |
| DC2 Cancel compressed characters..... | 21 |
| ESC - Apply/cancel underlining..... | 21 |
| ESC ! Global formatting..... | 22 |
| ESC X Specify character size..... | 23 |
| ESC i f Apply/cancel a frame (global)..... | 23 |
| CAN Clear text..... | 23 |
| DEL Delete one character..... | 24 |
| ESC CR Not available..... | 24 |
| Line feed commands..... | 25 |
| ESC 0 Specify line feed of 1/8 inch..... | 25 |
| ESC 2 Specify line feed of 1/6 inch..... | 25 |
| ESC 3 Specify line feed of n/180 inch..... | 25 |
| ESC A Specify line feed of n/60 inch..... | 26 |
| Horizontal movement commands..... | 27 |

| | | |
|----------------------------------|---|----|
| CR | Carriage return..... | 27 |
| ESC \$ | Specify absolute horizontal position | 27 |
| ESC \ | Specify relative horizontal position | 28 |
| ESC a | Specify alignment | 28 |
| Vertical movement commands | | 29 |
| LF | Line feed | 29 |
| FF | Page feed | 29 |
| ESC J | Forward paper feed | 29 |
| Paper formatting..... | | 30 |
| ESC i l | Specify label length | 30 |
| ESC i m | Specify margin width | 30 |
| Printer control commands | | 31 |
| ESC @ | Initialize..... | 31 |
| Graphics commands | | 32 |
| ESC * | Select bit image..... | 32 |
| ESC K | 8-dot single-density bit image | 37 |
| ESC L | 8-dot double-density bit image | 38 |
| ESC Y | 8-dot double-speed double-density bit image | 39 |
| ESC Z | 8-dot quadruple-density bit image | 39 |
| Kanji commands..... | | 40 |
| FS Y | Specify kanji size..... | 40 |
| FS - | Apply kanji underlining..... | 40 |
| FS SI | Specify half-width characters..... | 41 |
| FS DC2 | Cancel half-width characters..... | 41 |
| FS k | Select font | 41 |
| Advanced commands..... | | 42 |
| ESC i B | Bar code | 42 |
| ESC i Q | 2D bar code (QR Code)..... | 46 |
| ESC i P | Specify QR Code version | 50 |
| ESC i V | 2D bar code (PDF417)..... | 51 |
| ESC i D | 2D bar code (DataMatrix) | 55 |
| ESC i M | 2D bar code (MaxiCode)..... | 58 |
| ESC i F | Print transferred data | 60 |
| ESC i a | Switch command mode | 64 |
| ESC i S | Request printer status | 65 |
| ESC i L | Apply/cancel rotated printing..... | 68 |
| ESC i C | Specify cut setting..... | 68 |

| | | |
|--|------------------------------|----|
| ESC i U B | Specify baud rate | 69 |
| ESC i U b | Specify bit length | 69 |
| ESC i U P | Specify parity setting | 70 |
| ESC i U C | Specify busy control | 70 |
| Character code | | 71 |
| Standard character code table for ESC/P codes | | 71 |
| Eastern European character code table (Windows 1250) | | 72 |
| Western European character code table (Windows 1252) | | 73 |
| BROTHER PT-9800PCN/9700PC ESC/P specifications | | 75 |

Control code list

Character/style selection

| | | |
|-------|-------|------------------------------------|
| ESC R | 1B 52 | Select international character set |
| ESC k | 1B 6B | Select font |
| ESC t | 1B 74 | Select character code table |

Text printing

| | | |
|---------|----------|---------------------------------|
| ESC 4 | 1B 34 | Apply italic style |
| ESC 5 | 1B 35 | Cancel italic style |
| ESC E | 1B 45 | Apply bold style |
| ESC F | 1B 46 | Cancel bold style |
| ESC G | 1B 47 | Apply double-strike printing |
| ESC H | 1B 48 | Cancel double-strike printing |
| ESC W | 1B 57 | Specify double-width characters |
| SI | 0F | Specify compressed characters |
| ESC SI | 1B 0F | Specify compressed characters |
| DC2 | 12 | Cancel compressed characters |
| ESC - | 1B 2D | Apply/cancel underlining |
| ESC ! | 1B 21 | Global formatting |
| ESC X | 1B 58 | Specify character size |
| ESC i f | 1B 69 66 | Apply/cancel a frame (global) |
| CAN | 18 | Clear text |
| DEL | 7F | Delete one character |
| ESC CR | 1B 0D | Not available |

Line feeds

| | | |
|-------|-------|--------------------------------|
| ESC 0 | 1B 30 | Specify line feed of 1/8 inch |
| ESC 2 | 1B 32 | Specify line feed of 1/6 inch |
| ESC 3 | 1B 33 | Specify minimum line feed |
| ESC A | 1B 41 | Specify line feed of n/60 inch |

Horizontal movement

| | | |
|--------|-------|--------------------------------------|
| CR | 0D | Carriage return |
| ESC \$ | 1B 24 | Specify absolute horizontal position |
| ESC \ | 1B 5C | Specify relative horizontal position |
| ESC a | 1B 61 | Specify alignment |

Vertical movement

| | | |
|-------|-------|--------------------|
| LF | 0A | Line feed |
| FF | 0C | Page feed |
| ESC J | 1B 4A | Forward paper feed |

Paper formatting

| | | |
|---------|----------|----------------------|
| ESC i l | 1B 69 6C | Specify label length |
| ESC i m | 1B 69 6D | Specify margin width |

Printer control

| | | |
|-------|-------|------------|
| ESC @ | 1B 40 | Initialize |
|-------|-------|------------|

Graphics commands

| | | |
|-------|-------|---|
| ESC * | 1B 2A | Select bit image |
| ESC K | 1B 4B | 8-dot single-density bit image |
| ESC L | 1B 4C | 8-dot double-density bit image |
| ESC Y | 1B 59 | 8-dot double-speed double-density bit image |
| ESC Z | 1B 5A | 8-dot quadruple-density bit image |

Kanji commands

| | | |
|--------|-------|-------------------------------|
| FS Y | 1C 59 | Specify kanji size |
| FS - | 1C 2D | Apply kanji underlining |
| FS SI | 1C 0F | Specify half-width characters |
| FS DC2 | 1C 12 | Cancel half-width characters |
| FS k | 1C 6B | Select font |

Advanced commands

| | | |
|-----------|-------------|-------------------------------|
| ESC i B | 1B 69 42 | Bar code |
| ESC i Q | 1B 69 51 | 2D bar code (QR Code) |
| ESC i P | 1B 69 50 | Specify QR Code version |
| ESC i V | 1B 69 56 | 2D bar code (PDF417) |
| ESC i D | 1B 69 44 | 2D bar code (DataMatrix) |
| ESC i M | 1B 69 4D | 2D bar code (MaxiCode) |
| ESC i F | 1B 69 46 | Print transferred data |
| ESC i a | 1B 69 61 | Switch command mode |
| ESC i S | 1B 69 53 | Request printer status |
| ESC i L | 1B 69 4C | Apply/cancel rotated printing |
| ESC i C | 1B 69 43 | Specify cut setting |
| ESC i U B | 1B 69 55 42 | Specify baud rate |
| ESC i U b | 1B 69 55 62 | Specify bit length |
| ESC i U P | 1B 69 55 50 | Specify parity setting |
| ESC i U C | 1B 69 55 43 | Specify busy control |

Print area

The print area for each tape width is listed below.

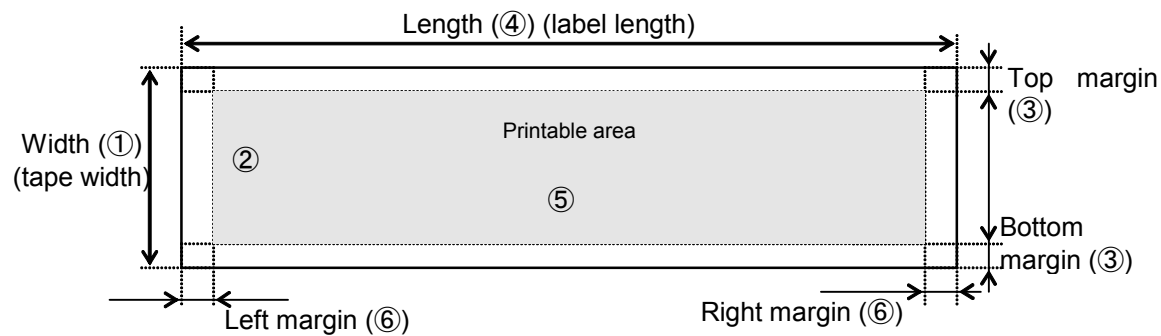

| Type | Width (mm) | Printable area (vertical) (mm/dots) | Top/bottom margins (mm) | Length (mm) | Printable area (horizontal) mm/dots | Left/right margins (mm) | Dot position ^{*1} | Max. no. of printed lines |
|------|------------|-------------------------------------|-------------------------|-------------|-------------------------------------|-------------------------|----------------------------|---------------------------|
| | ① | ② | ③ | ④ | ⑤ | ⑥ | | |
| 36 | 36 | 27.1/384 | 4.45 | / | / | / | 1 ~ 384 | 16 |
| 24 | 24 | 22.6/320 | 0.71 | / | / | / | 33 ~ 352 | 13 |
| 18 | 18 | 16.5/234 | 0.75 | / | / | / | 76 ~ 309 | 9 |
| 12 | 12 | 10.6/150 | 0.71 | / | / | / | 118 ~ 267 | 6 |
| 9 | 9 | 7.5/106 | 0.76 | / | / | / | 140 ~ 245 | 4 |
| 6 | 6 | 4.5/64 | 0.74 | / | / | / | 161 ~ 224 | 2 |
| 3.5 | 6 | 4.5/64 | 0.74 | / | / | / | 161 ~ 224 | 2 |

^{*1} The dot position for the lowest dot is specified as 1. (1 through 384)

- The maximum length (④) is 1 m, and the minimum left and right margins (⑥) are 1 mm.

Characters

<Overseas>

This system uses single-byte character codes and is installed with two bitmap fonts (Letter Gothic and Helsinki).

Each font has six sizes: 21 dots, 28 dots, 44 dots, 56 dots, 88 dots and 120 dots.

Character size

<Overseas>

Each font is available in full size, compressed (half width) and double width.

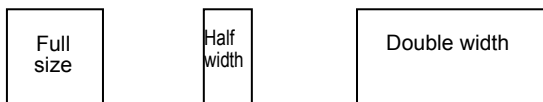

Line-drawing characters (┌ └ ┘ ┐ ┆ ┇ ┈ ┉) and shaded characters appear with the width of the Letter Gothic font, regardless of the specified font setting.

Print position

The print position is the standard position for printing characters, bitmaps and bar codes. With the print position, there is a horizontal print position, which is the reference point for vertical position movement.

Each character is arranged so that their top edge aligns with the print position. The baseline of each character is the bottom edge of the character, regardless of size, font, etc.

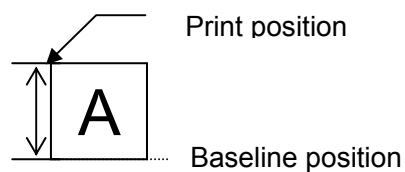

All characters on the same line are printed so that the baseline position is the same for each character.

If the text consists of characters with different heights, the characters are aligned on the baseline of the tallest character in the line of text.

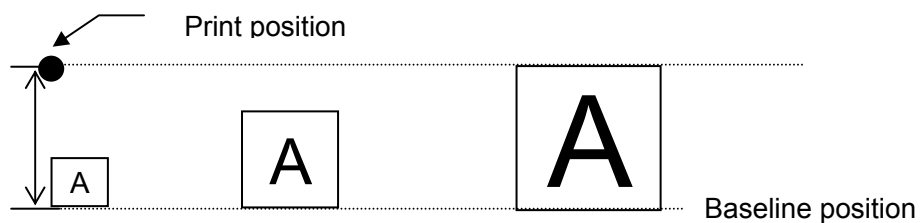

In addition, underlines are printed 4 dots below the baseline position.

Bitmaps, bar codes and transferred images

These types of image data are treated in the same way as characters and are printed so that the bottom edge of the image aligns with the baseline.

Same line

- Horizontal movement to the right between characters or images is regarded as being on the same line; however, movement to the left is regarded as being on different lines if text wrapping occurs.

Line feed amount

The line feed amount is the amount of vertical movement from the print position of one line to the print of the next line.

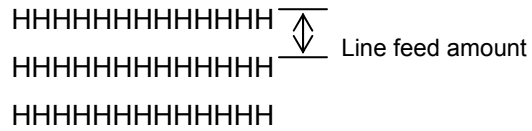

The line feed amount is specified using ESC 0, ESC 2, ESC A and ESC 3.

Document creation flow

The flow for creating documents is shown below.

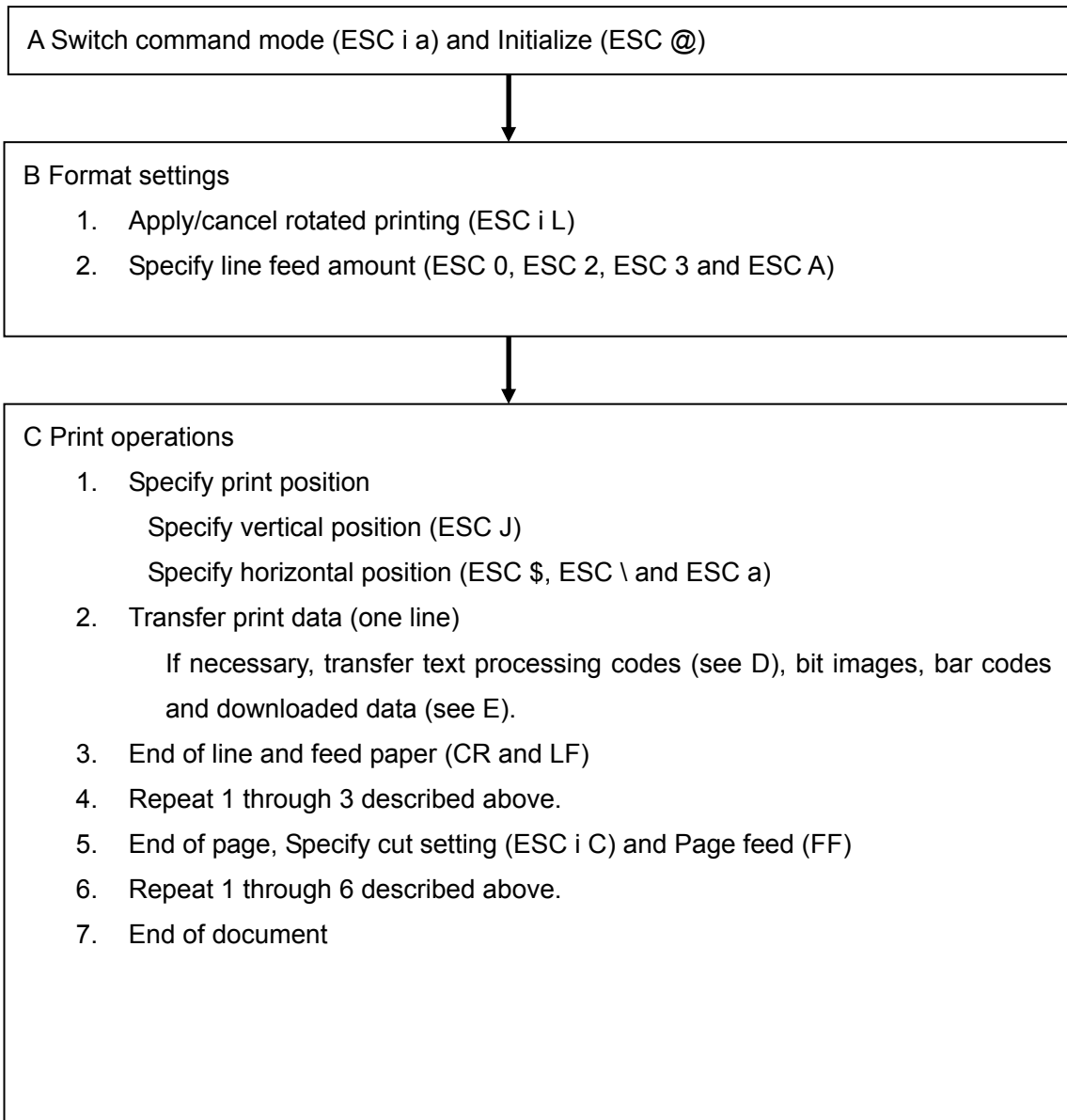

D Text operations

1. Select character set
 - Select font (ESC k)
 - Select character code (ESC t)
 - Select international character set (ESC R)
 - Specify character size (ESC X)
2. Character style (ESC 4, ESC 5, ESC E, ESC F, ESC G, ESC H, ESC W, SI, ESC SI, DC2, ESC – and ESC !)
3. Character code

*Repeat steps 1 through 3, as necessary.

E Bit image (ESC *, ESC K, ESC L, ESC Y and ESC Z)

Bar code (ESC i B)

2D bar code (ESC i Q, ESC i V and ESC i D)

Downloaded data (ESC i F)

With transferred data, the image data must first be transferred and saved on the main unit.

Control command details

Character/style selection commands

| |
|--|
| ESC R Select international character set |
|--|

[ASCII] ESC R n

[Decimal] 27 82 n

[Hexadecimal] 1B 52 n

[Parameters] $0 \leq n \leq 13, 64$

[Description]

- Selects the character set for the country, and switches some character codes in the code table according to the value of n.

n=0: USA

n=1: France

n=2: Germany

n=3: UK

n=4: Denmark

n=5: Sweden

n=6: Italy

n=7: Spain

n=8: Japan

n=9: Norway

n=10: Denmark II

n=11: Spain II

n=12: Latin America

n=13: South Korea

n=64: Legal

- The following 12 codes are changed.
23h, 24h, 40h, 5Bh, 5Ch, 5Dh,
5Eh, 60h, 7Bh, 7Ch, 7Dh, 7Eh
- The default setting is n=0 (USA) for overseas.
- When using the standard character code table, printing is performed according to the specified international character set.

[Example]

Code

5Ch ESC R 08h 5Ch FF

Print result

¥

| |
|----------------------|
| ESC k Select font |
|----------------------|

[ASCII] ESC k n

[Decimal] 27 107 n

[Hexadecimal] 1B 6B n

[Parameters] 0≤n≤1

[Description]

- Selects the font.

 Bitmap fonts

 n=0 Helsinki

 n=1 Letter Gothic

- The default value is n=0 (Helsinki).

| |
|--------------------------------------|
| ESC t Select character code table |
|--------------------------------------|

[ASCII] ESC t n

[Decimal] 27 116 n

[Hexadecimal] 1B 74 n

[Parameters] n=0, 1, 2

[Description]

- From the three built-in character code tables, select the character code table to be used.
- n=0: Standard character code table
- n=1: Eastern European character code table
- n=2: Western European character code table
- n=3: (Spare)
- The default setting is n=0.

Text printing commands

ESC 4 Apply italic style

[ASCII] ESC 4

[Decimal] 27 52

[Hexadecimal] 1B 34

[Parameters] None

[Description]

- Applies the italic style to the following text.

ESC 5 Cancel italic style

[ASCII] ESC 5

[Decimal] 27 53

[Hexadecimal] 1B 35

[Parameters] None

[Description]

- Cancels the italic style.

[Example]

Code

ABC ESC 4 DEF ESC 5 GHI FF

Print result

ABC*DEFGHI*

ESC E Apply bold style

[ASCII] ESC E

[Decimal] 27 69

[Hexadecimal] 1B 45

[Parameters] None

[Description]

- Prints the following text in bold.

ESC F Cancel bold style

[ASCII] ESC F

[Decimal] 27 70

[Hexadecimal] 1B 46

[Parameters] None

[Description]

- Cancels the bold style.

[Example]

Code

ABC ESC E DEF ESC F GHI FF

Print result

ABC**DE**FGHI

ESC G Apply double-strike printing

[ASCII] ESC G

[Decimal] 27 71

[Hexadecimal] 1B 47

[Parameters] None

[Description]

- Prints the following text in bold.

ESC H Cancel double-strike printing

[ASCII] ESC H

[Decimal] 27 72

[Hexadecimal] 1B 48

[Parameters] None

[Description]

- Cancels the bold style.

[Example]

Code

ABC ESC E DEF ESC F GHI FF

Print result

ABC**DE**FGHI

| |
|---------------------------------------|
| ESC W Specify double-width characters |
|---------------------------------------|

[ASCII] ESC W n

[Decimal] 27 87 n

[Hexadecimal] 1B 57 n

[Parameters] n=0 and 1 or 48 and 49

[Description]

- Specifies double-width characters.
- If n=1 or 49 (“1”), double-width characters are specified.
- If n=0 or 48 (“0”), double-width characters are cancelled.

[Example]

Code

ABC ESC W 1 ABC ESC W 0 ABC FF

Print result

ABC**ABC**ABC

| |
|----------------------------------|
| SI Specify compressed characters |
|----------------------------------|

[ASCII] SI

[Decimal] 15

[Hexadecimal] 0F

[Parameters] None

[Description]

- Prints the following text in half-width characters.

| |
|--------------------------------------|
| ESC SI Specify compressed characters |
|--------------------------------------|

[ASCII] ESC SI

[Decimal] 27 15

[Hexadecimal] 1B 0F

[Parameters] None

[Description]

- Same as SI

| | |
|-----|------------------------------|
| DC2 | Cancel compressed characters |
|-----|------------------------------|

[ASCII] DC2

[Decimal] 18

[Hexadecimal] 12

[Parameters] None

[Description]

- Cancels compressed characters specified with SI.

| | |
|-------|--------------------------|
| ESC - | Apply/cancel underlining |
|-------|--------------------------|

[ASCII] ESC - n

[Decimal] 27 45 n

[Hexadecimal] 1B 2D n

[Parameters] n=0 and 1 or 48 and 49

[Description]

Applies or cancels underlining.

- If n=1, underlining is applied.
- If n=0, underlining is cancelled.
- The underlining specified by this code is a continuous line.
- Spaces between characters and words are also underlined.

[Example]

Code

ABC ESC - 1 ABC ESC - 0 ABC FF

Print result

ABCABCABC

ESC ! Global formatting

[ASCII] ESC ! n

[Decimal] 27 33 n

[Hexadecimal] 1B 21 n

[Parameters] $0 \leq n \leq 255$

[Description]

- Specifies a combination of the various print modes.
- Specifies modes according to the bit value of n.
- A combination of multiple print modes can be specified at one time.

| Bit | 7 | 6 | 5 | 4 | 3 | 2 | 1 | 0 |
|-----|-----------|---------|----------|--------|--------|----------|----------|----------|
| 1 | Underline | Italics | Not used | Bold | Bold | Not used | Not used | Not used |
| 0 | Cancel | Cancel | Not used | Cancel | Cancel | Not used | Not used | Not used |

[Example] To apply underlining and the italic style at one time

Code

ABC ESC ! C0h ABC ESC ! 00h ABC FF

Print result

ABC*ABC*ABC

| |
|------------------------------|
| ESC X Specify character size |
|------------------------------|

[ASCII] ESC X n

[Decimal] 27 88 n

[Hexadecimal] 1B 58 n

[Parameters] $0 \leq n \leq 6$ or $30h \leq n \leq 36h$

[Description]

- Specifies the character size.
- The character size can be set to AUTO or a fixed size (six sizes).
 - If n=0 (or 30h), the AUTO size is applied.
 - If n=1 (or 31h), the 4-point size is applied. (21 dots)
 - If n=2 (or 32h), the 6-point size is applied. (28 dots)
 - If n=3 (or 33h), the 9-point size is applied. (44 dots)
 - If n=4 (or 34h), the 12-point size is applied. (56 dots)
 - If n=5 (or 35h), the 18-point size is applied. (88 dots)
 - If n=6 (or 36h), the 24-point size is applied. (120 dots)
- Same as FS Y

| |
|---------------------------------------|
| ESC i f Apply/cancel a frame (global) |
|---------------------------------------|

[ASCII] ESC i f

[Decimal] 27 105 102

[Hexadecimal] 1B 69 66

[Parameters] $0 \leq n \leq 1$ or $30h \leq n \leq 31h$

[Description]

- Applies a frame around the entire text.
 - If n=0 (or 30h), the frame is cancelled.
 - If n=1 (or 31h), a frame is applied.

| |
|----------------|
| CAN Clear text |
|----------------|

[ASCII] CAN

[Decimal] 24

[Hexadecimal] 18

[Parameters] None

[Description]

- Clears all text, image data and bar codes that were received.

| | |
|-----|----------------------|
| DEL | Delete one character |
|-----|----------------------|

[ASCII] DEL

[Decimal] 127

[Hexadecimal] 7F

[Parameters] None

[Description]

- The immediately preceding character within the same line is deleted.
- If the immediately preceding data is a bar code, the bar code is deleted.
- Image data is not deleted.

| | |
|--------|---------------|
| ESC CR | Not available |
|--------|---------------|

[ASCII] ESC CR n

[Decimal] 27 13 n

[Hexadecimal] 1B 0D n

[Parameters] $0 \leq n \leq 255$

[Description]

- Does nothing.

Line feed commands

ESC 0 Specify line feed of 1/8 inch

[ASCII] ESC 0

[Decimal] 27 48

[Hexadecimal] 1B 30

[Parameters] None

[Description]

- Specifies a line feed of 1/8 inch (approximately 0.32 cm).

ESC 2 Specify line feed of 1/6 inch

[ASCII] ESC 2

[Decimal] 27 50

[Hexadecimal] 1B 32

[Parameters] None

[Description]

- Specifies a line feed of 1/6 inch (approximately 0.42 cm).

ESC 3 Specify line feed of n/180 inch

[ASCII] ESC 3 n

[Decimal] 27 51 n

[Hexadecimal] 1B 33 n

[Parameters] $0 \leq n \leq 255$

[Description]

- Specifies a line feed of n/180 inch per text line.
- If n is less than 24, the line feed amount is set to 24/180 inch (approximately 0.34 cm).

| |
|--------------------------------------|
| ESC A Specify line feed of n/60 inch |
|--------------------------------------|

[ASCII] ESC A n

[Decimal] 27 65 n

[Hexadecimal] 1B 41 n

[Parameters] $0 \leq n \leq 255$

[Description]

- Specifies a line feed of n/60 inch per text line.
- If n is less than 8, the line feed amount is set to 8/60 inch (approximately 0.34 cm).

Horizontal movement commands

| | |
|----|-----------------|
| CR | Carriage return |
|----|-----------------|

[ASCII] CR

[Decimal] 13

[Hexadecimal] 0D

[Parameters] None

[Description]

- Performs a line feed of the amount specified by a line feed command (ESC 0, ESC 2, ESC 3 and ESC A).
- If no line feed amount has been specified, it is automatically specified depending on the width of the tape.
- The next print position is the beginning of the next line.
- A line feed command immediately after a carriage return is ignored.

| | |
|--------|--------------------------------------|
| ESC \$ | Specify absolute horizontal position |
|--------|--------------------------------------|

[ASCII] ESC \$ n1 n2

[Decimal] 27 36 n1 n2

[Hexadecimal] 1B 24 n1 n2

[Parameters] $0 \leq n1 \leq 255$, $0 \leq n2 \leq 255$

[Description]

- Specifies an absolute print position (in units of 1/60 inch) for the next data.
- An absolute print position specifies the horizontal print position from the left margin.
- The next character is printed at a position $(n1 + 256 * n2) / 60$ inch from the left margin.
 - * However, since the printable length is 1 meter, an actual value greater than $2362/60$ inches will result in an error during printing

| |
|--|
| ESC \ Specify relative horizontal position |
|--|

[ASCII] ESC \ n1 n2

[Decimal] 27 92 n1 n2

[Hexadecimal] 1B 5C n1 n2

[Parameters] $0 \leq n1 \leq 255, 0 \leq n2 \leq 255$

[Description]

- Specifies a relative print position (in units of 1/180 inch) for the next data.
- A relative print position specifies the horizontal print position based on the current position.
- The next character is printed at a position $(n1 + 256 * n2) / 180$ inch from the current position.
- A relative position cannot be specified to the left (in the negative direction).
 - ※ However, since the printable length is 1 meter, an actual value greater than 7086/180 inches will result in an error during printing
- This command is available only with left alignment.

| |
|-------------------------|
| ESC a Specify alignment |
|-------------------------|

[ASCII] ESC a n

[Decimal] 27 97 n

[Hexadecimal] 1B 61 n

[Parameters] $0 \leq n \leq 3$ or "0" $\leq n \leq$ "3"

[Description]

- The following data is printed with the alignment described below, depending on the value of n.
 - n=0 specifies left alignment.
 - n=1 specifies center alignment.
 - n=2 specifies right alignment.
 - n=3 specifies justified alignment.
- The default setting is n=0.
- The last alignment setting received is applied to all of the print data.
- If an absolute horizontal position or a relative horizontal position is specified, the text must be aligned on the left when it is printed.

Vertical movement commands

| | |
|----|-----------|
| LF | Line feed |
|----|-----------|

[ASCII] LF

[Decimal] 10

[Hexadecimal] 0A

[Parameters] None

[Description]

- Performs the same line feed operation as CR.
- A carriage return command immediately after a line feed is ignored.

| | |
|----|-----------|
| FF | Page feed |
|----|-----------|

[ASCII] FF

[Decimal] 12

[Hexadecimal] 0C

[Parameters] None

[Description]

- Starts printing.
- Clears the text, image data and bar codes after printing.
- If the data does not fit within the printable height of the tape, the data is divided and printed onto multiple pages.
- If the length of the print data exceeds 1 meter, the LED lights up to indicate that an error has occurred.

| | |
|-------|--------------------|
| ESC J | Forward paper feed |
|-------|--------------------|

[ASCII] ESC J n

[Decimal] 27 74 n

[Hexadecimal] 1B 4A n

[Parameters] $0 \leq n \leq 255$

[Description]

- Finishes input of the current line, then moves the vertical print position forward by $n/180$ inch.
- If n is less than 24, the feed amount is $24/180$ inch (approximately 0.34 cm).

Paper formatting

ESC i l Specify label length

[ASCII] ESC i l n1 n2

[Decimal] 27 105 108 n1 n2

[Hexadecimal] 1B 69 6C n1 n2

[Parameters] len=n1+n2×256

(len=0 or 36≤len≤7200)

[Description]

- Specifies the label length (len) in units of 1/180 inch.
- The range in which the label length can be set is 0.2 to 40 inches.
- len=0 specifies the AUTO setting.

ESC i m Specify margin width

[ASCII] ESC i m n1 n2

[Decimal] 27 105 109 n1 n2

[Hexadecimal] 1B 69 6D n1 n2

[Parameters] mgn=n1+n2×256

(7≤mgn≤720)

[Description]

- Specifies the margin width (mgn) in units of 1/180 inch.
- The range in which the margin width can be set is 0.04 to 4 inches.

Printer control commands

ESC @ Initialize

[ASCII] ESC @

[Decimal] 27 64

[Hexadecimal] 1B 40

[Parameters] None

[Description]

- Resets all parameters to their default settings. (See below.)

| Item | After Initialization |
|--|--|
| Command mode (ESC/P, Raster or P-touch Template) | No change |
| Communication settings (Baud rate, Parity, Bit length and Busy control) | No change |
| Received text and bar codes | Cleared |
| Received image data | Cleared |
| Line feed amount | AUTO |
| Relative position setting | Cleared |
| Absolute position setting | Cleared |
| Font | Helsinki |
| Character size | AUTO |
| Italics | OFF |
| Bold/double-strike printing | OFF |
| Underline | OFF |
| Character width | Normal (Half-width and double-width characters are cancelled.) |
| Character code table | Standard character code table |
| International character set | USA |
| Frame | None |
| Rotate | OFF |
| Text alignment | Left |
| Margins | 2 mm |
| Label length setting | AUTO |
| Bar code protocol | CODE39 |
| Bar code width | Small |
| Bar code ratio | 3:1 |
| Bar code check digit | OFF |
| Characters below bar codes | ON |
| Full cut | ON |
| Half cut | ON |
| Chain printing | OFF |

Graphics commands

| | |
|-------|------------------|
| ESC * | Select bit image |
|-------|------------------|

[ASCII] ESC * m n1 n2 data

[Decimal] 27 42 m n1 n2 data

[Hexadecimal] 1B 2A m n1 n2 data

[Parameters] m=0, 1, 2, 3, 4, 6, 32, 33, 38, 39, 40, 71, 72 or 73

$0 \leq n1 \leq 255, 0 \leq n2 \leq 255$

The data contains image data that is $n1 + n2 * 256$ bytes when $m=0, 1, 2, 3, 4$ or 6 ,

$(n1 + n2 * 256) * 3$ bytes when $m=32, 33, 38, 39$ or 40 ,

or $(n1 + n2 * 256) * 6$ bytes when $m=71, 72$ or 73 .

[Description]

- Selects and outputs a bit image according to the value of m.
- n1 and n2 indicate the number of dot positions.

n1: The remainder from dividing the number of dot positions by 256

n2: The quotient from dividing the number of dot positions by 256

| m | Horizontal dot density | Vertical dot density | Horizontal dot resolution | Vertical dot resolution |
|----|------------------------|----------------------|---------------------------|-------------------------|
| 0 | 60 DPI | 60 DPI | 6/360 inch | 6/360 inch |
| 1 | 120 DPI | 60 DPI | 3/360 inch | 6/360 inch |
| 2 | 120 DPI | 60 DPI | 3/360 inch | 6/360 inch |
| 3 | 240 DPI | 60 DPI | 2/360 inch | 6/360 inch |
| 4 | 80 DPI | 60 DPI | 4/360 inch | 6/360 inch |
| 6 | 90 DPI | 60 DPI | 4/360 inch | 6/360 inch |
| 32 | 60 DPI | 180 DPI | 6/360 inch | 2/360 inch |
| 33 | 120 DPI | 180 DPI | 3/360 inch | 2/360 inch |
| 38 | 90 DPI | 180 DPI | 4/360 inch | 2/360 inch |
| 39 | 180 DPI | 180 DPI | 2/360 inch | 2/360 inch |
| 40 | 360 DPI | 180 DPI | 1/360 inch | 2/360 inch |
| 71 | 180 DPI | 360 DPI | 2/360 inch | 1/360 inch |
| 72 | 360 DPI | 360 DPI | 1/360 inch | 1/360 inch |
| 73 | 360 DPI | 360 DPI | 1/360 inch | 1/360 inch |

When m=0, 1, 2, 3, 4 or 6

- n1 and n2 indicate the number of dot positions.

n1: The remainder from dividing the number of dot positions by 256

n2: The quotient from dividing the number of dot positions by 256

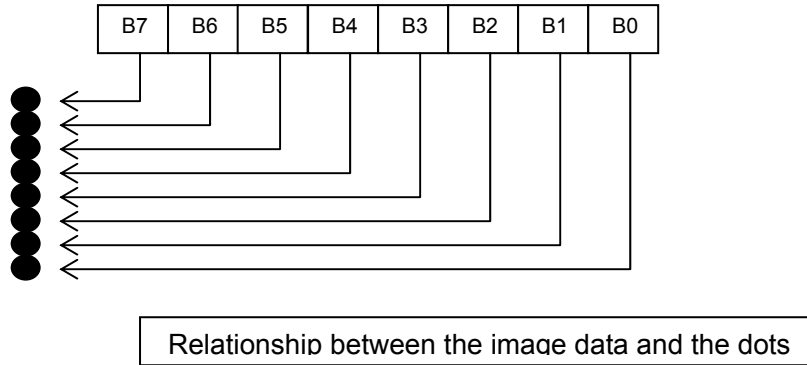

- First, the data is lined up in one row as shown below.

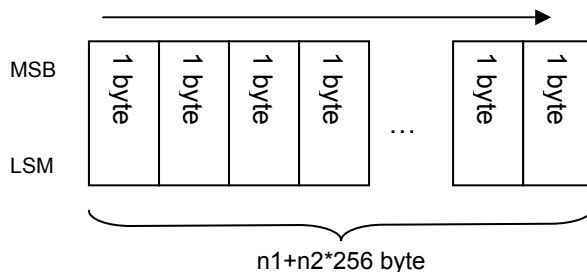

- One dot of the image data is enlarged according to the value of m, as shown below.

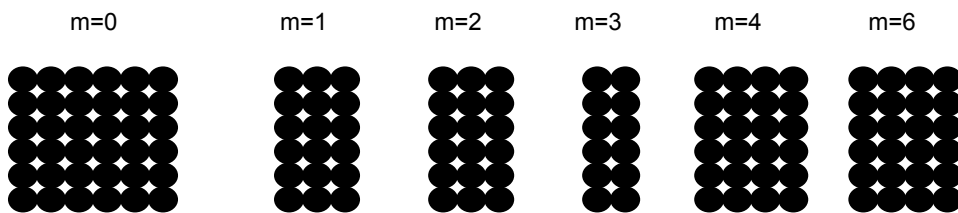

- As a result, the image is sized depending on the value of m, as shown below.

| | |
|-----|--|
| m=0 | 48 dots vertically × (n1 + n2 * 256) * 6 dots horizontally |
| m=1 | 48 dots vertically × (n1 + n2 * 256) * 3 dots horizontally |
| m=2 | 48 dots vertically × (n1 + n2 * 256) * 3 dots horizontally |
| m=3 | 48 dots vertically × (n1 + n2 * 256) * 2 dots horizontally |
| m=4 | 48 dots vertically × (n1 + n2 * 256) * 4 dots horizontally |
| m=6 | 48 dots vertically × (n1 + n2 * 256) * 4 dots horizontally |

When $m=32, 33, 38, 39$ or 40

- n_1 and n_2 indicate the number of dot positions.

n_1 : The remainder from dividing the number of dot positions by 256

n_2 : The quotient from dividing the number of dot positions by 256

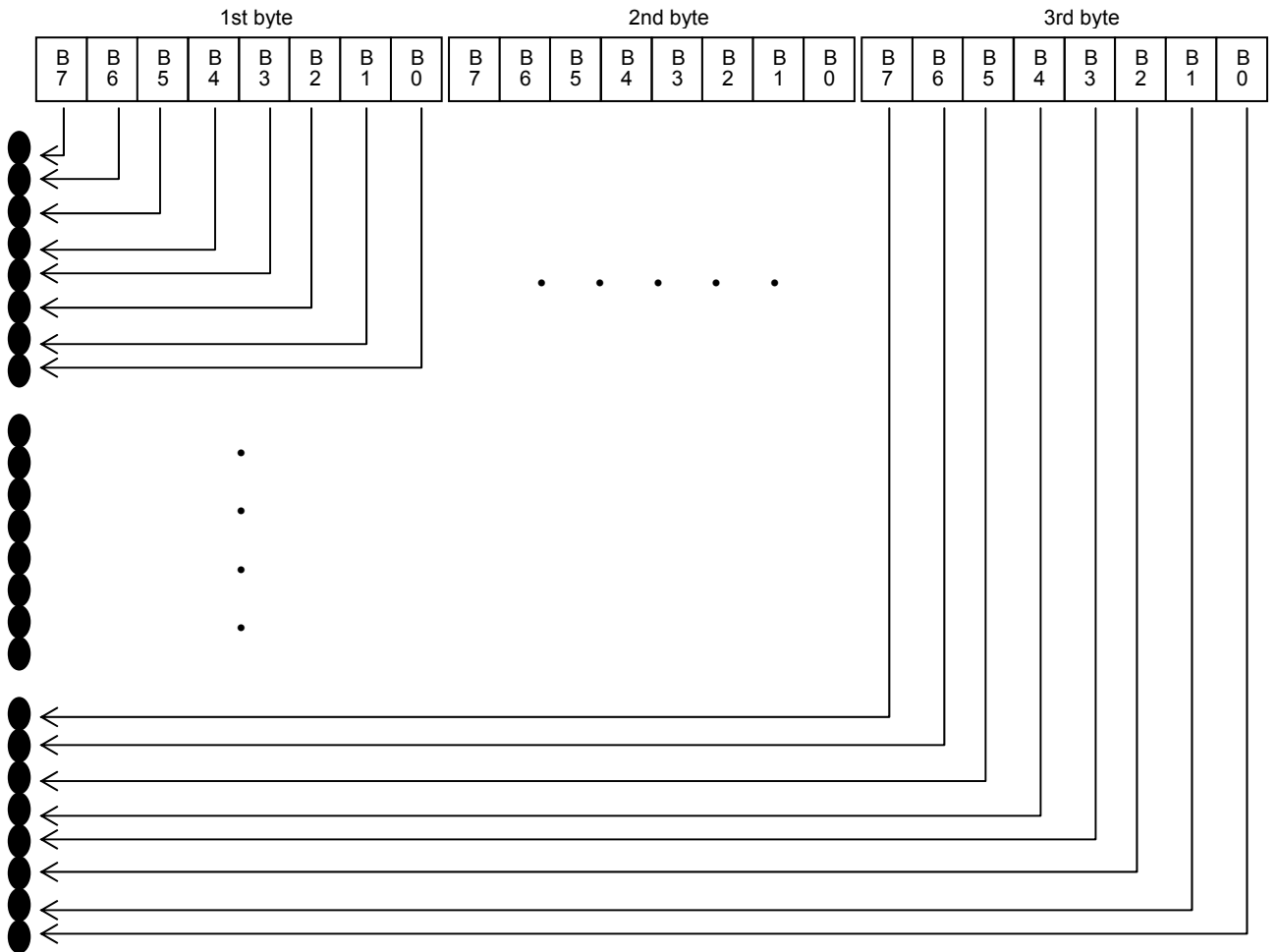

Relationship between the image data and the dots

- First, the data is lined up in three rows as shown below.

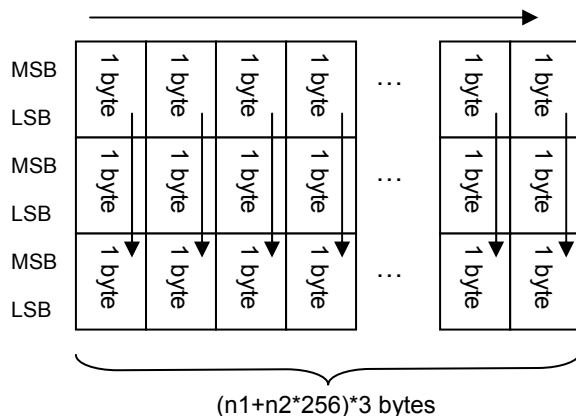

- One dot of the image data is enlarged according to the value of m, as shown below.

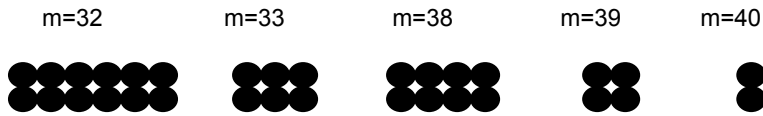

- As a result, the image is sized depending on the value of m, as shown below.

| | |
|------|--|
| m=32 | 48 dots vertically × (n1 + n2 * 256) * 6 dots horizontally |
| m=33 | 48 dots vertically × (n1 + n2 * 256) * 3 dots horizontally |
| m=38 | 48 dots vertically × (n1 + n2 * 256) * 4 dots horizontally |
| m=39 | 48 dots vertically × (n1 + n2 * 256) * 2 dots horizontally |
| m=40 | 48 dots vertically × (n1 + n2 * 256) * 4 dots horizontally |

When m=71, 72 or 73

- n1 and n2 indicate the number of dot positions. Specify their values as shown below.

n1: The remainder from dividing the number of dot positions by 256

n2: The quotient from dividing the number of dot positions by 256

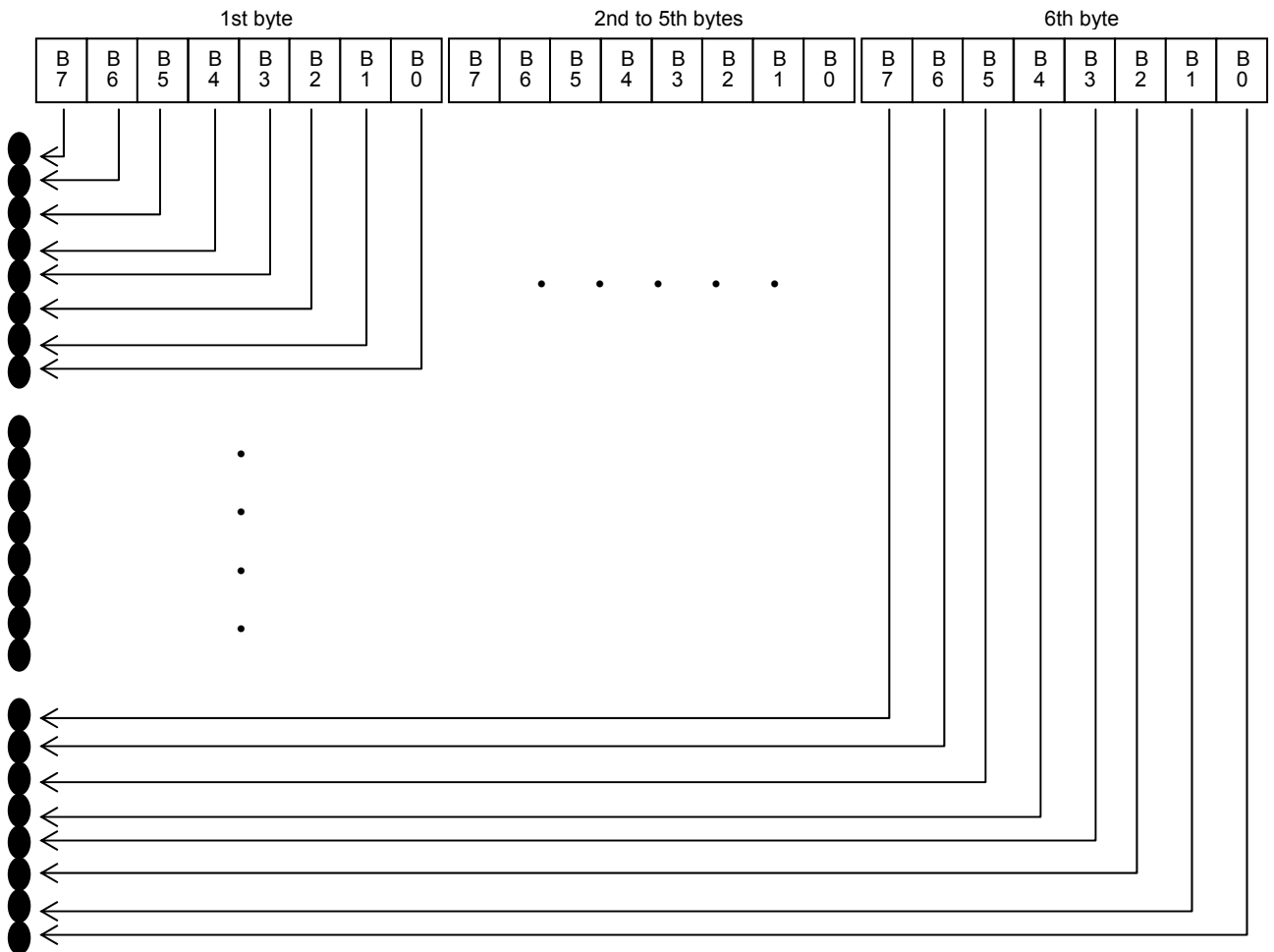

Relationship between the image data and the dots

- First, the data is lined up in six rows as shown below.

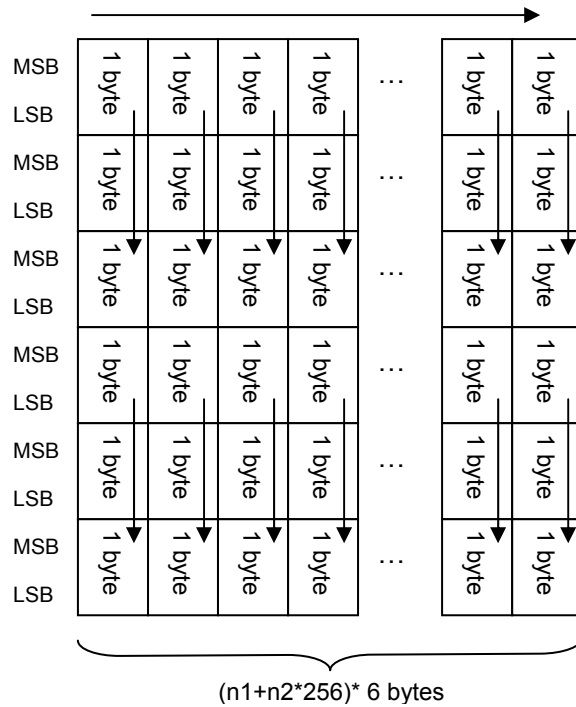

- One dot of the image data is enlarged according to the value of m , as shown below.

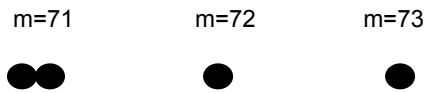

- As a result, the image is sized depending on the value of m , as shown below.

$m=71$ 48 dots vertically \times $(n_1 + n_2 * 256) * 2$ dots horizontally
 $m=72$ 48 dots vertically \times $(n_1 + n_2 * 256) * 1$ dot horizontally
 $m=73$ 48 dots vertically \times $(n_1 + n_2 * 256) * 1$ dot horizontally

ESC K 8-dot single-density bit image

[ASCII] ESC K n1 n2 data
 [Decimal] 27 75 n1 n2 data
 [Hexadecimal] 1B 4B n1 n2 data
 [Parameters] $0 \leq n1 \leq 255, 0 \leq n2 \leq 255$

The data contains image data that is $n1 + n2 * 256$ bytes.

[Description]

Specifies that an 8-dot standard-density bit image will be printed with the number of dot positions defined by n1 and n2.

- n1 and n2 indicate the number of dot positions.

n1: The remainder from dividing the number of dot positions by 256

n2: The quotient from dividing the number of dot positions by 256

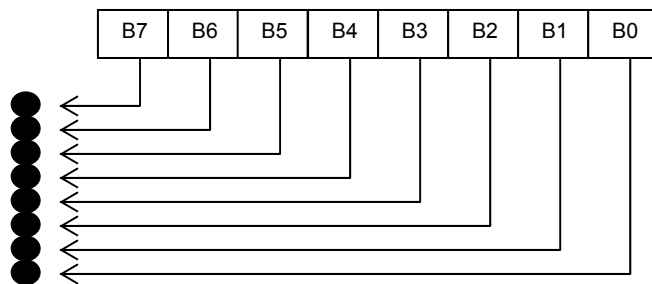

Relationship between the image data and the dots

- First, the data is lined up in one row as shown below.

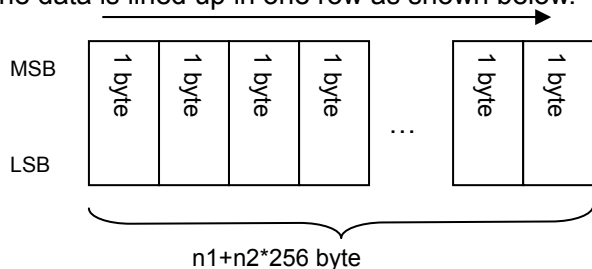

- One dot of the image data is enlarged to 6 dots vertically by 6 dots horizontally.

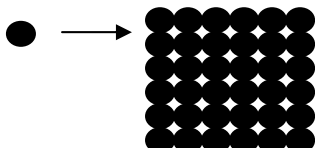

- As a result, the image becomes 48 dots vertically $\times (n1 + n2 * 256) * 6$ dots horizontally.

ESC L 8-dot double-density bit image

[ASCII] ESC L n1 n2 data
 [Decimal] 27 76 n1 n2 data
 [Hexadecimal] 1B 4C n1 n2 data
 [Parameters] $0 \leq n1 \leq 255, 0 \leq n2 \leq 255$

The data contains image data that is $n1 + n2 * 256$ bytes.

[Description]

Specifies that an 8-dot double-density bit image will be printed with the number of dot positions defined by n1 and n2.

- Specify n1 and n2 in the same way as with ESC K.
- First, the data is lined up in one row as shown below.

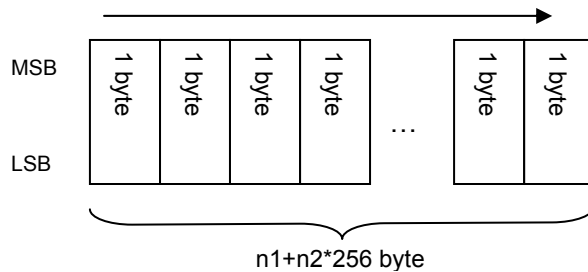

- One dot of the image data is enlarged to 6 dots vertically by 3 dots horizontally.

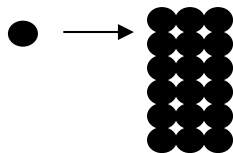

- As a result, the image becomes 48 dots vertically $\times (n1 + n2 * 256) * 3$ dots horizontally.

ESC Y 8-dot double-speed double-density bit image

[ASCII] ESC Y n1 n2 data
[Decimal] 27 89 n1 n2 data
[Hexadecimal] 1B 59 n1 n2 data
[Parameters] $0 \leq n1 \leq 255, 0 \leq n2 \leq 255$

The data contains image data that is $n1 + n2 * 256$ bytes.

[Description]

- Specifies that an 8-dot double-speed double-density bit image will be printed with the number of dot positions defined by n1 and n2.
- Specify n1 and n2 in the same way as with ESC K.

ESC Z 8-dot quadruple-density bit image

[ASCII] ESC Z n1 n2 data
[Decimal] 27 90 n1 n2 data
[Hexadecimal] 1B 5A n1 n2 data
[Parameters] $0 \leq n1 \leq 255, 0 \leq n2 \leq 255$

The data contains image data that is $n1 + n2 * 256$ bytes.

[Description]

Specifies that an 8-dot double-density bit image will be printed with the number of dot positions defined by n1 and n2.

- Specify n1 and n2 in the same way as with ESC K.
- First, the data is lined up in one row as shown below.

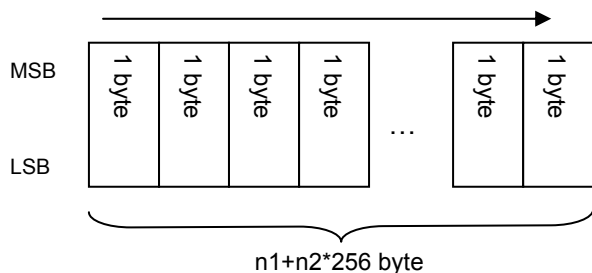

- One dot of the image data is enlarged to 6 dots vertically by 2 dots horizontally.

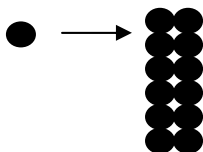

- As a result, the image becomes 48 dots vertically $\times (n1 + n2 * 256) * 2$ dots horizontally.

Kanji commands

| | |
|------|--------------------|
| FS Y | Specify kanji size |
|------|--------------------|

[ASCII] FS Y n

[Decimal] 28 89 n

[Hexadecimal] 1C 59 n

[Parameters] $0 \leq n \leq 6$ or $30h \leq n \leq 36h$

[Description]

- Specifies the character size.
- The character size can be set to AUTO or a fixed size (six sizes).
 - If $n=0$ (or $30h$), the AUTO size is applied.
 - If $n=1$ (or $31h$), the 4-point size is applied. (21 dots)
 - If $n=2$ (or $32h$), the 6-point size is applied. (28 dots)
 - If $n=3$ (or $33h$), the 9-point size is applied. (44 dots)
 - If $n=4$ (or $34h$), the 12-point size is applied. (56 dots)
 - If $n=5$ (or $35h$), the 18-point size is applied. (88 dots)
 - If $n=6$ (or $36h$), the 24-point size is applied. (120 dots)

| | |
|------|-------------------------|
| FS - | Apply kanji underlining |
|------|-------------------------|

[ASCII] FS - n

[Decimal] 28 45 n

[Hexadecimal] 1C 2D n

[Parameters] $n=0$ and 1 or 48 and 49

[Description]

- Applies or cancels underlining.
- If $n=1$, underlining is applied.
- If $n=0$, underlining is cancelled.
- The underlining specified by this code is a continuous line.
- Spaces between characters and words are also underlined.

FS SI Specify half-width characters

[ASCII] FS SI

[Decimal] 28 15

[Hexadecimal] 1C 0F

[Parameters] None

[Description]

- Same as SI

FS DC2 Cancel half-width characters

[ASCII] FS DC2

[Decimal] 28 18

[Hexadecimal] 1C 12

[Parameters] None

[Description]

- Same as DC2

FS k Select font

[ASCII] FS k n

[Decimal] 28 107 n

[Hexadecimal] 1C 6B n

[Parameters] $0 \leq n \leq 1$ or $30h \leq n \leq 31h$

[Description]

- Selects the font.

Bitmap fonts

n=0 (or 30h) Helsinki

n=1 (or 31h) Letter Gothic

- The default value is n=0 (Helsinki).

Advanced commands

| |
|------------------|
| ESC i B Bar code |
|------------------|

[ASCII] ESC i [parameters] B or b [bar code data] backslash
[Decimal] 27 105 [parameters] 66 or 98 [bar code data] 92
[Hexadecimal] 1B 69 [parameters] 42 or 62 [bar code data] 5C
[Parameters]

① [Parameters]: Bar code parameters

T or t (type)

t0: CODE39
t1: ITF (I-2/5)
t2: EAN-13
t3: EAN-8
t4: UPC-A
t5: EAN-8 (when the bar code data contains 7 characters)
UPC-A (when the bar code data contains 11 characters)
EAN-13 (when the bar code data contains 12 characters)
* The check digit mark “?” is not included in the number of characters.
t6: UPC-E
t9: CODABAR
ta: CODE128
tb: GS1-128 (UCC/EAN-128)
tc: RSS symbols

s (style) Ignored

p (number of passes) Ignored

R or r (characters below bar code)

r0: OFF

r1: ON

u (units of measurement) Ignored

x (horizontal position) Ignored

y (vertical offset) Ignored

h (height)

h n1 n2

Height = n1 + n2 * 256 (dots)

$48 \leq \text{height} \leq 384$

If height < 48, height = 48.

If height > 384, height = 384.

However, with tc, the height is as described below.

$141 \leq \text{height} \leq 384$ (RSS-14 Standard)

$81 \leq \text{height} \leq 384$ (RSS-14 Truncated)

$81 \leq \text{height} \leq 384$ (RSS-14 Stacked)

$249 \leq \text{height} \leq 384$ (RSS-14 Stacked Omni)

$72 \leq \text{height} \leq 384$ (RSS Limited)

$144 \leq \text{height} \leq 384$ (RSS Expanded)

If height < min., height = min.

If height > max., height = max.

(A bar code with a large number of stacked rows may be considered out of specifications and unreadable by the reader.)

w (width)

w0: small

w1: medium

w2: large

E or e (parentheses removed)

e0: ON

e1: OFF

o (RSS symbols model)

o0: RSS-14 Standard

o1: RSS-14 Truncated

o2: RSS-14 Stacked

o3: RSS-14 Stacked Omnidirectional

o4: RSS Limited

o5: RSS Expanded Standard

o6: RSS Expanded Stacked

c (number of horizontal characters for RSS Expanded Stacked)

c No. of horizontal characters

This must be an even value where $2 \leq \text{no. of horizontal characters} \leq 20$.

z (ratio between thick and thin bars)

z0: (3:1)

z1: (2.5:1)

z2: (2:1)

* Note:

- Both 00H through 09H and 30H through 39H are recognized as the parameter numbers 0 through 9.
- Parameter types a and b are recognized, even if they are uppercase letters.
- The parameter "parentheses removed" is available only when GS1-128 (UCC/EAN-128) is selected.
- The parameter "ratio between thick and thin bars" is available only when t0, t1 or t9 is selected.
- If there is no type command or if an invalid type command has been specified, Code 39 is specified.
- The number of characters that can be entered for each bar code protocol is listed below.

t0: 1 to 50 characters (not including "*" on both sides)

t1: 1 to 64 characters

t5: 7 characters (EAN-8), 12 characters (EAN-13), 11 characters (UPC-A)

t6: 6 characters

t9: 3 to 64 characters (with "A", "B", "C" or "D" at the beginning and end)

ta: 1 to 64 characters

tb: 1 to 64 characters

tc: 3 to 15 characters (begins with "01") (except with RSS Expanded)

1 to 64 numbers or 1 to 40 letters* (for RSS Expanded)

* ISO646 characters can be printed.

(numbers, letters, spaces, !, ", %, &, ', (,), *, +, ,, -, ., /, :, ;, <, =, >, ? and _)

② B or b: Beginning of bar code data

③ [Bar code data]: Data for the bar code

? (generate check digit)

Generates a check digit when "?" is in the bar code data

The position of "?" is irrelevant as long as it is within the bar code data.

With CODE128 and GS1-128 (UCC/EAN-128), no check digit is generated.

If "?" is entered, "?" is treated as bar code data.

④ Backslash: End of bar code data

[With protocols CODE39, ITF (I-2/5), EAN-8, EAN-13, UPC-A, UPC-E, CODABAR and RSS symbols]

ESC i [parameters] B or b [bar code data] \

[With protocols CODE128 and GS1-128 (UCC/EAN-128)]

ESC i [parameters] B or b [bar code data] \\

[Description]

- Specifies a bar code image.
- Since the check digit is automatically generated from the bar code data, the check digit is not sent as bar code data.

Since the length of the bar code data is also checked, the data would not be correctly recognized if check digit data is present.

- With protocols CODE39, ITF (I-2/5), CODABAR, CODE128, GS1-128 (UCC/EAN-128) or RSS Expanded, the buffer length for the bar code image is about 22 cm. A bar code longer than 22 cm will not be printed.
- The characters that can be entered with CODE128 and GS1-128 (UCC/EAN-128) are the full 128 ASCII characters and the special codes FNC1, FNC2, FNC3 and FNC4.

Codes assigned to the special codes

FNC1: 86H

FNC2: 81H

FNC3: 80H

FNC4: 84H

- The control codes and special codes appear as spaces when characters are printed below CODE128 and GS1-128 (UCC/EAN-128) bar codes.
- Special code FNC1 can also be printed with RSS Expanded. This special code also appears as a space when characters are printed below the bar code.

Code assigned to the special code

FNC1: 86H

ESC i Q 2D bar code (QR Code)

[ASCII] ESC i Q data

[Decimal] 27 105 81 data

[Hexadecimal] 1B 69 51 data

• Format

ESC i Q [parameters] [bar code data] \\\

①

②

③

① Parameters

Unlike with 1D bar codes, all parameters must be specified in order, starting from the top.

If a value other than those listed is entered for a parameter, that parameter is set to its default value.

| | | |
|--|--|--|
| 1. Cell size [1-byte decimal] 4 [1-byte decimal] 6 [1-byte decimal] 8 [1-byte decimal] 10 [1-byte decimal] 12 | Specifies the dot size per cell side. Prints 4 dots per cell side. (default value) Prints 6 dots per cell side. Prints 8 dots per cell side. Prints 10 dots per cell side. Prints 12 dots per cell side. | |
| 2. Symbol type [1-byte decimal] 1 [1-byte decimal] 2 [1-byte decimal] 3 | MODEL1 MODEL2 (default value) Micro QR | |
| 3. Linkage setting [1-byte decimal] 0 [1-byte decimal] 1 | Not linked Linked (*1) | |
| 4. Code number [1-byte decimal] 1 to 16 | Indicates the number of the QR Code that is linked | |
| 5. Number of partitions [1-byte decimal] 2 to 16 | Indicates the total number of the QR Code that are linked | |
| 6. Parity data [1-byte hexadecimal] 00 to FF | Value (in bytes) of exclusively OR'ing all print data (print data before partition) | |
| 7. Error correction level [1-byte decimal] 1 [1-byte decimal] 2 [1-byte decimal] 3 [1-byte decimal] 4 | High-density level L 7% Standard level M 15% (default value) High-reliability level Q 25% Ultra-high-reliability level H 30% (*2) | |
| 8. Data input method [1-byte decimal] 0 [1-byte decimal] 1 | Auto input (default value) Manual input Selects whether numerals, alphanumeric characters, kanji characters or binary characters are entered. | |

(*1) With Micro QR, the linkage setting is invalid, and the default setting is used.

(*2) With Micro QR, error correction level 4 is invalid, and the default setting is used.

◆ Supplement: About QR Code linkage setting

QR Codes have a linkage setting.

A long character string can be divided into 2 to 16 partitions and printed.

With ESC/P commands, it is necessary to enter only the number of partitions.

For example, enter the bar code data as shown below when the print data is separated into three partitions.

ESC i Q or q [parameters for 1st set] [1st set of bar code data] \\\

ESC i Q or q [parameters for 2nd set] [2nd set of bar code data] \\\

ESC i Q or q [parameters for 3rd set] [3rd set of bar code data] \\\

3. Linkage setting: This determines whether or not the bar code data is partitioned. If the data is not partitioned, enter "0".

If the data is not partitioned, the values for 4. Code number, 5. Number of partitions, and 6. Parity data are ignored, therefore, enter "0" as a dummy for these parameters.

4. Code number: This indicates which number the ESC/P command for that QR Code is for.

For example, if it is the second of four partitions, this value is "2". If it is the fourth, this value is "4".

5. Number of partitions: For this, enter the number of partitions.

6. Parity data: This is the value (**in bytes**) of **exclusively OR'ing** all print data (print data before partitioning). Entering the same value as for the partitioned QR Code ESC/P command indicates that the codes are linked.

About exclusive OR'ing in bytes

Data is exclusively OR'ed (XOR'ed) in bytes and in order.

For example, the hexadecimal values for the character string "1234" are "0x31, 0x32, 0x33, 0x34".

XOR'ing 0x31 and 0x32 0011 0001 ^= 0011 0010 results in 0000 0011 (0x03)

XOR'ing 0x03 and 0x33 0000 0011 ^= 0011 0011 results in 0011 0000 (0x30)

XOR'ing 0x30 and 0x34 0011 0000 ^= 0011 0100 results in 0000 0100 (0x04)

Therefore, the parity is "0x04".

Note: If this parity data value is incorrect, an incorrect QR Code is generated.

Summary

Printing the character string "123456789" with a 4-dot cell size, MODEL2, standard error correction level, and automatic data input

- No linkage

ESC i Q 0x04 0x02 0x00 0x00 0x00 0x00 0x02 0x00 "123456789"

- With linkage (separated into three partitions) (The parity for character string "123456789" is "0x31".)

ESC i Q 0x04 0x02 0x01 0x01 0x03 0x31 0x02 0x00 "123"

ESC i Q 0x04 0x02 0x01 0x02 0x03 0x31 0x02 0x00 "456"

ESC i Q 0x04 0x02 0x01 0x03 0x03 0x31 0x02 0x00 "789"

② [Bar code data]: Data for the bar code

If manual input is selected for parameter 8. Data input method, the following single-byte letter must be entered in front of the bar code data.

When entering numerals: N or n

When entering alphanumeric characters: A or a

When entering kanji characters: K or k

When entering binary characters: B or b + 4-digit number string

With the four-digit number string, specify the number of binary characters to actually be entered.

For example, if 12 binary characters are to be entered, specify "B 0012 (0x30,0x30,0x31,0x32)".

Examples

1. With kanji characters:

ESC i Q [other parameters] 1 K <Enter kanji.>

2. With alphanumeric characters:

ESC i Q [other parameters] 1 A012345678abcde

3. With binary characters:

**ESC i Q [other parameters] 1 B0005##### **

The number of bar code data characters that can be entered differs depending on the model type and input method.

MODEL1: 707 alphanumeric characters, 1167 numerals, 486 bytes of binary characters, 299 kanji characters

MODEL2: 4296 alphanumeric characters, 7089 numerals, 2953 bytes of binary characters, 1817 kanji characters

Micro QR: 21 alphanumeric characters, 35 numerals, 15 bytes of binary data, 9 kanji

characters

* Note: The number of characters that can be entered (listed above) is for an error correction level at a high-density level of L 7%. If the standard level or higher is set, the number of characters that can be entered may decrease.

In addition, even if the characters are entered with a high-density level (L) specified, the number of characters that can be entered may decrease due to compression.

③ \\\: End of bar code

There must be three backslashes at the end of 2D bar codes.

| |
|---------------------------------|
| ESC i P Specify QR Code version |
|---------------------------------|

[ASCII] ESC i P n

[Decimal] 27 105 80 n

[Hexadecimal] 1B 69 50 n

[Parameters] $0 \leq n \leq 40$

[Description]

- The barcode size can be fixed.
- The default value is "0".
- The available versions differ depending on the symbol type used.

If a setting other than those listed is specified, the setting returns to its default.

The following settings are available for each symbol type.

MODEL1 (0 to 14), MODEL2 (0 to 40), Micro QR (0 to 4)

ESC i V 2D bar code (PDF417)

[ASCII] ESC i V data

[Decimal] 27 105 86 data

[Hexadecimal] 1B 69 56 data

• Format

ESC i V [parameters] [bar code data] \\\

①

②

③

① Parameters

Unlike with 1D bar codes, all parameters must be specified in order, starting from the top.

If a value other than those listed is entered for a parameter, that parameter is set to its default value.

| | | |
|---|--|--|
| 1. Cell size [1-byte decimal] 4 [1-byte decimal] 6 [1-byte decimal] 8 [1-byte decimal] 10 [1-byte decimal] 12 | Specifies the dot size per cell side. Prints 4 dots per cell side. (default value) Prints 6 dots per cell side. Prints 8 dots per cell side. Prints 10 dots per cell side. Prints 12 dots per cell side. | |
| 2. Symbol type [1-byte decimal] 0 [1-byte decimal] 1 [1-byte decimal] 2 [1-byte decimal] 3 | Standard (default value) Truncated Micro PDF417 standard Micro PDF417 CODE128 emulation | |
| 3. Data input method [1-byte decimal] 0 [1-byte decimal] 1 | Auto input (default value) Binary input | |
| 4. Error correction capacity-type [1-byte decimal] 0 [1-byte decimal] 1 | Level input (default value) Percentage input | |
| 5. Error correction capacity-value When level input is selected: [2-byte decimal] 0 to 8 When percentage input is selected: [2-byte decimal] 0 to 400 | Level input (default value of 0) Percentage input (default value of 0) | |
| 6. Symbol size in X direction [1-byte decimal] 0 [1-byte decimal] 1 to 30 | Auto setting (default value) Manual setting | |

| | | |
|---|--|--|
| * 0 and 1 to 4 with Micro PDF417 | | |
| 7. Symbol size in Y direction [1-byte decimal] 0 [1-byte decimal] 3 to 90 * 0 and 4 to 44 with MicroPDF417 | Auto setting (default value) Manual setting | |
| 8. Aspect value [2-byte decimal] 1 to 1000 | Enter the aspect value. Actually, this is between 0.01 and 10.0. However, since a decimal point cannot be entered, a value multiplied by 100 is entered. The default is "50". (The actual value is 0.5.) | |

* Note:

- The aspect value setting is ignored if the symbol size in the X direction or the symbol size in the Y direction is entered manually.
- Depending on the conditions, the bar code may not be generated or a bar code that cannot be scanned may be generated if the symbol size in the X direction or the symbol size in the Y direction is entered manually.
- When a large cell size is specified together with a high error correction capacity, printing may not be possible because the print buffer has become full.

[With symbol type Micro PDF417]

- Since the error correction capacity is automatically determined from the symbol size in the X direction, the settings for "Error correction capacity–type" and "Error correction capacity–value" are ignored.
- The aspect value setting is ignored.

The following table shows the values available for the symbol size in the Y direction according to the symbol size in the X direction. If an invalid setting is specified for the symbol size in the Y direction, the default setting is specified.

| Symbol size in X direction | Symbol size in Y direction | | | | | | | | | | | |
|----------------------------|----------------------------|----|----|----|----|----|----|----|----|----|----|----|
| AUTO | AUTO | | | | | | | | | | | |
| 1 | AUTO | 11 | 14 | 17 | 20 | 24 | 28 | | | | | |
| 2 | AUTO | 8 | 11 | 14 | 17 | 20 | 23 | 26 | | | | |
| 3 | AUTO | 6 | 8 | 10 | 12 | 15 | 20 | 26 | 32 | 38 | 44 | |
| 4 | AUTO | 4 | 6 | 8 | 10 | 12 | 15 | 20 | 26 | 32 | 38 | 44 |

② Bar code data

The number of bar code data characters that can be entered is listed below.

1850 alphanumeric characters, 2710 numerals, 1108 bytes of binary data

* Note:

The number of characters that can be entered (listed above) is for when the error correction

capacity is set to the lowest level. The number of characters that can be entered may decrease, depending on the error correction capacity value.

In addition, even if the characters are entered with the lowest density level specified, the number of characters that can be entered may decrease due to compression.

[With symbol type Micro PDF417]

Maximum of 250 alphanumeric characters, maximum of 366 numerals, maximum of 150 bytes of binary data

However, the following table shows the maximum amount of information allowed according to the symbol size in the X and Y directions.

| X | Y | Maximum amount of information allowed | | |
|---|----|---------------------------------------|----------|--------|
| | | Alphanumeric characters | Numerals | Binary |
| 1 | 11 | 6 | 8 | 3 |
| 1 | 14 | 12 | 17 | 7 |
| 1 | 17 | 18 | 26 | 10 |
| 1 | 20 | 22 | 32 | 13 |
| 1 | 24 | 30 | 44 | 18 |
| 1 | 28 | 38 | 55 | 22 |
| 2 | 8 | 14 | 20 | 8 |
| 2 | 11 | 24 | 35 | 14 |
| 2 | 14 | 36 | 52 | 21 |
| 2 | 17 | 46 | 67 | 27 |
| 2 | 20 | 56 | 82 | 33 |
| 2 | 23 | 64 | 93 | 38 |
| 2 | 26 | 72 | 105 | 43 |
| 3 | 6 | 10 | 14 | 6 |
| 3 | 8 | 18 | 26 | 10 |
| 3 | 10 | 26 | 38 | 15 |
| 3 | 12 | 34 | 49 | 20 |
| 3 | 15 | 46 | 67 | 27 |
| 3 | 20 | 66 | 96 | 39 |
| 3 | 26 | 90 | 132 | 54 |
| 3 | 32 | 114 | 167 | 68 |
| 3 | 38 | 138 | 202 | 82 |
| 3 | 44 | 162 | 237 | 97 |
| 4 | 4 | 14 | 20 | 8 |
| 4 | 6 | 22 | 32 | 13 |
| 4 | 8 | 34 | 49 | 20 |
| 4 | 10 | 46 | 67 | 27 |
| 4 | 12 | 58 | 85 | 34 |
| 4 | 15 | 76 | 111 | 45 |
| 4 | 20 | 106 | 155 | 63 |
| 4 | 26 | 142 | 208 | 85 |
| 4 | 32 | 178 | 261 | 106 |
| 4 | 38 | 214 | 313 | 128 |
| 4 | 44 | 250 | 366 | 150 |

③ \\\: End of bar code

There must be three backslashes at the end of 2D bar codes.

| |
|----------------------------------|
| ESC i D 2D bar code (DataMatrix) |
|----------------------------------|

[ASCII] ESC i D data
 [Decimal] 27 105 68 data
 [Hexadecimal] 1B 69 44 data

• Format

ESC i D [parameters] [bar code data] \\\

① ② ③

① Parameters

Unlike with 1D bar codes, all parameters must be specified in order, starting from the top.

If a value other than those listed is entered for a parameter, that parameter is set to its default value.

| | | |
|--|---|--|
| 1. Cell size [1-byte decimal] 4 [1-byte decimal] 6 [1-byte decimal] 8 [1-byte decimal] 10 [1-byte decimal] 12 | Specifies the dot size per cell side. Prints 4 dots per cell side. (default value) Prints 6 dots per cell side. Prints 8 dots per cell side. Prints 10 dots per cell side. Prints 12 dots per cell side. | |
| 2. Symbol type [1-byte decimal] 0 [1-byte decimal] 1 | ECC200 square (default value) ECC200 rectangular | |
| 3. Vertical size [1-byte decimal] 0 [1-byte decimal] 10 [1-byte decimal] 12 [1-byte decimal] 14 [1-byte decimal] 16 [1-byte decimal] 18 [1-byte decimal] 20 [1-byte decimal] 22 [1-byte decimal] 24 [1-byte decimal] 26 [1-byte decimal] 32 [1-byte decimal] 36 [1-byte decimal] 40 [1-byte decimal] 44 [1-byte decimal] 48 [1-byte decimal] 52 [1-byte decimal] 64 | ● ECC200 square Vertical no. of cells: AUTO (default value) Vertical no. of cells: 10 cells Vertical no. of cells: 12 cells Vertical no. of cells: 14 cells Vertical no. of cells: 16 cells Vertical no. of cells: 18 cells Vertical no. of cells: 20 cells Vertical no. of cells: 22 cells Vertical no. of cells: 24 cells Vertical no. of cells: 26 cells Vertical no. of cells: 32 cells Vertical no. of cells: 36 cells Vertical no. of cells: 40 cells Vertical no. of cells: 44 cells Vertical no. of cells: 48 cells Vertical no. of cells: 52 cells Vertical no. of cells: 64 cells | |

| | | | |
|--------------------|-----|--|--|
| [1-byte decimal] | 72 | Vertical no. of cells: 72 cells | |
| [1-byte decimal] | 80 | Vertical no. of cells: 80 cells | |
| [1-byte decimal] | 88 | Vertical no. of cells: 88 cells | |
| [1-byte decimal] | 96 | Vertical no. of cells: 96 cells | |
| [1-byte decimal] | 104 | Vertical no. of cells: 104 cells | |
| [1-byte decimal] | 120 | Vertical no. of cells: 120 cells | |
| [1-byte decimal] | 132 | Vertical no. of cells: 132 cells | |
| [1-byte decimal] | 144 | Vertical no. of cells: 144 cells | |
| [1-byte decimal] | 0 | <ul style="list-style-type: none"> ● ECC200 rectangular Vertical no. of cells: AUTO (default value) | |
| [1-byte decimal] | 8 | Vertical no. of cells: 8 cells | |
| [1-byte decimal] | 12 | Vertical no. of cells: 12 cells | |
| [1-byte decimal] | 16 | Vertical no. of cells: 16 cells | |
| 4. Horizontal size | | | |
| [1-byte decimal] | x | <ul style="list-style-type: none"> ● ECC200 square Horizontal no. of cells: Same value as vertical size (x) | |
| [1-byte decimal] | 0 | <ul style="list-style-type: none"> ● ECC200 rectangular ① When the vertical size is "AUTO" Horizontal no. of cells: AUTO (default value) | |
| [1-byte decimal] | 18 | ② When the vertical size is 8 cells | |
| [1-byte decimal] | 32 | Horizontal no. of cells: 18 cells | |
| [1-byte decimal] | 26 | Horizontal no. of cells: 32 cells | |
| [1-byte decimal] | 36 | ③ When the vertical size is 12 cells | |
| [1-byte decimal] | 36 | Horizontal no. of cells: 26 cells | |
| [1-byte decimal] | 48 | Horizontal no. of cells: 36 cells | |
| [1-byte decimal] | 48 | ④ When the vertical size is 16 cells | |
| [1-byte decimal] | 48 | Horizontal no. of cells: 36 cells | |
| [1-byte decimal] | 48 | Horizontal no. of cells: 48 cells | |
| 5. Spare | | | |
| [1-byte decimal]×5 | 0 | 5 bytes of dummy data (0) is sent. | |

* Note:

If the vertical size is set to a value other than those listed for ECC200 square, the "AUTO" setting is selected. If the horizontal size is set to a value different from the vertical size, the setting is changed to the same value as the horizontal size.

If the vertical or horizontal size for ECC200 rectangular is set to a value other than those listed, the "AUTO" setting is selected.

② [Bar code data]: Data for the bar code

The maximum number of bar code data characters that can be entered is listed below.

2335 alphanumeric characters, 3116 numerals, 1556 bytes of binary data

* Note:

The number of characters that can be entered (as listed above) is for the maximum vertical × horizontal cell settings (144 cells × 144 cells). The number of characters that can be entered may decrease, depending on the specified settings.

③ \\\: End of bar code

There must be three backslashes at the end of 2D bar codes.

Sample input

For data “12345” with symbol type ECC square at 40 × 40 with a 4-dot cell size, the command will be as shown below.

ESC iD 04h 00h 28h(40d) 28h 00h 00h 00h 00h 00h “12345” \\\

| |
|--------------------------------|
| ESC i M 2D bar code (MaxiCode) |
|--------------------------------|

[ASCII] ESC i M data
 [Decimal] 27 105 77 data
 [Hexadecimal] 1B 69 4D data

• Format

ESC i M [parameters] \ [bar code data] \ \ \

① ② ③ ④

① Parameters

If a value other than those listed is entered for a parameter, that parameter is set to its default value.

| | | | |
|------------------|---|--|--|
| 1. Symbol type | | | |
| [1-byte decimal] | 0 | Standard (default value) | |
| [1-byte decimal] | 1 | Full EEC | |
| [1-byte decimal] | 2 | Structured carrier message | |
| 2. Append mode | | | |
| [1-byte decimal] | 0 | Structured append (default value) | |
| [1-byte decimal] | 1 | Not appended | |

② \

Separator between parameters and bar code data

③ Bar code data

The number of bar code data characters that can be entered is listed below.

| Symbol type | Maximum amount of information allowed | |
|----------------------------|---------------------------------------|----------|
| | Alphanumeric characters | Numerals |
| Standard | 93 | 138 |
| Full EEC | 77 | 113 |
| Structured carrier message | 84 | 126 |

* Note:

The number of characters that can be entered (as listed above) is for when only the common character set (code set A in the MaxiCode specifications) is used. The number of

characters that can be entered may decrease, depending on the characters that are used.

- 2 When the symbol type is the structured carrier message, the service class, country code and postal code can be specified separately from the normal data. Specify each value, separated by a backslash and comma (\,), immediately before the normal data.

`<postal_code>\,<country_code>\,<service_class>\,<normal_bar_code_data>`

When “\,” is not used three times, the data is written as shown in the following example.

Example `<data1>\,<data2>\,<normal_bar_code_data>`

- ⇒ Postal code = data1
- ⇒ Country code = data2
- ⇒ Service class = default value

If a value other than those listed is entered for a parameter, that parameter is set to its default value.

| | |
|---|---|
| Postal code 9 or less numerals, or 6 or less alphanumeric characters | Ignored when not structured carrier message. Default value: 000000000 |
| Country code 3 or less numerals | Ignored when not structured carrier message. Default value: 000 |
| Service class 3 or less numerals | Ignored when not structured carrier message. Default value: 000 |

* Note:

If the postal code is specified as alphanumeric characters, characters other than those listed below are invalid.

A~Z “ # \$ % & ‘ () * + , - . / 0~9 :

However, lowercase letters (a~z) are converted to the valid uppercase letters (A~Z).

④ \\\: End of bar code

There must be three backslashes at the end of 2D bar codes.

ESC i F Print transferred data

[ASCII] ESC i F P n

[Decimal] 27 105 70 80 n

[Hexadecimal] 1B 69 46 50 n

[Parameters]

n: File header index
 $0 \leq n \leq 98$

[Description]

Expands transferred data as image data in the print buffer.

- Expands transferred image data from the print position.
- Ignored if there is no image data.

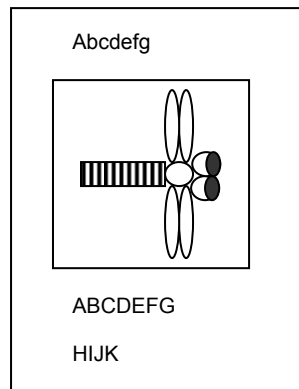
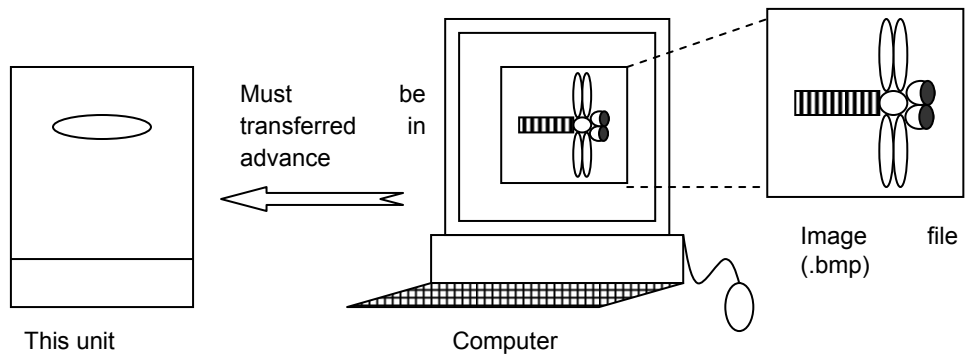

Example: Combination of text and transferred image

- As with text, if the image data does not all fit in the current line, an error occurs.

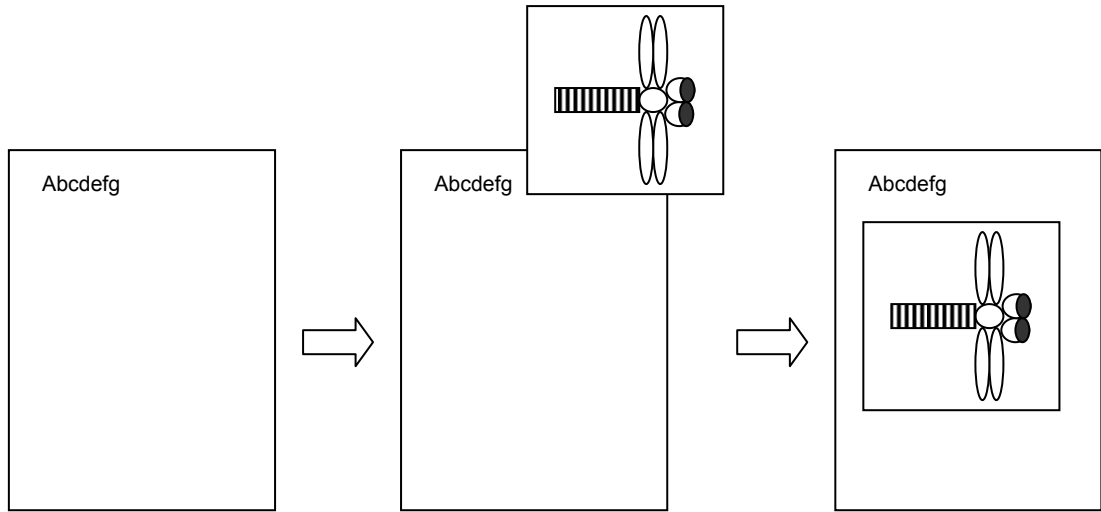

1. Enter text.

2. Enter image. transferred

3. Since the image does not fit, it is pasted in after an automatic line feed.

Example: Image at a normal size

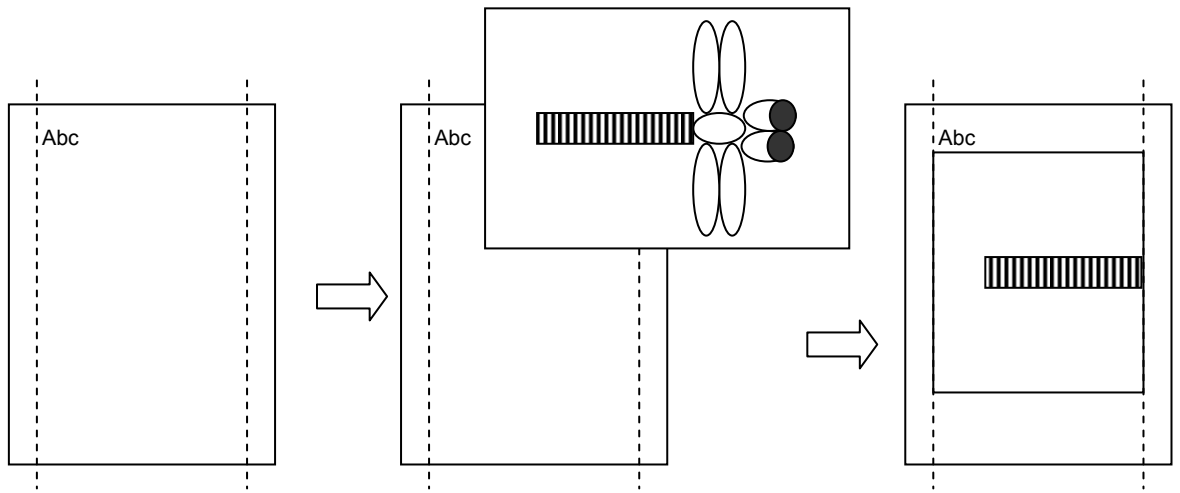

1. Enter text.

2. Enter image. transferred

3. Since the image does not fit, it is pasted in after an automatic line feed and trimmed to fit between the left and right margins.

Example: Image larger than distance between left and right margins

- If the result of pasting the transferred image exceeds the bottom margin position, the image is pasted in after a page feed. However, if the transferred image is larger than the entire area between the top and bottom margins, the entire image is ignored.

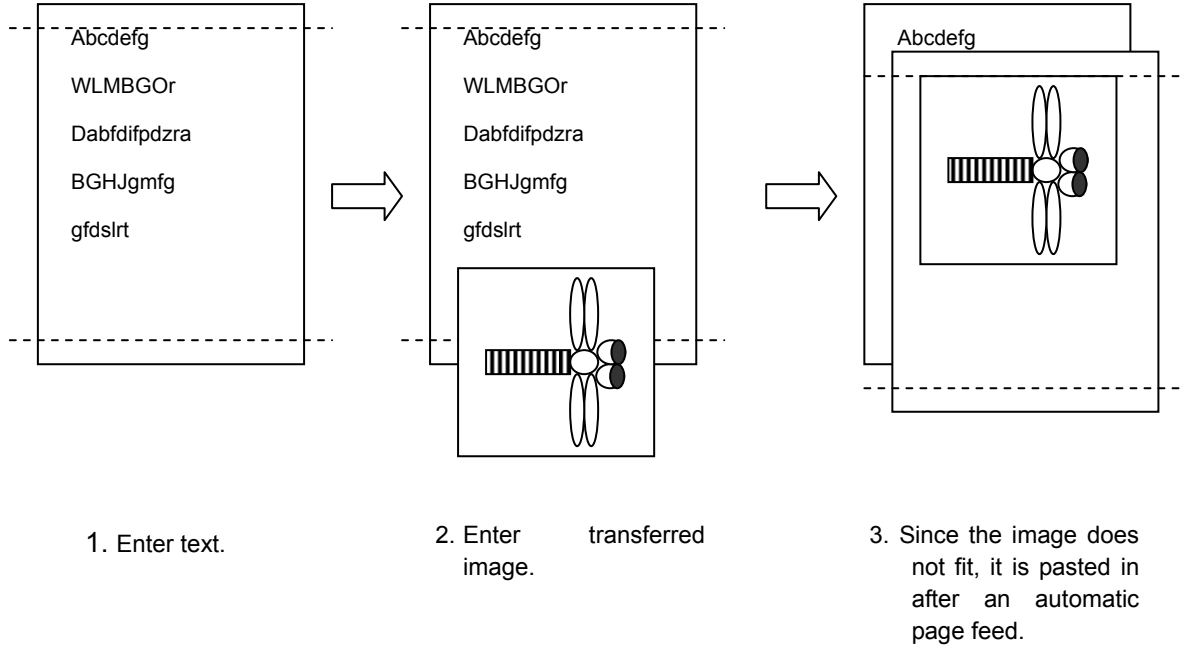

Example: Image smaller than distance between top and bottom margins

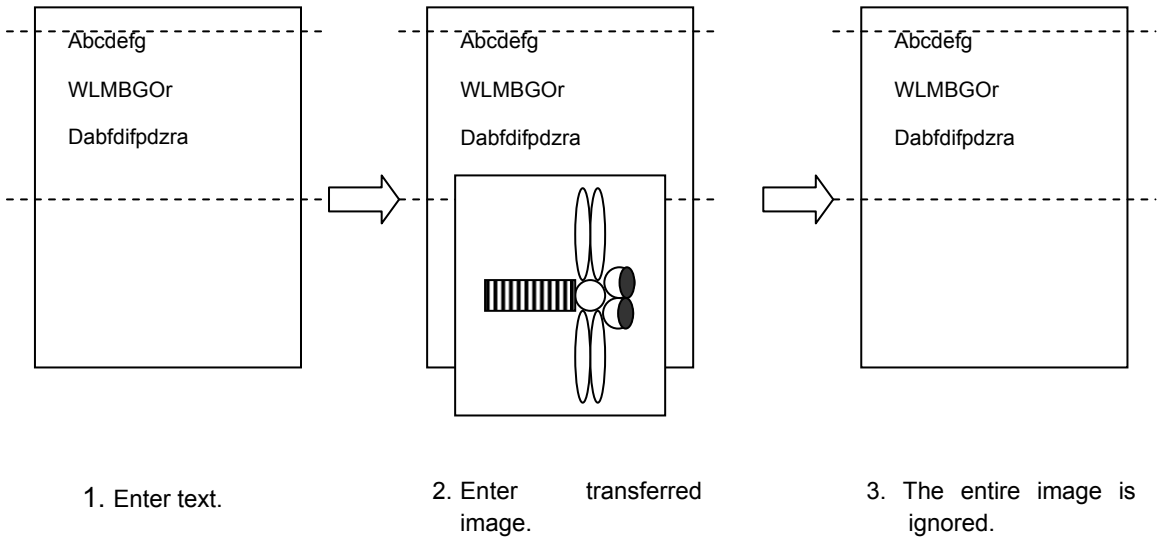

Example: Image larger than distance between top and bottom margins

- There are limits on the amount of image data that can be stored on the main unit. The storage capacity for PT-9800PCN is 6,784 KB, and the capacity for PT-9700PC is 2,048 KB. However, bitmap data is not stored as is, but is converted into the printer storage format by Transfer Manager.
- Image data larger than the media size is handled by deleting the portion of the image that does not fit within the media.

Even with the same image data, the portion that would be deleted differs depending on the media orientation at the time.

ESC i a Switch command mode

[ASCII] ESC i a n

[Decimal] 27 105 97 n

[Hexadecimal] 1B 69 61 n

[Parameters]

n: Command mode
0=ESC/P
1=Raster graphics
3=P-touch Template

[Description]

- Sets the command mode to ESC/P, PTCBP (raster graphics) or P-touch Template.
- Dynamically switches between the three modes.

ESC i S Request printer status

[ASCII] ESC i S

[Decimal] 27 105 83

[Hexadecimal] 1B 69 53

[Parameters] None

[Description]

- Requests the printer status.

The printer status consists of 32 bytes.

| Order | Offset | Size | Name | Value/Reference |
|-------|--------|------|------------------------------------|--------------------|
| 1 | 0 | 1 | Print head mark | Fixed at 80H |
| 2 | 1 | 1 | Size | Fixed at 20H |
| 3 | 2 | 1 | Brother code | Fixed at "B" (42H) |
| 4 | 3 | 1 | Series code | Fixed at "0" (30H) |
| 5 | 4 | 1 | Model code | "a" (61H) (*1) |
| | | | | "b" (61H) (*2) |
| 6 | 5 | 1 | Country code | Fixed at "0" (30H) |
| 7 | 6 | 1 | Main unit information | Fixed at 00H |
| 8 | 7 | 1 | Spare | Fixed at 00H |
| 9 | 8 | 1 | Error information 1 | See below. |
| 10 | 9 | 1 | Error information 2 | See below. |
| 11 | 10 | 1 | Media width | See below. |
| 12 | 11 | 1 | Media type | See below. |
| 13 | 12 | 1 | Number of colors | Fixed at 00H |
| 14 | 13 | 1 | Internal font information | Fixed at 00H |
| 15 | 14 | 1 | Internal Japanese font information | Fixed at 00H |
| 16 | 15 | 1 | Mode | Fixed at 00H |
| 17 | 16 | 1 | Density | Fixed at 00H |
| 18 | 17 | 1 | Media length | |
| 19 | 18 | 1 | Status type | See below. |
| 20 | 19 | 1 | Phase type | See below. |
| 21 | 20 | 1 | Phase number (upper byte) | Fixed at 00H |
| 22 | 21 | 1 | Phase number (lower byte) | Fixed at 00H |
| 23 | 22 | 1 | Notification number | Not used |
| 24 | 23 | 1 | Expansion section | Fixed at 00H |

| | | | | |
|----|----|---|-------------------|--------------|
| | | | (number of bytes) | |
| 25 | 24 | 8 | Spare | Fixed at 00H |

(*1) With PT-9800PCN

(*2) With PT-9700PC

Error information 1

| Flag | Mask | Definition |
|-------|------|----------------------|
| Bit 0 | 0x01 | "No media" error |
| Bit 1 | 0x02 | "End of media" error |
| Bit 2 | 0x04 | "Cutter jam" error |
| Bit 3 | 0x08 | Not used |
| Bit 4 | 0x10 | Not used |
| Bit 5 | 0x20 | Machine turned off |
| Bit 6 | 0x40 | Not used |
| Bit 7 | 0x80 | Not used |

Error information 2

| Flag | Mask | Definition |
|-------|------|--------------------------------|
| Bit 0 | 0x01 | "Replace media" error |
| Bit 1 | 0x02 | Not used |
| Bit 2 | 0x04 | Communication error |
| Bit 3 | 0x08 | Not used |
| Bit 4 | 0x10 | "Cover open" error |
| Bit 5 | 0x20 | "Print head overheating" error |
| Bit 6 | 0x40 | Not used |
| Bit 7 | 0x80 | System error |

Media width

| Media width | Value | Remarks |
|------------------|-------|---------|
| No tape | 00H | |
| 6-mm-wide tape | 06H | |
| 9-mm-wide tape | 09H | |
| 12-mm-wide tape | 0CH | |
| 18-mm-wide tape | 12H | |
| 24-mm-wide tape | 18H | |
| 26-mm-wide tape | 24H | |
| 3.5-mm-wide tape | 04H | |

Media type

| Media type | Value | Remarks |
|-------------------|-------|---------|
| No tape | 00H | |
| Lettering tape | 02H | |
| Laminated tape | 01H | |
| KP (thermal) tape | 03H | |

| | | |
|--------------------|-----|--|
| Non-laminated tape | 03H | |
| HG tape | 09H | |
| Incompatible tape | FFH | |

Status type

| Status type | Value |
|-------------------------|------------|
| Reply to status request | 00H |
| Printing completed | 01H |
| Error occurred | 02H |
| Not used | 03H |
| Not used | 04H |
| Notification | 05H |
| Phase change | 06H |
| Not used | 07H to EFH |
| Send advanced data | F0H |
| Not used | F1H to FFH |

Phase type

| Phase type | Value |
|--------------------|-------|
| Reception possible | 00H |
| Printing | 01H |

| |
|---------------------------------------|
| ESC i L Apply/cancel rotated printing |
|---------------------------------------|

[ASCII] ESC i L n

[Decimal] 27 105 76 n

[Hexadecimal] 1B 69 4C n

[Parameters] n=0 and 1 or 48 and 49

[Description]

- Applies rotated printing to the text.
 - If n=0 (or 30h), rotated printing is cancelled.
 - If n=1 (or 31h), rotated printing is applied.

| |
|-----------------------------|
| ESC i C Specify cut setting |
|-----------------------------|

[ASCII] ESC i C n

[Decimal] 27 105 67 n

[Hexadecimal] 1B 69 43 n

[Parameters] $0 \leq n \leq 255$

[Description]

- Specifies full cut, half cut, chain printing or special tape.
- The n parameter (1 byte) specifies all settings in bit units, as shown below.

| | | | | | | | |
|---|---|---|---|---|---|---|---|
| 7 | 6 | 5 | 4 | 3 | 2 | 1 | 0 |
|---|---|---|---|---|---|---|---|

- 0: Full cut
- 1: Half cut
- 2: Chain printing
- 3: Special tape
- 4: Not used
- 5: Not used
- 6: Not used
- 7: Not used

- If bit 0 of parameter n is "1", full cut is specified. If it is "0", full cut is cancelled.
- If bit 1 of parameter n is "1", half cut is specified. If it is "0", half cut is cancelled.
- If bit 2 of parameter n is "1", chain printing is applied. If it is "0", chain printing is cancelled.
- If bit 3 of parameter n is "1", special tape is specified. If it is "0", special tape is cancelled.

When special tape is specified, full cut, half cut and chain printing are not available (same as being cancelled).

| | |
|-----------|-------------------|
| ESC i U B | Specify baud rate |
|-----------|-------------------|

[ASCII] ESC i U B n

[Decimal] 27 105 85 66 n

[Hexadecimal] 1B 69 55 42 n

[Parameters] $0 \leq n \leq 12$

[Description]

- As an RS-232C communication setting, the baud rate is specified as listed below.

If n=0 115200 bps

If n=1 600 bps

If n=2 1200 bps

If n=3 2400 bps

If n=4 4800 bps

If n=5 9600 bps

If n=6 14400 bps

If n=7 19200 bps

If n=8 28800 bps

If n=9 31250 bps

If n=10 38400 bps

If n=11 57600 bps

If n=12 115200 bps

- The setting is applied the next time that the machine is turned on.

| | |
|-----------|--------------------|
| ESC i U b | Specify bit length |
|-----------|--------------------|

[ASCII] ESC i U b n

[Decimal] 27 105 85 98 n

[Hexadecimal] 1B 69 55 62 n

[Parameters] $0 \leq n \leq 1$

[Description]

- As an RS-232C communication setting, the bit length is specified as listed below.

If n=1 7 bits

If n=1 8 bits

- The setting is applied the next time that the machine is turned on.

| | |
|-----------|------------------------|
| ESC i U P | Specify parity setting |
|-----------|------------------------|

[ASCII] ESC i U P n

[Decimal] 27 105 85 80 n

[Hexadecimal] 1B 69 55 50 n

[Parameters] $0 \leq n \leq 2$

[Description]

- As an RS-232C communication setting, the parity is specified as listed below.

If n=0 None

If n=1 ODD

If n=2 EVEN

- The setting is applied the next time that the machine is turned on.

| | |
|-----------|----------------------|
| ESC i U C | Specify busy control |
|-----------|----------------------|

[ASCII] ESC i U C n

[Decimal] 27 105 85 67 n

[Hexadecimal] 1B 69 55 43 n

[Parameters] $0 \leq n \leq 1$

[Description]

- As an RS-232C communication setting, the busy control is specified as listed below.

If n=0 Hardware (DTR)

If n=1 X-ON/X-OFF

- The setting is applied the next time that the machine is turned on.

Character code

Appendix CG list (for overseas)

Standard character code table for ESC/P codes

| | 0 | 1 | 2 | 3 | 4 | 5 | 6 | 7 | 8 | 9 | A | B | C | D | E | F |
|---|---|---|----|---|---|---|---|-----|---|-----|---|-----|---|---|---|---|
| 0 | | | SP | 0 | @ | P | ` | p | Ç | É | á | ☼ | L | ■ | α | ■ |
| 1 | | | ! | 1 | A | Q | a | q | ü | æ | í | ☼ | ⊥ | ■ | β | ± |
| 2 | | | ” | 2 | B | R | b | r | é | Æ | ó | ☼ | ⊥ | ■ | ■ | ■ |
| 3 | | | # | 3 | C | S | c | s | â | ô | ú | | † | ■ | ■ | ¾ |
| 4 | | | \$ | 4 | D | T | d | t | ä | ö | ñ | † | — | ■ | ■ | ■ |
| 5 | | | % | 5 | E | U | e | u | à | ò | Ñ | ■ | † | ■ | ■ | § |
| 6 | | | & | 6 | F | V | f | v | å | û | ª | ■ | ■ | ■ | μ | ÷ |
| 7 | | | , | 7 | G | W | g | w | ç | ù | º | ■ | ■ | ■ | ■ | ■ |
| 8 | | | (| 8 | H | X | h | x | ê | ÿ | ¿ | © | ℒ | ■ | ■ | ° |
| 9 | | |) | 9 | I | Y | i | y | ë | Ö | ® | ¶ | ¶ | ⌋ | ■ | . |
| A | | | * | : | J | Z | j | z | è | Ü | € | ¶ | ¶ | ⌋ | Ω | ■ |
| B | | | + | ; | K | [| k | { | ï | ç | ½ | ¶ | ¶ | ✓ | δ | ■ |
| C | | | , | < | L | \ | l | ! | î | £ | ¼ | ¶ | ¶ | ☑ | ■ | ³ |
| D | | | - | = | M |] | m | } | ì | ¥ | ¡ | TEL | = | ■ | ø | ² |
| E | | | . | > | N | ^ | n | ~ | Ä | Pts | « | FAX | ¶ | ■ | ■ | ■ |
| F | | | / | ? | O | _ | o | DEL | Å | f | » | ¶ | ■ | □ | ■ | ■ |

“■” indicates that a space is printed.

“■” indicates that the character will change if the international character set is switched.

Eastern European character code table (Windows 1250)

| | 0 | 1 | 2 | 3 | 4 | 5 | 6 | 7 | 8 | 9 | A | B | C | D | E | F |
|---|---|---|----|---|---|---|---|-----|-----|---|---|---|---|---|---|---|
| 0 | | | SP | 0 | @ | P | ` | p | € | ť | ■ | ° | Ř | Đ | ř | ď |
| 1 | | | ! | 1 | A | Q | a | q | À | ‘ | ˇ | ± | Á | Ň | á | ň |
| 2 | | | " | 2 | B | R | b | r | , | ’ | ˇ | ˘ | Â | Ň | â | ň |
| 3 | | | # | 3 | C | S | c | s | L | “ | Ł | ł | Ǻ | Ó | ǻ | ó |
| 4 | | | \$ | 4 | D | T | d | t | „ | ” | ⊠ | ’ | Ä | Ô | ä | ô |
| 5 | | | % | 5 | E | U | e | u | ... | • | Ą | μ | Ł | Ŏ | í | ó |
| 6 | | | & | 6 | F | V | f | v | † | – | | ¶ | Ć | Ö | ć | ö |
| 7 | | | ’ | 7 | G | W | g | w | ‡ | — | § | · | Ç | × | ç | ÷ |
| 8 | | | (| 8 | H | X | h | x | Ĳ | ■ | ˙ | ˘ | Č | Ř | č | ř |
| 9 | | |) | 9 | I | Y | i | y | ‰ | ™ | © | ą | É | Ů | é | ů |
| A | | | * | : | J | Z | j | z | Š | š | Ş | ş | Ę | Ú | ę | ú |
| B | | | + | ; | K | [| k | { | < | > | « | » | Ë | Ů | ë | ů |
| C | | | , | < | L | \ | l | ! | Ś | ś | ¬ | Ł | Ě | Ü | ě | ü |
| D | | | – | = | M |] | m | } | Ť | ť | – | ” | Í | Ý | í | ý |
| E | | | . | > | N | ^ | n | ~ | Ž | ž | ® | ł | Î | Ť | î | ț |
| F | | | / | ? | O | _ | o | DEL | Ž | ž | Ż | ż | Ď | ß | ď | · |

“■” indicates that a space is printed.

“■” indicates that the character will change if the international character set is switched.

Western European character code table (Windows 1252)

| | 0 | 1 | 2 | 3 | 4 | 5 | 6 | 7 | 8 | 9 | A | B | C | D | E | F |
|---|---|---|----|---|---|---|---|-----|-----|---|---|---|---|---|---|---|
| 0 | | | SP | 0 | @ | P | ` | p | € | ■ | ■ | ° | À | Đ | à | ò |
| 1 | | | ! | 1 | A | Q | a | q | ~ | ' | i | ± | Á | Ñ | á | ñ |
| 2 | | | ” | 2 | B | R | b | r | , | ' | ¢ | ² | Â | Ò | â | ò |
| 3 | | | # | 3 | C | S | c | s | f | “ | £ | ³ | Ã | Ó | ã | ó |
| 4 | | | \$ | 4 | D | T | d | t | „ | ” | ¤ | ' | Ä | Ô | ä | ô |
| 5 | | | % | 5 | E | U | e | u | ... | • | ¥ | μ | Å | Õ | å | õ |
| 6 | | | & | 6 | F | V | f | v | † | — | | ¶ | Æ | Ö | æ | ö |
| 7 | | | ' | 7 | G | W | g | w | ‡ | — | § | · | Ç | × | ç | ÷ |
| 8 | | | (| 8 | H | X | h | x | ^ | ~ | ¨ | ¸ | È | Ø | è | ø |
| 9 | | |) | 9 | I | Y | i | y | ‰ | ™ | © | ¹ | É | Ù | é | ù |
| A | | | * | : | J | Z | j | z | Š | š | ª | º | Ê | Ú | ê | ú |
| B | | | + | ; | K | [| k | { | < | > | « | » | Ë | Û | ë | û |
| C | | | , | < | L | \ | l | ! | Œ | œ | ¬ | ¼ | Ì | Ü | ì | ü |
| D | | | - | = | M |] | m | } | ■ | ■ | - | ½ | Í | Ý | í | ý |
| E | | | . | > | N | ^ | n | ~ | Ž | ž | ® | ¾ | Î | Þ | î | þ |
| F | | | / | ? | O | _ | o | DEL | ■ | ÿ | — | ¿ | Ï | Ɔ | ï | ÿ |

“■” indicates that a space is printed.

“■” indicates that the character will change if the international character set is switched.

International character set

Compatible characters in each language when the international character set is switched

| n | | 23 | 24 | 40 | 5B | 5C | 5D | 5E | 60 | 7B | 7C | 7D | 7E |
|----|---------------|----|----|----|----|----|----|----|----|----|----|----|----|
| 0 | United States | # | \$ | @ | [| \ |] | ^ | ` | { | | } | ~ |
| 1 | France | # | \$ | à | ° | ç | § | ^ | ` | é | ù | è | ¨ |
| 2 | Germany | # | \$ | § | Ä | Ö | Ü | ^ | ` | ä | ö | ü | ß |
| 3 | Britain | £ | \$ | @ | [| \ |] | ^ | ` | { | | } | ~ |
| 4 | Denmark I | # | \$ | @ | Æ | Ø | Å | ^ | ` | æ | ø | å | ~ |
| 5 | Sweden | # | ¤ | É | Ä | Ö | Å | Ü | é | ä | ö | å | ü |
| 6 | Italy | # | \$ | @ | ° | \ | é | ^ | ù | à | ò | è | ì |
| 7 | Spain I | Pt | \$ | @ | ı | Ñ | ı | ^ | ` | ¨ | ñ | } | ~ |
| 8 | Japan | # | \$ | @ | [| ¥ |] | ^ | ` | { | | } | ~ |
| 9 | Norway | # | ¤ | É | Æ | Ø | Å | Ü | é | æ | ø | å | ü |
| 10 | Denmark II | # | \$ | É | Æ | Ø | Å | Ü | é | æ | ø | å | ü |
| 11 | Spain II | # | \$ | á | ı | Ñ | ı | é | ` | í | ñ | ó | ú |
| 12 | Latin America | # | \$ | á | ı | Ñ | ı | é | ü | í | ñ | ó | ú |
| 13 | Korea | # | \$ | @ | [| ₩ |] | ^ | ` | { | | } | ~ |
| 64 | Legal | # | \$ | § | ° | ' | " | ¶ | ` | © | ® | † | ™ |

BROTHER PT-9800PCN/9700PC ESC/P specifications

| | | | |
|----------|-------------------------|--|---|
| Printing | Print mode | | Raster (PCBP mode) ESC/P mode P-touch Template mode |
| | Maximum printing length | | 1 m |
| | Resolution (dpi) | | 360dpi × 360dpi |
| | Text | Fonts | <Overseas> Bitmap fonts: Helsinki, Letter Gothic |
| | | Size (dots) | <Overseas> Bitmap fonts: 21 × 21, 28 × 28, 44 × 44, 56 × 56, 88 × 88, 120 × 120 (dots) |
| | | Character style | None , Bold, Italics |
| | | Underline | Off , On |
| | | Character width | Half-width, Normal , Double-width |
| | | Horizontal alignment | Left , Center, Right, Justify |
| | | Rotate | Vertical , Horizontal |
| Bar code | Protocols | CODE39 , ITF (I-2/5), EAN-13, EAN-8, UPC-A, UPC-E, CODABAR, CODE128, GS1-128 (UCC/EAN-128), QR Code (Model 1, Model 2, micro QR), PDF417 (Standard, Truncate, Micro PDF417), DataMatrix (ECC200 Square, ECC200 Rectangular), MaxiCode, RSS-14 (Standard, Truncated, Stacked, Stacked Omni), RSS-Limited, RSS Expanded (Standard, Stacked) | |
| | Width | Large, Medium, Small | |
| Transfer | RS | Baud rate (bps) | 115.2K, 57.6K, 38.4K, 31.25K, 28.8K, 19.2K, 14.4K, 9600 , 4800, 2400, 1200, 600 |
| | | Busy | DTR , Xon/Xoff |
| | | Bit length | 8 , 7 |
| | | Parity | None , ODD, EVEN |
| | | Stop bit | 1 bit |

Settings that appear in bold and underlined are the default settings.