



P-touch

E850TKW
Quick Setup Guide

English

Thank you for purchasing the P-touch model E850TKW. Your new E850TKW is an intuitive, easy to operate and feature-rich labeller that produces professionally looking, high-quality labels. This manual contains basic procedures for using the P-touch. Read the whole guide before using your product and keep it for later reference. The available options and supplies may vary depending on the country.

Available Manuals

Visit the Brother support website at support.brother.com and click **Manuals** on your model page to download the latest manuals.

■ **Product Safety Guide**

This guide provides safety information; read it before you use the P-touch.

■ **Quick Setup Guide (this guide)**

This guide provides basic information about using the P-touch along with detailed troubleshooting tips.

■ **User's Guide**

This guide provides additional information about the P-touch settings and operations, troubleshooting tips, and maintenance instructions. This guide is on the included CD-ROM.

Unpacking Your P-touch

Before using your P-touch, check that the package contains the following:

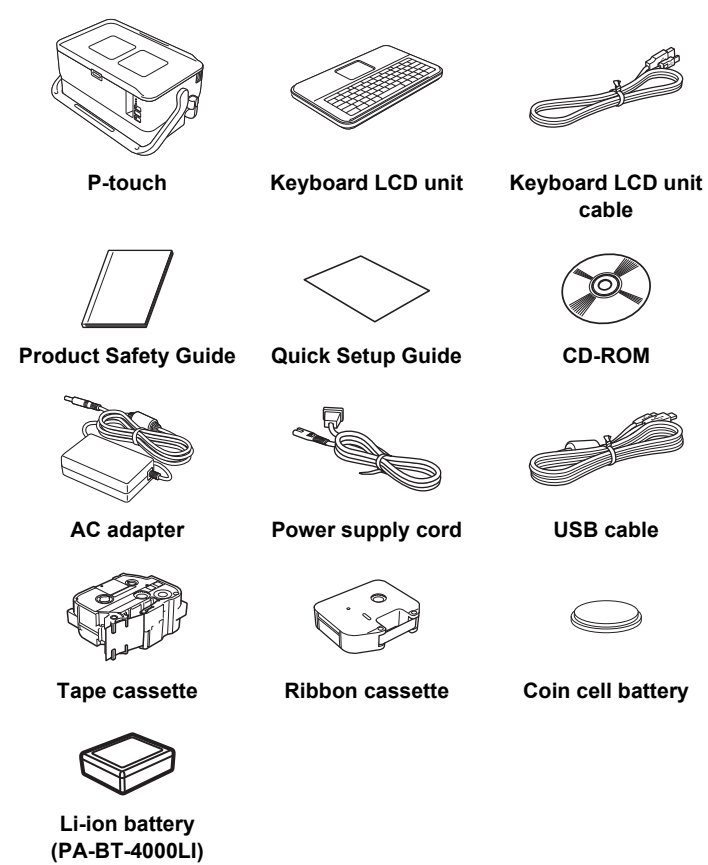

The components included in the box may differ depending on your country.

General Description

Front

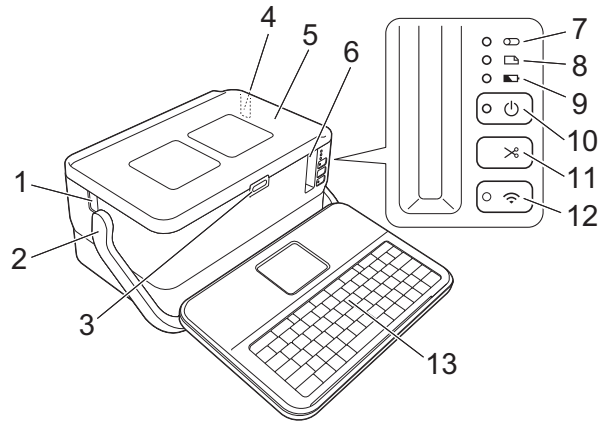

Back

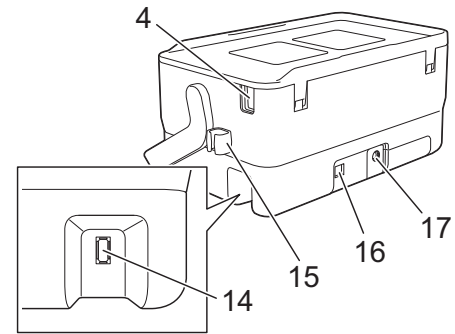

- | | |
|-----------------------|--|
| 1 Tube exit slot | 11 (Feed and Cut) button |
| 2 Handle | 12 (Wi-Fi) button |
| 3 Cover open button | 13 Keyboard LCD unit |
| 4 Tube insert slot | 14 Keyboard LCD unit interface socket |
| 5 Top cover | 15 Cable holder (holder for the keyboard LCD unit cable) |
| 6 Tape exit slot | 16 USB port |
| 7 (Tube) indicator | 17 AC adapter socket |
| 8 (Label) indicator | |
| 9 (Battery) indicator | |
| 10 (Power) button | |

Inside

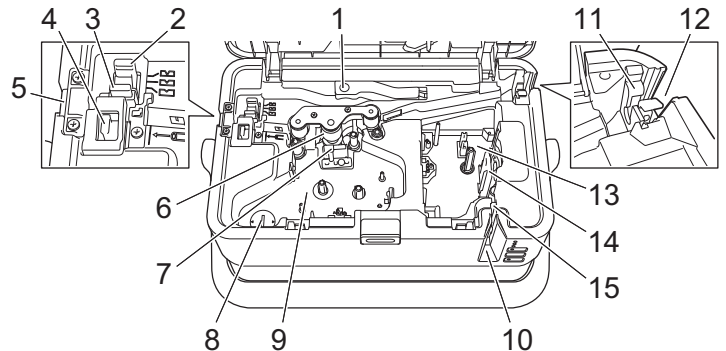

- | | |
|----------------------------|--|
| 1 Tube release lever | 9 Ribbon cassette compartment (for tube) |
| 2 Tube half-cut adjuster | 10 Tape exit slot |
| 3 Tube cutter board | 11 Tube cleaner |
| 4 Tube cutter | 12 Tube insert slot |
| 5 Tube exit slot | 13 Tape cassette compartment |
| 6 Platen roller | 14 Print head (for tape) |
| 7 Print head (for tube) | 15 Tape cutter unit |
| 8 Coin cell battery holder | |

IMPORTANT

Before using the P-touch, make sure you remove the protective material according to the following procedure.

- 1 Press the cover open button to open the top cover.
- 2 Pull the tape to remove the tape together with the protective material.

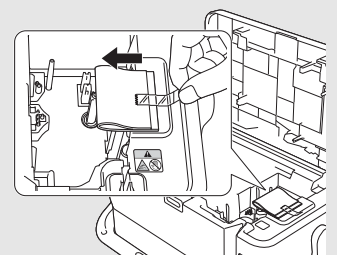

Attaching the Keyboard LCD Unit

- Slide the cover on the bottom of the keyboard LCD unit to remove it, and then connect the keyboard LCD unit cable. Install the cover.

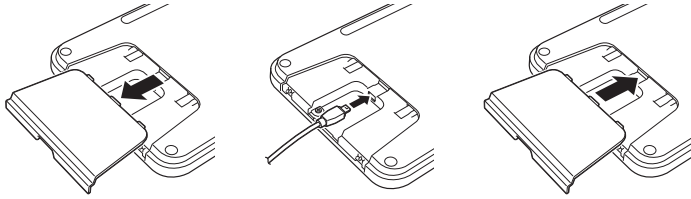

- Connect the USB cable on the keyboard LCD unit to the socket on the side of the P-touch.

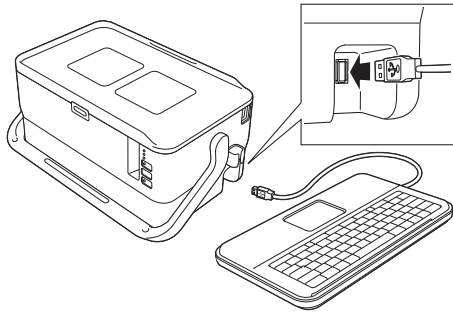

NOTE

- When you turn the P-touch on, the keyboard LCD unit is also turned on.
- The keyboard LCD unit can be installed on the P-touch by sliding it on the top cover. When storing the keyboard LCD unit, turn it upside down and install it to the top cover to prevent it from becoming dusty or dirty.
- You can place the excess cable in the cable holder.

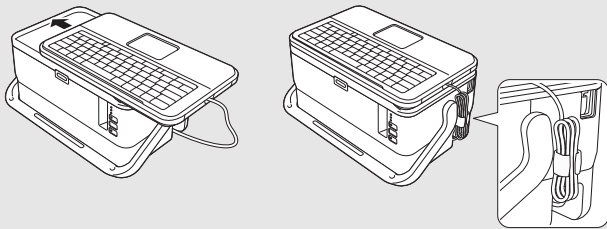

Installing the Coin Cell Battery

A coin cell battery is used as a back-up power supply to maintain the settings for the internal clock of the keyboard LCD unit. The battery will be consumed even if the P-touch is not used for a long period of time.

IMPORTANT

- Dispose of the battery at an appropriate collection point, not in the general waste stream. In addition, be sure to observe all applicable federal, state, and local regulations.
- When storing or discarding the battery, wrap it (for example with cellophane tape) to prevent it from short-circuiting. (Battery insulation example)

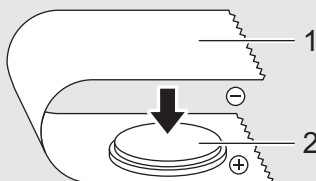

- Cellophane tape
- Coin cell battery

- We recommend replacing the battery every two years.

- Make sure the P-touch is turned off.
- Press the cover open button to open the top cover.
- Using a coin or similar object, slowly turn the coin cell battery cover in the direction of the arrow on the battery cover until it stops, and then remove the coin cell battery cover.

IMPORTANT

If the coin cell battery cover is forcibly turned past the stop position, it may become damaged.

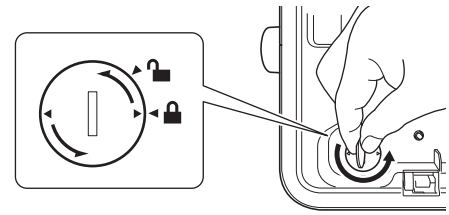

- Install the battery.

IMPORTANT

Be sure to insert the new battery with the + and - sides facing the correct direction.

- Return the coin cell battery cover to its original position. To install the coin cell battery cover, use a coin or similar object to slowly turn the coin cell battery cover in the opposite direction of the arrow on the battery cover until it stops.

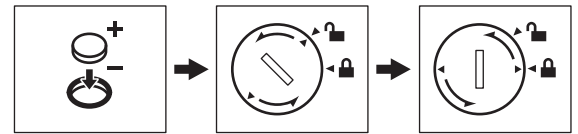

For more information, see the *User's Guide*.

Connecting the Power Supply

AC Adapter

Use the AD9100ESA (AC adapter) for this P-touch. Connect the AC adapter directly to the P-touch.

- Insert the plug on the AC adapter cord into the AC adapter socket marked DC IN 24 V on the P-touch.
- Insert the plug on the power supply cord into the AC adapter.

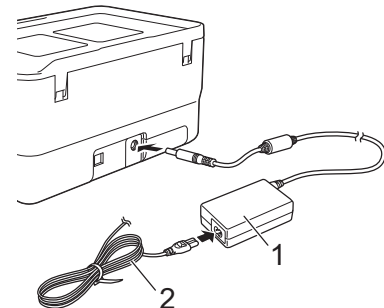

- AC adapter
- Power supply cord

- Insert the power supply plug into a standard electrical socket.

IMPORTANT

- Turn the P-touch off before disconnecting the AC adapter.
- Do not pull or bend the AC adapter cord and power supply cord.
- After the power supply plug is inserted into the electrical socket, it may take a few seconds until the ⏻ (Power) button is enabled.

NOTE

To safeguard and backup the P-touch memory, when the power supply is unplugged it is recommended to leave the rechargeable Li-ion batteries (PA-BT-4000LI), installed in the P-touch.

Using the Rechargeable Li-ion Battery

■ Installing the Rechargeable Li-ion Battery

- Press and hold the ⏻ (Power) button to turn the P-touch off.
- Open the battery cover on the bottom of the P-touch.

3. Insert the battery into the battery compartment.
4. Close the battery cover.

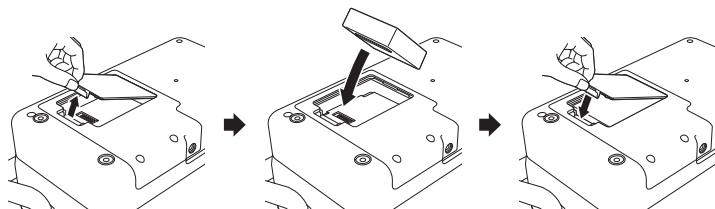

■ Removing the Rechargeable Li-ion Battery

Press and hold the  (Power) button to turn the P-touch off. Remove the battery cover and the battery, and then reattach the battery cover.

■ Charging the Rechargeable Li-ion Battery

NOTE

- Before use, fully charge the battery.
- Up to three hours may be needed to fully charge the battery.

1. Make sure that the battery is installed in the P-touch.
2. Use the AC adapter and power supply cord to connect the P-touch to an electrical socket.

Press the  (Power) button to turn the P-touch on if it is not on already.

The  (Battery) indicator lights in orange during charging, and it goes off when the battery is fully charged.

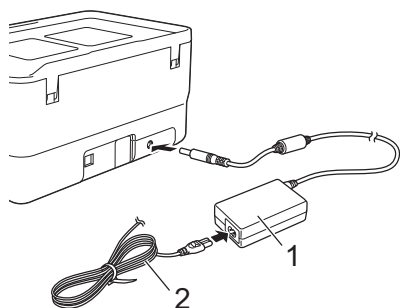

- 1 AC adapter
- 2 Power supply cord



NOTE

Although the charging stops if the P-touch is used to print, feed, or perform another operation, the charging will start again automatically after the operation is finished if the charging is not completed.

■ Stopping Rechargeable Li-ion Battery Charging

To stop the battery charging, disconnect the AC adapter.

Notes on Using the Rechargeable Li-ion Battery

- Before use, fully charge the battery. Do not use it before it is fully charged.
- The battery charging must take place in environments between 0°C and 40°C, otherwise the battery will not charge, and the  (Battery) indicator will remain lit. If the charging stops because the environment temperature is too low or too high, place the P-touch with a temperature between 0°C and 40°C and try charging again.
- If the P-touch is used to print, feed, or perform another operation when both the battery is installed and the AC adapter is connected, the  (Battery) indicator may turn off and charging may stop even if the battery is not fully charged.

Rechargeable Li-ion Battery Characteristics

To ensure the highest performance and longest life from the battery:

- Do not use or store the battery in a location exposed to extreme high or low temperatures as it may discharge more quickly. This may happen when using a rechargeable Li-ion battery with a high charge (90% charged or more) in a location exposed to high temperatures.
- Remove the battery when storing the P-touch for long periods of time.
- Store a battery with less than a 50% charge in a cool dry place out of direct sunlight.
- Recharge the battery every six months if it is stored for long periods of time.
- If you touch a part of the P-touch while the Li-ion battery is charging, that part of the P-touch may feel warm. This is normal, and the P-touch may be used safely. However, if the P-touch becomes extremely hot, discontinue use.

Inserting a Tube

1. Open the top cover.

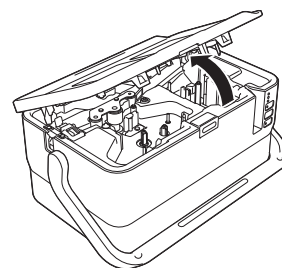

2. Pull the tube release lever up.

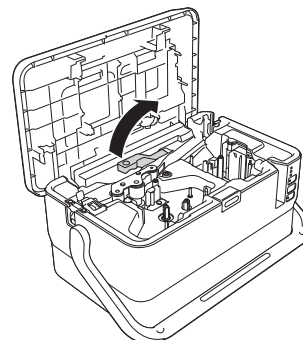

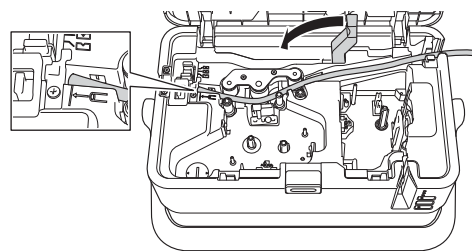

3. Pass the tube as shown in the illustration so that the end of the tube reaches the "┆┆" mark on the P-touch, and then push the tube release lever down.



4. Close the top cover.

NOTE

- Do not use tube which is dirty, bent, flattened, has a rough surface or uneven tube thickness, or is defective in any other way.
- When using the P-touch, position it so direct sunlight does not enter the P-touch through the tube exit slot.
- You can use the tube half-cut adjuster to adjust the depth of half cuts to one of three settings.
- If the tube is jammed or not cut completely, use the  (Feed and Cut) button to manually cut the tube completely. Press and hold the button for 2 to 10 seconds until the  (Power) indicator changes from being lit in green to flashing in green, and then release it. The tube will be cut when the button is released.

Inserting a Ribbon Cassette

1. Open the top cover.
2. Insert the ribbon cassette into the ribbon cassette compartment, and then push down evenly until the tape cassette is installed correctly.

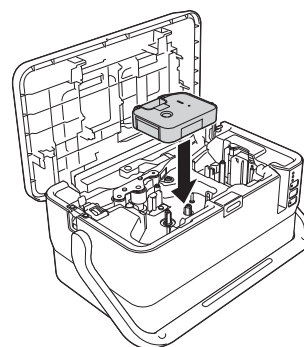

3. Close the top cover.

Inserting a Tape Cassette

The TZe tape, FLe label, and HSe tube cassettes can be used in your P-touch.

IMPORTANT

If the new tape cassette has a cardboard stopper, be sure to remove the stopper before inserting the cassette.

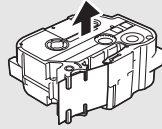

1. Check that the end of the tape is not bent and that it passes through the tape guide. If it does not, pass it through the tape guide as shown in the illustration.

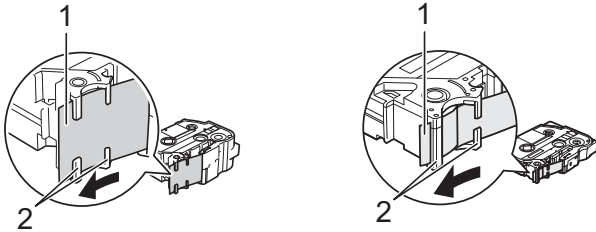

- 1 End of tape
- 2 Tape guides (The actual shape may be different depending on the tape width.)

2. Press the cover open button to open the top cover.
3. Insert the tape cassette into the tape cassette compartment with the end of the tape facing the P-touch tape exit slot, then push down evenly until the tape cassette is installed correctly.

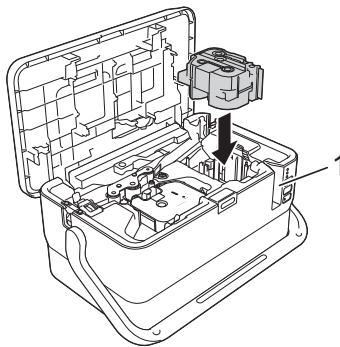

1 Tape exit slot

IMPORTANT

- When inserting the tape cassette, make sure that the tape and ink ribbon do not catch on the print head.
- Make sure that there is no slack in the tape, and then carefully insert the tape cassette. If there is slack in the tape, the tape will catch on the protrusion (2) when the cassette is inserted and become bent or wrinkled, causing the tape to jam.
- To fix the slack in the tape, refer to the illustration in step 1 and pull the tape outside of the tape guide.
- When removing the tape cassette, make sure that the tape does not catch on the protrusion (2).

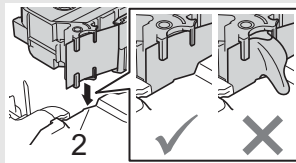

4. Close the top cover.

IMPORTANT

Store tape cassettes in a cool dark location, away from direct sunlight and high temperature, high humidity, or dusty locations. After opening the sealed package, use the tape cassette as quickly as possible.

Turning Power On/Off

On: Press the (Power) button to turn the P-touch on. The (Power) indicator lights in green.

NOTE

When the P-touch is turned on for the first time, the language selection screen appears. Select the language you want using the or key. The language setting can also be changed later. (See *Setting Language*.)

Off: Press and hold the (Power) button again to turn the P-touch off. The (Power) indicator may light in orange until the power is off.

IMPORTANT

When turning the P-touch off, do NOT remove the battery or disconnect the AC adapter until the (Power) indicator turns off.

Keyboard LCD Unit Description

Key Names and Functions

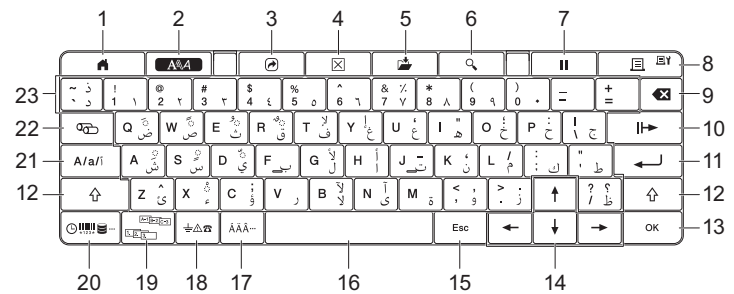

- 1 **Home**
Returns to the Home screen to select a menu.
- 2 **Format**
Sets characters and attributes.
- 3 **Program**
Opens a registered program.
- 4 **Clear**
Clears all text entered, or all text and current settings.
- 5 **Save**
Saves the created data in the file memory.
- 6 **Preview**
For tubes, displays the entered character string so that you can check it before printing.
For labels, displays an image of the label that will be printed in the set layout.
- 7 **Pause**
Interrupts the printing.
- 8 **Print/Print Option**
 - Prints the current data onto the tape or tube.
 - Prints multiple copies or changes the print settings when used in combination with the **Shift** key.
- 9 **Backspace**
Deletes the character to the left of the cursor.
- 10 **Next**
Creates the next page.
- 11 **Enter**
Adds a new line when entering text.
Selects the displayed option.
- 12 **Shift**
Enters upper-case letters or symbols when used in combination with the letter keys or number keys.
- 13 **OK**
Selects the displayed option.
- 14 **Cursor (↑ ↓ ← →)**
Moves the cursor in the direction of the arrow.
- 15 **Esc**
Cancels the current command and returns the display to the data entry screen or the previous step.
- 16 **Space**
 - Inserts a blank space.
 - Returns a setting to the default value.
- 17 **Accent**
Selects and enters an accented character.
- 18 **Symbol**
Selects and enters a symbol from a list of available symbols.
- 19 **Serialize**
Sets serialized numbers.
- 20 **Insert**
Inserts a time stamp, barcode, database, or transferred symbol.
- 21 **Input mode**
Selects input mode.
- 22 **Copies**
For tubes, sets the number of copies.
For labels, no function.
- 23 **Letter**
Enters letters or numbers.

LCD

■ Home Screen

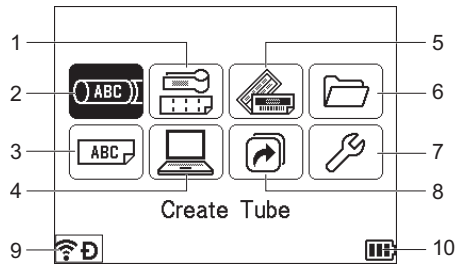

- 1 **Cable Label**
Specifies the label type from the following seven types: Faceplate/Cable Wrap/Cable Flag/Patch Panel/Punch-Down Block/Die-cut Flag/Inverted Label.
- 2 **Create Tube**
Displays the tube creation screen.
- 3 **Create Label**
Displays the label creating screen.
- 4 **Transferred Templates**
Retrieves data that was transferred from a computer.
- 5 **Auto Format**
Specifies the label format from the preset templates and layouts.
- 6 **File**
Retrieves data that is saved in the file memory.
- 7 **Settings**
Specifies various settings for the P-touch.
- 8 **Register Programmable Function**
Registers, deletes, and renames programs.
- 9 **Wireless Connection**
The left icon indicates the status of the Wi-Fi® connection and the right icon indicates the status of the Wireless Direct connection.

	Connected in Wi-Fi mode
	Disconnected in Wi-Fi mode
	Wireless direct mode ON
	Establishing connection by Setup Wizard
	Wireless connection OFF

- 10 **Battery Level**
Indicates the remaining battery level. It appears only when using the Li-ion battery.

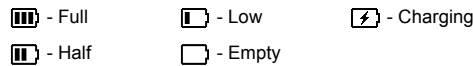

■ Tube Creation Screen

NOTE

When you open the tube creating screen for the first time after purchasing the P-touch, the screen for setting the diameter and length of the installed tube appears.

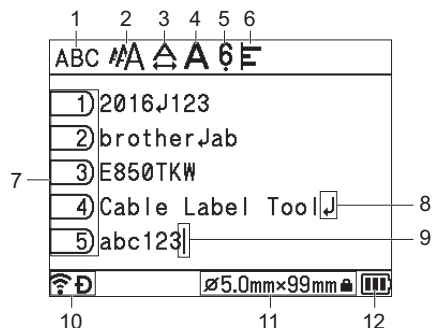

- 1 **Input Mode**
Indicates the current input mode.
- 2-6 **Style Guidance**
Indicates the current character size (2), character width (3), style (4), 6/9 accent (5), and alignment (6) settings.
- 7 **Page Number**
Indicates the page number.
- 8 **Enter/Return Symbol**
Indicates the end of a line of text.
- 9 **Cursor**
Indicates the current data input position. Characters are entered to the left of the cursor.

- 10 **Wireless Connection**
Indicates the current status of the wireless connection. See *Wireless Connection* in the explanation of the Home screen.
- 11 **Tube Size**
Indicates the tube size as follows according to the entered text: Tube diameter × Tube length. If the tube length has been specified, also appears on the right side of the tube size.
- 12 **Battery Level**
Indicates the remaining battery level. It appears only when using the Li-ion battery. See *Battery Level* in the explanation of the Home screen.

■ Label Creation Screen

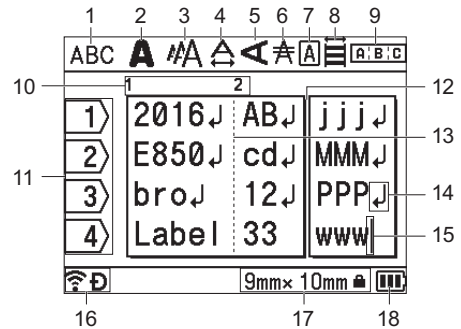

- 1 **Input Mode**
Indicates the current input mode.
- 2-8 **Style Guidance**
Indicates the current font (2), character size (3), character width (4), character style (5), line (6), frame (7), and alignment (8) settings. The alignment guidance may not be displayed depending on the selected label type.
- 9 **Layout Guidance**
Indicates the orientation, layout, separator, reverse, and repeated text settings. The displayed items vary according to the selected label type.
- 10 **Block Number**
Indicates the block number.
- 11 **Line Number**
Indicates the line number within the label layout.
- 12 **Page Separator Line**
Indicates the end of one page and the beginning of the next page.
- 13 **Block Separator Line**
Indicates the end of a block.
- 14 **Enter/Return Symbol**
Indicates the end of a line of text.
- 15 **Cursor**
Indicates the current data input position. Characters are entered to the left of the cursor.
- 16 **Wireless Connection**
Indicates the current status of the wireless connection. See *Wireless Connection* in the Home Screen section.
- 17 **Tape Size**
Indicates the tape size as follows for the text entered: Tape width × Label length. If the label length has been specified, also appears on the right side of the tape size.
- 18 **Battery Level**
Indicates the remaining battery level. It appears only when using the Li-ion battery. See *Battery Level* in the Home Screen section.

Feeding Tape

IMPORTANT

- Be sure to feed tape to remove any slack in the tape and ink ribbon after inserting the tape cassette.
- **Do not pull the label when the P-touch is ejecting it from the tape exit slot.** Doing so will cause the ink ribbon to be discharged with the tape. The tape may no longer be functional after the ink ribbon discharges.
- Do not block the tape exit slot during printing or when feeding tape. Doing so will cause the tape to jam.

Feed and Cut

The Feed and Cut function feeds approximately 22.3 mm of blank tape, and then cuts the tape.

1. Press the (Feed and Cut) button.
[Feed & Cut?] appears on the LCD.

- Select [Feed & Cut] using the ↑ or ↓ key, and then press the **OK** or **Enter** key. The message [Feeding Tape... Please Wait] appears while the tape is fed, and then the tape is cut.

NOTE

To exit or cancel this function press the **Esc** key.

Feed Only

This function will eject the tape approximately 22.3 mm, resulting in a blank label sticking out of the tape cassette. This action is recommended when using Fabric tapes, which should be cut using scissors.

- Press the  (Feed and Cut) button.
[Feed & Cut?] appears on the LCD.
- Select [Feed Only] using the ↑ or ↓ key, and then press the **OK** or **Enter** key. The message [Feeding Tape... Please Wait] appears while the tape is fed.

NOTE

To exit or cancel this function press the **Esc** key.

Setting Language

- Select [Settings] in the Home screen using the ↑, ↓, ← or → key, and then press the **OK** or **Enter** key.
- Select [ Language] using the ↑ or ↓ key, and then press the **OK** or **Enter** key.
- Select a language for menu commands and messages shown on the LCD using the ↑ or ↓ key.
The following languages are available:[English], [العربية].
- Press the **OK** or **Enter** key.

NOTE



To return to the previous step, press the **Esc** key.

Setting Input Character

When you input text, to enter Arabic characters, lowercase English characters, or uppercase English characters, press the input mode key and switch to the corresponding input mode.



















LED Indicators

The indicators light and flash to indicate the P-touch labeller's status. The symbols used in this section explain the meaning of the different indicator colours and patterns:















-  = Indicator is lit
 -  = Indicator is flashing
 -  = Indicator can be off, lit or flashing in any colour
 - (Off) = Indicator is off
- G = Green
O = Orange
R = Red

Example:  = Indicator is flashing in green















■ Tube, Label, Power indicator

 (Tube)	 (Label)	 (Power)	Condition
(Off)	(Off)		Power is turning off Top cover open
(Off)	(Off)	 (1 time in 1 second)	Transferring data
			Now cooling
(Off)			System error 1 System error 2 System error 3
(Off)			Reset mode (when the mode is starting)
(Off)			Reset mode (when the button is pressed 2/4/6 times)
 (1 time in 2 seconds)	(Off)		In pause mode (Tube)
(Off)	(Off)	 (2 times in 1.8 seconds)	In cutting mode (Tube)
(Off)			In pause mode (Label)

■ Battery indicator

 (Battery)	 (Power)	Condition
(Off)		Rechargeable battery power: full
		Charging
 (1 time in 4 seconds)		Rechargeable battery power: half
 (2 times in 4 seconds)		Rechargeable battery power: low
		Rechargeable battery error
		Rechargeable battery power: empty
		Adapter connection/disconnection error

■ Wi-Fi indicator

 (Wi-Fi)	 (Power)	Condition
		No available WPS access point was found
		WPS access point connection error
 (2 times in 1.8 seconds)		Incorrect security settings
 (2 times in 1.8 seconds)		WPS access point search error
		Wi-Fi on, not connected
		Wi-Fi on, connected
(Off)		Wi-Fi off

Product Specifications

Model Name	E850TKW
Size	
Dimensions	approx. 338 mm (W) × 188 mm (D) × 173 mm (H) (including keyboard LCD unit)
Weight	approx. 4.6 kg (including keyboard LCD unit, excluding Li-ion Battery)
Printing	
Method	Thermal Transfer
Compatible tubes ¹	<ul style="list-style-type: none"> • Inner diameter: Φ2.5–Φ6.5 mm • Thickness: 0.5 mm • Material: PVC
Cassette	<ul style="list-style-type: none"> • Brother TZe tape cassette (3.5 mm, 6 mm, 9 mm, 12 mm, 18 mm, 24 mm, 36 mm widths) • Brother FLe label cassette (21 mm × 45 mm) • Brother HSe tube cassette (5.8 mm, 8.8 mm, 11.7 mm, 17.7 mm, 23.6 mm widths) • Brother TR ribbon cassette (12 mm width)
Interface	
USB	Version 2.0 Full Speed
Wi-Fi	<ul style="list-style-type: none"> • Wireless Direct: IEEE802.11n • Ad-Hoc mode: IEEE802.11b • Infrastructure mode: IEEE802.11b/g/n • WPS 2.0
Environment	
Operating temperature/humidity	<ul style="list-style-type: none"> • TZe engine When running: between 10°C and 35°C / between 20% and 80% max. wet bulb temperature: 27°C • Tube engine When running: between 15°C and 35°C / between 20% and 80% max. wet bulb temperature: 27°C

¹ You may not be able to obtain high-quality printing results depending on the type of tube you are using. Before using a tube, print a test to check the results.

This product adopts the font of ARPHIC TECHNOLOGY CO.,LTD.

Brother support website

Please visit our support website at support.brother.com.

You can find following information:

- Software downloads
- Manuals/Documents
- Frequently Asked Questions (Troubleshooting, Useful tips on using printer)
- Consumable information
- Latest OS compatibility information

The contents of this website are subject to change without notice.

Create a Tube or Label



You can use the P-touch keyboard LCD unit to create and print data for tubes and labels. Because the P-touch is portable, it can be used as a single unit without worrying about the strength of the wireless signal or connecting to other devices, and can be used anytime and anywhere.

1. GETTING STARTED	Reference
Preparing the P-touch.	<i>Quick Setup Guide</i> (this guide)
2. CREATING	Reference
Use the tube creation screen to create print data for tubes and use the label creation screen to create print data for labels. To open the tube creation screen, select [Create Tube] in the Home screen. To open the label creation screen, select [Create Label] in the Home screen.	
Creating print data.	<p><i>User's Guide</i></p> <p>Note:</p> <ul style="list-style-type: none"> • In addition to entering text, the P-touch has a large range of formatting options. • The items that can be printed on labels and tubes are different. For example, barcodes cannot be inserted into tubes.
2. PRINTING	Reference
Setting cut options.	<i>User's Guide</i>
Printing the tube or label.	<p>Note:</p> <p>Before printing, you can check the layout of your tube or label using the preview function.</p>



Create a Label using a Mobile Device

Your P-touch can be used as a stand-alone labeller, or it can be connected to a mobile device and used with the Brother applications to create labels and print directly from your mobile device.

To print labels from your mobile device, install the Brother applications to your mobile device, and then connect your P-touch to your mobile device. The following Brother applications can be downloaded free-of-charge from the App Store or Google Play™:

Application	Feature	Mobile Device	Connection
 Mobile Cable Label Tool	Print labels for cables and patch panels using templates on a smartphone, tablet or other mobile device directly to your P-touch. >>> For Label only	Apple iPhone/iPad/iPod touch or Android™ device	Wireless Direct / Wi-Fi
 Brother iPrint&Label	Create and print labels using templates on a smartphone, tablet or other mobile device directly to your P-touch. >>> For Label only		
 Mobile Transfer Express	Allows you to use a mobile device to download databases and label data, which was created on a computer using P-touch Editor and saved to a cloud service, and send them to your P-touch. >>> For Label only		

■ Connecting Your P-touch to a Mobile Device



1. Turn the P-touch on, and then press and hold the  (Wi-Fi) button until the  (Wi-Fi) indicator is lit in green.
2. Turn on the Wi-Fi function on your Apple iPhone/iPad/iPod touch or Android™ device.
3. Start the application on your Apple iPhone/iPad/iPod touch or Android™ device, and then select your P-touch as the printer in the application.
Select "PT-E850TKW" or "DIRECT-*****_PT-E850TKW".
***** is the last five digits of the product serial number.
You can find the serial number label on the bottom of the P-touch.
When the password (network key) is required, type "00000000".

Create a Tube or Label using a Computer

NOTE

- You must install P-touch software and the printer driver to use your P-touch with your computer.
For installation, use the installer CD-ROM packaged together with the P-touch.
- We recommend getting the SSID (network name) and password (network key) of the wireless network in advance.

Your P-touch can be connected to a computer and used with the Cable Label Tool or P-touch Editor software to create more complex tubes or labels. For more information, see the *User's Guide*.

Available Applications	Features	Computer	Connection
 Cable Label Tool	Create and print labels for cables, patch panels, faceplates, electrical equipment and more.	Windows	Wi-Fi / USB
 P-touch Editor	Design and print custom labels with built in drawing tools, text using different fonts and styles, imported graphic images and barcodes.		

Cable Label Type

You can create various types of cable labels by selecting "Cable Label" in the Home screen using the P-touch keyboard LCD unit or connecting your P-touch to a computer and using Cable Label Tool. The available cable label types are as follows:

NOTE

- This section explains the various label types using the displayed screens when you use the keyboard LCD unit.
- For more information about cable label type, see the *User's Guide*.

Faceplate

Labels of this type can be used to identify various faceplates. Blocks of text are evenly spaced on a single label.

One block

1A-B01

Two blocks

1A-B01 1A-B02

Cable Wrap

Labels of this type can be wrapped around a cable or wire.

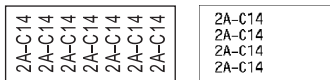

NOTE

When using Flexible ID Tape:

- We recommend using Flexible ID Tape for "Cable Wrap" labels.
- When wrapping labels around cylindrical objects, the diameter (1) of the object should be at least 3 mm.
- The overlapping (2) ends of the label should be at least 5 mm.
- Labels made with Flexible ID Tape are not designed for use as electrical insulation.

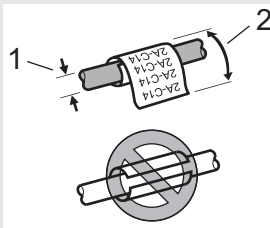

NOTE

When using Self-Laminating Tape:

- We recommend using Self-Laminating Tape for "Cable Wrap" labels.
- The text is horizontally printed.
- Labels made with Self-Laminating Tape are not designed for use as electrical insulation.

Cable Flag

Labels of this type can be wrapped around a cable or wire, and both ends of the label stick together to form a flag. The text on flag labels is printed on both ends of the label, leaving a blank space in the middle that wraps around the cable.

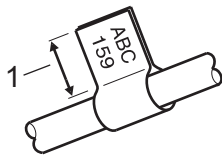

1 Flag length at least 15 mm

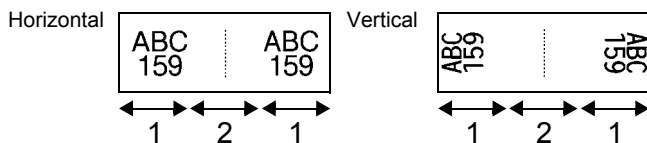

- 1 Flag length
- 2 Cable circumference

NOTE

- You can enter up to two barcodes when **AA AA** is selected in flag layout (only when using the P-touch keyboard).
- We recommend using Flexible ID Tape for "Cable Flag" labels.

Patch Panel

Labels of this type can be used to identify various types of panels.

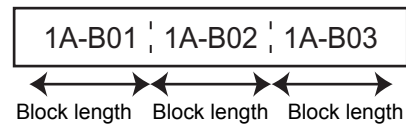
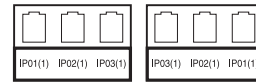

Punch-Down Block

Labels of this type can be used to identify a type of electrical connection often used in telephony. You can enter up to eight lines for each block on a single label.

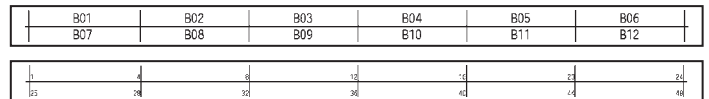

Die-cut Flag

Labels of this type can be printed on special die-cut flag labels to create flag labels for cables and wires. Use the FLe label cassettes for this type.

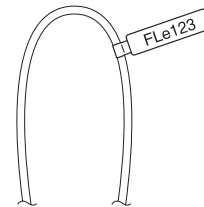

Inverted Label (only when using the P-touch keyboard)

Labels of this type can be printed with the text and background colours reversed without changing the tape cassette. In addition, you can create labels with a small label height by setting "Orientation" to "Vertical".



NOTE

- The font and font style are set to Helsinki and bold respectively and cannot be changed.
- The following types of tape cannot be used:
 - 3.5 mm tape
 - Stencil tape
 - Heat Shrink Tube
 - Die-cut flag label

PVC Tube

Tubes of this type can be used to identify or insulate cables, or to protect them from heat.

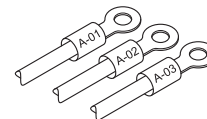

NOTE

When using the P-touch keyboard to create a tube, select "Create Tube" in the Home screen.

Heat Shrink Tube (only when connecting to a computer)

Tubes of this type shrink by heat to fit a cable. Use the HSe tube cassettes for this type.

